

# UpRight

---

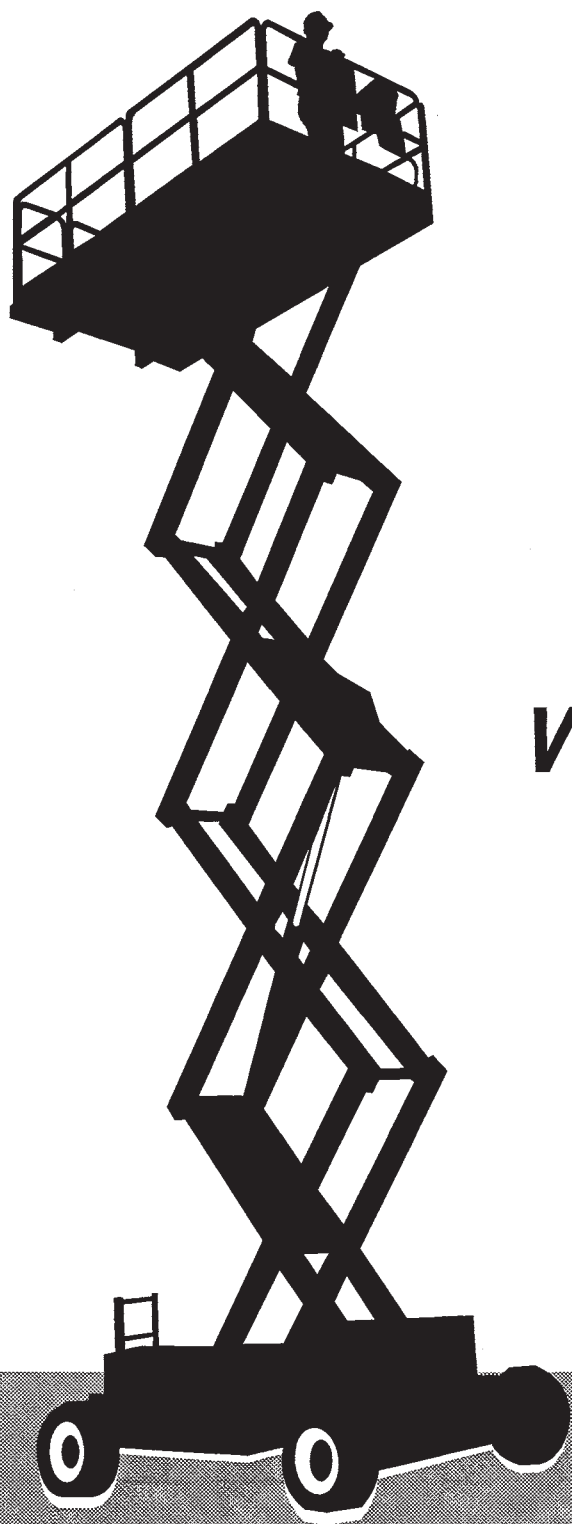

# LX50

**WORK PLATFORMS**

**Service &**

**Parts Manual**

P/N 067904-003

# SERVICE & PARTS MANUAL

## LX 50

### Gasoline, Dual Fuel, and Diesel Models

Serial Numbers 1001 - 2746

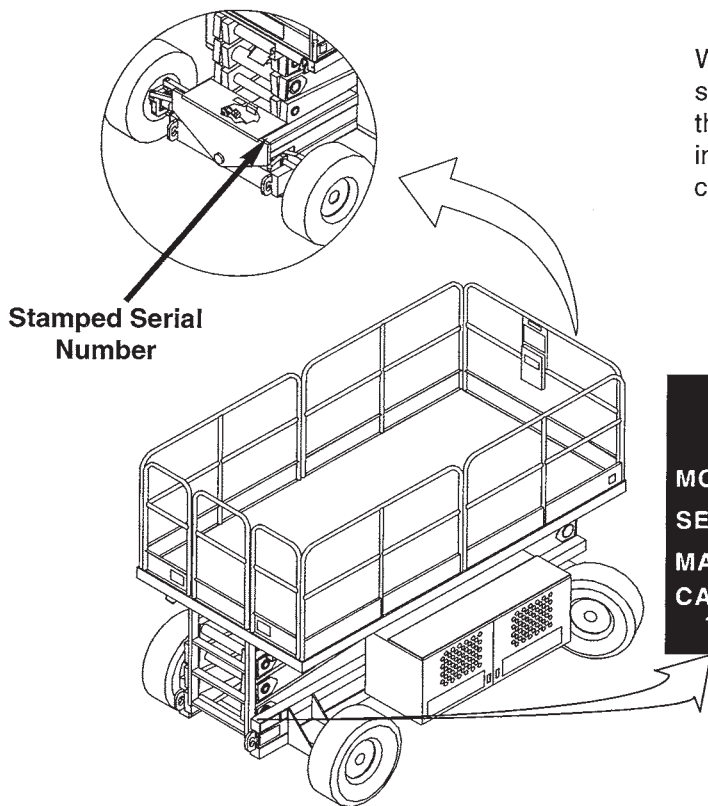

When contacting UpRight for service or parts information, be sure to include the MODEL and SERIAL NUMBERS from the equipment nameplate. Should the nameplate be missing, the SERIAL NUMBER is also stamped on top of the chassis above the front axle pivot.

#### UpRight, Inc.

1775 PARK ST.

SELMA, CA 93662 USA

MODEL NO.  MAX. PLATFORM HEIGHT

SERIAL NO.  BATTERY VOLTAGE

MAX. DISTRIBUTED LOAD

CAUTION: CONSULT OPERATOR'S MANUAL BEFORE USE.

THIS PLATFORM IS NOT ELECTRICALLY INSULATED

P/N 61205-000-00

#### UpRight, Inc.

801 South Pine Street  
Madera, California 93637

TEL: 559-662-3900

FAX: 559-673-6184

PARTS: 1-888-UR-PARTS

PARTS FAX: 1-800-669-9884

# UpRight

Call Toll Free in U.S.A.

1-800-926-LIFT

#### UpRight

Unit S1, Park West Industrial Park  
Friel Avenue  
Nangor Road  
Dublin 12, Ireland

TEL: +353 1 620 9300

FAX: +353 1 620 9301

# Forward

## Introduction

### HOW TO USE THIS MANUAL

This manual is divided into 7 sections. The right hand pages of each section is marked with a black tab that lines up with one of the thumb index tabs on the right side of this page. You can quickly find each section without looking through the table of contents which follows this page. The section number printed at the top corner of each page can also be used as a quick reference guide.

### SPECIAL INFORMATION



#### DANGER



Indicates the hazard or unsafe practice *will* result in severe injury or death.



#### WARNING



Indicates the hazard or unsafe practice *could* result in severe injury or death.



#### CAUTION



Indicates the hazard or unsafe practice could result in *minor* injury or property damage.

NOTES: Give helpful information.

### WORKSHOP PROCEDURES

**CAUTION:** Detailed descriptions of standard workshop procedures, safety principles and service operations are not included. Please note that this manual does contain warnings and cautions against some specific service methods which could cause personal injury, or could damage a machine or make it unsafe. Please understand that these warnings cannot cover all conceivable ways in which service, whether or not recommended by UpRight, Inc., might be done, or of the possible hazardous consequences of each conceivable way, nor could UpRight Inc. investigate all such ways. Anyone using service procedures or tools, whether or not recommended by UpRight Inc., must satisfy themselves thoroughly that neither personal safety nor machine safety will be jeopardized.

All information contained in this manual is based on the latest product information available at the time of printing. We reserve the right to make changes at any time without notice. No part of this publication may be reproduced, stored in retrieval system, or transmitted, in any form by any means, electronic, mechanical, photocopying, recording, or otherwise, without the prior written permission of the publisher. This includes text, figures and tables.

## Introduction & Specifications

# 1.0

General description and machine specifications.

## Machine Preparation

# 2.0

Information on preparation for use & shipment, forklifting, transporting and storage.

## Operation

# 3.0

Operating instructions and safety rules.

## Maintenance

# 4.0

Preventative maintenance and service information.

## Troubleshooting

# 5.0

Causes and solutions to typical problems.

## Schematics

# 6.0

Schematics and valve block diagram with description and location of components.

## Illustrated Parts Breakdown

# 7.0

Complete parts lists with illustrations.

# Forward

## NOTES



## Table of Contents

Section No.	Page No.	Section No.	Page No.
<b>1.0 Introduction &amp; Specifications</b>		<b>4.0 Maintenance</b>	
1.0 Introduction .....	1-1	4.0 Introduction .....	4-1
Purpose .....	1-1	Special Tools .....	4-1
Scope .....	1-1	4.1 Preventative Maintenance .....	4-1
1.1 General Description .....	1-1	Preventative Maintenance Table Key .....	4-2
Platform .....	1-1	Preventative Maintenance Report .....	4-2
Controller .....	1-1	4.2 Blocking Elevating Assembly .....	4-3
Elevating Assembly .....	1-1	Installation .....	4-3
Power Module .....	1-1	Removal .....	4-3
Control Module .....	1-1	4.3 Battery Maintenance .....	4-4
Chassis .....	1-1	Battery Inspection and Cleaning .....	4-4
Purpose of Equipment .....	1-1	4.4 Lubrication .....	4-4
Special Limitations .....	1-1	Grease Fittings .....	4-4
1.2 Specifications .....	1-2	Steering Linkage .....	4-4
<b>2.0 Machine Preparation</b>		Torque Hubs .....	4-4
2.1 Preparation for Use .....	2-1	Hydraulic Oil and Filter .....	4-5
2.2 Transporting Work Platform .....	2-1	Fluid Level .....	4-5
By Crane .....	2-1	Oil and Filter Replacement .....	4-5
By Truck .....	2-1	4.5 Setting Hydraulic Pressures .....	4-6
2.4 Preparation for Shipment .....	2-2	Pump Set-Up .....	4-6
2.5 Storage .....	2-2	Lift Relief Valve .....	4-6
Preservation .....	2-2	Counterbalance Valves .....	4-7
Battery .....	2-2	Steering Relief Valves .....	4-7
<b>3.0 Operation</b>		Bidirectional Relief Valves .....	4-7
3.0 Safety Rules .....	3-1	4.6 Switch Adjustments .....	4-8
Raising the Platform .....	3-2	Proportional Control Adjustment .....	4-8
Lowering the Platform .....	3-2	Procedure .....	4-8
Leveling the platform		Platform Down Limit Switches .....	4-8
(Outrigger equipped machines only) .....	3-2	Axle Center Switch .....	4-9
Design Features .....	3-3	Tilt Sensor .....	4-9
Safety Rules and Precautions .....	3-3	4.7 Hydraulic Manifold .....	4-10
Controls and Indicators .....	3-4	Removal .....	4-10
Controller/Platform .....	3-4	Disassembly .....	4-10
Chassis .....	3-4	Cleaning and Inspection .....	4-10
Pre-Operation Inspection .....	3-6	Assembly .....	4-10
System Function Inspection .....	3-6	Installation .....	4-10
Operation .....	3-8	4.8 Hydraulic Pump .....	4-12
Travel With Platform Lowered .....	3-8	Removal .....	4-12
Steering .....	3-8	Installation .....	4-12
Leveling the Platform (Outrigger equipped		4.9 Hydraulic Brakes, Drive Motors, And Hubs .....	4-12
machines only) .....	3-8	Rear Axle .....	4-12
To retract outriggers .....	3-8	Removal .....	4-12
Raising and Lowering the Platform .....	3-8	Installation .....	4-13
Travel with Work Platform Elevated .....	3-9	Seal Replacement, Brake .....	4-13
Emergency Lowering .....	3-9	Seal Replacement, Rear Motor .....	4-14
Switching Fuels		Front Axle 4WD .....	4-16
(Dual Fuel Only) .....	3-9	Removal .....	4-16
After Use Each Day .....	3-9	Installation .....	4-16
Parking Brake Release .....	3-9	Seal Replacement, Front Motor .....	4-18
Fold Down Guardrails .....	3-10	4.10 Axle Cylinder (4WD Only) .....	4-20
Fold Down Procedure .....	3-10	Removal .....	4-20
Erection Procedure .....	3-10	Seal Replacement .....	4-20
		Installation .....	4-20
		4.11 Steering Cylinder .....	4-22
		Removal .....	4-22
		Seal replacement .....	4-22
		Installation .....	4-22

## Table of Contents (cont.)

Section No.	Page No.	Section No.	Page No.
4.12 Lift Cylinder .....	4-24	Scissor Linkage Assembly, LX 50	
Removal .....	4-24	67517-000 .....	7-36
Seal Replacement .....	4-24	Scissor Linkage Assembly, LX 50 Dual Deck	
Installation .....	4-25	67424-000 .....	7-38
4-13 Outrigger Cylinder .....	4-26	Control Module Assembly, Two Wheel Drive Gas	
Removal .....	4-26	67521-000 .....	7-40
Seal Replacement .....	4-26	Control Module Assembly, Two Wheel Drive Diesel	
Installation .....	4-26	67521-001 .....	7-42
4.14 Torque Specifications .....	4-30	Control Module Assembly, Four Wheel Drive Gas	
Fasteners .....	4-30	67521-002 .....	7-44
Hydraulic Components .....	4-30	Control Module Assembly, Four Wheel Drive Diesel	
		67521-003 .....	7-46
<b>5.0 Troubleshooting</b>		Control Module Assembly, Two Wheel Drive Gas	
5.0 Introduction .....	5-1	Dual Deck 67521-004 .....	7-48
General Procedure .....	5-1	Control Module Assembly, Two Wheel Drive Diesel	
5.1 Troubleshooting Guide .....	5-1	Dual Deck 67521-005 .....	7-50
<b>6.0 Schematics</b>		Control Module Assembly, Four Wheel Drive Gas	
6.0 Introduction .....	6-1	Dual Deck 67521-006 .....	7-52
6.1 Electrical Schematics .....	6-2	Control Module Assembly, Four Wheel Drive Diesel	
6.2 Hydraulic Schematics .....	6-20	Dual Deck 67521-007 .....	7-54
6.3 Component Location .....	6-28	Power Module Assembly, LX50, Gas	
6.4 Lower Control Box .....	6-28	67522-001 .....	7-56
6.5 Platform Control Box .....	6-36	Power Module Assembly, LX50, Diesel	
		67522-002 .....	7-58
<b>7.0 Illustrated Parts Breakdown</b>		Engine Assembly, LX50, Kubota Gas	
7.0 Introduction .....	7-1	67523-001 .....	7-60
7.1 Index .....	7-1	Engine Assembly, LX50, Kubota Diesel	
7.2 Illustrated Parts Breakdown .....	7-2	67523-002(Up to S/N 2218) .....	7-64
Final Assembly, LX50, Two Wheel Drive Gas		Engine Assembly, LX50, Kubota Diesel	
67546-001 .....	7-4	67523-002(S/N 2218 to Current) .....	7-68
Final Assembly, LX50, Two Wheel Drive Diesel		Valve Block Assembly, LX50, Two Wheel Drive	
67547-001 .....	7-4	67524-000 .....	7-72
Final Assembly, LX50, Four Wheel Drive Gas		Valve Block Assembly, LX50, Four Wheel Drive	
67548-000 .....	7-10	67524-001 .....	7-73
Final Assembly, LX50, Four Wheel Drive Gas		Control Box Assembly, LX50, Gas	
67549-000 .....	7-10	67527-000 .....	7-74
Final Assembly, Dual Deck, Two Wheel Drive Gas		Control Box Assembly, LX50, Diesel	
67408-000 .....	7-16	67527-001 .....	7-78
Final Assembly, Dual Deck, Two Wheel Drive Diesel		Control Box Assembly, Two Wheel Drive, Gas	
67409-000 .....	7-16	Dual Deck 67527-002 .....	7-82
Final Assembly, Dual Deck, Four Wheel Drive Gas		Control Box Assembly, Four Wheel Drive, Diesel	
67410-000 .....	7-22	Dual Deck 67527-003 .....	7-86
Final Assembly, Dual Deck, Four Wheel Drive Diesel		Panel Assembly, LX50, Four Wheel Drive Gas	
67411-000 .....	7-22	67529-000 .....	7-90
Basic Assembly, LX50, Two Wheel Drive		Panel Assembly, LX50, Four Wheel Drive Diesel	
67508-000 .....	7-28	67529-001 .....	7-90
Basic Assembly, LX50, Four Wheel Drive		Panel Assembly, LX50, Two Wheel Drive Diesel	
67509-000 .....	7-29	67529-002 .....	7-90
Basic Assembly, Dual Deck Two Wheel Drive		Panel Assembly, LX50, Two Wheel Drive Gas	
67419-000 .....	7-30	67529-003 .....	7-90
Basic Assembly, Dual Deck Four Wheel Drive		Controller Assembly, LX50	
67420-000 .....	7-31	67528-000 .....	7-92
Chassis Assembly, LX50, Two Wheel Drive			
67518-001 .....	7-32		
Chassis Assembly, LX50, Four Wheel Drive			
67519-001 .....	7-34		

## Table of Contents (cont.)

Section No.	Page No.
Guardrail Assembly, Without Slideout Deck 67530-005 .....	7-94
Guardrail Assembly, With Slideout Deck 67530-004 .....	7-96
Guardrail Assembly, Dual Deck 030867-300 .....	7-98
Slideout Deck Assembly, LX50 67886-001 .....	7-100
Slideout Deck Assembly, Rear, 2WD & 4WD Dual Deck 67886-002 .....	7-102
Hose Assembly, LX50, Two Wheel Drive 67533-012 .....	7-104
Hose Assembly, LX50, Four Wheel Drive 67533-013 .....	7-106
Label Kit, LX50, Two Wheel Drive Gas 67532-020 .....	7-108
Diesel 67532-021 .....	7-108
Label Kit, LX50, Four Wheel Drive Gas 67532-022 .....	7-108
Diesel 67532-023 .....	7-108
Label Kit, Two Wheel Drive Dual Deck Gas 67532-038 .....	7-110
Diesel 67532-039 .....	7-110
Label Kit, Four Wheel Drive Dual Deck Gas 67532-040 .....	7-110
Diesel 67532-041 .....	7-110
Dual Fuel Assembly, LX50 Standard 67905-000 .....	7-112
Dual Deck 67905-001 .....	7-112
Generator Option, Gasoline / Propane 67848-000 .....	7-116
Generator Option, Diesel 67849-000 .....	7-118
Removable Controller Option, LX50 61898-000 .....	7-120
Horn Option, 67908-000 .....	7-122
Amber Beacon Option, 67947-000 .....	7-123
Power to Platform Option, 67907-000 .....	7-124
Outrigger Option, 67950-000 .....	7-126
Outrigger Assembly, Dual Deck 67950-001 .....	7-126
Control Box Assembly with Outrigger 67957-000 .....	7-128
Control Box Assembly with Outrigger, Dual Deck 67957-001 .....	7-132
Valve Block Assembly with Outrigger 67956-000 .....	7-135
Controller Assembly with Outrigger 67954-000 .....	7-136
Motion Alarm Option 67909-000 .....	7-137

## List of Illustrations

Figure No.	Title	Page No.
1-1:	LX 50 Work Platform .....	1-1
2-1:	Battery .....	2-1
2-2:	Transporting Work Platform .....	2-1
3-1:	Controls and Indicators .....	3-5
3-2:	Fold Down Guardrails .....	3-10
4-1:	Blocking Elevating Assembly .....	4-3
4-2:	Lubrication .....	4-4
4-3:	Hydraulic Oil Tank and Filter .....	4-5
4-4:	Hydraulic Pump .....	4-6
4-5:	Flow Meter Set-Up .....	4-6
4-6:	Valve Manifold .....	4-7
4-7:	Proportional Controller .....	4-8
4-8:	Platform Down Limit Switch .....	4-8
4-9:	Axle Center Switch .....	4-9
4-10:	Tilt Sensor .....	4-9
4-11:	Hydraulic Manifold, Exploded View .....	4-11
4-12:	Hydraulic Pump .....	4-12
4-13:	Rear Axle Assembly .....	4-12
4-14:	Brake Assembly .....	4-13
4-15:	Rear Drive Motor Assembly .....	4-15
4-16:	Front Axle Assembly .....	4-16
4-17:	Front Drive Motor Assembly .....	4-17
4-18:	Front Drive Motor Assembly, Details .....	4-19
4-19:	Floating Axle Assembly .....	4-21
4-20:	Axle Float Cylinder Cross Section .....	4-21
4-21:	Front Axle Assembly (4WD) .....	4-23
4-22:	Steering Cylinder Cross Section .....	4-23
4-23:	Lift Cylinder Cross Section .....	4-25
4-24:	Outrigger Cylinder Installation .....	4-27
4-25:	Outrigger Cylinder Cross Section .....	4-27
6-1:	Electrical Schematic, Two Wheel Drive, Gasoline-Propane Model .....	6-3
6-2:	Electrical Schematic, Two Wheel Drive, Diesel S/N 1331-2219 .....	6-5
6-3:	Electrical Schematic, Two Wheel Drive, Diesel S/N 2219-Current .....	6-7
6-4:	Electrical Schematic, Four Wheel Drive, Gasoline-Propane Model .....	6-9
6-5:	Electrical Schematic, Four Wheel Drive, Diesel S/N 1331-2219 .....	6-11
6-6:	Electrical Schematic, Four Wheel Drive, Diesel S/N 2219-Current .....	6-13
6-7:	Electrical Schematic, Two Wheel Drive, Gasoline Dual Deck with Outriggers .....	6-15
6-8:	Electrical Schematic, Two Wheel Drive, Diesel Dual Deck with Outriggers .....	6-17
6-9:	Electrical Schematic, Four Wheel Drive, Diesel Dual Deck with Outriggers .....	6-19
6-10:	Hydraulic Schematic, Two Wheel Drive Model .....	6-21
6-11:	Hydraulic Schematic, Four Wheel Drive Model .....	6-23
6-12:	Hydraulic Schematic, Two Wheel Drive Models with Outriggers .....	6-25
6-13:	Hydraulic Schematic, Four Wheel Drive Models with Outriggers .....	6-27
6-14:	Outrigger Valve Components .....	6-28

## List of Illustrations

Figure No.	Title	Page No.
6-15:	Two Wheel Drive Hydraulic Manifold .....	6-29
6-16:	Four Wheel Drive Hydraulic Manifold .....	6-30
6-17:	Kubota Gas Engine Diagram .....	6-31
6-18:	Kubota Diesel Engine Diagram .....	6-32
6-19:	Lower Control Box Cover .....	6-33
6-20:	Terminal Strip, Relay Identification .....	6-33
6-21:	Lower Control Box, Gasoline Model .....	6-34
6-22:	Lower Control Box, Diesel Model .....	6-35
6-23:	Upper Controller .....	6-36
6-24:	Platform Control Box, Gasoline Model .....	6-37
6-25:	Platform Control Box, Diesel Model .....	6-38
6-26:	Platform Control Box, Dual Deck with Outriggers .....	6-39

## List of Tables

Figure No.	Title	Page No.
1-1	Specifications .....	1-2
3-1	Controls and Indicators .....	3-4
4-1	Preventative Maintenance Checklist .....	4-2
4-2	Bolt Torque .....	4-28
4-3	Hydraulic Component Torque .....	4-28
5-1	Troubleshooting Guide .....	5-1
6-1:	Electrical Schematic, Two Wheel Drive, Gasoline / Propane Model .....	6-2
6-2:	Electrical Schematic, Two Wheel Drive, Diesel Model (S/N: 1331-2219) .....	6-4
6-3:	Electrical Schematic, Two Wheel Drive, Diesel Model (S/N: 2219-Current) .....	6-6
6-4:	Electrical Schematic Legend, Four Wheel Drive, Gasoline Model .....	6-8
6-5:	Electrical Schematic, Four Wheel Drive, Diesel Model (S/N: 1331-2219) .....	6-10
6-6:	Electrical Schematic, Four Wheel Drive, Diesel Model (S/N: 2219-Current) .....	6-12
6-7:	Electrical Schematic, Two Wheel Drive, Gasoline Dual Deck with Outriggers .....	6-14
6-8:	Electrical Schematic, Two Wheel Drive, Diesel Dual Deck with Outriggers .....	6-16
6-9:	Electrical Schematic, Four Wheel Drive, Diesel Dual Deck with Outriggers .....	6-18
6-10:	Hydraulic Schematic, Two Wheel Drive .....	6-20
6-11:	Hydraulic Schematic, Four Wheel Drive .....	6-22
6-12:	Hydraulic Schematic, Two Wheel Drive with outriggers .....	6-24
6-13:	Hydraulic Schematic, Four Wheel Drive with outriggers .....	6-26

## 1.0 Introduction

### PURPOSE

The purpose of this service and parts manual is to provide instructions and illustrations for the operation and maintenance of the LX 50 Work Platform manufactured by UpRight, Inc. of Selma, California.

### SCOPE

The manual includes procedures for proper operation, maintenance, adjustment, and repair of this product as well as recommended maintenance schedules and troubleshooting.

## 1.1 General Description

The LX 50 Work Platform consists of the platform, controller, elevating assembly, power module, control module, and chassis.

### Platform

The platform has a reinforced steel floor, 43.5 inch (1.11 m) high guardrails with midrail, 6 inch (152 mm) toeboards and an entrance gate at the rear of the platform. The guardrails can be folded down for access through doors or for shipment.



### WARNING



**DO NOT** use the maintenance platform without guardrails properly assembled and in place.

### Controller

The controller contains the controls to operate the machine. It should be hung on the front, left, or right guardrail, but may be hand held if necessary. To operate the machine, the interlock lever must be depressed to operate any function. A complete explanation of control functions can be found in *Section 3*.

### Elevating Assembly

The platform is raised and lowered by the elevating assembly; a five section scissor assembly powered by a single stage lift cylinder. The hydraulic pump, driven by the engine, powers the cylinder. Solenoid operated valves control raising and lowering.

### Power Module

The power module contains the engine, hydraulic pump, hydraulic reservoir, and starter solenoid.

### Control Module

The control module contains the L.P. bottle and/or fuel tank, hydraulic valve manifold, horn/alarms, volt/hour meter, electrical terminal strips, battery, and chassis control panel. A complete explanation of the chassis control functions is found in *Section 3*.

### Chassis

The chassis is a structural frame that supports all the components of the LX 50 Work Platform.

### PURPOSE OF EQUIPMENT

The objective of the LX 50 Work Platform is to provide a quickly deployable, self propelled, variable height work platform to elevate personnel and materials to overhead work areas and be driven over rough terrain (4WD model only).

### SPECIAL LIMITATIONS

Travel with the platform raised is limited to a creep speed range.

Elevating of the Work Platform is limited to firm, level surfaces **only**. Any degree of slope greater than 2° will lockout the elevating circuits and sound a warning alarm.

Four wheel models: driving while elevated is limited to flat surfaces only. Any degree of pitch in the front axle will lockout the drive, and axle floating circuits when elevated.



### DANGER



The elevating function shall **ONLY** be used when the work platform is level and on a firm surface. The work platform is **NOT** intended to be driven over uneven, rough or soft terrain when elevated.

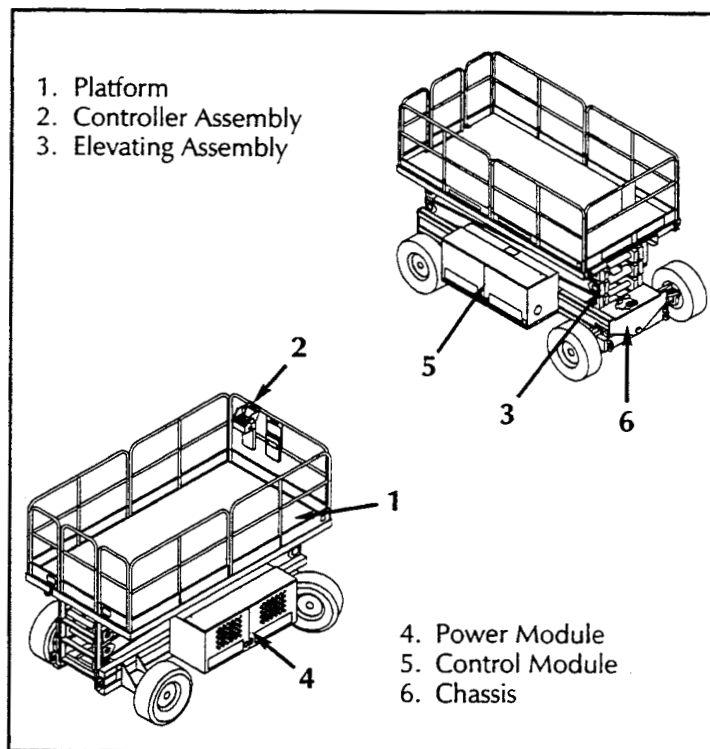

Figure 1-1: LX 50 Work Platform

## 1.2 Specifications

**Table 1-1: Specifications**

\* Specifications subject to change without notice.

Meets or exceeds all applicable requirements of OSHA and ANSI A92.6-1990

ITEM	LX50
<b>Platform Size (Inside Toeboards)</b>	
Standard	143.38 in. x 70 in. [3.64 m x 1.78 m]
w/Extension	179.38 in. x 68 in. [4.56 m x 1.73 m]
<b>Double Deck Models</b>	
w/Decks Retracted	156 in. x 68 in. [3.96 m x 1.73 m]
w/Decks Extended	231 in. x 68 in. [5.87 m x 1.73 m]
<b>Max. Platform Capacity</b>	
Standard	1,000lbs. [454 kg]
w/ Extension	1,000 lbs. [454 kg]
on Extension	500 lbs. [227 kg]
<b>Double Deck Models</b>	750 lbs. [340 kg]
on Extension (one end only)	500 lbs. [227 kg]
<b>Max. No. of occupants</b>	
Standard	4 people
on Extension	2 people
<b>Double Deck Models</b>	4 people
on Extension (one end only)	2 people
<b>Height</b>	
Working Height	56 ft. [17 m]
Max. Platform Height	49 ft. 6 in. [15.09 m]
Min. Platform Height	76 in. [1.93 m]
<b>Dimensions</b>	
Weight, Standard	2wo: 12,220 lbs. [5,534 kg] 4wo: 12,480 lbs. [5,656 kg]
w/ Extension	2wo: 12,690 lbs. [5,756 kg] 4wo: 12,960 lbs. [5,879 kg]
Double Deck	2wo: 13,690 lbs. [6,119 kg] 4wo: 14,460 lbs. [6,559 kg]
Overall Width	90 in. [2.29 m]
Overall Height	118.25 in. [3 m]
Overall Length, Standard	160.5 in. [4.08 m]
<b>Driveable Height Standard</b>	49 ft. 6 in. [15.09 m]
<b>Driveable Height Dual Deck</b>	40 ft. 6 in. [12.34 m]
<b>Surface Speed</b>	
Platform Lowered	0 to 3.1 mph [0 to 5.0 km/h]
Platform Raised	0 to 0.3 mph [0 to .48 km/h]
<b>System Voltage</b>	12 Volt DC
<b>Hydraulic Tank Capacity</b>	28.3 Gallons [107.13 l]
<b>Maximum Hydraulic System Pressure</b>	3000 psi [206.8 bar]
<b>Hydraulic Fluid</b>	
Normal Use (>32°F [0°C])	ISO #46
Low Temp. Use (-10 to 32°F [-23 to 0°C])	5W-20 Motor Oil
<b>Lift System</b>	Two Single Stage Lift Cylinders
<b>Lift Speed</b>	Raise, 45 sec./Lower, 65 sec.
<b>Platform Leveling (Optional)</b>	8.5° (12in. [.3m]) Side/Side 6° (12in. [.3m]) Fore/Aft
<b>Power Source</b>	Diesel or Gasoline 20 HP Kubota, 3 Cylinder, Water Cooled Engine
<b>Drive Control</b>	Proportional
<b>Control System</b>	Smooth one hand Joystick
<b>Horizontal Drive</b>	2wo: 2 Hyd. Wheel Motors 4wo: 4 Hyd. Wheel Motors
<b>Tires</b>	10-16.5 NHS 8 Ply, Foam Filled
<b>Parking Brakes</b>	Two, Spring Applied, Hydraulic Release, Multiple Disc
<b>Turning Radius (inside)</b>	48 in. [1.22 m]
<b>Maximum Gradeability</b>	2wo: 30% [16.7°] 4wo: 24% [13.5°]
<b>Wheel Base</b>	115.75 in. [2.94 m]
<b>Guardrails</b>	43.5 in. [1.1 m] high, Fold Down with Self Closing Gate
<b>Toeboard</b>	6 in. [152 mm] High



**NOTE:** Read and familiarize yourself with all operating instructions before attempting to operate the LX 50 Work Platform.

## 2.1 Preparation for Use

**⚠ CAUTION ⚠**

STAND CLEAR when cutting the metal banding to avoid being cut if the banding snaps back.

1. Remove the metal banding from the module covers and elevating linkage.
2. Remove the banding from the control console.
3. Remove tie wraps holding guardrail gate.
4. Connect the negative (-) lead to the negative (-) battery terminal in power module (Figure 2-1).

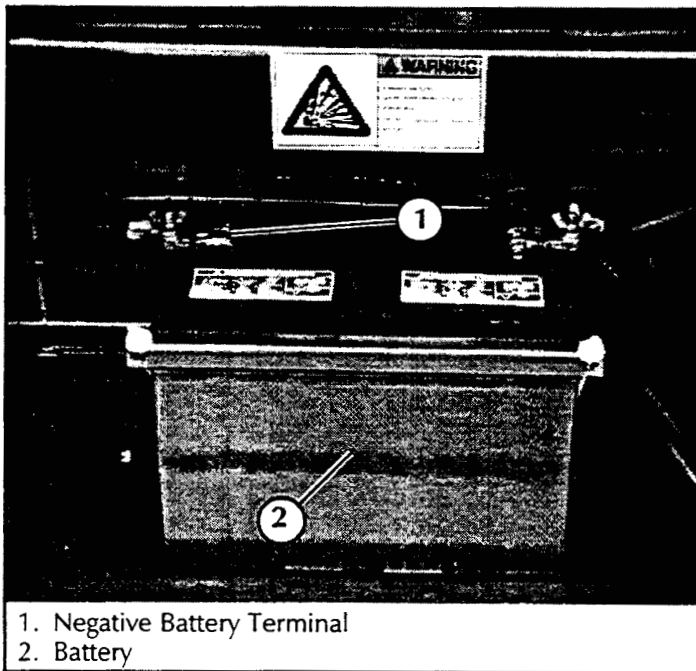

**Figure 2-1: Battery**

## 2.2 Transporting Work Platform

### By Crane

1. Secure straps to chassis tie down/lifting lugs only (Figure 2-2).

### By Truck

1. Maneuver the work platform into transport position and chock wheels.
2. Secure the work platform to the transport vehicle with chains or straps of adequate load capacity attached to the chassis tie down/lifting lugs.

**⚠ CAUTION ⚠**

Overtightening of chains or straps through tie down lugs may result in damage to work platform.

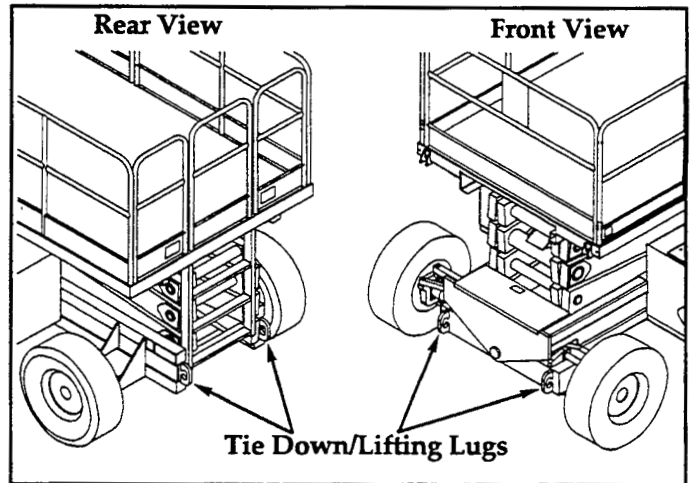

**Figure 2-2: Transporting Work Platform**

## 2.4 Preparation for Shipment

1. Grease all the grease fittings (see Section 4.4).
2. Fully lower the platform.
3. Disconnect the battery negative (-) lead from the battery terminal (Figure 2-1).
4. Band the controller to the front guardrail.
5. Band the elevating linkage to the frame.

## 2.5 Storage

No preparation for storage is required when the work platform is in normal usage. Regular maintenance procedures should continue to be performed (see Figure 4-1 and Table 4-1).

If the work platform is to be placed in long term storage (dead storage), follow the recommended preservation procedures, below.

### PRESERVATION

1. Clean painted surfaces. If the paint is damaged, repaint.
2. Fill the hydraulic tank to operating level, fluid will be visible at the Sight Gauge. **DO NOT** fill the hydraulic tank while the platform is elevated.

**NOTE: DO NOT drain the hydraulic system prior to long term storage.**

3. Coat exposed portions of extended cylinder rods with a preservative such as multipurpose grease and wrap with barrier material.
4. Coat all exposed unpainted metal surfaces with preservative.
5. Service the engine according to the manufacturers recommendations.

### BATTERY

1. Disconnect the battery negative (-) cable and secure to the chassis.
2. Disconnect the remaining battery leads and secure to the chassis.
3. Remove the battery and place in alternate service.

## LX 50

### WARNING

All personnel shall carefully read, understand and follow all safety rules, operating instructions, and the Scaffold Industry Association's MANUAL OF RESPONSIBILITIES (ANSI A92.5) before operating or performing maintenance on any UpRight boom supported aerial work platform.

## SAFETY RULES



**NEVER** operate the machine within ten feet of power lines. **THIS MACHINE IS NOT INSULATED.**

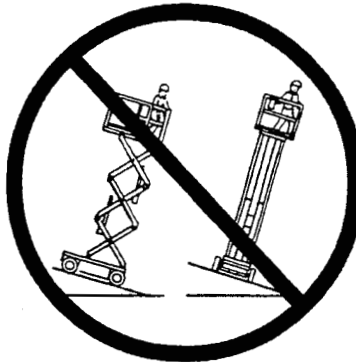

**NEVER** elevate or drive elevated on uneven slopes or soft ground or elevate the platform unless the platform is level.

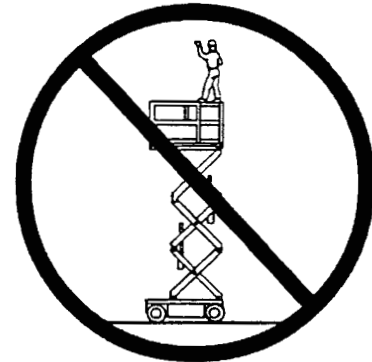

**NEVER** sit, stand or climb on guardrail or midrail.

**NEVER** operate the machine without first surveying the work area for surface hazards such as holes, drop-offs, bumps and debris.

**NEVER** operate the machine if all guardrails are not properly in place and secured with all fasteners properly torqued.

**SECURE** and lock gate after mounting platform.

**KEEP** all body parts clear of outriggers when extending or retracting (outrigger equipped machines only).

**NEVER** use ladders or scaffolding on the platform.

**NEVER** attach overhanging loads or increase platform size.

**LOOK** up, down and around for overhead obstructions and electrical conductors.

**DISTRIBUTE** all loads evenly on the platform. See the back cover for maximum platform load.

**NEVER** use damaged equipment. (Contact UpRight for instructions. See toll-free phone number on back cover.)

**NEVER** change operating or safety systems.

**INSPECT** the machine thoroughly for cracked welds, loose hardware, hydraulic leaks, damaged control cable, loose wire connections and wheel bolts.

**NEVER** climb down elevating assembly with the platform elevated.

**NEVER** perform service on machine while platform is elevated without blocking elevating assembly.

**NEVER** recharge battery near sparks or open flame; batteries that are being charged emit highly explosive hydrogen gas.

**AFTER USE** secure the work platform against unauthorized use by turning key switch off and removing key.

**NEVER** replace any component or part with anything other than original UpRight replacement parts without the manufacturer's consent.

### **California Proposition 65 Warning**

Gasoline and diesel engine exhaust and some of their constituents are known to the State of California to cause cancer, birth defects, and other reproductive harm.

## **RAISING THE PLATFORM**

### ***From the Platform Controls***

Selecting **PLATFORM** at the Chassis/Platform Switch, selecting **LIFT** at the Drive/Lift Switch, and pushing the Control Handle **FORWARD** will energize the Drive/Lift Relay, the Cutout Relay (the Cutout Relay will only stay energized if the Level Sensor is level within 2°), the Up Relay (completing the circuit to the Up Solenoid Valve), and the Proportional Valve. This will allow oil flow through the Proportional Valve (regulating the speed to a rate which is proportional to the angle of Control Handle deflection), through the Lift Valve, through the Down Valve, and to the Lift Cylinder (raising the Platform).

Machines equipped with outriggers must have them either fully retracted or extended and taking load (see *Leveling the Platform*).

### ***From the Chassis Controls***

Selecting **CHASSIS** at the Chassis/Platform Switch, pressing the Throttle Button, and pressing the Up Button, will energize the Throttle Relay (increasing the Engine R.P.M.), the Proportional Valve (regulating speed through 10 ohm resistor), and the Lift Valve. This will allow oil flow through the Proportional Valve (regulating the speed to a fixed rate which is set by the 10 ohm resistor), through the Lift Valve, through the Down Valve, and to the Lift Cylinder (raising the Platform).

## **LOWERING THE PLATFORM**

### ***From the Platform Controls***

Selecting **PLATFORM** at the Chassis/Platform Switch, and pulling the Control Handle *backward* will energize the Down Relay (completing the circuit to the Down Solenoid Valve), and the Down Alarm Relay (completing the circuit to the Down Alarm). This will sound the down alarm, and allow oil to flow out of the Lift Cylinder, through the Down Orifice (regulating the descent speed), through the Down Valve, through the Lift Valve, and out to the Hydraulic Reservoir.

### ***From the Chassis Controls***

Selecting **CHASSIS** at the Chassis/Platform Switch, and pressing the Down Button will energize the Down Relay (completing the circuit to the Down Solenoid Valve), and the Down Alarm Relay (completing the circuit to the Down Alarm). This will sound the down alarm, and allow oil to flow out of the Lift Cylinder, through the Down Orifice (regulating the descent speed), through the Down Valve, through the Lift Valve, and out to the Hydraulic Reservoir.

## ***Emergency Lowering***

Pulling out on the Emergency Lowering Knob will mechanically open the Down Valve. This will allow oil to flow out of the Lift Cylinder, through the Down Orifice (regulating the descent speed), through the Down Valve, through the Lift Valve, and out to the Hydraulic Reservoir. **The Down Alarm WILL NOT SOUND when lowering the platform with the Emergency Lowering Knob.**

## **LEVELING THE PLATFORM**

### ***(Outrigger equipped machines only.)***

With the Chassis / Platform switch on **PLATFORM**, and the Platform completely lowered, selecting **EXTEND** or **RETRACT** with any outrigger switch will energize the Outrigger Extend / Retract Relays providing power to the Outrigger Solenoid Valves. This will allow oil flow through the Outrigger Orifice (limiting speed), through the Outrigger Valve, over the Counterbalance Valve to extend the Outrigger Cylinder. Return oil flows through the Counterbalance Valve (opened by pilot pressure from the extend side of the circuit), through the Outrigger Valve, and back to the reservoir.

Once an Outrigger is extended, the Outrigger Limit Switch opens breaking the ground circuit to the Drive Relay (disabling drive). The Outrigger Pressure Switches will close when all outriggers are taking load, completing the ground circuit to the Up Relay (enabling lift). When Outriggers are fully retracted, the Outrigger Limit Switches will complete the ground circuit to the Pressure Switch Override Relay, which will complete the ground circuit to the Up Relay (enabling lift).

## DESIGN FEATURES

The LX 50 has the following features to insure safe operation:

1. The Lift Valve will not energize unless the chassis is level.
2. The Floating Front Axle locks in position when platform is elevated.
3. A warning alarm sounds and Drive Valves are de-energized if the work platform should become unlevel while elevated.
4. A motion alarm sounds as the work platform is being lowered.
5. The platform descent rate is controlled by an orifice. The Lift Cylinder is equipped with a holding valve to prevent descent should a leak develop.
6. The drive speed is limited to "creep" speed when operating the work platform while elevated.
7. Drive will not operate while elevated unless the Front Axle is parallel to the Rear Axle.
8. Holding brakes are automatically engaged when the Drive Valves are de-energized from the Controller or from a loss of power.
9. The Platform and Chassis controls are each equipped with an Emergency Stop Switch.
10. Up and Down Buttons are located in the Control Module on the chassis for lifting and lowering the work platform from ground level.
12. The Down Valve can be operated manually by means of a cable linkage in the event of powered function failure.
13. Dynamic braking, and runaway protection are provided by the use of Counterbalance Valves in the drive system.
14. A Level Sensor is used to sense when the machine is unlevel, disabling lift functions, and drive when elevated.
15. Drive is disabled when Outriggers are deployed.
16. When using outriggers, lift is disabled if outriggers are not taking load.

## 3.1 Safety Rules and Precautions

**Always observe the following safety rules and precautions when using the LX 50 Work Platform:**

**NEVER** operate the machine within ten feet of power lines. **THIS MACHINE IS NOT INSULATED.**

**NEVER** elevate the platform or drive the machine while elevated unless the machine is on firm level surface.

**NEVER** sit, stand or climb on guardrail or midrail.

**NEVER** operate the machine without first surveying the work area for surface hazards such as holes, drop-offs, bumps and debris.

**NEVER** operate the machine if all guardrails are not properly in place and secured with all fasteners properly torqued.

**SECURE** and lock gate after mounting platform.

**KEEP** all body parts clear of outriggers when extending or retracting.

**NEVER** use ladders or scaffolding on the platform.

**NEVER** attach overhanging loads or increase platform size.

**LOOK** up, down and around for overhead obstructions and electrical conductors.

**DISTRIBUTE** all loads evenly on the platform.

**NEVER** use damaged equipment. Contact UpRight for instructions.

**NEVER** change operating or safety systems.

**INSPECT** the machine thoroughly for cracked welds, loose hardware, hydraulic leaks, damaged control cable, loose wire connections and wheel bolts.

**NEVER** climb down elevating assembly with the platform elevated.

**NEVER** perform service on machine while platform is elevated without blocking elevating assembly.

**NEVER** recharge battery near sparks or open flame; batteries that are being charged emit highly explosive hydrogen gas.

**AFTER USE** secure the work platform against unauthorized use by turning key switch off and removing key.

**NEVER** replace any component or part with anything other than original UpRight replacement parts without the manufacturer's consent.

**ALWAYS** read, understand, and follow all safety rules and operating instructions, and the Scaffold Industry Association's MANUAL OF RESPONSIBILITIES (ANSI/SIA A92.6-1990) before operating or performing maintenance on any UpRight self propelled aerial work platform.

## 3.2 Controls and Indicators

The controls and indicators for operation of the LX50 Work Platform are shown in Figure 3-1. The name and function of each control and indicator are listed in Table 3-1. The index numbers in Figure 3-1 correspond to the index numbers in Table 3-1. The operator shall know the location of each control and indicator and have a thorough knowledge of the function and operation of each before attempting to operate the unit.

**Table 3-1: Controls and Indicators**

### Controller/Platform

INDEX NO.	NAME	FUNCTION
1	KEY SWITCH	Turn key fully clockwise to start engine, when released key goes to RUN to provide power to the Interlock Switch.
2	EMERGENCY STOP SWITCH	Push red button to cut power to all controls (off). Turn clockwise to provide power (on).
3	CONTROL LEVER	Move joystick forward or backwards to control Drive and Lift Valves proportionally or Down Valve depending on position of Drive Lift Switch.
4	STEERING SWITCH	Moving the momentary rocker switch RIGHT or LEFT steers the work platform in that direction. Although the Steering Switch is self centering the steering system is not. <b>The wheels must be steered back to straight.</b>
5	DRIVE SPEED/TORQUE SELECTOR SWITCH	Provides two speed/torque ranges, in forward or reverse. <b>HIGH SPEED</b> -low torque and <b>HIGH TORQUE</b> -low speed.
6	DRIVE/LIFT SWITCH	Selecting <b>DRIVE</b> allows the work platform to move forward or reverse. Selecting <b>LIFT</b> allows the work platform to raise or lower.
7	INTERLOCK LEVER SWITCH	Provides power to the Controller powered functions, only when depressed, preventing accidental activation of the Controller.
8	DRIVE ENABLE INDICATOR	Illuminates when drive is enabled, turns off when disabled.
9	OUTRIGGER SWITCHES	Push up to extend outriggers, down to retract them.
10	ORBIT LEVEL	Use when leveling machine with outriggers.
11	CHOKE BUTTON (gasoline / dual fuel)	Press to engage choke when starting engine.
	GLOW PLUG BUTTON (diesel)	Press and hold for 6 seconds to preheat glow plugs before starting.

### Chassis

INDEX NO.	NAME	FUNCTION
12	HOURMETER (optional)	Tracks the number of hours of engine powered operation.
13	RAISE BUTTON	Press button to lift the platform and
14	LOWER BUTTON	Press button to lower the platform.
15	EMERGENCY STOP SWITCH	Push red button to cut power to all controls (off). Turn clockwise to provide power (on).
16	FUEL SELECTOR SWITCH (Dual Fuel Only)	Turning switch left or right changes the engine's fuel supply between <b>GASOLINE</b> and <b>PROPANE</b> . Placing the switch in the center position purges the fuel lines prior to changing fuels.
17	EMERGENCY LOWERING VALVE	Pull out to lower the platform in the event of powered function failure.
18	DOWN ALARM*	Sounds an audible signal while platform is lowering during normal operation. If the Emergency Lowering Valve is used the alarm <b>does not</b> sound.
	TILT ALARM*	Sounds an audible signal when the platform is elevated and on a slope of 2° side to side or fore and aft.
19	BRAKE RELEASE PUMP	Releases the Parking Brake allowing the machine to be moved in the event power is lost or for winching onto a trailer. See Section 3.5.
20	START BUTTON	Press to start the engine. Release after engine starts.
21	STOP BUTTON	Press to kill the engine.
22	THROTTLE BUTTON	Press to increase engine RPM when operating functions from the lower control panel.
23	PLATFORM/ CHASSIS SWITCH	Turn switch to the left to enable platform controls. Turn switch to the right to enable chassis controls.
24	CHOKE BUTTON (gasoline / dual fuel)	Press to engage choke when starting engine.
	GLOW PLUG BUTTON (diesel)	Press and hold for 6 seconds to preheat glow plugs before starting.

\* Down Alarm and Tilt Alarm are the same unit with different inputs.



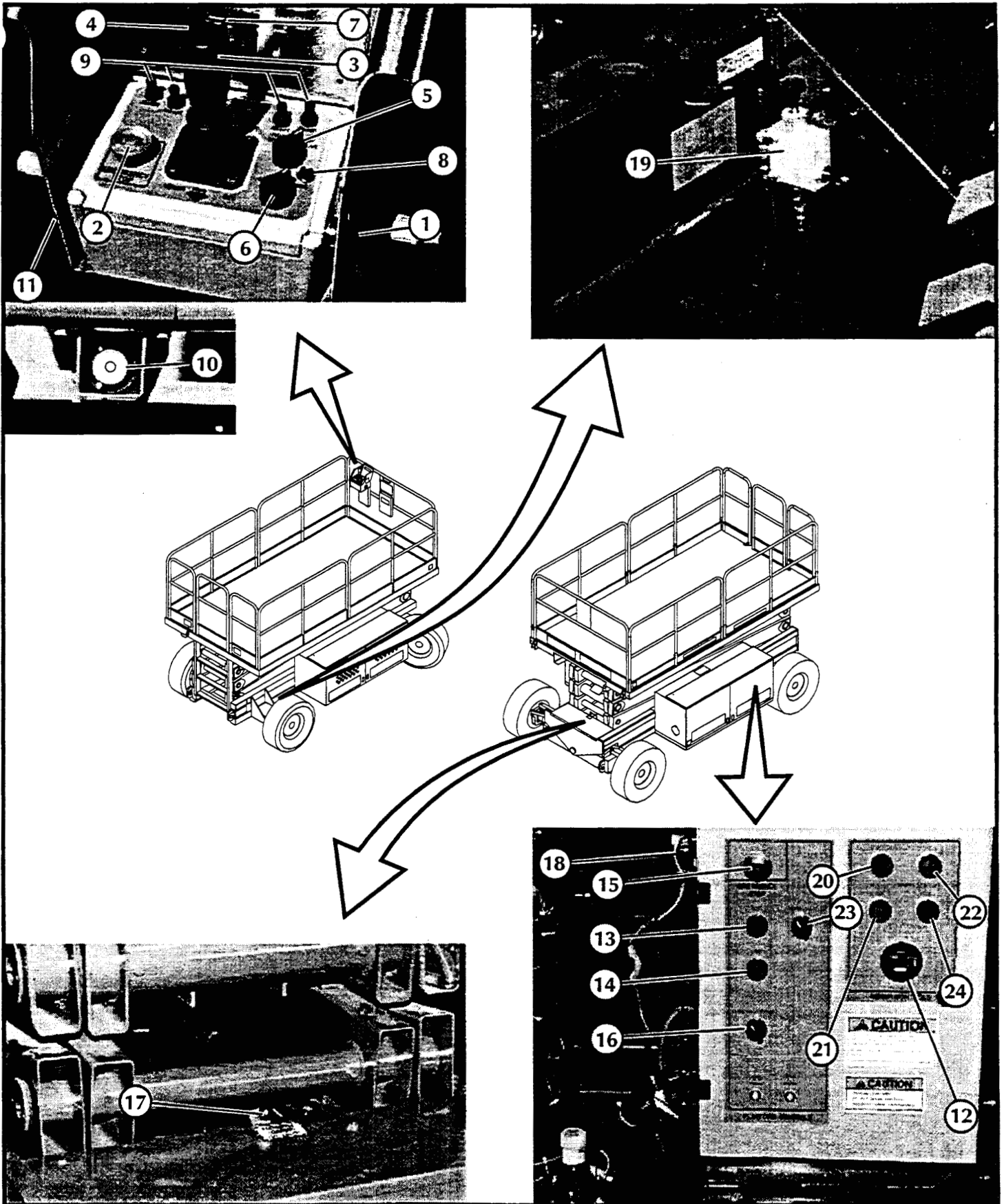

Figure 3-1: Controls and Indicators

### 3.3 Pre-Operation Inspection

**NOTE:** Carefully read, understand and follow all safety rules, operating instructions, labels and the Scaffold Industry Association's **MANUAL OF RESPONSIBILITIES**. Perform the following steps each day before use.

1. Open modules and inspect for damage, oil leaks or missing parts.
2. Check the hydraulic oil level sight gauge on the hydraulic tank with the platform fully lowered. Add ISO #46 hydraulic oil if necessary.
3. Check that fluid level in the battery is correct (See Section 4.3, *Battery Maintenance*).
4. Check the engine oil level and fuel level.
5. Check that all guardrails are in place, the slide out deck extension is secured with the pin and all fasteners are properly tightened.
6. Carefully inspect the entire work platform for damage such as cracked welds or structural members, loose or missing parts, oil leaks, damaged cables or hoses, loose connections and tire damage.
7. Move machine, if necessary, to unobstructed area to allow for full elevation.
8. Place chassis and platform emergency stop switches in the ON position (Figure 3-1) by pulling the buttons out.
9. Verify platform/chassis switch is on **PLATFORM** (Figure 3-1).
10. **Dual Fuel Models:** set dual fuel selector to desired position. Set to the center position to purge the system when switching fuels. If the machine is to be operated on propane, open the supply valve on the tank.

**Note:** When using LP gas, use clean, water free liquid petroleum gas, preferably from a bulk storage tank. Follow the instructions located on the power module tray for filling the tank.

### SYSTEM FUNCTION INSPECTION



#### WARNING



**STAND CLEAR** of the work platform while performing the following checks.

Before operating the work platform survey the work area for surface hazards such as holes, drop-offs, bumps and debris.

Check in **ALL** directions, including above the work platform, for obstructions and electrical conductors.

Protect control console cable from possible damage while performing checks.

1. Unhook controller from front guardrail. Firmly grasp controller hanger in such a manner that the interlock lever can be depressed, while performing the following checks from the ground.
2. Turn controller key switch clockwise to **ON**. Turn fully clockwise to start engine, releasing the key once the engine starts.

**Note:** If the engine is cold, on gasoline / propane models, hold the choke button in while starting the engine. On diesel models, depress the glow plug button and hold for 6 seconds to engage the glow plugs.

3. Position drive/lift switch to **DRIVE** position.
4. With the speed range switch first in **HIGH TORQUE** and then in **HIGH SPEED** depress the interlock lever and slowly push the control lever to **FORWARD** then **REVERSE** positions to check for speed and directional control. The farther you push or pull the control lever the faster the machine will travel.
5. Push steering switch **RIGHT** then **LEFT** to check for steering control.
6. Depress the interlock switch on the control handle and position each outrigger switch to the **EXTEND** position to deploy all four outriggers. Check the drive enable indicator light, it should be off.
7. Fully retract all outriggers and check the drive enable indicator, it should be on.
8. Rehook controller on front guardrail.
9. Turn the platform/chassis switch to **CHASSIS**.
10. Push the throttle button in. Push chassis raise button to elevate platform while pushing the tilt sensor (Figure 1) off of level. The platform should only partially elevate and the tilt alarm should sound. If the platform continues to elevate and/or there is no alarm **STOP** and remove the machine from service until it is repaired.



#### WARNING



If you smell propane, close the supply valve on the tank immediately until you have located and corrected the leak.

11. While the engine is cool check the engine coolant level.



#### CAUTION



**DO NOT** check coolant when engine or radiator is hot, hot coolant can cause severe burns.

11. Release the tilt sensor and fully elevate platform.
12. Visually inspect the elevating assembly, lift cylinder, cables and hoses for damage or erratic operation. Check for missing or loose parts.
13. Lower the platform partially by pushing in on the chassis lower switch, and check operation of the audible lowering alarm.
14. Open the chassis emergency lowering valve (Figure 3-1) to check for proper operation by pulling and holding the knob out. Once the platform is fully lowered, close the valve by releasing the knob.
15. Turn the platform/chassis switch to **PLATFORM**.
16. Mount the platform making sure the gate is latched.
17. Position drive/lift switch to **LIFT**.
18. Depress the interlock lever and slowly push the control lever to **UP** to raise the platform, fully actuate the control lever to check proportional lift speed. Slowly pull control lever to **DOWN** position to lower platform. Check that lowering alarm sounds.
19. Depress the interlock switch on the control handle and position any outrigger switch to the **EXTEND** position, outriggers should be disabled. If an outrigger extends during this test STOP. Lower the platform and remove the machine from service until it is repaired.
20. Turn controller key switch to **OFF**, push the emergency stop button and dismount the platform.
21. Close and secure module covers.

## 3.4 Operation

**Note:** Before operating work platform, ensure that the pre-operation and safety inspection has been completed, any deficiencies have been corrected and the operator has been thoroughly trained on this machine.

### TRAVEL WITH PLATFORM LOWERED

1. Verify chassis emergency stop switch is in the ON position (turn counterclockwise), the drive enable indicator (if equipped) is on, and that the platform/chassis switch is on **PLATFORM**.

**Note:** If the drive enable indicator is off, verify that the platform is fully lowered and (if so equipped) the outriggers are all fully retracted.

2. After mounting platform, close and latch gate. Check that guardrails are in position and properly assembled with fasteners properly torqued.
3. Check that route is clear of persons, obstructions, holes and drop-offs and is capable of supporting the wheel loads.
4. Check clearances above, below and to the sides of the platform.
5. Pull controller emergency stop button out to ON position.
6. Turn controller key switch fully clockwise to start engine, releasing the key once the engine starts.

**Note:** If the engine is cold, on gasoline / propane models, hold the choke button in while starting the engine. On diesel models, depress the glow plug button and hold for 6 seconds to engage the glow plugs.

7. Set the drive/lift speed range switch to **HIGH TORQUE**.
8. Grasp the control lever so the interlock lever is depressed (releasing the interlock lever cuts power to controller). Slowly push or pull the control lever to **FORWARD** or **REVERSE** to travel in the desired direction. The farther you push or pull the control lever from center the faster the machine will travel.
9. While moving, push the drive/lift speed range switch to **HIGH SPEED** for travel on level surfaces or to **HIGH TORQUE** for climbing grades or traveling in confined areas.

### Steering

1. Push the steering switch **RIGHT** or **LEFT** to turn the wheels. Observe the tires while maneuvering to insure proper direction.

**Note:** Steering is not self-centering. Wheels must be returned to the straight ahead position by operating the steering switch.

### Leveling the Platform (Outrigger equipped machines only)

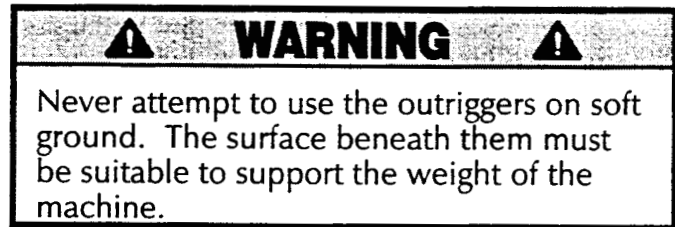

1. Look around the machine, make sure that there is nothing obstructing the outriggers, and that the surface beneath them is suitable to support the weight of the machine.
2. Depress the interlock lever on the control handle and operate the outrigger switches to extend each outrigger until it is making firm contact with the ground.
3. While observing the bubble level on the front guardrail (fig. 3), extend the outrigger opposite the position of the bubble until the platform is level. For example: if the bubble is to the front and left in the orbit, extend the rear right outrigger. Continue to adjust until the bubble is centered in the small circle indicating that the platform is level.
4. Outriggers must be in firm contact with the supporting surface, observe each outrigger to verify.

### To retract the outriggers:

1. Fully lower the platform.
2. Position each outrigger switch to **RETRACT**. Observe the outriggers to ensure that they are fully retracted. The drive enable indicator light will not come on until all four outriggers are fully retracted.

### RAISING AND LOWERING THE PLATFORM

1. Position the drive/lift switch to **LIFT**.
2. While holding the control lever so the interlock lever is depressed, push the control lever slowly to **UP** to raise the platform. Pushing the control lever farther increases the lift speed.
3. When the work task is completed, position the drive/lift switch to **LIFT** and lower the platform by pulling back on the control lever until the platform is fully lowered.

## **TRAVEL WITH WORK PLATFORM ELEVATED**

Travel with platform elevated **ONLY** on firm and level surfaces.

**Note: The work platform will travel at reduced speed when in the elevated position, and only if the front axle is parallel with the rear axle.**

1. Check that the route is clear of persons, obstructions, holes and drop-offs, is level and capable of supporting the wheel loads.
2. Check clearances above, below and to the sides of platform.
3. Position the drive/lift switch to the **DRIVE** position.
4. Push the control lever to **FORWARD** or **REVERSE** for the desired direction of travel.

**If the machine quits driving and the tilt alarm sounds, immediately lower the platform and move the machine to a level location before re-elevating the platform.**

## **EMERGENCY LOWERING**

The emergency lowering valve is located at the front of the machine at the base of the scissor assembly, (Figure 3-1).

1. Open the emergency lowering valve by pulling on the knob and holding it.
2. Once the platform is fully lowered, release the knob to close the valve.

## **SWITCHING FUELS (DUAL FUEL ONLY)**

1. With engine running turn the fuel selector switch (Figure 3-1) to the center position.
2. After the engine has quit running select the appropriate fuel supply.
3. Restart the engine.

## **AFTER USE EACH DAY**

1. Ensure that the platform is fully lowered.
2. Park the machine on level ground, preferably under cover, secure against vandals, children or unauthorized operation.
3. Turn the key switch to **OFF** and remove the key to prevent unauthorized operation.

## **3.5 Parking Brake Release (Figure 3-1)**

Perform the following only when the machine will not operate under its own power and it is necessary to move the machine or when winching onto a trailer to transport.

1. Close the needle valve by turning the knob clockwise.
2. Pump the brake release pump until the parking brakes release and the wheels can be turned.
3. The machine will now roll when pushed or pulled.
4. Be sure to open the needle valve and verify that the parking brakes have engaged before the machine is operated.

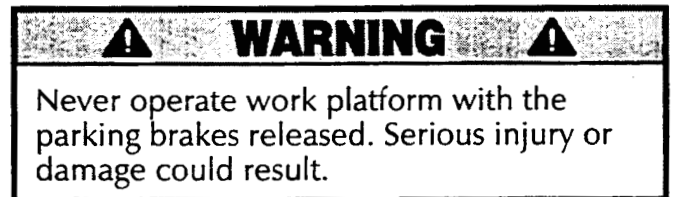

## 3.6 Fold Down Guardrails (Figure 3-2)

This procedure is only for passing through doorways. Guardrails must be returned to proper position before using the machine.

### FOLD DOWN PROCEDURE (FIGURE 3-2)

**Note:** When performing the following procedures retain all fasteners.

1. Place controller on platform.
2. Starting at the front of the platform, remove nuts, bolts and washers from the top of the front guardrail. Fold the front guardrail down onto the platform.
3. Close and latch the gate.
4. Remove nuts, bolts and washers from the top of the rear guardrail. Fold the rear guardrail down onto the platform being careful to keep gate latched at all times.
5. Remove nuts, bolts and washers from the top of the side guardrails. Lift up and fold one side guardrail in so it rests on the deck. Repeat with other side guardrails.

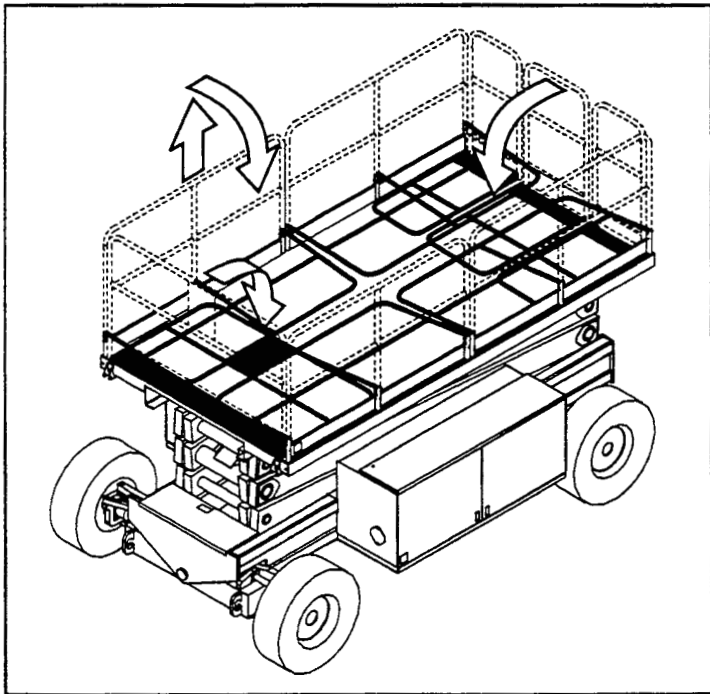

Figure 3-2: Fold Down Guardrails

### ERECTION PROCEDURE

1. Raise side guardrails making sure each is pushed down to secure the guardrail in the vertical position.
2. Install bolts, washers and nuts between the side guardrails, tighten securely.
3. Raise rear guardrail assembly, aligning holes and install bolts, washers and nuts. Tighten securely.
4. Raise front guardrail, aligning holes and install bolts, washers and nuts. Tighten securely.
5. Hang controller from front guardrail.
6. Before operating work platform check that all fasteners are in place and properly torqued.



### WARNING



Before operating machine, guardrails must be securely fastened in their proper position.



## Double Deck Fold Down Procedure (Figure 3-3)

**Note:** When performing the following procedures retain all fasteners.

1. Place controller on platform.
2. Starting at the front slide out deck, remove nuts, bolts and washers from the top front corners of guardrails. Remove the nuts, bolts and washers from the slide out deck side guardrail midrails. Also remove nuts, bolts and washers located at the top of the sockets that hold the slide out deck side guardrails to the deck. Fold the side guardrails down onto the platform.
3. Follow step 2 to fold the side guardrails on the rear slide out deck.
4. Unlatch the gate so the left side guardrails can be folded down in two separate pieces. Also remove the nuts, bolts and washers opposite the gate latch on the right side guardrail so it too can be separated into two pieces.
5. Lift up and fold side guardrails in so they rest on the deck.
6. Lift up and fold front guardrail in so it rests on the deck. Repeat for rear guardrail.

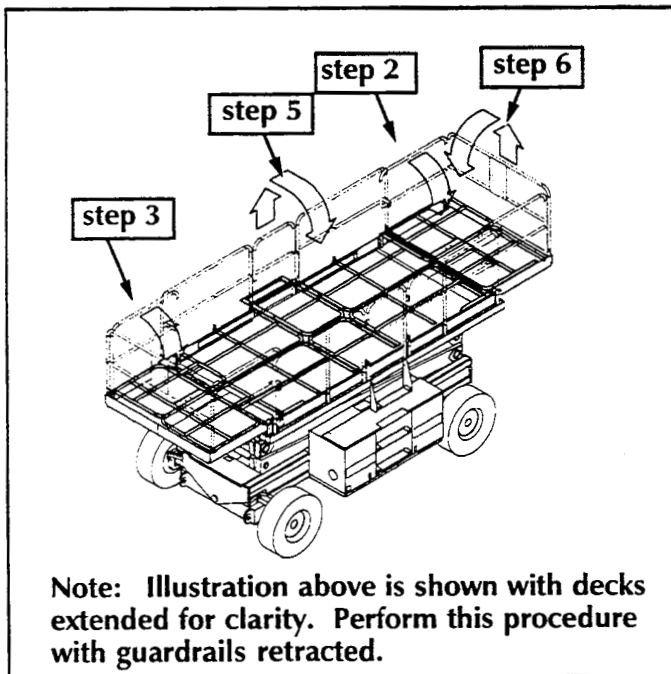

Figure 3-3: Fold Down Guardrails (Double Deck)

## ERECTION PROCEDURE

1. Raise front guardrail making sure it is pushed down to secure the guardrail in the vertical position. Repeat for rear guardrail.
2. Raise side guardrails making sure each is pushed down to secure the guardrail in the vertical position, align holes and install bolts, washers and nuts. Tighten securely.
3. Raise one of the four slide out deck side guardrail assemblies, align holes and install bolts, washers and nuts. Tighten securely. Repeat this procedure for the other three slide out deck side guardrails.
4. Hang controller from front guardrail.
5. Before operating work platform check that all fasteners are in place and properly torqued.

<b>⚠ WARNING ⚠</b>
Before operating machine, guardrails must be securely fastened in their proper position.

NOTES:

## 4.0 Introduction

### **⚠ WARNING ⚠**

Be sure to read, understand and follow all information in the *Operation Section* of this manual before attempting to operate or perform service on any LX50 Work Platform.

**NOTE: For Information on the engine refer to your local engine dealer.**

This section contains instructions for the maintenance of the LX50 Work Platform. Procedures for the operation inspection, adjustment, scheduled maintenance, and repair/removal are included.

Referring to *Section 3.0* will aid in understanding the operation and function of the various components and systems of the LX50 and help in diagnosing and repair of the machine.

Refer to Table 4-1, Preventative Maintenance Checklist, for recommended maintenance intervals.

### **SPECIAL TOOLS**

The following is a list of special tools which may be required to perform certain maintenance procedures on the LX50 work platform.

- 0-1000 PSI Hydraulic Pressure Gauge  
with Adapter Fittings
- 0-3000 PSI Hydraulic Pressure Gauge  
with Adapter Fittings
- 0-30 Gallon Hydraulic Flow Meter  
With 0-3000 P.S.I. Simulated Load and Adapter  
Fittings (UpRight P/N 67040-000)
- Small Deutsch Connector Field Kit  
(UpRight P/N 030899-000)
- Large Deutsch Connector Field Kit  
(UpRight P/N 030898-000)
- Inclinometer

## 4.1 Preventative Maintenance (Table 4-1)

The Complete inspection consists of periodic visual and operational checks, together with all necessary minor adjustments to assure proper performance. Daily inspection will prevent abnormal wear and prolong the life of all systems. The inspection and maintenance schedule is to be performed at regular intervals. Inspection and maintenance shall be performed by personnel who are trained and familiar with mechanical and electrical procedures.

### **⚠ WARNING ⚠**

Before performing preventative maintenance, familiarize yourself with the operation of the machine.  
Always block the elevating assembly whenever it is necessary to enter the scissor assembly to perform maintenance while the platform is elevated.

The preventative maintenance table has been designed to be used primarily for machine service and maintenance repair. Please photocopy the following page and use this table as a checklist when inspecting the machine for service.

## Preventative Maintenance Table Key

### Interval

- Daily=each shift or every day
- 50h/30d=every 50 hours or 30 days
- 250h/6m=every 250 hours or 6 months
- 1000h/2y=every 1000 hours or 2 years

- Y=Yes/Acceptable
- N=No/Not Acceptable
- R=Repaired/Acceptable

## Preventative Maintenance Report

Date:	_____
Owner:	_____
Model No:	_____
Serial No:	_____
Serviced By:	_____
Service Interval:	_____

**Table 4-1: Preventative Maintenance Checklist**

COMPONENT	INSPECTION OR SERVICES	INTERVAL	Y	N	R
Battery	Check electrolyte level	6M			
	Check specific gravity	6M			
	Clean exterior	6M			
	Check battery cable condition	Daily			
	Clean terminals	6M			
Engine Oil and Filter	Check level and condition	Daily			
	Check for leaks	Daily			
	Change oil filter	100H			
Engine Fuel System	Check fuel level	Daily			
	Check for leaks	Daily			
	Replace fuel filter	6M			
	Check air cleaner	Daily			
Engine Coolant	Check coolant level (with engine cold)	Daily			
	Replace coolant	3M			
Hydraulic Oil	Check oil level	Daily			
	Change filter	6M			
	Drain and replace oil	2Y			
Hydraulic System	Check for leaks	Daily			
	Check hose connections	30D			
	Check hoses for exterior wear	30D			
Emergency Hydraulic System	Operate the emergency lowering valve and check for serviceability	Daily			
Controller	Check switch operation	Daily			
Control Cable	Check the exterior of the cable for pinching, binding or wear	Daily			
Platform Deck and Rails	Check fasteners for proper torque	Daily			
	Check welds for cracks	Daily			
	Check condition of deck	Daily			
Tires	Check for damage	Daily			
	Check lug nuts (torque to 150 ft. lbs. [203 Nm])	30D			

**Table 4-1: Preventative Maintenance Checklist (cont'd.)**

COMPONENT	INSPECTION OR SERVICES	INTERVAL	Y	N	R
Hydraulic Pump	Wipe clean	30D			
	Check for leaks at mating surfaces	30D			
	Check for hose fitting leaks	Daily			
	Check mounting bolts for proper torque	30D			
Drive Motors	Check for operation and leaks	Daily			
Torque Hubs	Check for leaks	Daily			
	Check Oil level	250H/6M			
	Change Oil after break-in	50H/30D			
	Change Oil	1000h/2y			
Steering System	Check hardware & fittings for proper torque	6M			
	Grease pivot pins	30D			
	Oil king pins	30D			
	Check steering cylinder for leaks	30D			
	Inspect for structural cracks	Daily			
Elevating Assembly	Check pivot points for wear	30D			
	Check mounting pin pivot bolts for proper torque	30D			
	Check elevating arms for bending	6M			
	Grease linkage pins	30D			
Chassis	Check hoses for pinch or rubbing points	Daily			
	Check component mounting for proper torque	6M			
	Check welds for cracks	Daily			
Lift Cylinder	Check the cylinder rod for wear	30D			
	Check mounting pin pivot bolts for proper torque	30D			
	Check seals for leaks	30D			
	Inspect pivot points for wear	30D			
	Check fittings for proper torque	30D			
Axle Cylinder	Check the cylinder rod for wear	30D			
	Check mounting pin pivot bolts for proper torque	30D			
	Check seals for leaks	30D			
	Inspect pivot points for wear	30D			
	Check fittings for proper torque	30D			
Entire Unit	Check for and repair collision damage	Daily			
	Check fasteners for proper torque	3M			
	Check for corrosion-remove and repaint	6M			
	Lubricate	30D			
Labels	Check for peeling, missing, or unreadable labels & replace	Daily			

## 4.2 Blocking Elevating Assembly (Figure 4-1)

### ⚠ WARNING ⚠

Never perform service on the work platform in the elevating assembly area while platform is elevated without first blocking the elevating assembly.

DO NOT stand in elevating assembly area while deploying or storing brace.

### Installation

1. Park the work platform on firm level ground.
2. Verify platform emergency stop switch is ON.
3. Turn platform/chassis switch to **CHASSIS**.
4. Start the engine using the chassis controls.
5. Push the throttle button in, the button will stay in and the engine speed will increase. Using the raise button, elevate platform until the scissors brace can be rotated to the vertical position.
6. From the left side of the machine, disengage the locking pin securing the brace. Rotate the scissor brace counterclockwise until it is vertical and between the two scissor center pivots.
7. Push lower button and gradually lower platform until brace is supporting the platform.
8. Disengage throttle by pushing throttle button in again, the button will retract and the engine will come to idle speed.

### Removal

1. Using chassis controls, gradually raise platform until the scissors brace clears the two scissor center pivots.
2. Rotate scissors brace clockwise until the locking pin engages.
3. Push lower button to completely lower platform.
4. Make sure the throttle button is disengaged and platform/chassis switch is on **PLATFORM**.

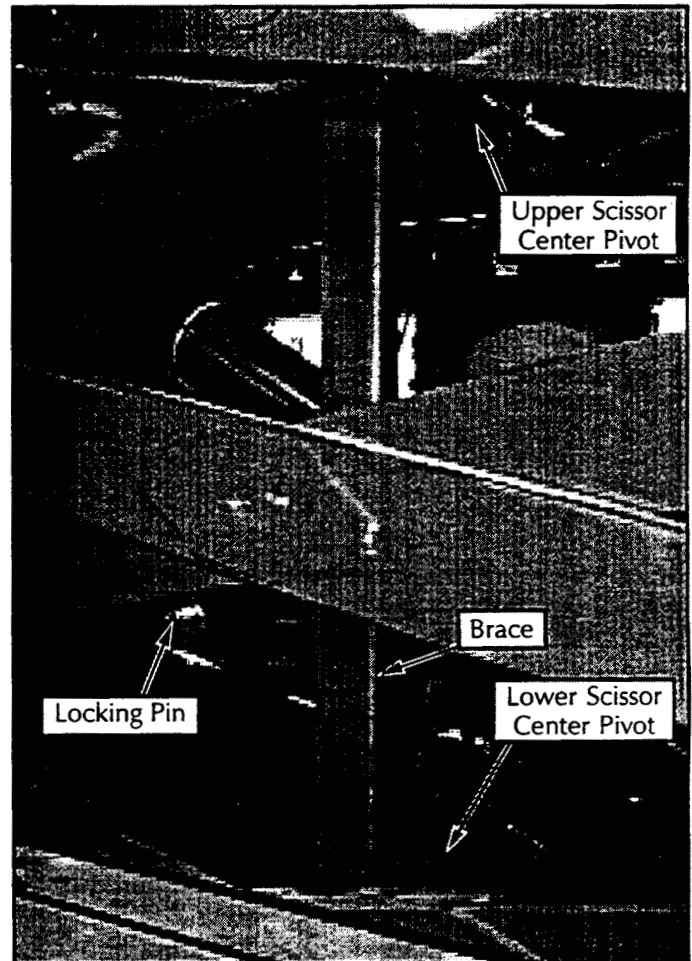

Figure 4-1: Blocking Elevating Assembly

## 4.3 Battery Maintenance

### ⚠ WARNING ⚠

Hazard of explosive gas mixture. Keep sparks, flame, and smoking material away from battery.

Always wear safety glasses when working with batteries.

Battery fluid is highly corrosive. Thoroughly rinse away any spilled fluid with clean water.

## BATTERY INSPECTION AND CLEANING

Check battery fluid level daily, especially if work platform is being used in a warm, dry climate. If required, add distilled water ONLY. Use of tap water with high mineral content will shorten battery life.

The battery and cables should be inspected regularly for signs of cracks in the case, electrolyte leakage and corrosion of the terminals. Inspect cables for worn spots or breaks in the insulation and for broken cable terminals.

Clean the battery when it shows signs of corrosion at the terminals or when electrolyte has overflowed during charging. Use a baking soda solution to clean the battery, taking care not to get the solution inside the cells. Rinse thoroughly with clean water. Clean battery and cable contact surfaces to a bright metal finish whenever a cable is removed.

## 4.4 Lubrication

Refer to Table 4-1 for the lubrication intervals and Figure 4-2 for location of items that require lubrication service. Refer to the appropriate sections for lubrication information on the Steering Linkage, Torque hubs, Hydraulic Oil and Filter, and Engine Oil and Filter.

### GREASE FITTINGS

Wipe each grease fitting before and after greasing. Using multipurpose grease in a grease gun, pump the grease into the fitting until grease just begins to appear at the edges of the pivot, wipe off any excess grease.

### STEERING LINKAGE

Apply one or two drops of penetrating oil to each pivot and King Pin bearing.

## TORQUE HUBS

Note: Change oil in torque hubs after the first 50 hours of operation. Change every 1000 hours thereafter.

1. Remove Torque Hub from rear drive assembly (refer to section 4.9).
2. Remove drain plug from underside of Torque Hub.
3. Drain oil from unit.
4. Replace drain plug.
5. Remove fill plug from top side of torque hub.
6. Fill unit with 90 wt. gear oil.
7. Replace fill plug.

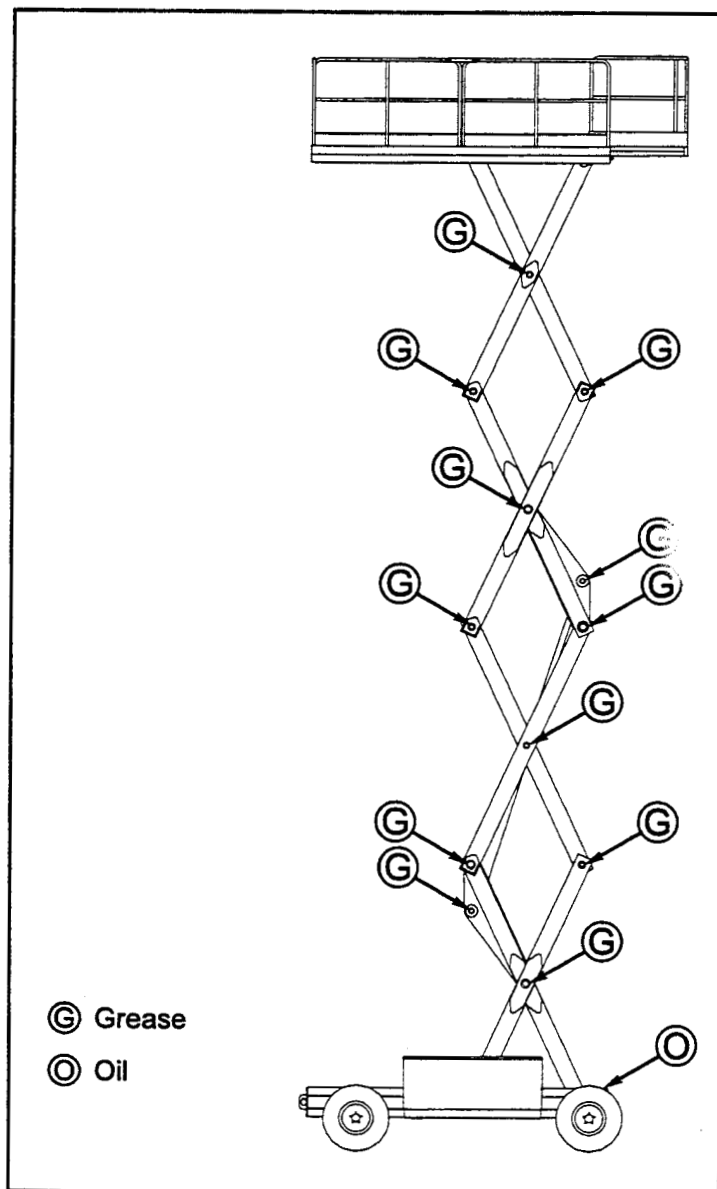

Figure 4-2: Lubrication Chart



## HYDRAULIC OIL AND FILTER

### Fluid Level

With the platform fully lowered, the oil should be visible in the Sight Gauge. If the oil is NOT visible, fill the tank until the oil can be seen. DO NOT fill above the Sight Gauge or when the Platform is elevated.

### Oil and Filter Replacement

1. To change the filter only, follow Steps 5, 6, and 7.

### ⚠ CAUTION ⚠

The hydraulic oil may be hot enough to cause burns. Wear safety gloves and safety glasses when handling hot oil.

2. Provide a suitable container to catch the drained oil. The hydraulic tank has a capacity of 12.0 gallons (45.5 l).
3. Remove the drain plug and allow all oil to drain into the container, be sure to dispose of oil properly.
4. Reinstall the drain plug.
5. Remove the three screws from the filter body cover and open the filter body.

6. Lift the filter element from the filter body.
7. Fill the hydraulic oil tank to the level of the sight gauge with ISO #46 hydraulic oil.
8. Insert the replacement filter element into the filter body and press into position.
9. Replace the filter body cover and screws.

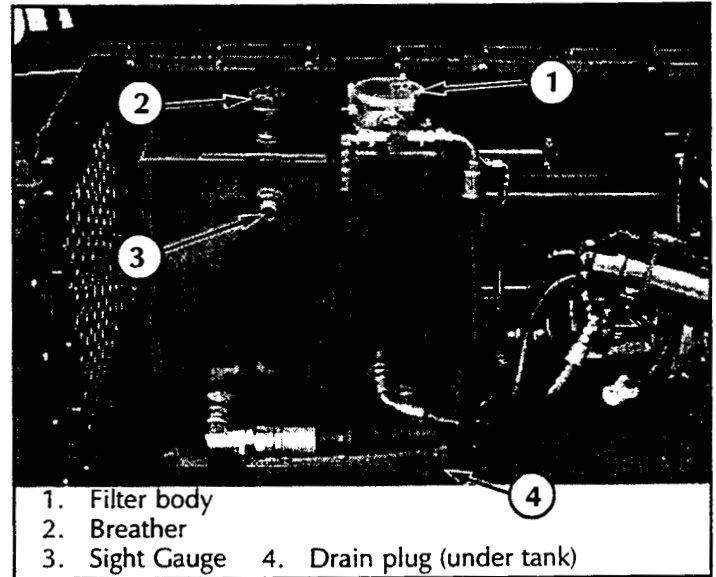

Figure 4-3: Hydraulic Oil Tank and Filter

## 4.5 Setting Hydraulic Pressures

**Note:** Follow Pump Set - Up procedure whenever Pump has been replaced, or when testing performance to isolate possible failure. Refer to figure 4-5 for flow meter set - up.

### PUMP SET-UP

1. Remove Pump output line and cap it.
2. Install flow meter input line to Pump output.
3. Remove Tank return line and cap.
4. Install flow meter output line to Tank.
5. Remove sense line from Pump.
6. Install flow meter sense line to Pump.
7. Remove caps on Standby and Max Pressure adjustment screws.
8. Press and hold Throttle Button to rev up engine.
9. Close simulated load flow control valve by turning fully clockwise.
10. Turn Standby pressure adjustment screw fully clockwise.
11. Adjust Max Pressure to 3000 P.S.I. (clockwise to increase, counterclockwise to decrease).
12. Turn Standby pressure adjustment screw counterclockwise until gauge reads 200 P.S.I.
13. Replace caps on Standby and Max Pressure adjustment screws.
14. Open simulated load flow control valve by turning fully counterclockwise.
15. Open simulated load pressure relief valve by turning fully counterclockwise.
16. Loosen large locknut on Horsepower Limiter Valve and turn adjustment screw counterclockwise two full turns.
17. Increase simulated load pressure relief valve by turning clockwise until gauge reads 1500 P.S.I.
18. Turn Horsepower Limiter adjustment screw clockwise until flow meter reads 12 G.P.M.
19. Tighten large locknut on Horsepower Limiter Valve.
20. Loosen small locknut on Horsepower Limiter Valve and turn adjustment screw counterclockwise two full turns.
21. Increase simulated load pressure relief valve by turning clockwise until gauge reads 2500 P.S.I.
22. Turn Horsepower Limiter Valve adjustment screw clockwise until flow meter reads 7 G.P.M.
23. Tighten small locknut on Horsepower Limiter Valve.
24. Replace hoses.

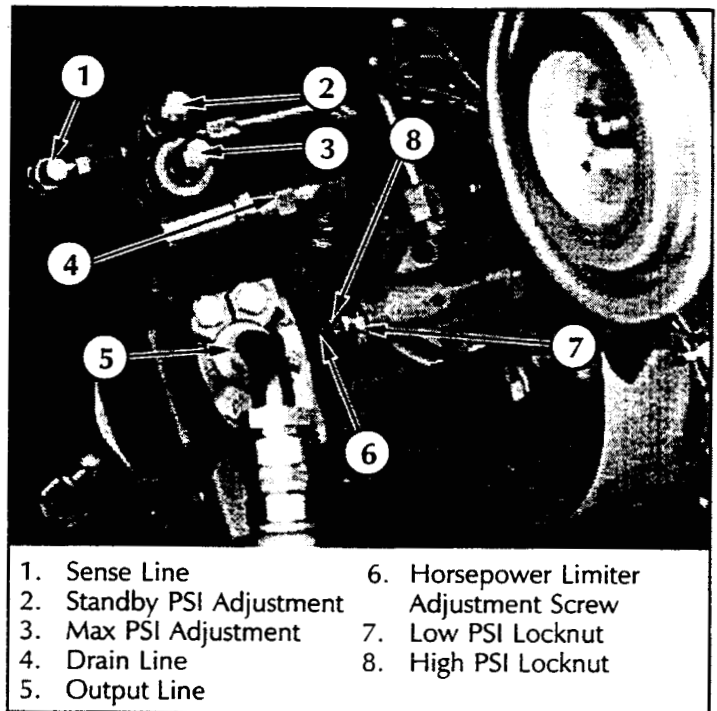

Figure 4-4: Hydraulic Pump

### LIFT RELIEF VALVE

1. Operate the hydraulic system 10 - 15 minutes to warm the oil.
2. Remove the cap or loosen the locknut on the Lift Relief Valve.
3. Turn the Lift Relief Valve adjustment screw counterclockwise two full turns.
4. Place rated load on the platform (Refer to specifications, page 1-2)
5. Depress the Throttle Button, and the Raise Button to lift the platform.
6. Slowly turn the Lift Relief Valve adjustment screw clockwise until the platform begins to rise.

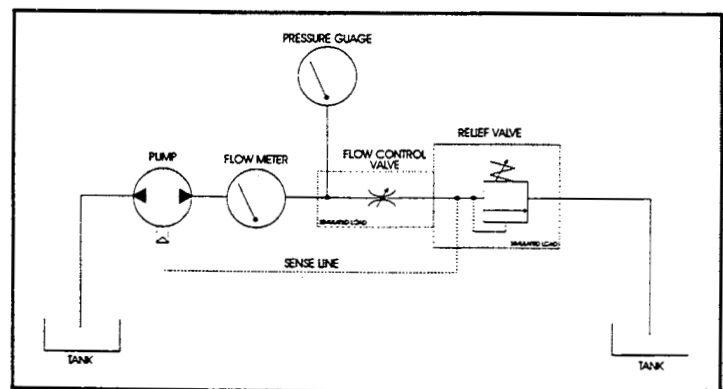

Figure 4-5: Flow Meter Set-Up

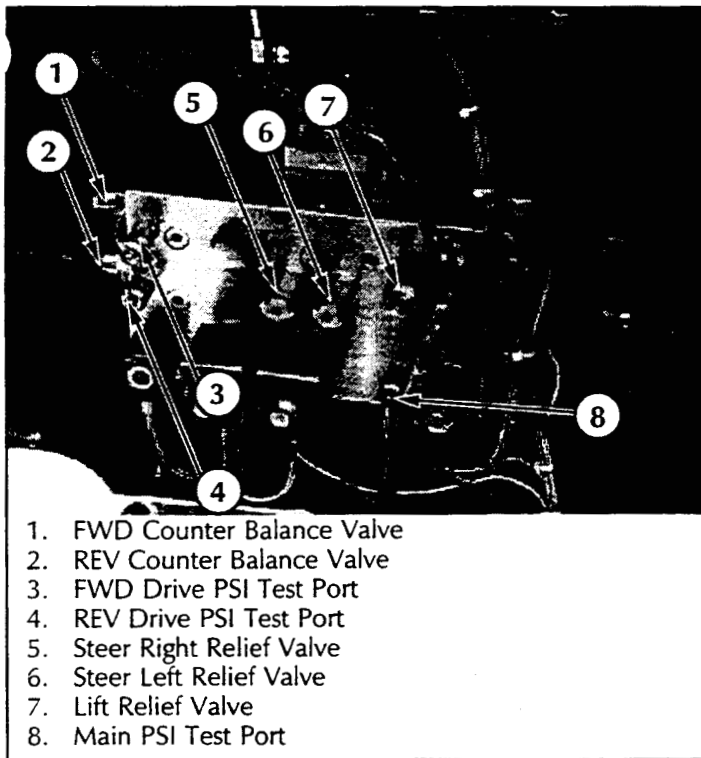

Figure 4-6: Valve Manifold

7. Replace the cap, or tighten the locknut on the Lift Relief Valve, and remove the load from the platform.

## COUNTERBALANCE VALVES

1. Operate the hydraulic system 10 to 15 minutes to warm the oil.
2. Elevate the Front (4WD only), and Rear Wheels to allow them to spin freely, and place on jackstands suitable to support the weight of the machine.
3. Remove the Green/White wire from terminal 17 in the Control Panel Assembly.
4. Install a 0-1000 P.S.I. pressure gauge at the Forward Drive Pressure Test Port.
5. Loosen the locknut on the **Reverse** Counterbalance Valve, push the control handle **FORWARD**, and adjust the valve until the gauge reads 800 P.S.I. (CW to decrease P.S.I., CCW to increase P.S.I.) Tighten the locknut.
6. Install a 0-1000 P.S.I. pressure gauge at the Reverse Drive Pressure Test Port.
7. Loosen the locknut on the **Forward** Counterbalance Valve, push the control handle **REVERSE**, and adjust the valve until the gauge reads 800 P.S.I. (CW to decrease P.S.I., CCW to increase P.S.I.) Tighten the locknut.
8. Recheck the pressures and adjust as necessary.

9. Remove the gauge and replace the cap. Replace the Green/White wire to terminal 17. Lower the machine off of the jackstands.

## STEERING RELIEF VALVES

1. Operate the hydraulic system 10 to 15 minutes to warm the oil.
2. Install a 0-3000 P.S.I. gauge at the Main Pressure Test Port.
3. Loosen the locknut or remove the cap on the Left Steer Relief Valve.
4. Turn the adjustment screw two full turns counter-clockwise.
5. Press the Steering Switch to the left and hold until the system bypasses.
6. Turn the Steering Relief Valve adjustment screw clockwise until the gauge reads 1500 P.S.I.
7. Tighten locknut or replace cap on Left Steering Relief Valve.
8. Repeat process for Right Steering Relief Valve

## BIDIRECTIONAL RELIEF VALVES

**Note: Check or reset Drive Motor Relief Valves only if you suspect that one of the Rear Wheels is not turning due to premature bypass. This condition is rare and Bidirectional Relief Valves should not be reset as part of normal maintenance.**

1. Operate the hydraulic system 10-15 minutes to warm the oil.
2. Remove the cap and install a 0-3000 P.S.I. pressure gauge at the Main Pressure Test Port.
3. Remove the Bidirectional Relief Valve from under the rear drive motor and exchange with the Lift Relief Valve.
4. Remove the cap from the Bidirectional Relief Valve and turn the adjustment screw two full turns counter-clockwise.
5. Depress the Throttle Button and the Raise Button to lift the platform to full height and hold until system bypasses.
6. Turn the adjustment screw clockwise until the pressure reaches 3000 P.S.I.
7. Replace the cap and return the Bidirectional Relief Valve and the Lift Relief Valve to their original positions.
8. Repeat as necessary for the other Bidirectional Relief Valve.
9. Remove the gauge and replace the Test Port Cap.

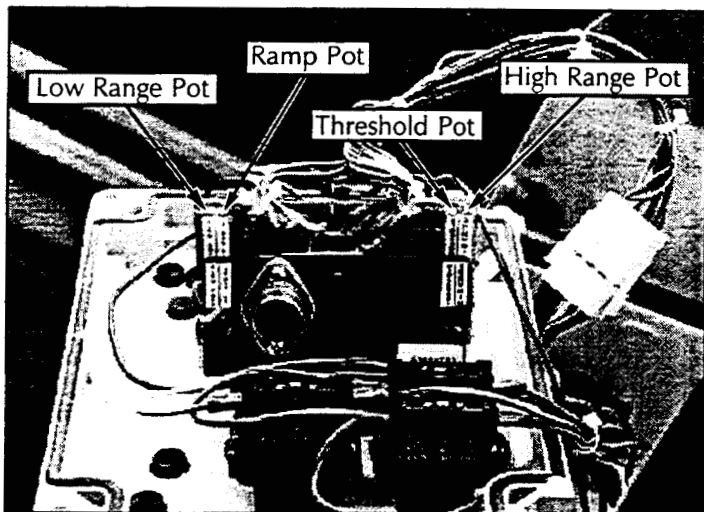

Figure 4-7: Proportional Controller

## 4.6 Switch Adjustments

### PROPORTIONAL CONTROL ADJUSTMENT

When required by the following procedure, lay out a twenty foot course, on level ground, free from potholes or other obstructions. Mark a starting line and finish line visible from the platform of the machine.

Potentiometers are sealed to protect sensitive adjustments from vibrations, or from tampering. Remove sealant prior to adjustment, and replace after.

Use a small screwdriver or special adjustment tool to set adjustment pots. Pots can be easily damaged.

Pots have 15 turns of adjustment, more than one turn will often be required to complete the adjustment. If pots have been previously set, reset by turning no more than 1 turn at a time. If they have not been previously set, preset to about mid range and start from there.

Turn pot clockwise (CW) to increase settings.

Turn pot counterclockwise (CCW) to decrease settings.

Adjust pots only in sequence as outlined in this procedure.

### Procedure

1. Lower machine fully to insure that controller is in high speed range.
2. Turn Ramp Trimpot fully counterclockwise until a click is heard with each revolution.
3. Push Control Handle slightly forward, just enough to illuminate the red L.E.D. on the P.C.B.
4. Adjust the Threshold Trimpot so that the machine just begins to move.
5. Push the Control Handle fully forward and drive the machine over the 20 foot course.

**Note:** Do not steer the wheels during speed test, insure that the front wheels are straight prior to this operation. Allow the machine to rise to full speed, and mark time from second that the Front Wheels cross the starting line, until the second that the Front Wheels cross the finish line.

6. Adjust the Hi Trimpot to the proper high speed found in Table 5-1.
7. Elevate the platform enough to put the machine into low speed range.
8. Push the Control Handle fully forward and drive the machine over the 20 foot course.
9. Adjust the Lo Trimpot to the proper low speed found in Table 5-1.
10. Lower the machine fully and turn the Ramp Trimpot 8 to 10 turns clockwise. Adjust for smooth acceleration.
11. Recheck speeds to insure proper adjustment. Reset as necessary.

### PLATFORM DOWN LIMIT SWITCHES

The Platform Down Switches close the circuit to the Cutout Relay, (R15), bypassing the Tilt Sensor when the platform is lowered; and to the Platform Down Relay, (R16), which provides power to the Drive Relay, Proportional Controller high speed circuit, and Series/Parallel Relay (R5).

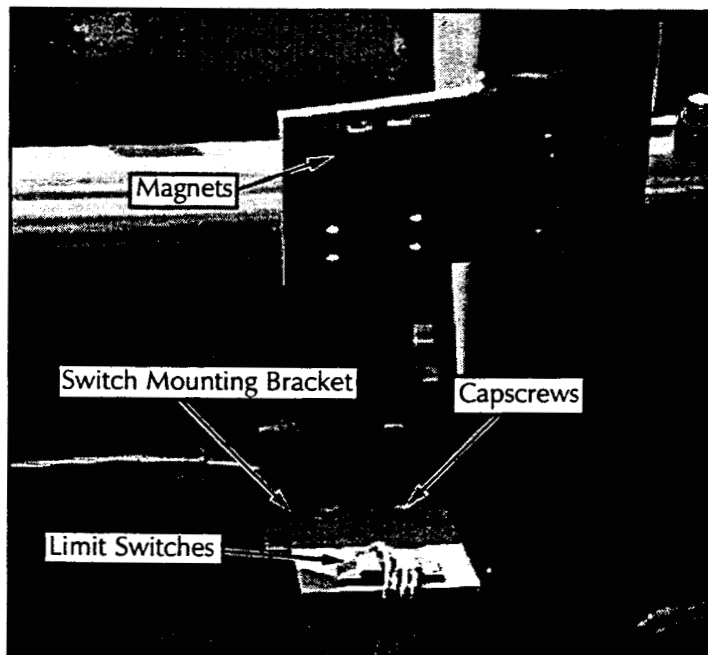

Figure 4-8: Platform Down Limit Switch

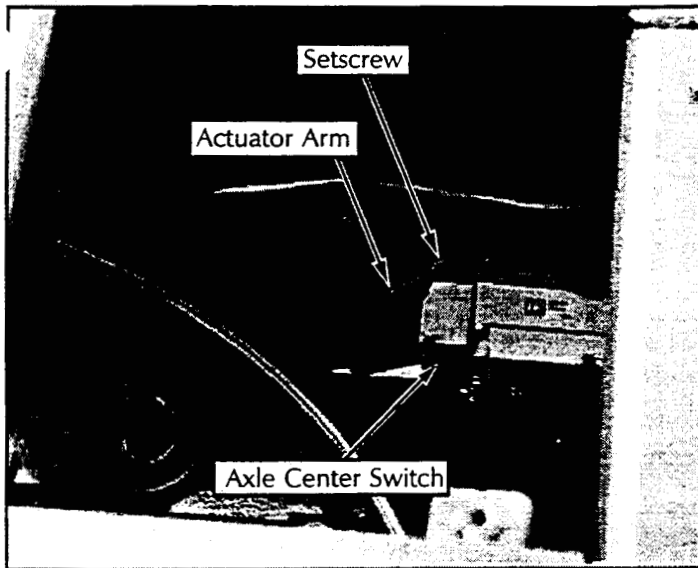

Figure 4-9: Axle Center Switch

## ⚠ WARNING ⚠

DO NOT attempt to adjust Limit Switches without first blocking the elevating assembly (see section 4.2).

1. Lower the Platform completely.
2. With the Platform / Chassis switch on Chassis, push the Tilt Sensor base to test the alarm circuit.
3. If the alarm sounds, elevate the Platform and adjust the position of the switch mounting bracket by loosening the capscrews and nuts holding the bracket in place and moving the bracket until the switches align with the magnets. Lower the Platform and retest. When switches are aligned, alarm will not sound while platform is lowered.
4. With platform elevated, repeat step 2. When switches are properly adjusted, alarm will sound.

## AXLE CENTER SWITCH

1. Place the work platform on a level surface with the front and rear axles parallel (on the same plane). Verify this using an inclinometer.
2. Loosen the setscrew on the lever of the limit switch. It should immediately spring to center. Tighten the setscrew.
3. Test the switch function by moving the machine to a location where the front axle will articulate off of center and raising the platform until the magnetic switches open (about 10 feet [3m]). The work platform should not drive. Retest with the axle off center in the other direction.

## TILT SENSOR

The Tilt Sensor has three wires; red-power (12v in), black-ground, white-output (12v out). To verify the sensor is working properly there are two LED's under the sensor; green indicates the sensor is on (has power), red indicates the sensor is level and the white wire is 'hot' (12v out).

1. Check tires for proper pressure.
2. Place machine on firm level surface  $\pm 1/4^\circ$ .
3. Use Inclinometer to ensure that the front and rear of the Chassis are level within  $\pm 1/4^\circ$ .
4. Adjust the three leveling locknuts until the bubble is centered in the circle on the attached bubble level.
5. Elevate the platform until the magnetic switches open (about 10 feet [3m]) and push the tilt sensor base to test the alarm circuit. Alarm should sound.

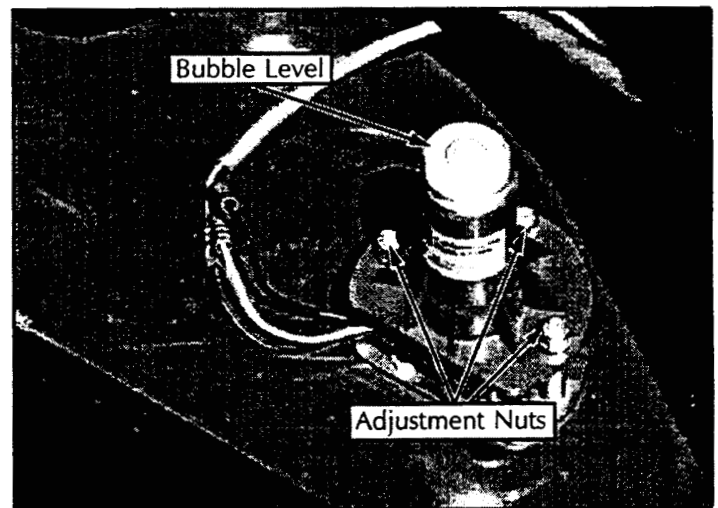

Figure 4-10: Tilt Sensor

## 4.7 Hydraulic Manifold

Though it is not necessary to remove the manifold to perform all maintenance procedures, a determination should be made prior to beginning as to whether or not the manifold should be removed before maintenance procedures begin.

### REMOVAL

1. Disconnect the battery ground cable.
2. Tag and disconnect the solenoid valve leads from the terminal strip.
3. Tag, disconnect and plug hydraulic hoses.
4. Remove the bolts that hold the manifold to the mounting bracket.
5. Remove manifold block.

### DISASSEMBLY

**NOTE: Mark all components as they are removed so as not to confuse their location during assembly. Refer to Figure 4-11 often to aid in disassembly and assembly.**

1. Remove coils from solenoid valves.
2. Remove spool valve cover and spool valve.
3. Remove solenoid valves, lift relief valve, counterbalance valves and divider combiner valve.
4. Remove fittings, plugs, springs, balls and orifices.

### CLEANING AND INSPECTION

1. Wash the manifold in cleaning solvent to remove built up contaminants and then blow out all passages with clean compressed air.
2. Inspect the manifold for cracks, thread damage and scoring where O-rings seal against internal and external surfaces.
3. Wash and dry each component and check for thread damage, torn or cracked O-rings and proper operation.
4. Replace parts and O-rings found unserviceable.

### ASSEMBLY

**NOTE: Lubricate all O-rings before installation to prevent damage to O-rings. Seat all balls in manifold block by lightly tapping on the ball with a brass drift punch.**

1. Install fittings, plugs, springs, balls and orifices. Use one drop of Loctite #242 on each screw-in orifice.
2. Install solenoid valves, lift relief valve, counterbalance valves, divider combiner valve, and spool valve.
3. Install coils on solenoid valves.

### INSTALLATION

1. Attach manifold assembly to mounting plate with bolts.
2. Connect Solenoid leads to terminal strip (as previously tagged).
3. Connect hydraulic hoses. Be certain to tighten hoses to manifold.
4. Operate each hydraulic function and check for proper operation and leaks.
5. Adjust lift relief, steering relief, and counterbalance valve pressures according to instructions in Section 4.5.

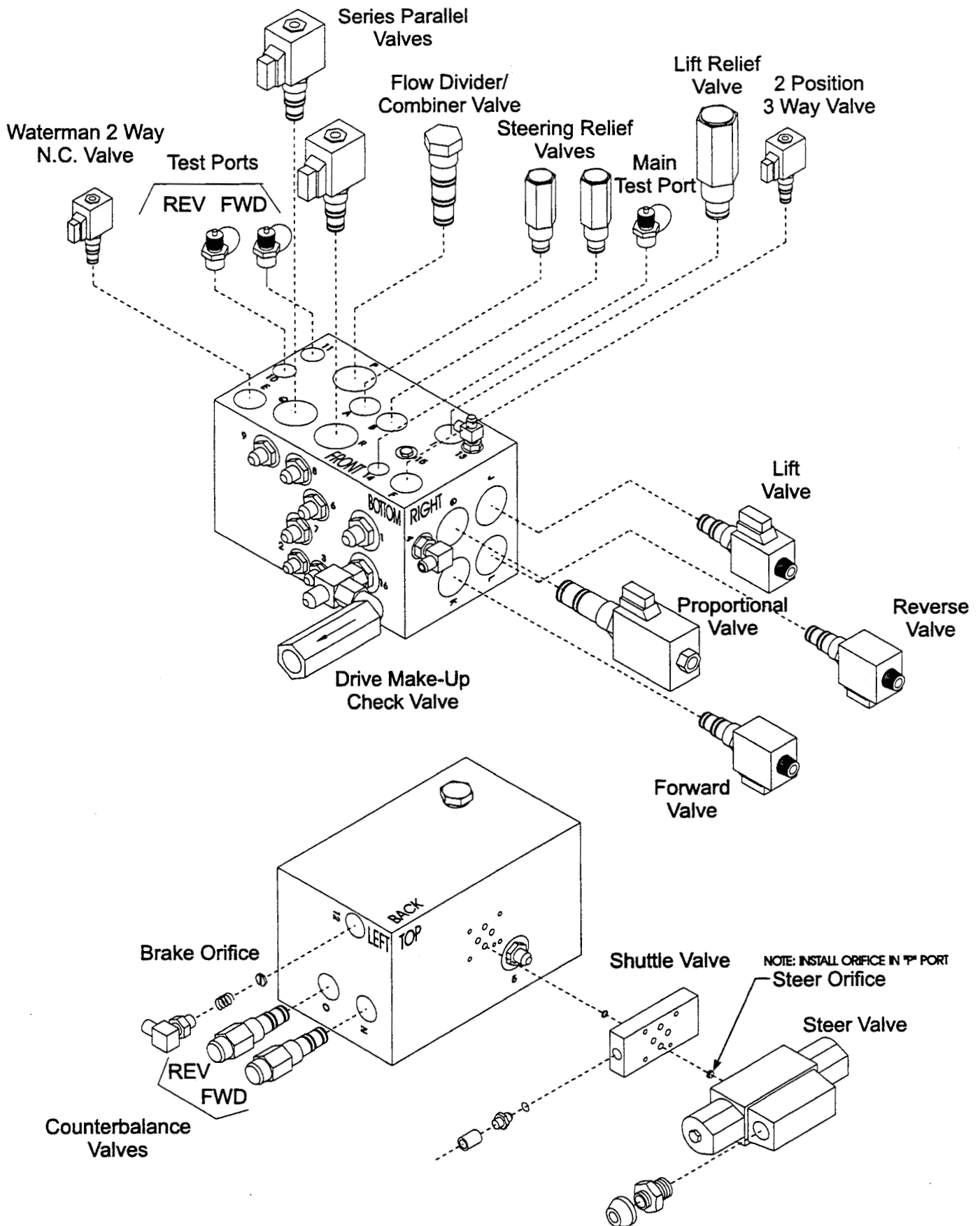

Figure 4-11: Hydraulic Manifold, Exploded View (4WD Shown)



## 4.8 Hydraulic Pump

**NOTE:** If the hydraulic tank has not been drained, suitable means for plugging the hoses should be provided to prevent excessive fluid loss.

### REMOVAL

1. Mark, disconnect and plug the hose assemblies.
2. Loosen the capscrews and remove the pump assembly from the engine.

### INSTALLATION

1. Torque each capscrew a little at a time until both capscrews are torqued to 20 ft. lbs. (27 N-m).
2. Unplug and reconnect the hydraulic hoses.
3. Fill the pump completely with clean hydraulic oil by pouring it into the drain line cavity.
4. Check the oil level in the hydraulic tank before operating the work platform.
5. Set standby and maximum pressures, and horsepower limiter nodes as outlined under *Pump Setup* in section 4.5 setting hydraulic pressures.

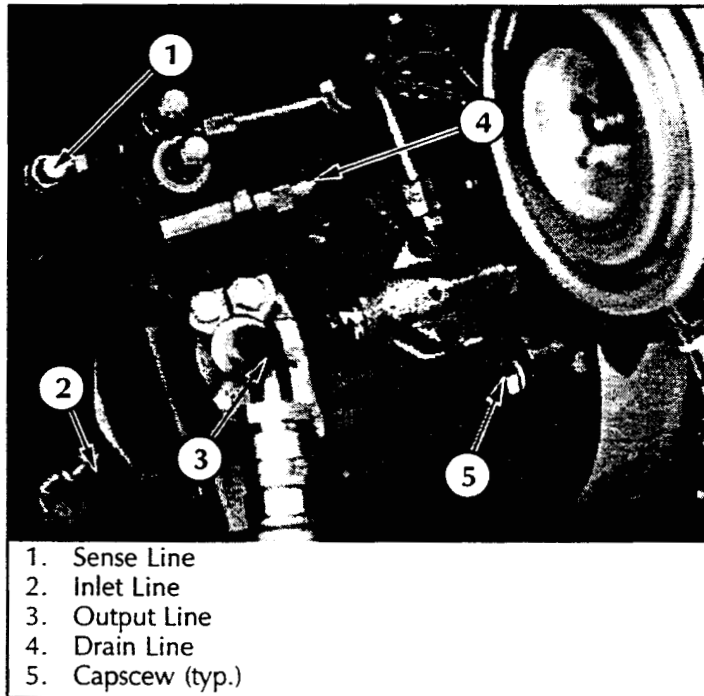

Figure 4-12: Hydraulic Pump

## 4.9 Hydraulic Brakes, Drive Motors, And Hubs

### REAR AXLE

#### Removal

1. Park the work platform on firm level ground and block the wheels to prevent the work platform from rolling.
2. Loosen the wheel nuts on the torque hub to be removed.
3. Raise the rear of the work platform using a 2-ton jack.
4. Position 2 1-ton jack stands under the rear axle to prevent the work platform from falling if the jack fails.
5. Remove the wheel lug bolts and wheel.
6. Tag and disconnect the hose assemblies from the drive motor and brake.

### CAUTION

Clean all fittings before disconnecting the hose assemblies.

Plug all port holes and hose assemblies IMMEDIATELY to prevent contamination from dust and debris.

**Note:** when disassembling, retain gaskets between components, they may be reused if undamaged.

7. Remove the four capscrews holding the motor to the brake. Remove the motor.
8. Remove the two socket head through bolts connecting the brake and the torque hub. Remove the brake.
9. Remove the eight capscrews connecting the torque hub to the rear axle. Remove the torque hub.

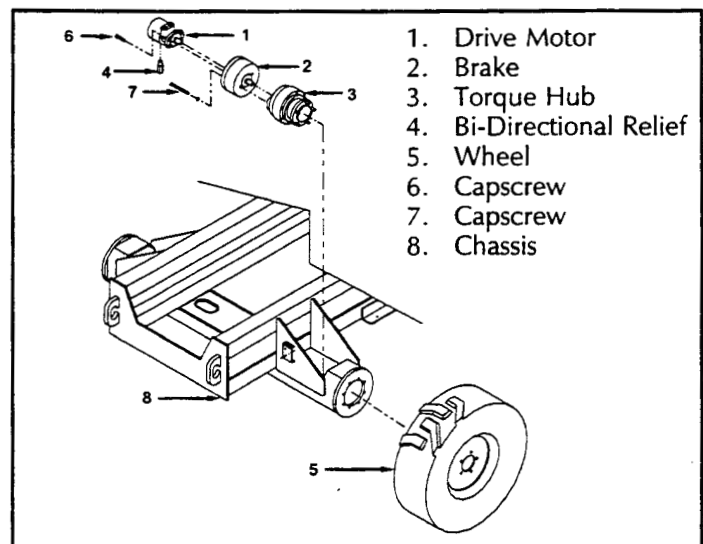

Figure 4-13: Rear Axle Assembly

## Installation

1. Install the torque hub to the rear axle. Align the holes and install the eight capscrews, tighten.
2. Coat the output shaft of the brake with high pressure molybdenum grease and install brake into torque hub. Align holes and install the two socket head through bolts, tighten.
3. Coat the output shaft of the drive motor with high pressure molybdenum grease and install into brake. Align holes and install the four capscrews, tighten.
4. Reinstall the hose assemblies to the drive motor and brake.
5. Reinstall the wheel and wheel nuts onto the torque hub. Torque the wheel nuts to 150 ft. lbs. (203 N-m).
6. Remove the jack stands used to block the wheels. Lower the jack and remove.
7. Operate the drive system to check for leaks. If the brake was serviced, bleed out the air using the bleed valve located on the brake housing.
4. Remove the piston (13) from the power plate (20) by introducing low pressure air (15 psi) into the hydraulic inlet. Make sure the piston is pointed away from anyone.
5. Remove o-rings (15 & 17) and backup rings (14 & 16) from the inner and outer diameter grooves of the piston, discard.
6. Clean the piston (13) and power plate (20) assemblies with solvent. Inspect the sealing surfaces of the piston (13) and power plate (20). Inspect the seal grooves in the piston. Replace these parts if they are damaged or scratched deeply. Lubricate piston (13), power plate (20), and seals (14, 15, 16, & 17) with clean hydraulic oil prior to assembly.
7. Install the backup rings (14 & 16) and o-rings (15 & 17) into the seal grooves in the piston.
8. Install the piston into the power plate using a shop press. Be careful not to damage the seals during assembly. Center the cutouts in the piston with the torque pin holes in the power plate. Press the piston to a depth no less than flush, but not exceeding 0.120 in. below the surface of the power plate at the cutouts in the piston. This depth is critical, the brake will not hold if it is exceeded.

## Seal Replacement, Brake

1. With shaft protrusion downward remove the capscrews (22) from the brake assembly.
2. Remove the power plate (20) from the housing (1).
3. Remove the gasket (2), discard.
9. Install gasket (2).
10. Install power plate / piston assembly (13 & 20) to housing (1) using capscrews (22). Tighten sequentially, one turn at a time, to press the two assemblies together. Torque capscrews 50 to 60 ft.-lbs.

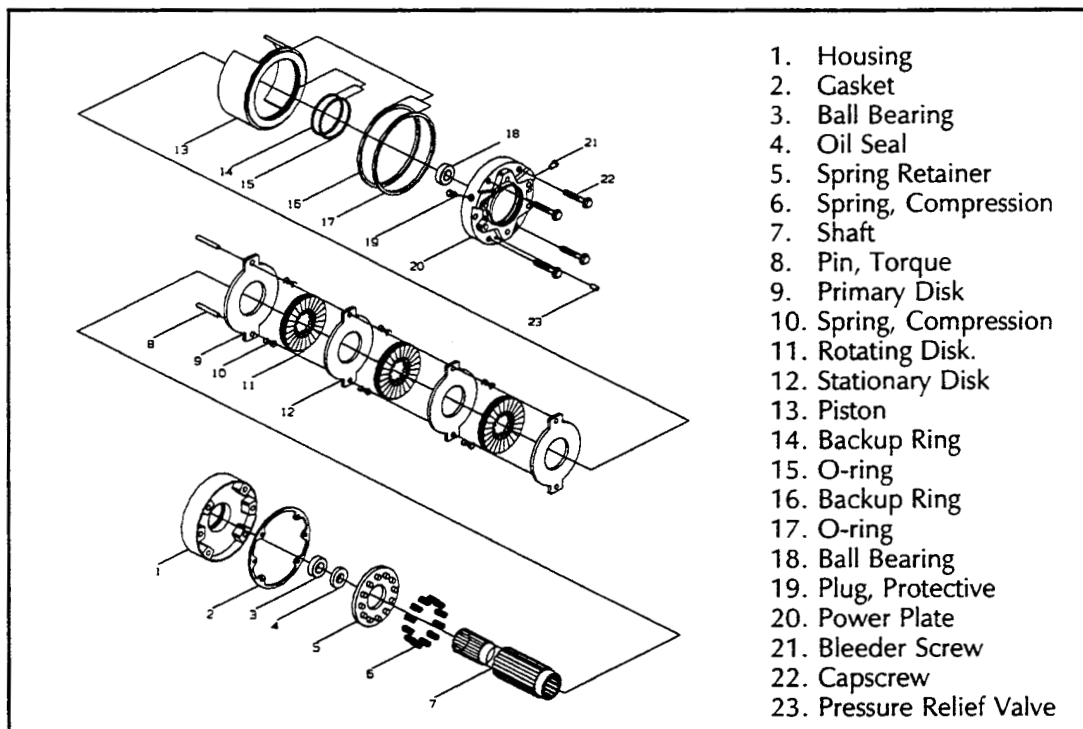

1. Housing
2. Gasket
3. Ball Bearing
4. Oil Seal
5. Spring Retainer
6. Spring, Compression
7. Shaft
8. Pin, Torque
9. Primary Disk
10. Spring, Compression
11. Rotating Disk.
12. Stationary Disk
13. Piston
14. Backup Ring
15. O-ring
16. Backup Ring
17. O-ring
18. Ball Bearing
19. Plug, Protective
20. Power Plate
21. Bleeder Screw
22. Capscrew
23. Pressure Relief Valve

Figure 4-14: Brake Assembly

## *Seal Replacement, Rear Motor*

1. Remove all shaft related components from shaft (27) (i.e. Keys, wire rings, nuts). To aid in reassembly of the motor, make a "v" shaped set of lines from the end cover (24) to the housing using either paint or a marker. With shaft facing down, secure motor in vise by clamping on to housing (15).
2. Loosen and remove seven bolts (26) holding motor assembly together. Remove end cover (24) and body seal (10). Discard seal. Remove balance plate (22) taking care not to drop the four steel balls (23) located in the four holes in the balance plate (22). Remove rotor assembly (21), manifold boot (19), manifold (18), drive link spacer (20) (note: some motors do not use spacer), drive link (17) and thrust bearing (13). Remove body seals (9) from rotor assembly (21) and housing seal (8) from housing (15) and discard seals. (note: compare old housing seal (8) to the two housing seals included in kit to determine which one to use.)
3. Gently tap shaft (27) upward from housing (15) and remove through rear of housing and lay aside. Remove housing (15) from vise and turn over. Pry dust seal (1) from housing. Push the seal carrier (11), thrust washer (12) and thrust bearing (13) down until they make contact with the roller bearing (14) located in the housing bore.
4. Remove wire ring (2), steel backup shim (3) and high pressure seal (4) from inner bore groove with a small screwdriver (note: compare old high pressure seal (8) to the two high pressure seals included in kit to determine which one to use.). Lift out seal carrier (11), thrust washer (12) and thrust bearing (13) from the housing bore. Using a small screwdriver, carefully pry shaft seal (7), teflon backup seal (6) and metal backup shim (5) from seal carrier (11) and discard. Lay seal carrier (11), thrust washer (12) and thrust bearing (13) aside. (note: if a new thrust washer (12) and seal carrier (11) is included in kit, old items may be discarded).
5. At this point, all parts should be cleaned in an oil-based solvent and dried using compressed air (for safety, observe all OSHA safety guidelines). All new seals should be lightly coated in clean oil prior to installation.
6. Place shaft (27) on a clean flat surface with output end facing up. Place thrust bearing (13) then thrust washer (12) on shaft. Lightly coat seal area of shaft with clean oil and place plastic installation sleeve with shaft seal (7) down onto shaft covering all splines, keyways and wire ring grooves. Slide shaft seal (7) down onto shaft (27) making sure that lip on seal faces down (see figure 1 for correct seal orientation) until it contacts thrust washer (12). Remove plastic installation sleeve. Carefully install the teflon backup seal (6) onto the shaft (27) with the flat side up and the seal lip facing the shaft seal (7). Place the metal backup shim (5) onto the shaft and against the teflon backup seal (6). Place the seal carrier (11) onto the shaft (large end down) and carefully press the seal carrier (11) down onto the seal assembly using an arbor press and sleeve to compress the seals into the carrier.
7. With pilot side facing up, place housing (15) on spacers to raise housing approximately .250 above work surface (note: spacers should allow shaft to contact work surface). Place shaft/seal carrier assembly into housing (15). Install high pressure seal (4) into groove in housing. Install metal backup shim (3) against high pressure seal (4) in groove in housing bore by squeezing the shim (3) between thumb and forefinger to bow shim. While maintaining bow in shim, start the shim into the groove and use a small screwdriver to push the shim into groove. Install wire ring (2) into the groove making sure that the ends are butted.
8. While holding shaft into housing, place housing/shaft assembly in vise with shaft end down. Making sure that end of drive link (17) with crowned splines goes into shaft end, install drive link (17) into shaft and tap lightly to seat the seal carrier assembly against the wire ring (2). Place thrust bearing (13) over drive link (17). If seal carrier (27) is properly seated against wire ring (2), thrust bearing (13) will be flush with rear surface of housing.
9. Install housing seal (8) into groove in housing (15). Place manifold (18) onto housing (15) with side with only seven holes facing housing (15). Install manifold boot (19) over manifold (18) and align bolt holes. Place body seals (9) in grooves in both sides of rotor (21). Place rotor (21) onto manifold (18) with side of rotor with chamfer in splines facing manifold (18).
10. Install balance plate (22) onto rotor (21) making sure side with holes for steel balls (23) faces up. Install four steel balls (23) in holes in balance plate (22). Install end cover seal (10) into groove in end cover (24) and place end cover onto balance plate (22). Install seven assembly bolts (26) and pre-torque to 10 ft.lbs. Using the bolt torque sequence shown in figure 2, final torque all bolts to 50 ft.lbs.
11. Remove motor from vise and place on work surface with shaft (27) facing up. Making sure that lip on seal (1) faces up, place dust seal (1) over shaft (27). Using a sleeve and a hammer, carefully drive dust seal (1) into place.

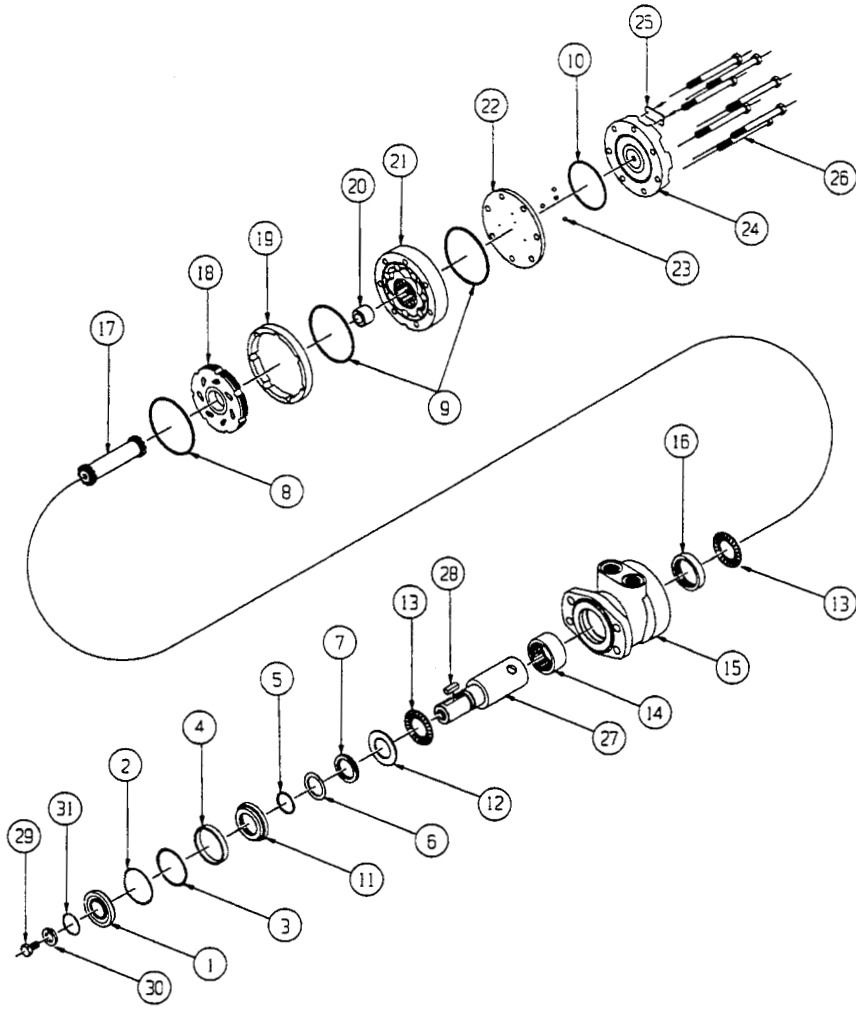

1. Dust Seal
2. Split Wire Ring
3. Metal Backup Shim
4. High Pressure Seal
5. Metal Backup Shim
6. Teflon Backup Seal
7. Shaft Seal
8. Housing Seal
9. Body Seals (2)
10. End cover Seal
11. Seal Carrier
12. Thrust Washer
13. Thrust Bearing (2)
14. Front Housing Bearing
15. Housing
16. Rear Housing Bearing
17. Drive Link
18. Manifold
19. Manifold Boot
20. Drive Link Spacer
21. Rotor Assembly
22. Balance Plate
23. Steel Balls (4)
24. End cover
25. I.D. Tag Assembly
26. Assembly Bolts (7)
27. Shaft
28. Shaft Key
29. Shaft Bolt
30. Lock Washer
31. Wire Ring

WIRE RING    HIGH PRESSURE SEAL    METAL BACKUP SHIM    SHAFT SEAL

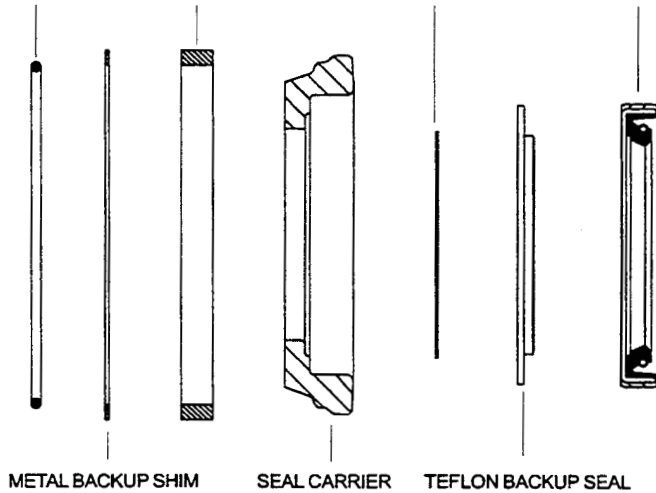

**Detail: Shaft Seal Assembly**

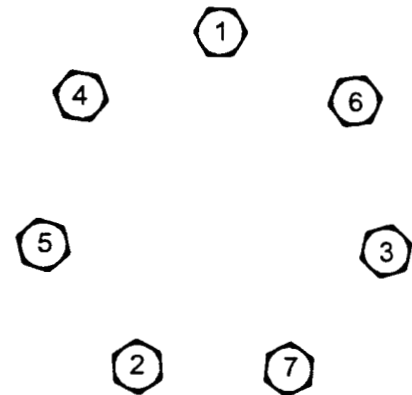

**Detail: Bolt Tightening Sequence**

**Figure 4-15: Rear Drive Motor Assembly**

**FRONT AXLE 4WD****Removal**

1. Park the work platform on firm level ground and block the wheels to prevent the work platform from rolling.
2. Loosen the wheel lug nuts on the motor to be removed.
3. Raise the front of the work platform using a 2-ton jack.
4. Position two 1-ton jack stands under the front axle to prevent the work platform from falling if the jack fails.
5. Remove the wheel nuts and wheel.

**CAUTION**

Clean all fittings before disconnecting the hose assemblies.

Plug all port holes and hose assemblies IMMEDIATELY to prevent contamination from dust and debris.

6. Tag and disconnect the hose assemblies.
7. Remove the screw and nut from the end of the steering link. Swing the connecting link clear of the steering link.
8. Remove the 'E' ring from the steering link pin.
9. Lift the connecting link off of the steering link pin.
10. Swing the trunnion assembly around to gain access to the inside.
11. Remove the four nuts from inside the trunnion and remove the drive motor/hub assembly.

**Installation**

1. Position the drive motor/hub assembly into the steering trunnion and secure with the four nuts, tighten.
2. Install the connecting link onto the steering link pin and secure with the 'E' ring.
3. Swing the connecting link toward the steering link, and align the holes. Install the screw and nut, tighten.
3. Install the hose assemblies.
4. Install the wheel and wheel nuts onto the hub. Torque the wheel nuts to 150 ft. lbs. (203 N-m).
5. Remove the jack stands used to block the wheels. Lower the jack and remove.
6. Operate the drive system to check for leaks.

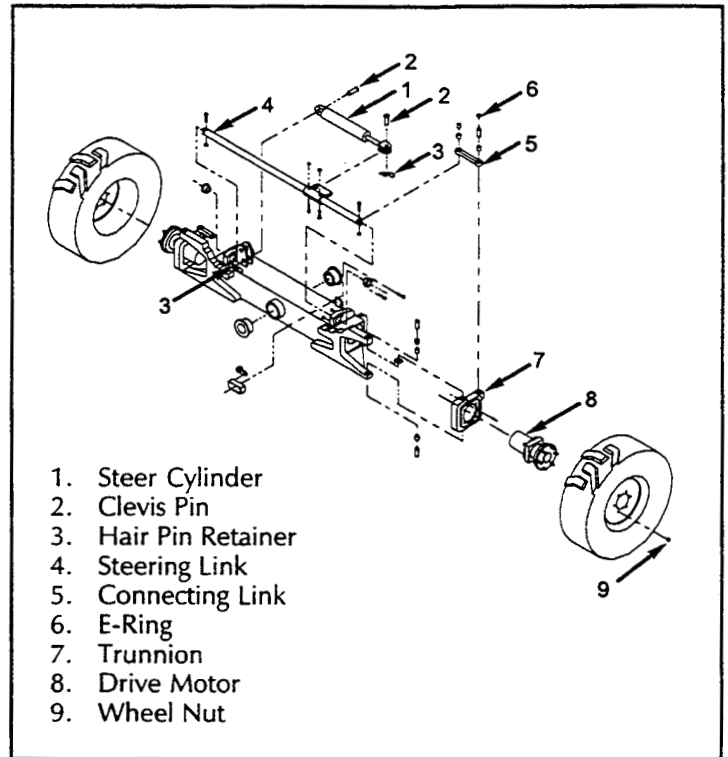

**Figure 4-16: Front Axle Assembly 4WD**

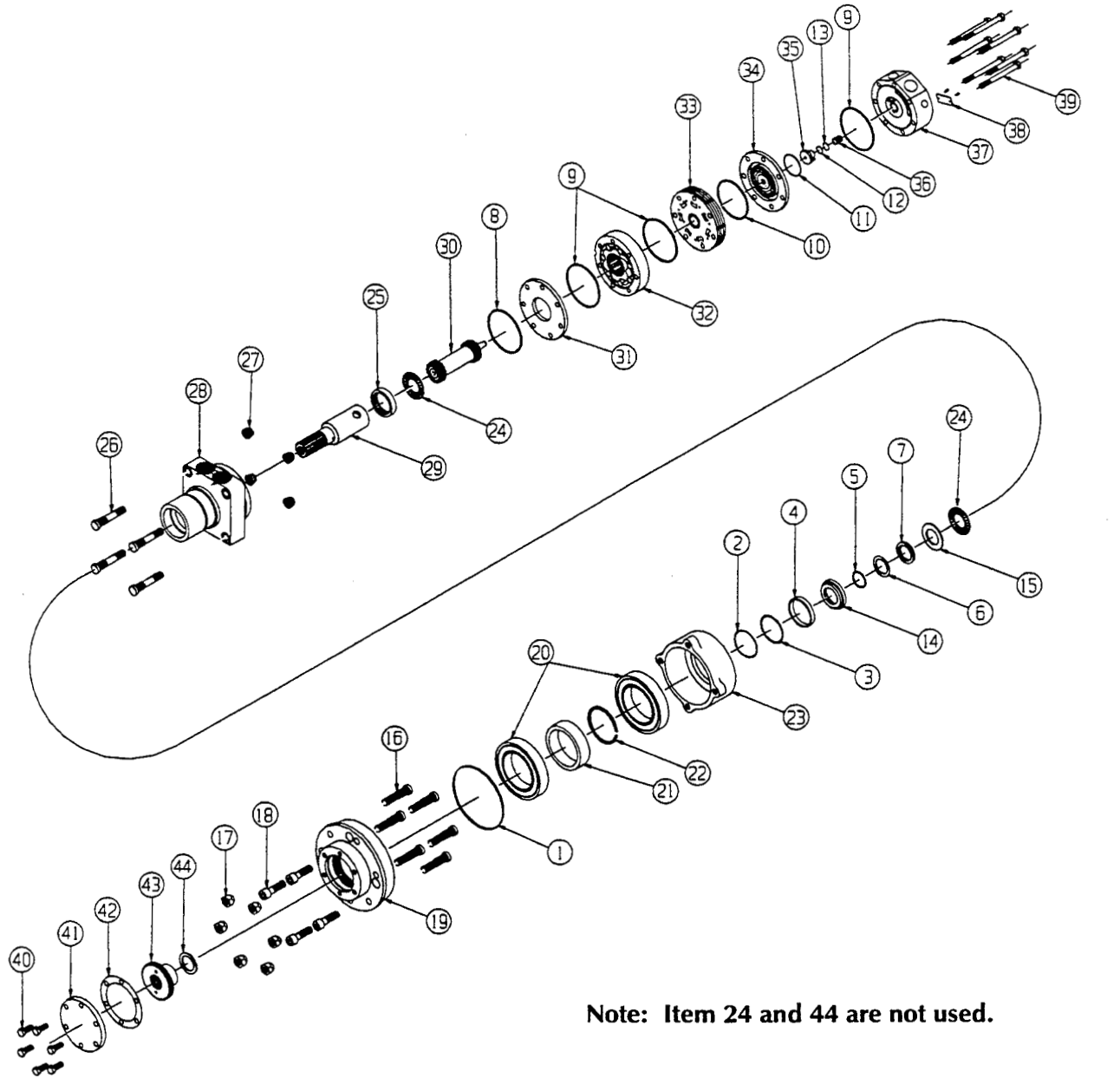

Note: Item 24 and 44 are not used.

- |                       |                        |                               |                             |
|-----------------------|------------------------|-------------------------------|-----------------------------|
| 1. Flange Seal        | 12. O-Ring Seal        | 23. Bearing Hub               | 34. Commutator Assembly     |
| 2. Wire Ring          | 13. Teflon Backup Seal | 24. Thrust Bearings           | 35. End cover Piston        |
| 3. Metal Backup Shim  | 14. Seal Carrier       | 25. Rear Housing Bearing      | 36. Piston Spring           |
| 4. High Pressure Seal | 15. Thrust Washer      | 26. Planetary Mount Studs (4) | 37. End cover               |
| 5. Metal Backup Shim  | 16. Studs (6)          | 27. Mounting Nuts (4)         | 38. I.D. Tag Assembly       |
| 6. Teflon Backup Seal | 17. Lug Nuts (6)       | 28. Housing                   | 39. Assembly Bolts (7)      |
| 7. Shaft Seal         | 18. Capscrews (4)      | 29. Shaft                     | 40. Driver Cover Screws (6) |
| 8. Housing Seal       | 19. Wheel Flange       | 30. Drive Link                | 41. Driver Cover            |
| 9. Body Seals (3)     | 20. 125mm Bearings (2) | 31. Divider Plate             | 42. Paper Gasket            |
| 10. Manifold Seal     | 21. Bearing Spacer     | 32. Rotor Assembly            | 43. Driver                  |
| 11. Commutator Seal   | 22. Thrust Ring        | 33. Manifold                  |                             |

Figure 4-17: Front Drive Motor Assembly

### Seal Replacement, Front Motor (Figure 4-17,18)

1. Remove six bolts (40) from end cap (41). Lift end cap (41) off of wheel flange (19). Peel or scrape paper gasket (42) off of end cap and/or wheel flange (19). If grease is between end cap (41) and driver (43), remove grease. Screw a 1/4-20 bolt (not included) into one of the two threaded holes in the driver (43) and lift the driver out of the wheel flange (19). If grease is between driver (43) and housing pilot (28), remove grease.
2. To aid in reassembly of the motor, make a "v" shaped set of lines from the end cover (37) to the housing (28) using either paint or a marker. With hub facing down, secure motor in vise by clamping on to housing (28). Loosen and remove seven bolts (39) holding motor assembly together. Remove end cover (37) carefully as piston (35) and spring (36) may fall out. If piston does not come out, carefully pry piston (35) out of end cover (37) and lay aside. Remove o-ring seal (12) and teflon backup seal (13) from end cover and discard seals. Remove spring (36) and lay aside.
3. Lift commutator container and commutator (34) from motor and lay aside. Place commutator on a flat, clean surface with the seal (11) facing up. Place the tip of a small screwdriver on the seal (11) and gently tap until opposite side of seal lifts from groove. Remove seal and discard.
4. Remove manifold (33), rotor set (32) and divider plate (31) from motor. Remove all seals (8, 9, & 10) from components and discard. (caution- do not allow rolls to drop from rotor assembly (32) when removing rotor assembly from motor.) Remove drive link (30) from motor and lay aside.
5. Remove motor from vise and re-clamp in vise with pilot side of housing facing up. Using a brass hammer, carefully tap shaft (29) down until rear shaft bearing (25) is protruding from rear housing surface approximately 5/8". Using a small screwdriver, remove wire ring (2), metal backup shim (3) and high pressure seal (4) from inner bore groove. Remove shaft/seal carrier assembly (29, 14, 5-7) up through housing. Remove seal carrier (14), thrust washer (15) and thrust bearing (24) from shaft and lay aside.
6. Using a small, flat bladed screwdriver, carefully pry shaft seal (7), teflon backup seal (6) and metal backup shim (5) from seal carrier (14) and lay aside. Lay seal carrier (14), thrust washer (15) and thrust bearing (24) aside.
7. At this point, all parts should be cleaned in an oil-based solvent and dried using compressed air (for safety, observe all OSHA safety guidelines). All new seals should be lightly coated in clean oil prior to installation.
8. (note: shaft seals for 1-1/4" and 1-1/2" shafts are included in this kit. To determine which new seal to use for servicing, refer to old shaft seal). Place shaft on a clean surface with output end facing up. Install thrust bearing (24) and then thrust washer (15) onto shaft. After coating shaft seal (7) and teflon backup seal (6) with clean oil, install shaft seal (7) onto shaft with lip facing. Install teflon backup seal (6) with lip facing down followed by metal backup shim (5) (see figure 1 for correct seal position). Install seal carrier (14) onto shaft with large end facing down. Using a sleeve and press, gently press seal carrier (14) down to compress seal assembly (5-7) into seal carrier (14).
9. Place housing (28) in vise with pilot of housing facing up. Place spacer under housing (28) to prevent shaft (29) from dropping to work surface. Spacer should allow shaft to be about 1/2" below rear surface of housing.
10. Place shaft/shaft seal assembly into housing (28) with output end facing up. Install high pressure seal (4) into groove in inner bore of housing (28). Install metal backup shim (3) against high pressure seal (4) by squeezing the shim (3) between thumb and forefinger to bow shim. While maintaining bow in shim, start the shim into the groove and use a small screwdriver to push the shim into groove. Install wire ring (2) into groove making sure that the ends are butted.
11. While holding shaft into housing, secure housing/shaft assembly in vise with shaft end down. Gently tap shaft bearing (25) down into housing until bearing is approximately 1/16" below rear housing surface. Install drive link (30) into shaft and gently tap drive link (30) down to seat seal carrier (14) against wire ring (2). If shaft (29) is seated properly against wire ring (2), rear surface of shaft (29) should be flush with rear surface of housing (28).
12. Install housing seal (8) into groove in housing (28). Place divider plate (31) onto housing (28) aligning bolt holes. Place body seals (9) in grooves in both sides of rotor (32). Place rotor (32) onto divider plate (31) with side of rotor with chamfer in splines facing divider plate (31). Place manifold (33) onto rotor (32) with seal groove side up. Install manifold seal (10).
13. Install the commutator seal (11) into the commutator (34) with the metal side facing up. Use finger pressure to press the seal down flush with the surface of the commutator. Place the commutator



container onto the manifold (33) and then place the commutator onto the protruding end of the drive link (30) making sure that the seal side faces up.

14. Install the remaining body seal (9) in the groove in the face of the end cover (37). Install piston spring (36) into end cover (37), then the white teflon backup seal (13) followed by the o-ring seal (12). Lining up the alignment pin with the hole in the end cover, press piston (35) into the end cover (37). While holding the piston (35) in the end cover (37), lower the end cover assembly onto the motor. Check to make sure that the end cover ports are in their original position.
15. Install the seven assembly bolts (39) and pre-torque to 10 ft. Lbs. Using bolt torque sequence shown in figure 2, final torque all bolts to 50 ft. Lbs.
16. Place spacer (44) over shaft (29) . Place driver (43) over shaft (29) while rotating wheel flange (19) slightly to allow splines to mate. Place paper gasket (42) onto wheel flange (19). Reapply grease between driver (43) and end cap (41) (only if end cap (41) does not have grease fitting). Place end cap (41) onto wheel flange (19). Install six bolts (40) and torque to 50 ft. Lbs. Using the bolt torque sequence shown if figure 3. If end cap (41) has grease fitting, apply grease.

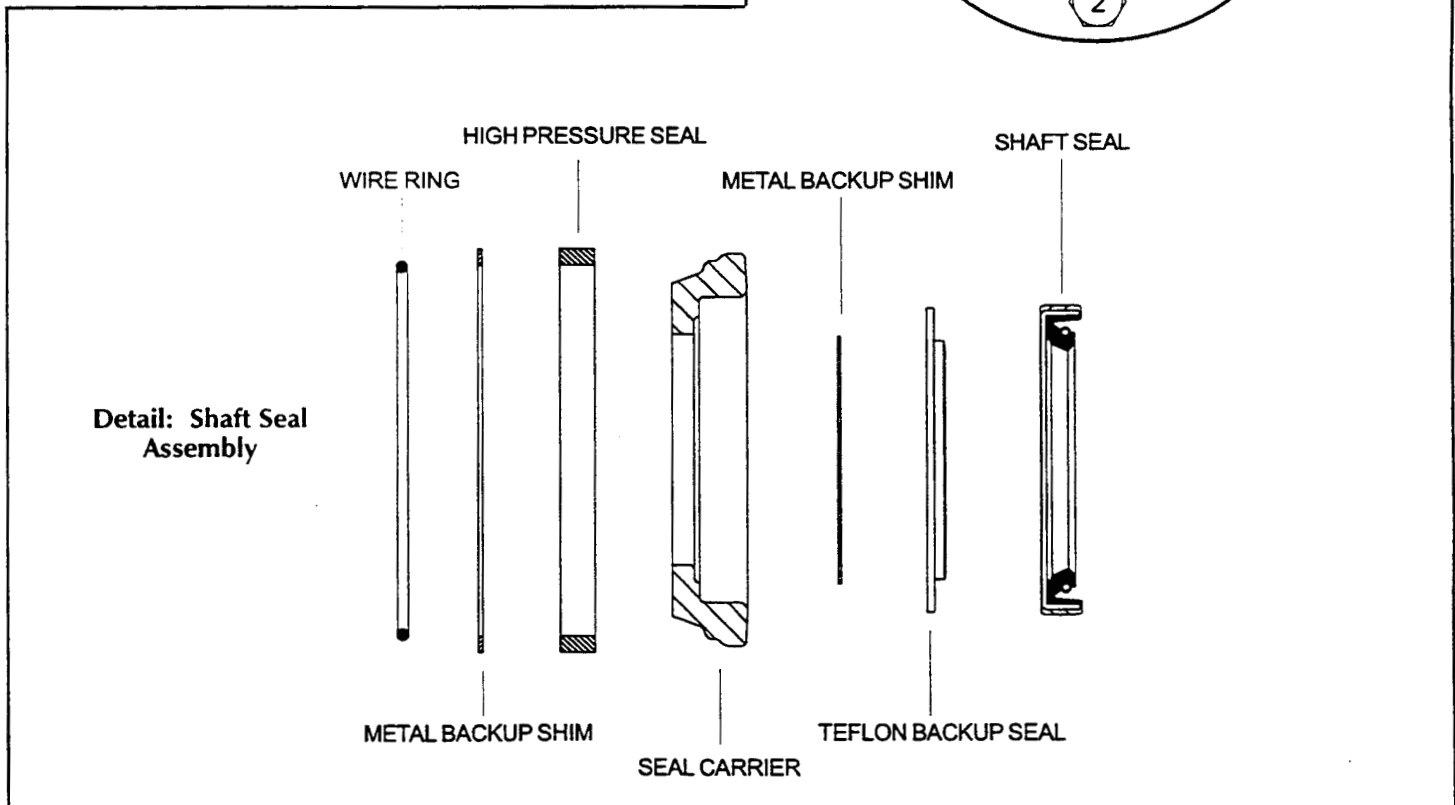
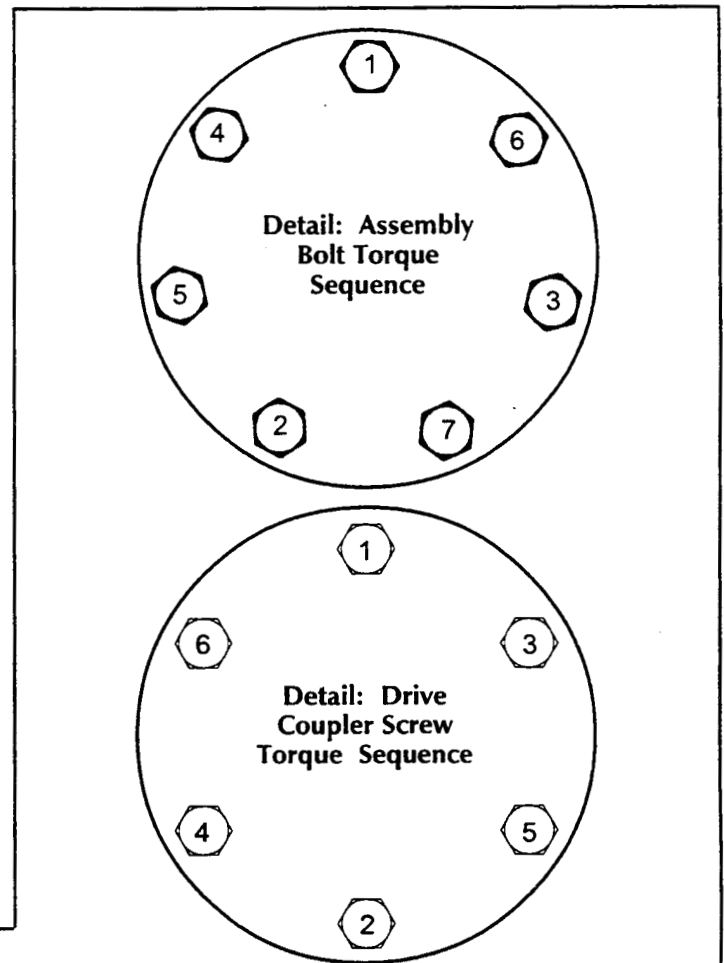

Figure 4-18: Front Drive Motor Assembly, Details

## 4.10 Axle Cylinder (4WD Only)

### REMOVAL

**Note:** Be sure platform is fully down and that machine is on level ground.

1. Lift the chassis with a 2 ton jack, and place 1 ton jackstands underneath the left and right frame members just behind the articulating axle assembly. Lower the jack. The weight of the front of the chassis should *now* be supported by the jackstands, and the front wheels should *still* be allowed to touch the ground.
2. Remove the four screws from the front axle cover, remove cover.
3. Remove and cap the hoses.
4. Remove the hex nuts from the cylinder pins at both ends, remove pins.
5. Remove the cylinder from of the chassis.

### SEAL REPLACEMENT

**Note:** Provide a clean work area for this operation, and observe clean assembly practices. Seals and hydraulic cylinder components are highly sensitive to contamination that may not even be visible to the naked eye.

1. Use a spanner wrench to unscrew the head from the cylinder body tube.
2. Carefully slide the rod, piston, and head out of the body tube and place on a clean surface.
3. Remove cotter pin from cylinder rod.
4. Unscrew the slotted nut from the rod end.
5. Remove the piston from the rod.
6. Slide the rod out of the head.
7. Remove all of the old seals and wear rings, discard.
8. Thoroughly clean all parts with solvent. Rinse the inside of the tube and allow to drain. A high pressure rinse and wipe with a lint free rag is preferable.
9. Inspect the rod, head, piston, and tube for scratches, pits, or polishing. Check seal groves and sealing surfaces. Scratches or pits deep enough to catch the fingernail are unacceptable, replace the affected component. Polishing is a sign of uneven loading, when this occurs, the surface should be checked for roundness. Surfaces not round within .007" should be replaced.
10. Lubricate all components and seals with clean hydraulic oil prior to assembly.

**Note:** During seal replacement steps, do not use sharp edged tools to avoid cutting the seals. After assembling all seals, allow at least one hour for the seals to elastically restore to their original shape before assembly. Refer to Figure 4-16 for component identification and placement.

11. Separate the three components of the piston seal. Stretch the rubber inner ring over the piston and into the seal groove. Warm the teflon outer ring to 150°F using heated hydraulic fluid or water. Stretch the teflon outer ring into the seal groove. Clean the groove in the teflon ring and install the quad ring. Verify that none of the rings have twisted.
12. Install the glass filled nylon wear rings into the outer grooves in the piston.
13. Twist the U-Cup seal into a 'C' shape and allow it to snap into the groove in the head.
14. Use the above technique to install the wiper into the head.
15. Install the static o-ring and the static backup ring into the groove in the head. Verify that the backup ring is closest to the threads.
16. Install the sealing o-ring between the threads and the flange lip on the head, be careful not to damage the o-ring on the threads.
17. Slide the head assembly onto the rod.
18. Install the static o-ring into the groove on the rod.
19. Install the piston onto the rod.
20. Install the slotted nut and torque to 325 to 520 ft.-lbs. Install the cotter pin. Do not back off on the slotted nut to install the cotter pin. Once the torque has reached 325 ft.-lbs., increase until the next slot aligns with the hole in the rod.
21. Slide the piston, rod, and head into the tube. Be careful not to damage the piston seal on the threads during assembly. If necessary, use shimstock to protect the piston seal when inserting.
22. Use a spanner wrench to tighten the head.

### INSTALLATION

1. Remove the pilot operated check valves and completely fill both ends of cylinder with hydraulic oil. Replace the pilot operated check valves.
2. Attach both ends of the cylinder to the upper and lower attachments with cylinder pins.
3. Install the hex nuts onto the cylinder pins, tighten.
4. Remove the jackstands from under the chassis.
5. Operate the work platform over rough terrain and check for proper function and leaks.

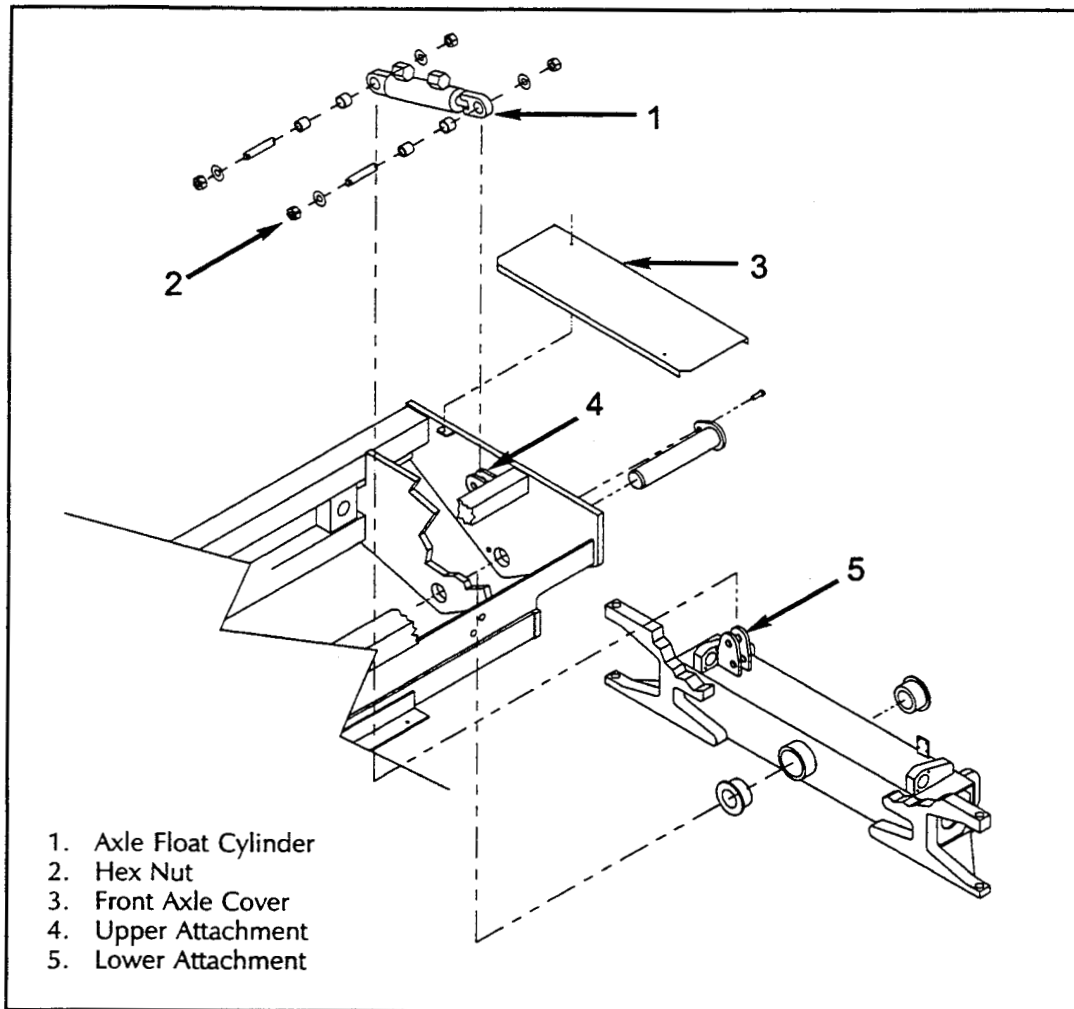

- 1. Axle Float Cylinder
- 2. Hex Nut
- 3. Front Axle Cover
- 4. Upper Attachment
- 5. Lower Attachment

Figure 4-19: Floating Axle Assembly

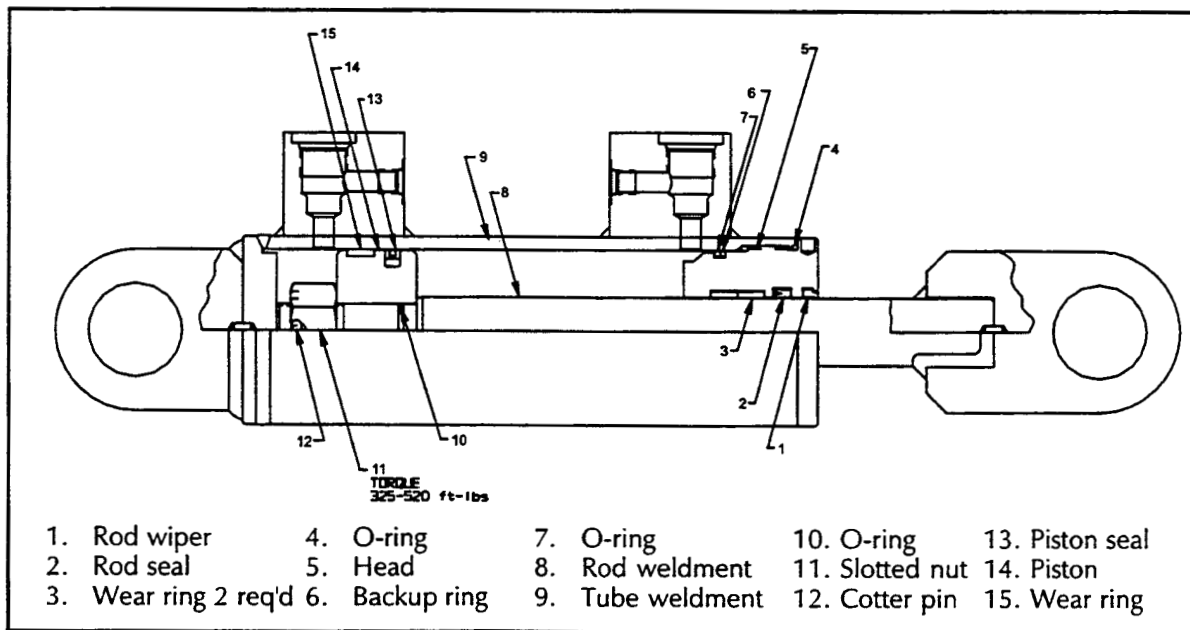

- |                      |                |                  |                 |                 |
|----------------------|----------------|------------------|-----------------|-----------------|
| 1. Rod wiper         | 4. O-ring      | 7. O-ring        | 10. O-ring      | 13. Piston seal |
| 2. Rod seal          | 5. Head        | 8. Rod weldment  | 11. Slotted nut | 14. Piston      |
| 3. Wear ring 2 req'd | 6. Backup ring | 9. Tube weldment | 12. Cotter pin  | 15. Wear ring   |

Figure 4-20: Axle Float Cylinder Cross Section

## 4.11 Steering Cylinder

### REMOVAL

1. Remove the two capscrews holding the front axle cover in place (4WD only).
2. Remove and cap the hoses. Mark them for reference.
3. Remove the hair pin retainers from the clevis pins at each end of the cylinder.
4. Remove the clevis pins.
5. Remove the cylinder from the chassis.

### SEAL REPLACEMENT

**Note: Provide a clean work area for this operation, and observe clean assembly practices. Seals and hydraulic cylinder components are highly sensitive to contamination that may not even be visible to the naked eye.**

1. Use a spanner wrench to rotate the head until the retaining ring becomes visible in the groove milled into the side of the cylinder. Insert a screwdriver under the beveled edge of the retaining ring to start it through the opening. Continue to rotate the head until the retaining ring works its way out of the opening.
2. Remove the rod, head, and piston from the tube.
3. Unscrew the locknut from the end of the rod.
4. Remove the piston from the rod.
5. Slide the rod out of the head.
6. Remove all of the old seals and wear rings, discard.
7. Thoroughly clean all parts with solvent. Rinse the inside of the tube and allow to drain. A high pressure rinse and wipe with a lint free rag is preferable.
8. Inspect the rod, head, piston, and tube for scratches, pits, or polishing. Check seal grooves and sealing surfaces. Scratches or pits deep enough to catch the fingernail are unacceptable, replace the affected component. Polishing is a sign of uneven loading, when this occurs, the surface should be checked for roundness. Surfaces not round within .007" should be replaced.
9. Lubricate all components and seals with clean hydraulic oil prior to assembly.

**Note: During seal replacement steps, do not use sharp edged tools to avoid cutting the seals. After assembling all seals, allow at least one hour for the seals to elastically restore to their original shape before assembly. Refer to Figure 4-16 for component identification and placement.**

10. Stretch the o-ring loader into the seal groove on the piston. Verify that it has not been twisted or pinched. Start one edge of the bidirectional piston seal into the groove in the piston and work it around into the groove with your thumbs. Be very careful not to cut the outer diameter of this seal.
11. Install the wear ring into the groove on the piston.
12. Twist the u-cup seal into a 'C' shape and snap it into the groove inside of the head. Note that the 'U' groove in the seal should face the inside of the cylinder.
13. Use the above technique to install the wiper into the groove inside the head. Note that the blade of the wiper should face toward the outside of the cylinder.
14. Install the static backup ring into the groove closest to the inside edge of the head.
15. Install the static o-ring into the above groove, making sure that it falls inside of the static backup ring.
16. Slide the head onto the rod.
17. Install the static o-ring onto the end of the rod.
18. Install the piston onto the rod.
19. Install the locknut onto the rod, torque to 250 ft.-lbs.
20. Slide the piston, rod, and head into the tube. Be careful not to damage any of the seals during assembly. If necessary, use shimstock to prevent the seals from extruding into the retaining ring slot.
21. Using a spanner wrench, rotate the head until the retaining ring hole is visible in the groove milled into the side of the cylinder. Insert the retaining ring hook into the hole and rotate the head 1-1/4 turns until the retaining ring is drawn completely into the tube and the ends are covered.

### INSTALLATION

1. Align the ends of the cylinder with the mounts on the chassis.
2. Install the clevis pins.
3. Install the hair pin retainers into the clevis pins at each end of the cylinder.
4. Install the hoses, noting their orientation markings from disassembly.
5. Install the front axle cover and the two capscrews holding it in place, tighten (4WD only).

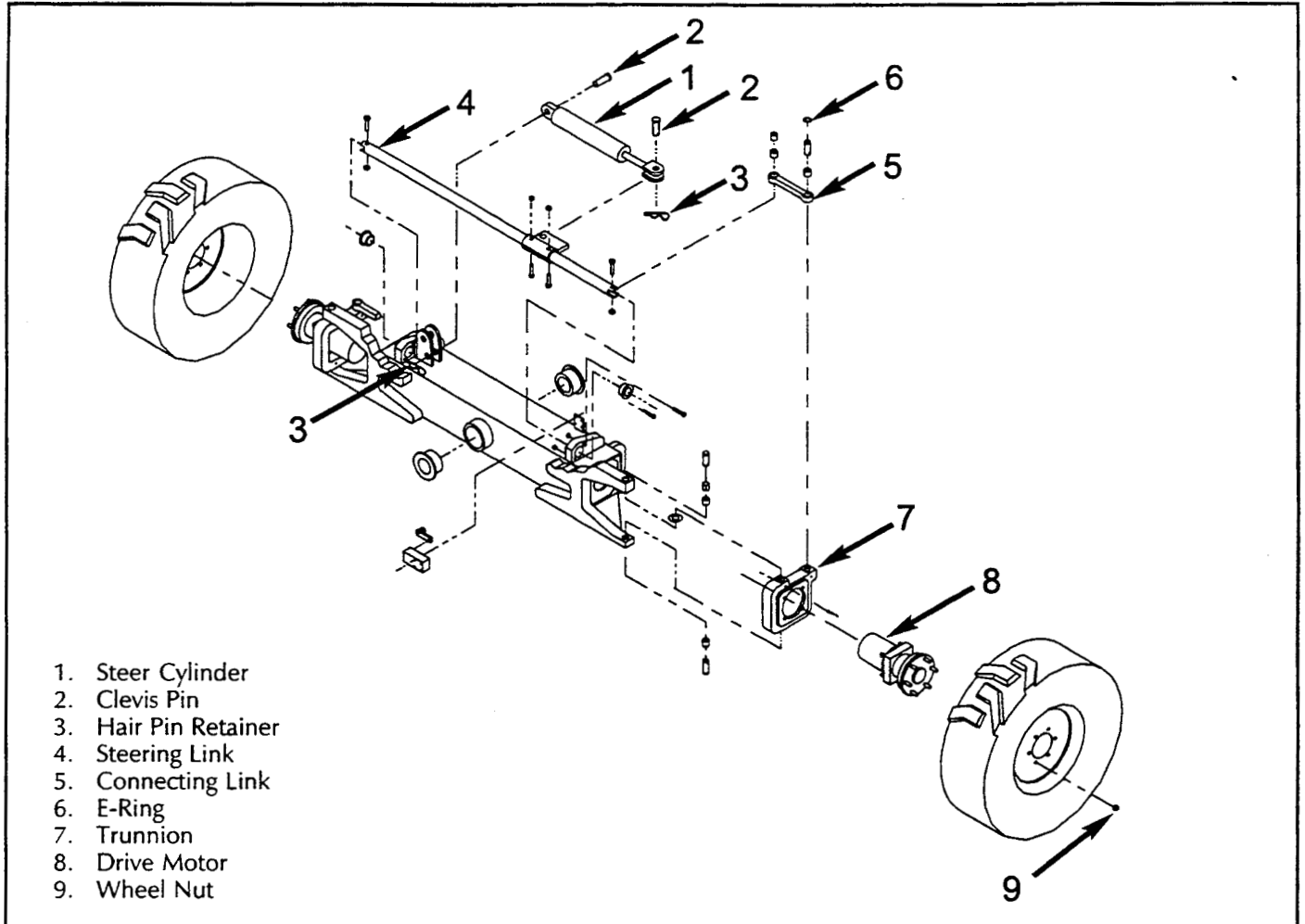

Figure 4-21: Front Axle Assembly 4WD

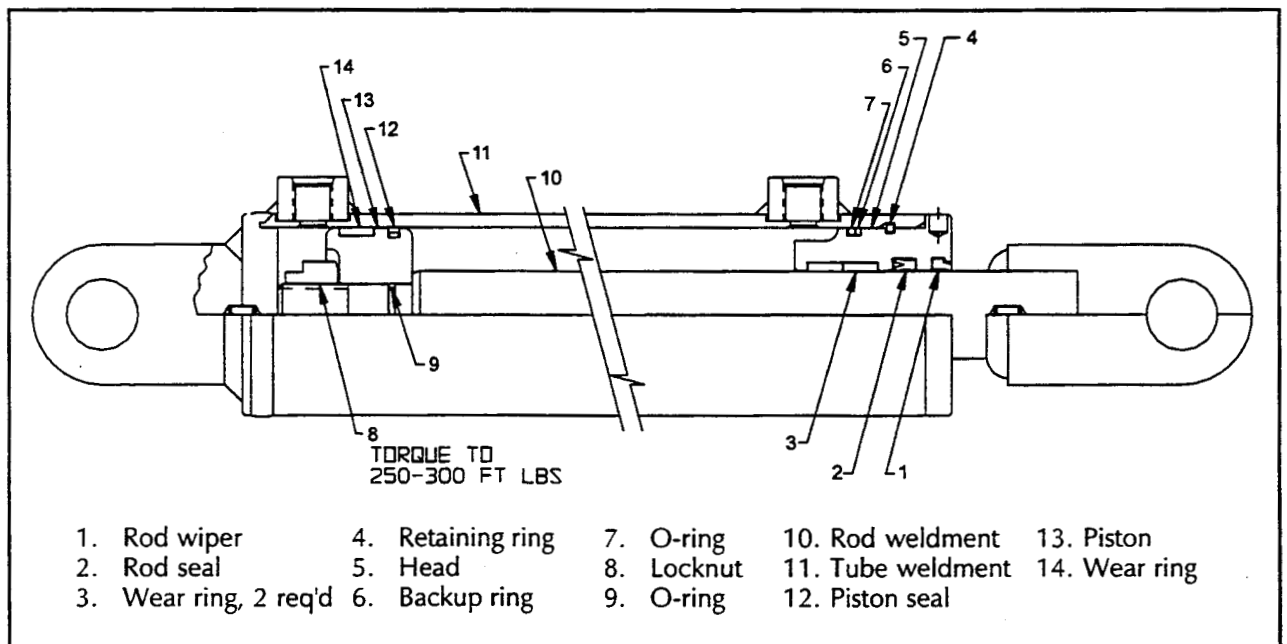

Figure 4-22: Steering Cylinder Cross Section

## 4.12 Lift Cylinder

### REMOVAL

1. Raise and block the elevating assembly (see section 4.3).
2. Open emergency lowering valve to be sure all pressure is out of the lift cylinder.
3. Remove and cap both hoses and fittings.
4. Remove the down valve and cable assembly.
5. Support the lift cylinder with a suitable lifting device to prevent falling.
6. Remove the retaining bolts from the upper and lower pivot pins.
7. Drive out the pivot pins, upper one first, then the lower one.
8. Hoist the cylinder out of the elevating assembly from the front. **DO NOT sling the cylinder by the rod end pivot, this will cause the cylinder to extend when hoisted.**

### SEAL REPLACEMENT

**Note: Provide a clean work area for this operation, and observe clean assembly practices. Seals and hydraulic cylinder components are highly sensitive to contamination that may not even be visible to the naked eye.**

1. Use a spanner wrench to unscrew the head from the cylinder body tube.
2. Carefully slide the rod, piston, and head out of the body tube and place on a clean surface.
4. Unscrew the locknut from the rod end.
5. Remove the piston from the rod.
6. Slide the head off of the rod.
7. Remove all of the old seals and wear rings, discard. **Do not remove the cast iron ring from the piston.**
8. Thoroughly clean all parts with solvent. Rinse the inside of the tube and allow to drain. A high pressure rinse and wipe with a lint free rag is preferable.
9. Inspect the rod, head, piston, and tube for scratches, pits, or polishing. Check seal grooves and sealing surfaces. Scratches or pits deep enough to catch the fingernail are unacceptable, replace the affected component. Polishing is a sign of uneven loading, when this occurs, the surface should be checked for roundness. Surfaces not round within .007" should be replaced.
10. Inspect and clean the cushion orifice if any debris is present.

11. Lubricate all components and seals with clean hydraulic oil prior to assembly.

**Note: During seal replacement steps, do not use sharp edged tools to avoid cutting the seals. After assembling all seals, allow at least one hour for the seals to elastically restore to their original shape before assembly. Refer to Figure 4-16 for component identification and placement.**

12. Separate the three components of the piston seal. Stretch the rubber inner ring over the piston and into the seal groove. Warm the teflon outer ring to 150°F using heated hydraulic fluid or water. Stretch the teflon outer ring into the seal groove. Clean the groove in the teflon ring and install the quad ring. Verify that none of the rings have twisted.
13. Install the glass filled nylon wear rings into the outer grooves in the piston.
14. Twist the u-cup seal into a 'C' shape and allow it to snap into the groove in the head.
15. Use the above technique to install the wiper into the head.
16. Install the static o-ring and the static backup ring into the groove in the head. Verify that the backup ring is closest to the threads.
17. Install the sealing o-ring between the threads and the flange lip on the head, be careful not to damage the o-ring on the threads.
18. Slide the head assembly onto the rod.
19. Install the static o-ring into the groove on the rod.
20. Install the piston onto the rod.
21. Install the locknut and torque to 1125 ft.-lbs.
22. Slide the piston, rod, and head into the tube. Be careful not to damage the piston seal on the threads during assembly. If necessary, use shimstock to protect the piston seal when inserting.
23. Use a spanner wrench to tighten the head.

## INSTALLATION

**NOTE:** Before installing the cylinder, check the pins and bearings for excessive wear. Replace if necessary.

1. Using a suitable lifting device, lower the cylinder into the elevating assembly from the front. **DO NOT sling the cylinder by the rod end pivot, this will cause the cylinder to extend when hoisted.**
2. Align the pivots and install the pivot pins, lower one first, then the upper one.
3. Install the retaining bolts into the pivot pins.
4. Install the down valve and cable assembly. Adjust the cable to stop on the collar of the cable jacket, before the down valve reaches the full extent of its pull. The down valve may leak if the cable is allowed to pull the spool of the valve beyond its limit.
5. Install the hoses.
6. Lift and lower the machine for several cycles to work out the air. Check for leaks, repair as necessary.

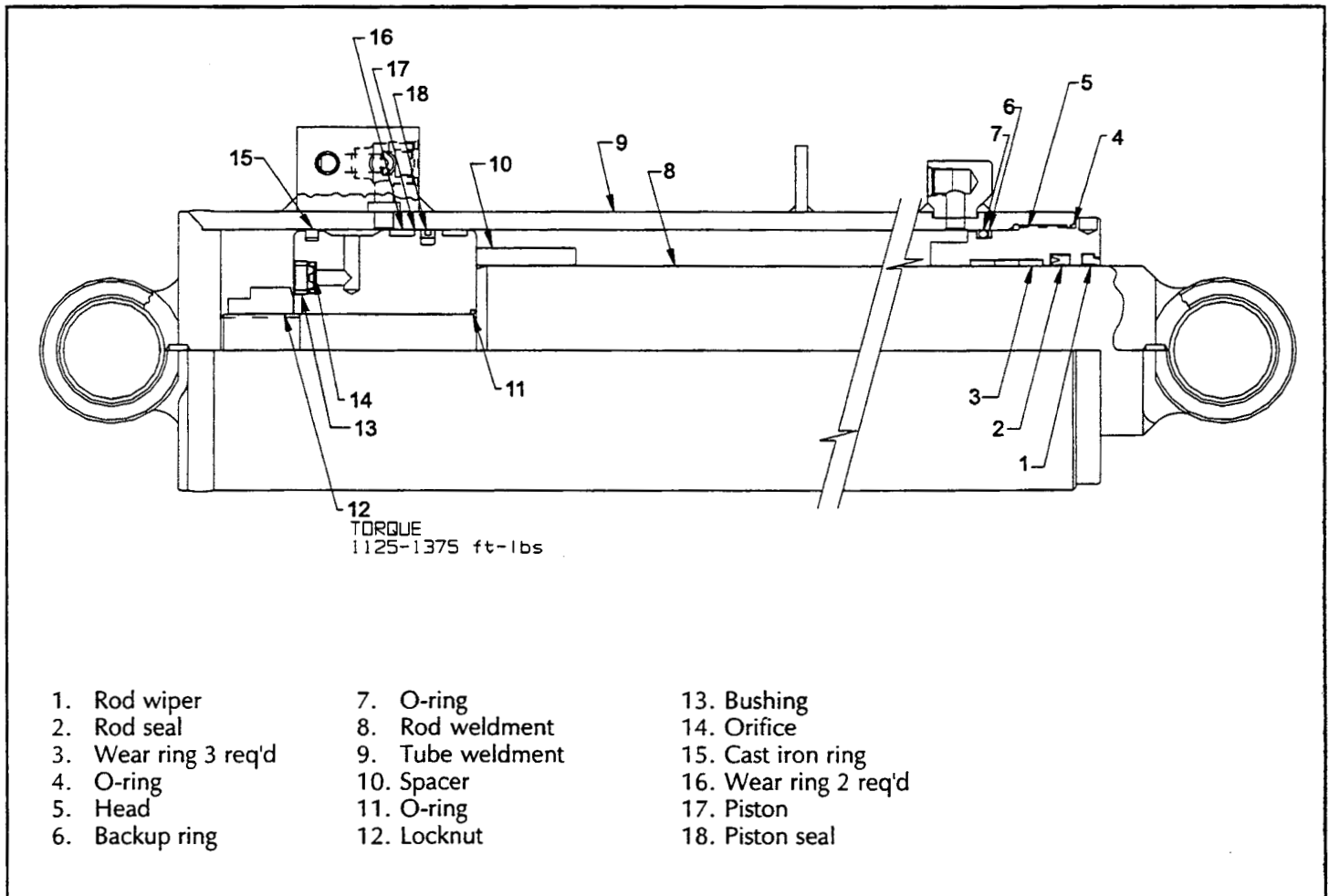

Figure 4-23 Lift Cylinder Cross Section



## 4-13 Outrigger Cylinder

### REMOVAL

1. Remove the plug from the top of the outrigger cylinder.
2. Disconnect the wires from the pressure switch and the ball switch. Tag them for identification during reassembly.
3. Unscrew the strain relief and pull the wires out of the top of the cylinder.
4. Remove and cap the hoses. Tag them for identification during reassembly.
5. Remove the four capscrews, nuts, and washers holding the outrigger cylinder to the outrigger support weldment.
6. Remove the outrigger cylinder.

### SEAL REPLACEMENT

**Note: Provide a clean work area for this operation, and observe clean assembly practices. Seals and hydraulic cylinder components are highly sensitive to contamination that may not even be visible to the naked eye.**

1. Clamp barrel assembly into vise, using aluminum sleeve to protect barrel from excessive scratches. Remove counterbalance valve from barrel assembly, use extreme caution valve is under pressure.
2. Unthread mount plate bolt from barrel assembly using a spanner wrench, a sharp impact on wrench is needed to loosen loctite from threads. Remove mount plate from end of rod.
3. Unthread retaining nut and remove from barrel assembly, using a spanner wrench.
4. Gently remove rod assembly from inside barrel assembly using extreme caution not to damage chrome plating on rod.
5. Remove seal retainer from rod assembly. Remove & discard all seals from seal retainer (rod wiper, rod seal, and static seal #1).
6. Clamp rod assembly in vise, using aluminum sleeve to protect chrome plating from damage. Drill out stakes on piston nut apply heat to threads on rod and piston, to loosen loctite on threads. Remove piston from rod assembly using spanner wrench.
7. Remove piston from rod, remove piston seal and discard.
8. Clean all components with cleaning solvent. Clean all loctite from foot pad bolt.

9. Apply a light coating of hydraulic oil to all seals and sealing components prior to assembly.

**Note: During seal replacement steps, do not use sharp edged tools to avoid cutting the seals. After assembling all seals, allow at least one hour for the seals to elastically restore to their original shape before assembly. Refer to Figure 4-26 for component identification and placement.**

10. Install rod wiper by folding into a 'C' shape and allowing it to "snap" into the outer seal groove in the seal retainer.
11. Install rod seal into inner seal groove in seal retainer using above method.
12. Stretch static seal #1 into outer seal groove on seal retainer.
13. Stretch piston seal into seal groove on piston.
14. Install seal retainer onto rod assembly, from piston end of rod, using a sharp blow to seal retainer, with hard rubber mallet, to overcome seal squeeze.
15. Apply Loctite® #262 (or equivalent) to rod end threads. Install piston onto rod end, torque using spanner wrench until tight.
16. Install rod assembly into barrel assembly, using extreme caution not to damage chrome plating on rod.
17. Seat seal retainer into barrel using a sharp blow with a hard rubber mallet to overcome seal squeeze.
18. Thread retaining nut onto barrel assembly, using spanner wrench, tighten.
19. Apply Loctite® #242 (or equivalent) to threads of foot pad bolt.
20. While holding foot pad in place at end of rod, install foot pad bolt using spanner wrench, tighten.

### INSTALLATION

1. Install the outrigger cylinder to the outrigger support weldment using the four capscrews, nuts, and washers; tighten.
2. Install the hoses exactly as disassembled.
3. Thread the wires for the pressure switch and the ball switch through the strain relief.
4. Reattach the wires to the switches exactly as disassembled.
5. Tighten strain relief.
6. Install plug to top of outrigger cylinder.

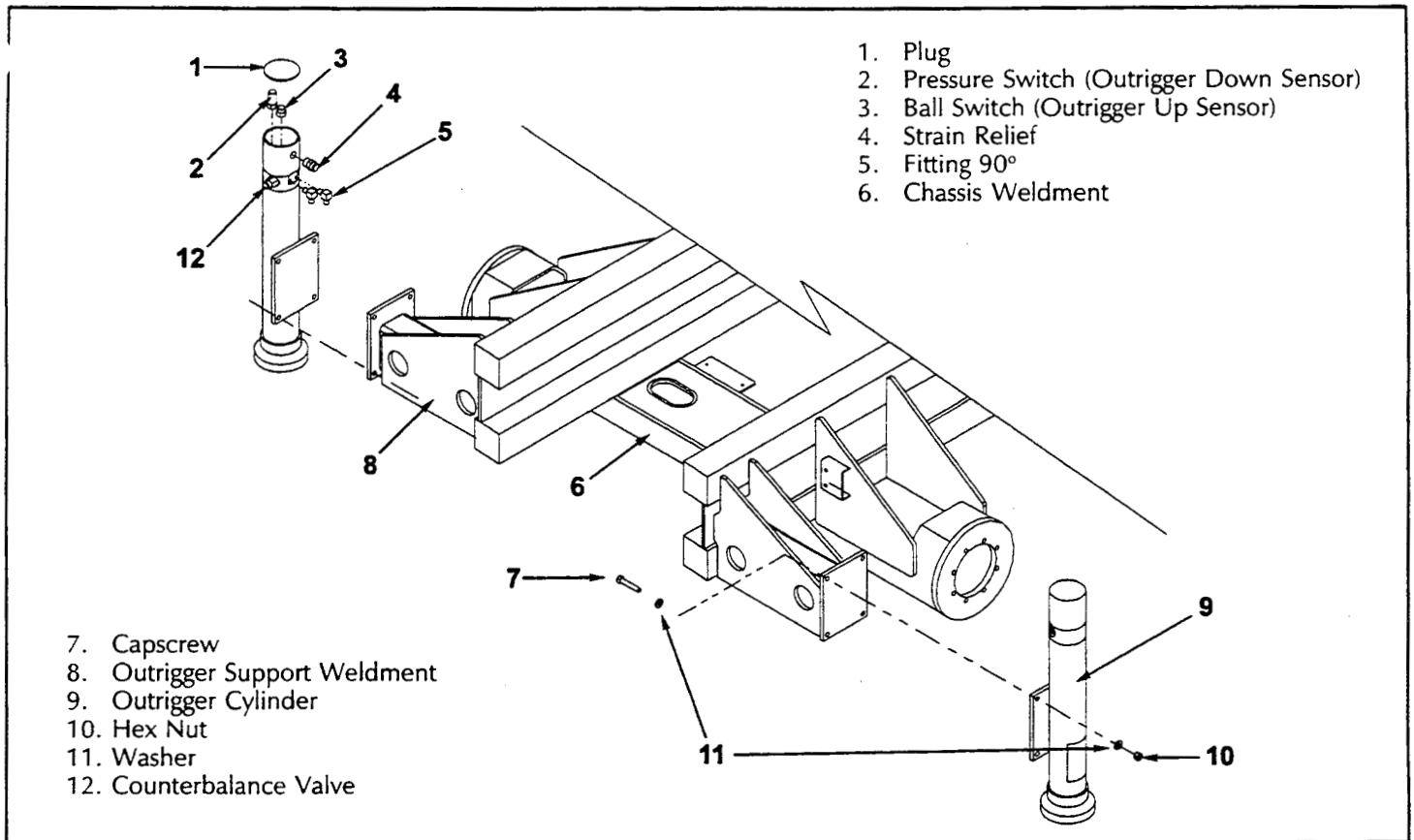

Figure 4-24: Outrigger Cylinder Installation

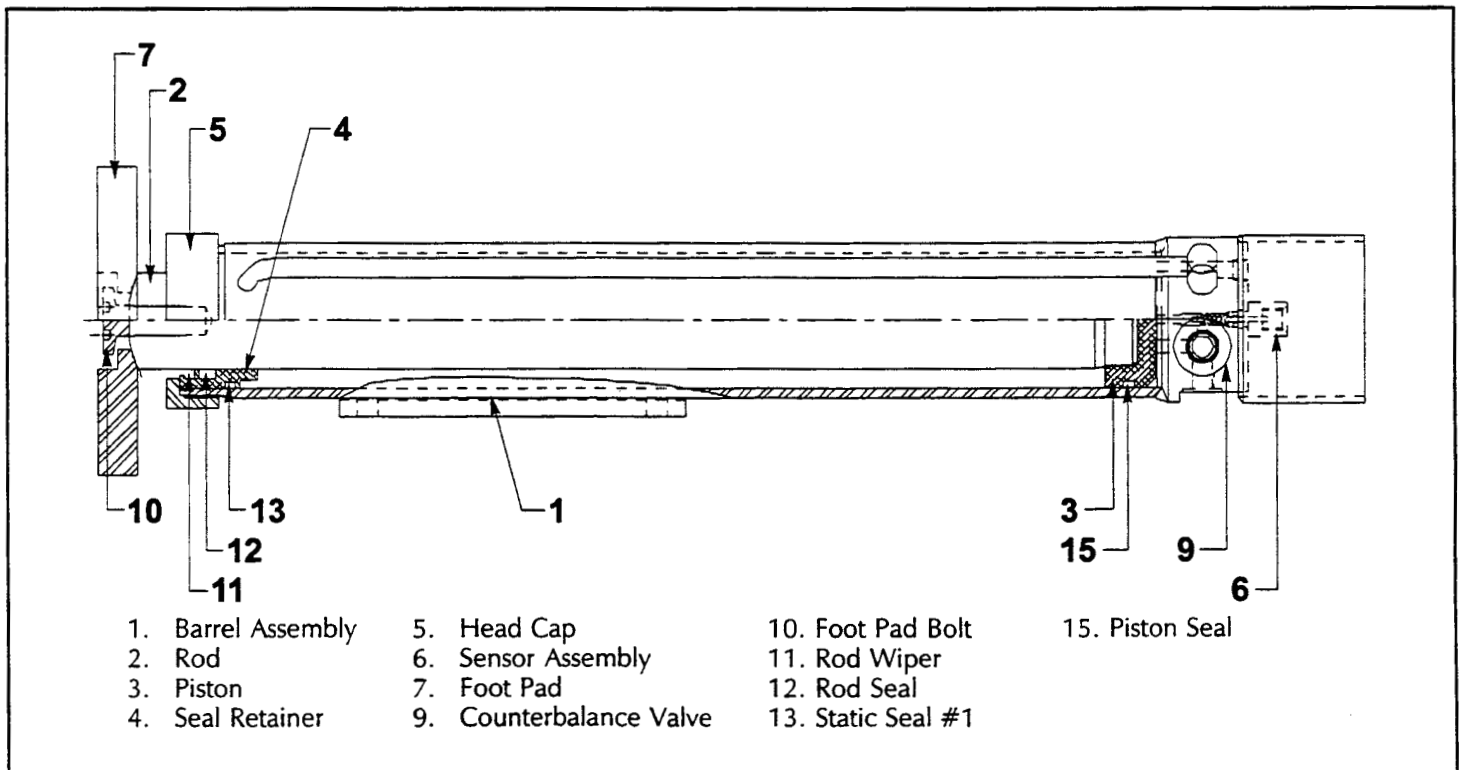

Figure 4-25: Outrigger Cylinder Cross Section

## 4.14 Torque Specifications (Table 4-2,3)

### FASTENERS

Use the following values to torque fasteners used on UpRight Work Platforms unless a specific torque value is called out for the part being installed.

Table 4-2: Bolt Torque

THREAD SIZE <small>American National Std.-UNC (course) Grade 5</small>	WIDTH ACROSS FLATS	TORQUE VALUE	
		ENGLISH	METRIC
1/4	7/16	110 In/Lbs	12 N·m
5/16	1/2	190 In/Lbs	22 N·m
3/8	9/16	30 Ft/Lbs	41 N·m
7/16	5/8	50 Ft/Lbs	68 N·m
1/2	3/4	75 Ft/Lbs	102 N·m
5/8	1 5/16	150 Ft/Lbs	203 N·m
3/4	1 1/8	250 Ft/Lbs	339 N·m
7/8	1 15/16	400 Ft/Lbs	542 N·m
1	1 1/2	600 Ft/Lbs	813 N·m

### HYDRAULIC COMPONENTS

Use the following values to torque hydraulic components used on UpRight Work Platforms.

**Note: Always lubricate threads with clean hydraulic oil prior to installation.**

Table 4-3: Hydraulic Component Torque

TYPE: SAE PART SERIES	CARTRIDGE POPPET		FITTINGS		HOSES	
	(Ft/Lbs)	(Nm)	(Ft/Lbs)	(Nm)	(In/Lbs)	(Nm)
#4	N/A	N/A	N/A	N/A	135-145	15-16
#6	N/A	N/A	10-20	14-27	215-245	24-28
#8	25-30	34-41	25-30	34-41	430-470	49-53
#10	35-40	47-54	35-40	47-54	680-750	77-85
#12	85-90	115-122	85-90	115-122	950-1050	107-131
#16	130-140	176-190	130-140	176-190	1300-1368	147-155

Coil nuts: 30 IN/Lbs (3 Nm)

## 5.0 Introduction

The following section on troubleshooting provides guidelines on the types of problems users may encounter in the field, helps determine the cause of problems, and suggests proper corrective action.

Careful inspection and accurate analysis of the symptoms listed in the Troubleshooting Guide will localize the trouble more quickly than any other method. This manual cannot cover all possible problems that may occur. If a specific problem is not covered in this manual, call our toll free number for service assistance.

Referring to Section 3.0 and 6.0 will aid in understanding the operation and function of the various components and systems of the LX 50 and help in diagnosing and repair of the machine.

### GENERAL PROCEDURE

Troubleshooting should be carried out in two steps. First, thoroughly study both hydraulic and electric schematics to determine possible causes. Loose terminal connections and short circuits are always a potential cause when troubleshooting. Second, check suspect components electrically, hydraulically and mechanically to determine if they are at fault.

#### ⚠ **WARNING** ⚠

When troubleshooting, ensure that the work platform is resting on a firm, level surface.

When performing any service which requires the platform to be raised, the Elevating Assembly must be blocked.

Disconnect the battery ground cable when replacing or testing the continuity of any electrical component.

FOR SERVICE ASSISTANCE, IN THE U.S.A., CALL:

**1-800-926-LIFT**

FROM OUTSIDE THE USA, CALL 1-209-896-5150

## 5.1 Troubleshooting Guide

Table 5-1: Troubleshooting Guide

PROBLEM	PROBABLE CAUSE	REMEDY
All functions inoperable, Engine does not start.	1. Blown Control Circuit Breaker	Check 15 amp Control Circuit Breaker. Replace if blown.
	2. Faulty Battery.	Check condition of battery. If serviceable, recharge battery. If defective, replace battery.
	3. Emergency Stop Switch failed open.	With the Emergency Stop Switch in the ON position, check continuity across the contacts. If none, replace.
	4. Key Switch.	Replace switch if inoperative.
Engine fails to start. Does not crank or cranks slowly.	1. Battery terminals corroded or loose.	Check and tighten terminals.
	2. Discharged battery.	Check condition of battery. If serviceable, recharge battery. If defective, replace battery.
	3. Starter Solenoid.	Replace the starter solenoid.
	4. Starter Motor.	Repair or replace starter.
	5. Key Switch.	Replace the switch.
	6. Main Circuit Breaker.	Check Circuit Breaker and replace if required.
	7. Emergency Stop Switch.	Replace switch if inoperative.
Engine cranks but will not start.	1. Engine Cold	Diesel: warm the Glow Plugs for 6 seconds prior to starting. Gasoline: Engage the Choke button while cranking.
	2. Out of fuel	Fill tank.
	3. Blocked fuel line.	Remove obstruction.
	4. Fuel Filter clogged.	Clean or replace filter.
	5. Air in the fuel system.	Tighten all fuel line fittings or damps. Diesel Engine: Bleed System
	6. Water in fuel system.	Drain tank if necessary to remove all water.
	7. Oil Pressure Switch inoperative.	Check Pressure Switch. Replace if faulty.
	8. Fuel Pump defective/damaged.	Check fuel delivery, replace pump if necessary.
	9. Ignition system faulty. (Gas / Propane)	Check for spark, repair Ignition System as necessary

# Troubleshooting

Table 5-1: Troubleshooting Guide (cont'd.)

PROBLEM	PROBABLE CAUSE	REMEDY
Engine starts then stops.	1. Low fuel level.	Fill fuel tank.
	2. Fuel Filter clogged.	Clean or replace the filter element.
	3. Air leaks in the fuel system.	Tighten all fuel line connections and clamps.
	4. Water in the fuel.	Drain the tank if necessary to remove all water.
	5. Fuel pump defective/damaged.	Check fuel delivery, replace pump if necessary.
	6. Clogged air filter.	Clean or replace air filter.
	7. Key Switch.	Switch defective or damaged. Replace the switch.
All functions inoperable. Engine starts.	1. Hydraulic Reservoir low.	Check hydraulic fluid level, top off as required.
	2. Faulty Hydraulic Pump.	Check pressure and delivery of the Hydraulic Pump. Replace if required.
	3. Damaged Drive Coupling.	Remove pump from engine and check coupling.
	4. Proportional Valve.	Check operation. Replace if required.
	5. Faulty Proportional Controller.	Check operation. Adjust or replace if required.
Loss of power	1. Clogged Air Filter.	Clean or replace the filter.
	2. Clogged Fuel Filter.	Replace the filter.
	3. Incorrect fuel.	Drain and refill tank with proper fuel.
	4. Fuel pump defective/damaged.	Replace the pump.
	5. Incorrect Fuel Mixture. (Gasoline)	Follow Idle Speed Adjustment procedure, Section 4.14.
Engine stops.	1. Fuel Tank empty.	Refill tank and prime system as required.
	2. Water in fuel.	Drain fuel system to remove all water and refill with fresh fuel.
	3. Oil Pressure Switch inoperative.	Check Pressure Switch. Replace if faulty.
All Controller functions inoperative.	1. Blown fuse.	Find short. Replace fuse.
	2. Key Switch.	Replace switch if inoperative.
	3. Faulty Interlock Switch.	Check Interlock Switch for continuity, replace if faulty.
	4. Faulty E-Stop Switch.	Replace E-Stop Switch if inoperative.
	5. Control Cable.	Test cable and replace if damaged.
	6. Faulty Controller.	Replace Controller if inoperative.
	7. Faulty Proportional Valve.	Replace Proportional Valve if inoperative.
	8. Faulty Cutout Relay.	Replace Cutout Relay if inoperative.
Platform will not elevate.	1. Platform overloaded.	Observe maximum load rating.
	2. Out of level.	Elevate only on level ground.
	3. Lift Relay Faulty.	Check / replace lift relay.
	4. Lift Valve faulty.	Test solenoid and replace if inoperable.
	5. Lift Relief Valve.	Check and Replace the relief valve if necessary.

PROBLEM	PROBABLE CAUSE	REMEDY	
Platform will not elevate. (cont'd)	6. Drive/Lift Switch on upper controls.	Test switch, replace if inoperable.	
	7. Hydraulic Pump.	Check for pressure and delivery. Repair or replace if inoperative.	
	8. Proportional Valve.	Test and replace if inoperable.	
	9. Proportional Controller.	Test controller, replace if inoperable.	
	Unit will not steer.	1. Steering Valve Coils (right and left).	Test coils, replace if inoperative.
		2. Open circuit in Control Cable.	Test cable for continuity, replace if defective.
3. Steering Valve.		Test valve, replace if not serviceable.	
4. Mechanical damage.		Replace damaged parts.	
5. Steering Switch.		Replace steering switch.	
6. Steering Orifice.		Remove and clean orifice.	
Unit will not drive. (Platform Lowered)	1. Drive/Lift Switch.	Position switch in <b>DRIVE</b> position. Test switch and replace if inoperative.	
	2. Forward or Reverse Solenoid Valve.	Test solenoid and replace if inoperative.	
	3. Control Cable.	Test cable and replace if damaged.	
	5. Proportional Controller.	Check controller adjustments, replace if inoperative.	
	6. Main Relief Valve.	Test relief valve and replace if not serviceable.	
	7. Hydraulic Pump.	Test pump pressure and delivery. Replace if not serviceable.	
	8. Hydraulic Motors.	Test hydraulic pressure at drive circuit. If normal, replace motors.	
	9. Drive Relay.	Check for contact closure when energized. If contacts do not close, replace the relay.	
	10. Lift/Drive Relay.	Check for continuity across contacts, if none replace the relay.	
	10. Cutout Relay.	If cutout relay is faulty, alarm will sound. Test and replace cutout relay.	
	11. Platform Down Switch.	Test and replace magnet switch	
	12. Forward or Reverse Relay.	Test / replace Forward or Reverse Relay.	
	13. Series / Parallel valve.	Trade Series / Parallel valves with Forward / Reverse Valves. If problem moves, replace affected valve.	
Unit will not drive full speed.	1. Down Limit Switch.	Test / replace magnet switch.	
	2. Series/Parallel Valve solenoids.	Test solenoid and replace if inoperable.	
	3. Proportional Controller.	Replace controller if not adjustable.	
	4. Proportional Valve.	Replace valve if Lift function is also affected.	
	5. Hydraulic Motors worn.	Inspect the motors and replace if not serviceable.	

Table 5-1: Troubleshooting Guide (cont'd.)

PROBLEM	PROBABLE CAUSE	REMEDY
Unit will not drive full speed (cont'd)	6. Hydraulic Pump worn.	Check pump pressure and delivery. Replace if not serviceable.
	7. Bi-Directional Relief Valves.	Check relief valve and replace if inoperable.
	8. Torque Selector Switch.	Test / Replace switch.
	9. Platform Down Relay.	Check for contact closure when energized. If contacts do not close, replace the relay.
Unit will not drive (Platform elevated)	1. Proportional Controller	Check Controller Low Speed Adjustment. Replace if not adjustable.
No drive in one direction, other direction okay.	1. Faulty Drive Relay.	Test FWD contacts for continuity replace relay if required.
	2. Faulty Drive Coil.	Test Forward Coil if proper voltage is present and coil is not magnetized, replace.
	3. Faulty Drive Valve.	Trade FWD and REV valves, if symptoms change, replace affected valve.
	4. Counterbalance Valves.	Trade Counterbalance Valves. If symptoms change, replace affected valve.
Platform drifts down.	1. Emergency Lowering/Down Valve partly open or faulty.	Ensure that the Emergency Lowering Valve is completely closed. If the platform still drifts down, replace the valve.
	2. Faulty valve O-rings.	Check and replace O-rings on Emergency Lowering/Down Valve and piston.
	3. Lift Cylinder.	Open Weep Line, check for bypass flow.
Platform will not lower.	1. Blown fuse.	Locate electrical short and then replace fuse.
	2. Down Valve Solenoid Coil.	Test coil and replace if inoperable.
	3. Control Cable.	Check cable and replace if damaged.
	4. Lift/Drive Relay.	Check down contacts for continuity, replace relay if necessary.
Brake does not release.	1. Brake Release Valve closed.	Open valve.
	2. Brake faulty.	Check for oil leakage, replace brake seals if necessary.
Brake will not engage	1. Brake Release Valve closed.	Open valve.

*NOTES*



## 6.0 Introduction

This section contains electrical and hydraulic power schematics, and associated information for maintenance purposes.

The diagrams are to be used in conjunction with *Table 5-1: Troubleshooting Guide*. They allow understanding of the makeup and functions of the systems for checking, tracing, and faultfinding during trouble analysis.

The diagrams appear in the following order:

### *Section 6.1 Electrical Schematics*

Figure 6-1: Two Wheel Drive, Gasoline Model

Figure 6-2: Two Wheel Drive, Diesel Model  
S/N 1330 - 2219

Figure 6-3: Two Wheel Drive, Diesel Model  
S/N 2219 - Current

Figure 6-4: Four Wheel Drive, Gasoline / Propane Model

Figure 6-5: Four Wheel Drive, Diesel Model  
S/N 1330 - 2219

Figure 6-6: Four Wheel Drive, Diesel Model  
S/N 2219 - Current

Figure 6-7: Two Wheel Drive Gasoline  
Dual Deck with Outriggers

Figure 6-8: Two Wheel Drive Diesel  
Dual Deck with Outriggers

Figure 6-9: Four Wheel Drive Diesel  
Dual Deck with Outriggers

### *Section 6.2 Hydraulic Schematics*

Figure 6-10: Two Wheel Drive Models

Figure 6-11: Four Wheel Drive Models

Figure 6-12: Two Wheel Drive Models w/ Outriggers

Figure 6-13: Four Wheel Drive Models w/ Outriggers

### *Section 6.3 Component Location*

Figure 6-14: Outrigger Manifold

Figure 6-15: 2WD Hydraulic Manifold

Figure 6-16: 4WD Hydraulic Manifold

Figure 6-17: Kubota Gas Engine Diagram

Figure 6-18: Kubota Diesel Engine Diagram

### *Section 6.4 Lower Controller*

Figure 6-19: Lower Controller

Figure 6-20: Terminal Strip, Relay Identification

Figure 6-21: Electrical Schematic, Lower Controller  
Gasoline Models

Figure 6-22: Electrical Schematic, Lower Controller  
Diesel Models

### *Section 6.5 Platform Controller*

Figure 6-23: Platform Control Box

Figure 6-24: Electrical Schematic, Platform Controller  
Gasoline Models

Figure 6-25: Electrical Schematic, Platform Controller  
Diesel Models

Figure 6-26: Electrical Schematic, Platform Controller  
Dual Deck with Outriggers

## 6.1 Electrical Schematics

Table 6-1: 067535-003 Two Wheel Drive, Gasoline Model

REFERENCE DESIGNATION	NAME	FUNCTION	LOCATION
ALM 1	Alarm, Tilt	Provides warning sound when slope of machine exceeds 3° side to side, or fore and aft.	Lower control box, exterior upper left side. Operated by the white wire.
ALM 2	Alarm, Down	Provides warning sound when deck is lowering.	Lower control box, exterior upper left side. Operated by red wire.
ALT	Alternator	Maintains current during operation.	Power module, front left side of engine.
BAT	Battery	Provides power for starting engine.	Control module. On left in rear of module.
D1	Diode	Supplies power to down relay.	Between T10 and T11 on fanning strip.
D2	Diode	Supplies power to high speed enable circuit.	Between T16 and T17 on fanning strip.
D3	Diode	Supplies power to high speed enable circuit.	Between T17 and T18 on fanning strip.
D4	Diode	Supplies power to Throttle Solinoid.	Between T18 and T19 on fanning strip.
D5	Diode	Supplies power to power relay.	Lower control box by power relay.
D6	Diode	Supplies power to power relay.	Lower control box by power relay.
D7	Diode	Supplies power to drive relay.	Lower control box by drive relay.
F1	Emergency Stop Circuit Breaker	Supplies Power to Upper Control Ignition Switch.	Lower control box mounted in panel, lower right hand.
F2	Power Circuit Breaker	Supplies power to all function solenoids.	Lower control box mounted in panel, lower left hand.
L1	Drive Enable Light	Indicates Drive Enable	Platform Control Box
LS1	Down Limit Switch	Bypasses level sensor, supplying power to cutout relay when platform is lowered.	Under scissors, near front right hand side of chassis.
LS2	Down Limit Switch	Supplies power to drive and platform down relays, and high speed enable circuit on controller when platform is lowered.	Under scissors, near front right hand side of chassis.
MOD1	Ignition Module	Controls spark for engine.	Right side of engine, in power module.
MOT1	Starter Motor, and Solenoid	Provides power to starter motor from battery.	Left side of engine, in power module.
PS1	Oil Pressure Switch	Cuts power to engine when oil pressure falls to dangerous level.	Left side of engine, in power module.
PU1	Electric Fuel Pump	Supplies fuel to engine.	Top rear of engine, in power module.
R1	Forward Relay	Switches power to forward solenoid.	Lower control box, second row, second relay from left.
R2	Reverse Relay	Switches power to reverse solenoid.	Lower control box, second row, third relay from left.
R3	Tilt Alarm Relay	Switches power to tilt alarm.	Lower control box, second row, fourth relay from left.
R4	Up Relay	Switches power to lift solenoid.	Lower control box, second row, fifth relay from left.
R5	Series / Parallel Relay	Switches power to series / parallel solenoids.	Lower control box, second row, sixth relay from left.
R6	Power Relay	Switches power to all solenoids and engine.	Lower control box, first row, fourth relay from left.
R7	Down Relay	Switches power to down solenoid.	Lower control box, second row, seventh relay from left.

REFERENCE DESIGNATION	NAME	FUNCTION	LOCATION
R8	Down Alarm Relay	Switches power to down alarm.	Lower control box, second row, eighth relay from left.
R9	Steer Right Relay	Switches power to steer right solenoid.	Lower control box, second row, ninth relay from left.
R10	Steer Left Relay	Switches power to steer left solenoid.	Lower control box, second row, tenth relay from left.
R11	Throttle Relay	Switches power to throttle solenoid.	Lower control box, second row, eleventh relay from left.
R12	Choke Relay	Switches power to choke solenoid.	Lower control box, second row, twelfth relay from left.
R13	Drive / Lift Relay	Directs power from forward (S3) and reverse (S2) switches to either forward / reverse or up / down relays.	Lower control box, first row, first relay from right.
R14	Drive Relay	Cuts power to forward and reverse relays when cutout relay is not energized and platform is elevated.	Lower control box, first row, second relay from left.
R15	Cutout Relay	Cuts power to drive and up relays when not energized by level sensor.	Lower control box, first row, third relay from left.
R16	Platform Down Relay	Cuts power to series / parallel relay when platform is elevated, selecting high torque mode.	Lower control box, second row, first relay from left.
R17	Ignition Relay	Power to Platform Ignition Switch	Upper control box.
RES1	Proportional Resistor	Limits current to proportional solenoid.	Lower control box.
S1	Micro Switch	Supplies power to controller.	Upper control box, joystick.
S2	Reverse Micro Switch	Supplies power to drive / lift relay, forward / up contacts.	Upper control box, joystick.
S3	Forward Micro Switch	Supplies power to drive / lift relay, reverse / down contacts.	Upper control box, joystick.
S4	Interlock Micro Switch (Deadman Switch)	Interrupts power to controls when not engaged.	Upper control box, inside joystick handle.
S5	Steering Micro Switch (two)	Supplies power to steer left and steer right relays.	Upper control box, inside joystick handle.
S6,7	Drive / Lift Switch	Supplies Power to steering micro switch (drive) or to drive / lift relay (lift).	Upper control box, to the right of joystick.
S8	Torque Selector Switch	Supplies power to series / parallel relay.	Upper control box, to the right of joystick.
S9	Ignition Switch	Supplies power to upper controls, engine, and starter motor solenoid.	Upper control box, right side.
S10	Choke Switch	Supplies power to choke relay.	Upper control box, left side.
S11	Emergency Stop Switch	Cuts power to upper controls and engine.	Upper control box, to the left of joystick.
S12	Engine Stop Switch	Cuts power to ignition module, and fuel shut-off solenoid.	Lower control box, in panel second from top, second from right.
S13	Starter Switch	Supplies power to starter motor solenoid.	Lower control box, in panel, top, second from right.
S14	Fuel Selector Switch	Selects LP or Gas	Engine Module
S15	Emergency Stop Switch	Cuts power to lower controls and engine.	Lower control box, in panel, top, first from left.
S16	Chassis / Platform Switch	Supplies power to either upper or lower controls.	Lower control box, in panel, second from top, second from left.
S17	Down Switch	Supplies power to down relay.	Lower control box, in panel, third from top, first from left.

Table 6-1: (cont.)

REFERENCE DESIGNATION	NAME	FUNCTION	LOCATION
S18	Lift Switch	Raise Platform	Lower control box
S19	Throttle Switch	Supplies power to throttle relay.	Lower control box, in panel, top, first from right.
S20	Choke Switch	Supplies power to choke relay.	Lower control box, in panel, second from top, first from right.
SEN1	Level Sensor	Provides power to cutout relay when machine is level.	Control module.
SOL1	Throttle Solenoid	Controls engine throttle.	Power module, engine, right side.
SOL2	Run Solenoid	Controls fuel valve.	Power module, engine, on injection pump.
SOL3	Gas Solenoid	Controls Fuel Valve.	Power module, inline with gasoline supply.
SOL4	Propane Shut-Off Solenoid	Controls propane valve.	Power module, inline propane supply.
SOL5	Proportional Solenoid	Controls proportional valve.	Right side of manifold, port marked 'G'.
SOL6	Forward Solenoid	Controls forward valve.	Right side of valve manifold, port marked 'K'.
SOL7	Reverse Solenoid	Controls reverse valve.	Right side of manifold, port marked 'L'.
SOL8	Lift Solenoid.	Controls lift valve.	Right side of manifold, port marked 'J'.
SOL10	Series / Parallel Solenoid (two)	Controls series / parallel valves.	Front side of manifold, ports marked 'Q' & 'R'.
SOL12	Down Solenoid	Controls down valve.	Lift cylinder, lower end.
SOL13	Steer Right Solenoid	Controls steer valve when steering right.	Top of manifold, on steer valve.
SOL14	Steer Left Solenoid	Controls steer valve when steering left.	Top of manifold, on steer valve.
SOL15	Remote Starter Solenoid	Start Engine	Power module, engine, right side.
SOL16	Choke Solenoid	Controls engine choke.	Power module, engine, right side.

Note: See Figure 6-20 for relay, terminal strip locations.

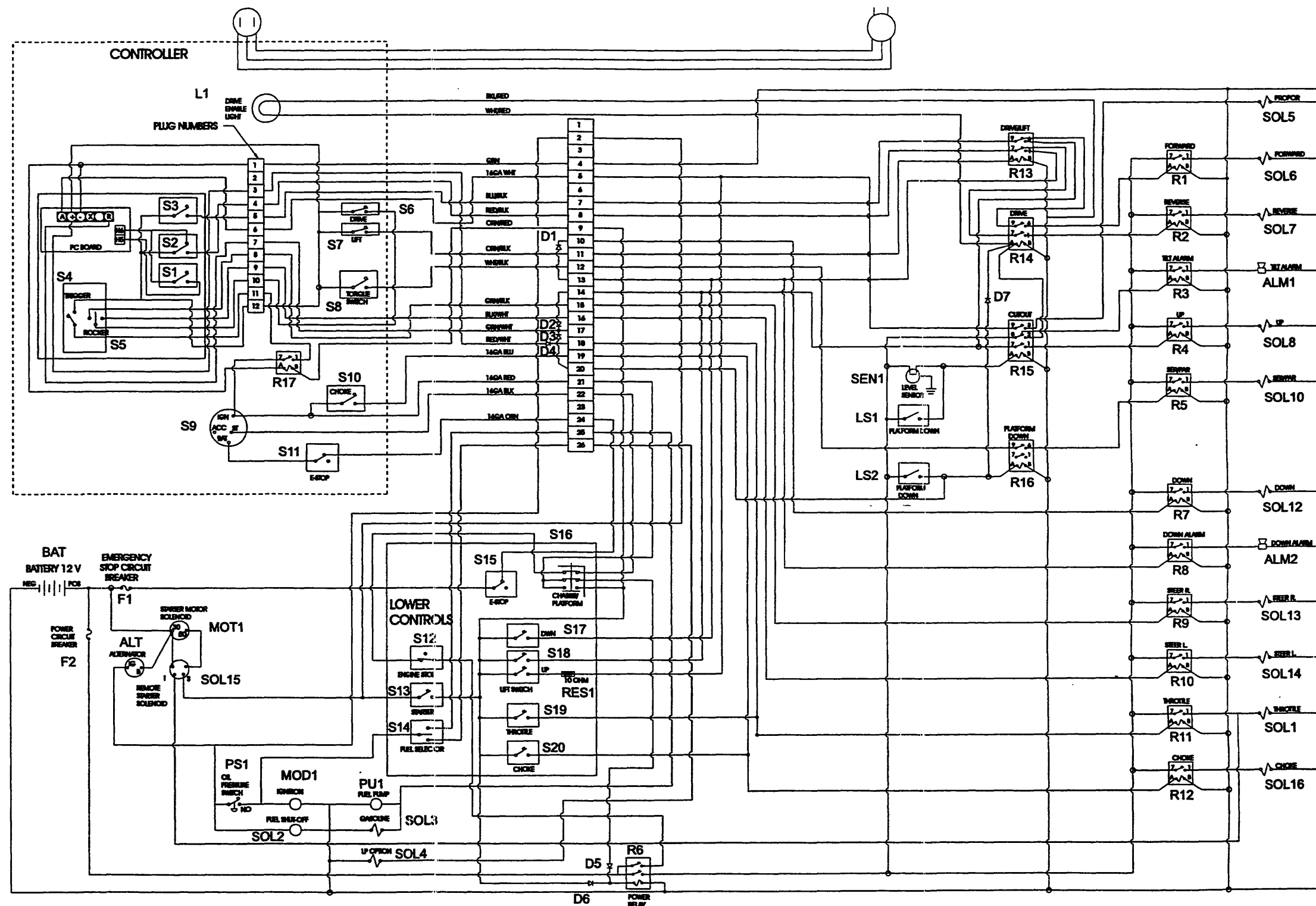

Figure 6-1: 067535-003 Two Wheel Drive, Gasoline Model

## 6.1 Electrical Schematics

Table 6-2: 067535-002 Two-Wheel Drive, Diesel Model (S/N: 1331 - 2219 )

REFERENCE DESIGNATION	NAME	FUNCTION	LOCATION
ALM 1	Alarm, Tilt	Provides warning sound when slope of machine exceeds 3° side to side, or fore and aft.	Lower control box, exterior upper left side. Operated by the white wire.
ALM 2	Alarm, Down	Provides warning sound when deck is lowering.	Lower control box, exterior upper left side. Operated by red wire.
ALT	Alternator	Maintains current during operation.	Power module, front left side of engine.
BAT	Battery	Provides power for starting engine.	Control module. On left in rear of module.
D1	Diode	Supplies power to down relay.	Between T10 and T11 on fanning strip.
D2	Diode	Supplies power to high speed enable circuit.	Between T16 and T17 on fanning strip.
D3	Diode	Supplies power to high speed enable circuit.	Between T17 and T18 on fanning strip.
D4	Diode	Supplies power to Throttle Solenoid.	Between T18 and T19 on fanning strip.
D5	Diode	Supplies power to power relay.	Lower control box by power relay.
D6	Diode	Supplies power to power relay.	Lower control box by power relay.
D7	Diode	Supplies power to drive relay.	Lower control box by drive relay.
F1	Emergency Stop Circuit Breaker	Supplies Power to Upper Control Ignition Switch.	Lower control box mounted in panel, lower right hand.
F2	Power Circuit Breaker	Supplies power to all function solenoids.	Lower control box mounted in panel, lower left hand.
L1	Drive Enable Light	Indicates Drive Enabled	Upper control box
LS1	Down Limit Switch	Bypasses level sensor, supplying power to cutout relay when platform is lowered.	Under scissors, near front right hand side of chassis.
LS2	Down Limit Switch	Supplies power to drive and platform down relays, and high speed enable circuit on controller when platform is lowered.	Under scissors, near front right hand side of chassis.
MOT1	Starter Motor, and Solenoid	Provides power to starter motor from battery.	Left side of engine, in power module.
PS1	Oil Pressure Switch	Cuts power to engine when oil pressure falls to dangerous level.	Left side of engine, in power module.
R1	Forward Relay	Switches power to forward solenoid.	Lower control box, second row, second relay from left.
R2	Reverse Relay	Switches power to reverse solenoid.	Lower control box, second row, third relay from left.
R3	Tilt Alarm Relay	Switches power to tilt alarm.	Lower control box, second row, fourth relay from left.
R4	Up Relay	Switches power to lift solenoid.	Lower control box, second row, fifth relay from left.
R5	Series / Parallel Relay	Switches power to series / parallel solenoids.	Lower control box, second row, sixth relay from left.
R7	Down Relay	Switches power to down solenoid.	Lower control box, second row, seventh relay from left.
R8	Down Alarm Relay	Switches power to down alarm.	Lower control box, second row, eighth relay from left.
R9	Steer Right Relay	Switches power to steer right solenoid.	Lower control box, second row, ninth relay from left.
R10	Steer Left Relay	Switches power to steer left solenoid.	Lower control box, second row, tenth relay from left.
R11	Throttle Relay	Switches power to throttle solenoid.	Lower control box, second row, eleventh relay from left.

REFERENCE DESIGNATION	NAME	FUNCTION	LOCATION
R13	Drive / Lift Relay	Directs power from forward (S3) and reverse (S2) switches to either forward / reverse or up / down relays.	Lower control box, first row, first relay from right.
R14	Drive Relay	Cuts power to forward and reverse relays when cutout relay is not energized and platform is elevated.	Lower control box, first row, second relay from left.
R15	Cutout Relay	Cuts power to drive and up relays when not energized by level sensor.	Lower control box, first row, third relay from left.
R16	Platform Down Relay	Cuts power to series / parallel relay when platform is elevated, selecting high torque mode.	Lower control box, second row, first relay from left.
R17	Power Relay	Switches power to all solenoids and engine.	Lower control box, first row, fourth relay from left.
R18	Starter Relay	Switches power to starter.	Power module, engine assembly.
R19	Ignition Relay	Enables Engine Start	Upper Controller
R20	Throttle Relay	Controls Engine Speed	Engine
R21	Glow Plug Relay	Heat Glow Plugs	Lower Control box
RES1	Proportional Resistor	Limits current to proportional solenoid.	Lower control box.
RES2	Glow Plugs	Used when starting cold engine.	Diesel engine cylinder head.
S1	Micro Switch	Supplies power to controller.	Upper control box, joystick.
S2	Reverse Micro Switch	Supplies power to drive / lift relay, forward / up contacts.	Upper control box, joystick.
S3	Forward Micro Switch	Supplies power to drive / lift relay, reverse / down contacts.	Upper control box, joystick.
S4	Interlock Micro Switch (Deadman Switch)	Interrupts power to controls when not engaged.	Upper control box, inside joystick handle.
S5	Steering Micro Switch (two)	Supplies power to steer left and steer right relays.	Upper control box, inside joystick handle.
S6,7	Drive / Lift Switch	Supplies Power to steering micro switch (drive) or to drive / lift relay (lift).	Upper control box, to the right of joystick.
S8	Torque Selector Switch	Supplies power to series / parallel relay.	Upper control box, to the right of joystick.
S9	Ignition Switch	Supplies power to upper controls, engine, and starter motor solenoid.	Upper control box, right side.
S10	Glow Plug Switch	Supplies power to glow plug relay.	Upper control box, left side.
S11	Emergency Stop Switch	Cuts power to upper controls and engine.	Upper control box, to the left of joystick.
S12	Engine Stop Switch	Cuts power to ignition module, and fuel shut-off solenoid.	Lower control box, in panel second from top, second from right.
S13	Starter Switch	Supplies power to starter motor solenoid.	Lower control box, in panel, top, second from right.
S15	Emergency Stop Switch	Cuts power to lower controls and engine.	Lower control box, in panel, top, first from left.
S16	Chassis / Platform Switch	Supplies power to either upper or lower controls.	Lower control box, in panel, second from top, second from left.
S17	Down Switch	Supplies power to down relay.	Lower control box, in panel, third from top, first from left.
S18	Lift Switch	Supplies power to up relay.	Lower control box, in panel, second from top, first from left.

Table 6-2: (cont.)

REFERENCE DESIGNATION	NAME	FUNCTION	LOCATION
S19	Throttle Switch	Supplies power to throttle relay.	Lower control box, in panel, top, first from right.
S20	Glow Plug Switch	Supplies power to glow plug relay.	Lower control box, in panel, second from top, first from right.
S21	Up Limit Switch	Limits Lift Cylinder Extension	Chassis
SEN1	Level Sensor	Provides power to cutout relay when machine is level.	Control module.
SOL1	Proportional Solenoid	Controls proportional valve.	Right side of manifold, port marked 'G'.
SOL2	Forward Solenoid	Controls forward valve.	Right side of valve manifold, port marked 'K'.
SOL3	Reverse Solenoid	Controls reverse valve.	Right side of manifold, port marked 'L'.
SOL4	Lift Solenoid.	Controls lift valve.	Right side of manifold, port marked 'J'.
SOL5	Series / Parallel Solenoid (two)	Controls series / parallel valves.	Front side of manifold, ports marked 'Q' & 'R'.
SOL6	Down Solenoid	Controls down valve.	Lift cylinder, lower end.
SOL7	Steer Right Solenoid	Controls steer valve when steering right.	Top of manifold, on steer valve.
SOL8	Steer Left Solenoid	Controls steer valve when steering left.	Top of manifold, on steer valve.
SOL9	Run Solenoid	Controls fuel valve.	Power module, engine, on injection pump.
SOL10	Throttle Solenoid	Controls Engine Speed	Engine

Note: See Figure 6-20 for relay, terminal strip locations.

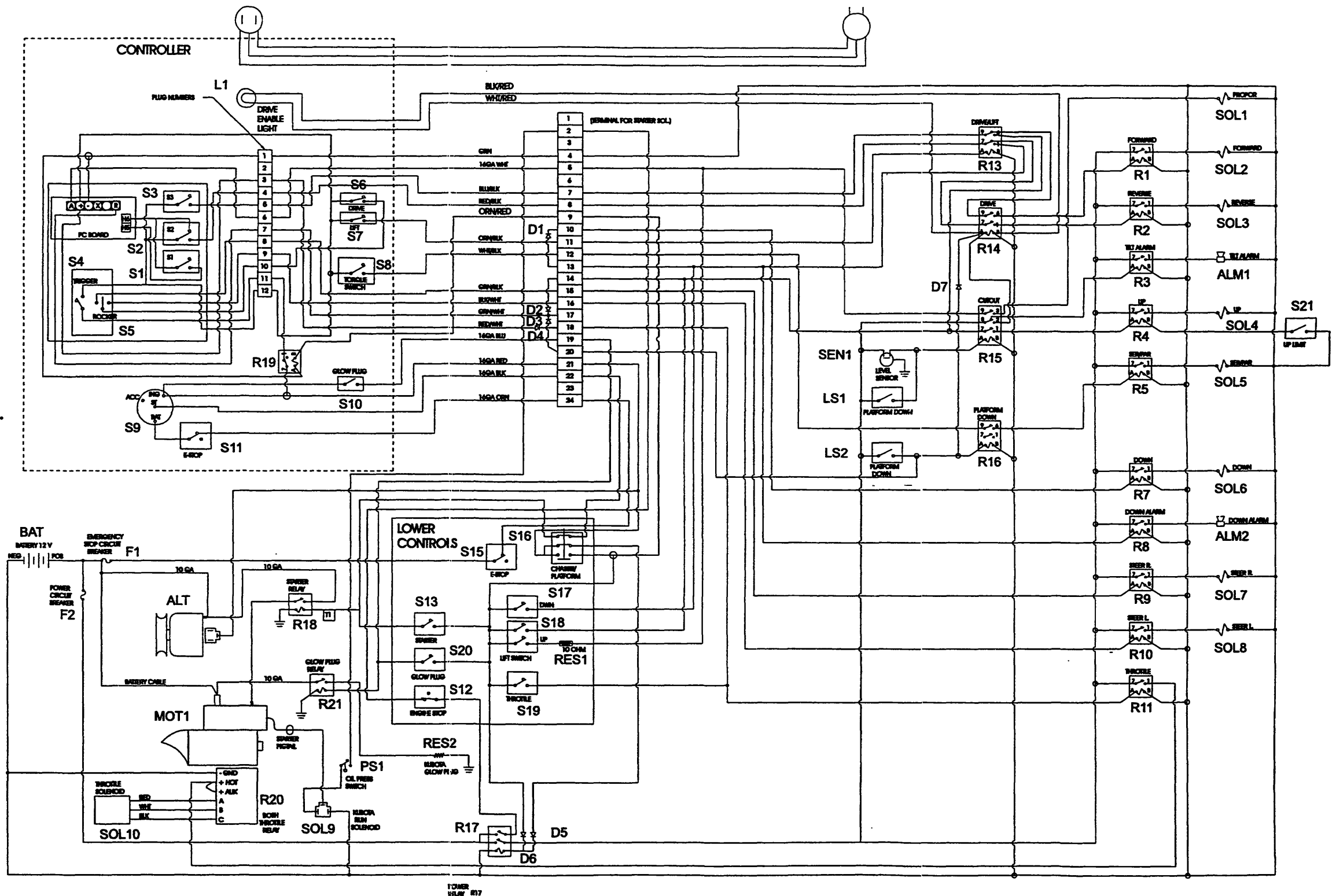

Figure 6-2: 067535-002 Two Wheel Drive, Diesel Model (Serial Number 1331 - 2219)

## 6.1 Electrical Schematics

Table 6-3: 067535-002 Two-Wheel Drive, Diesel Model (S/N: 2219 - Current)

REFERENCE DESIGNATION	NAME	FUNCTION	LOCATION
ALM 1	Alarm, Tilt	Provides warning sound when slope of machine exceeds 3° side to side, or fore and aft.	Lower control box, exterior upper left side. Operated by the white wire.
ALM 2	Alarm, Down	Provides warning sound when deck is lowering.	Lower control box, exterior upper left side. Operated by red wire.
ALT	Alternator	Maintains current during operation.	Power module, front left side of engine.
BAT	Battery	Provides power for starting engine.	Control module. On left in rear of module.
D1	Diode	Supplies power to down relay.	Between T10 and T11 on fanning strip.
D2	Diode	Supplies power to high speed enable circuit.	Between T16 and T17 on fanning strip.
D3	Diode	Supplies power to high speed enable circuit.	Between T17 and T18 on fanning strip.
D4	Diode	Supplies power to Throttle Solenoid.	Between T18 and T19 on fanning strip.
D5	Diode	Supplies power to power relay.	Lower control box by power relay.
D6	Diode	Supplies power to power relay.	Lower control box by power relay.
D7	Diode	Supplies power to drive relay.	Lower control box by drive relay.
F1	Emergency Stop Circuit Breaker	Supplies Power to Upper Control Ignition Switch.	Lower control box mounted in panel, lower right hand.
F2	Power Circuit Breaker	Supplies power to all function solenoids.	Lower control box mounted in panel, lower left hand.
L1	Drive Enable Light	Indicates Drive Enabled	Upper control box
LS1	Down Limit Switch	Bypasses level sensor, supplying power to cutout relay when platform is lowered.	Under scissors, near front right hand side of chassis.
LS2	Down Limit Switch	Supplies power to drive and platform down relays, and high speed enable circuit on controller when platform is lowered.	Under scissors, near front right hand side of chassis.
MOT1	Starter Motor, and Solenoid	Provides power to starter motor from battery.	Left side of engine, in power module.
PS1	Oil Pressure Switch	Cuts power to engine when oil pressure falls to dangerous level.	Left side of engine, in power module.
R1	Forward Relay	Switches power to forward solenoid.	Lower control box, second row, second relay from left.
R2	Reverse Relay	Switches power to reverse solenoid.	Lower control box, second row, third relay from left.
R3	Tilt Alarm Relay	Switches power to tilt alarm.	Lower control box, second row, fourth relay from left.
R4	Up Relay	Switches power to lift solenoid.	Lower control box, second row, fifth relay from left.
R5	Series / Parallel Relay	Switches power to series / parallel solenoids.	Lower control box, second row, sixth relay from left.
R7	Down Relay	Switches power to down solenoid.	Lower control box, second row, seventh relay from left.
R8	Down Alarm Relay	Switches power to down alarm.	Lower control box, second row, eighth relay from left.
R9	Steer Right Relay	Switches power to steer right solenoid.	Lower control box, second row, ninth relay from left.
R10	Steer Left Relay	Switches power to steer left solenoid.	Lower control box, second row, tenth relay from left.
R11	Throttle Relay	Switches power to throttle solenoid.	Lower control box, second row, eleventh relay from left.

REFERENCE DESIGNATION	NAME	FUNCTION	LOCATION
R13	Drive / Lift Relay	Directs power from forward (S3) and reverse (S2) switches to either forward / reverse or up / down relays.	Lower control box, first row, first relay from right.
R14	Drive Relay	Cuts power to forward and reverse relays when cutout relay is not energized and platform is elevated.	Lower control box, first row, second relay from left.
R15	Cutout Relay	Cuts power to drive and up relays when not energized by level sensor.	Lower control box, first row, third relay from left.
R16	Platform Down Relay	Cuts power to series / parallel relay when platform is elevated, selecting high torque mode.	Lower control box, second row, first relay from left.
R17	Power Relay	Switches power to all solenoids and engine.	Lower control box, first row, fourth relay from left.
R18	Starter Relay	Switches power to starter.	Power module, engine assembly.
R19	Ignition Relay	Enables Engine Start	Upper Controller
R20	Glow Plug Relay	Heat Glow Plugs	Lower control box
RES1	Proportional Resistor	Limits current to proportional solenoid.	Lower control box.
RES2	Glow Plugs	Used when starting cold engine.	Diesel engine cylinder head.
S1	Micro Switch	Supplies power to controller.	Upper control box, joystick.
S2	Reverse Micro Switch	Supplies power to drive / lift relay, forward / up contacts.	Upper control box, joystick.
S3	Forward Micro Switch	Supplies power to drive / lift relay, reverse / down contacts.	Upper control box, joystick.
S4	Interlock Micro Switch (Deadman Switch)	Interrupts power to controls when not engaged.	Upper control box, inside joystick handle.
S5	Steering Micro Switch (two)	Supplies power to steer left and steer right relays.	Upper control box, inside joystick handle.
S6,7	Drive / Lift Switch	Supplies Power to steering micro switch (drive) or to drive / lift relay (lift).	Upper control box, to the right of joystick.
S8	Torque Selector Switch	Supplies power to series / parallel relay.	Upper control box, to the right of joystick.
S9	Ignition Switch	Supplies power to upper controls, engine, and starter motor solenoid.	Upper control box, right side.
S10	Glow Plug Switch	Supplies power to glow plug relay.	Upper control box, left side.
S11	Emergency Stop Switch	Cuts power to upper controls and engine.	Upper control box, to the left of joystick.
S12	Engine Stop Switch	Cuts power to ignition module, and fuel shut-off solenoid.	Lower control box, in panel second from top, second from right.
S13	Starter Switch	Supplies power to starter motor solenoid.	Lower control box, in panel, top, second from right.
S15	Emergency Stop Switch	Cuts power to lower controls and engine.	Lower control box, in panel, top, first from left.
S16	Chassis / Platform Switch	Supplies power to either upper or lower controls.	Lower control box, in panel, second from top, second from left.
S17	Down Switch	Supplies power to down relay.	Lower control box, in panel, third from top, first from left.
S18	Lift Switch	Supplies power to up relay.	Lower control box, in panel, second from top, first from left.
S19	Throttle Switch	Supplies power to throttle relay.	Lower control box, in panel, top, first from right.
S20	Glow Plug Switch	Supplies power to glow plug relay.	Lower control box, in panel, second from top, first from right.

Table 6-3: (cont.)

REFERENCE DESIGNATION	NAME	FUNCTION	LOCATION
S21	Up Limit Switch	Limit Lift Cylinder Extension	Chassis
SEN1	Level Sensor	Provides power to cutout relay when machine is level	Control module.
SOL1	Proportional Solenoid	Controls proportional valve.	Right side of manifold, port marked 'G'.
SOL2	Forward Solenoid	Controls forward valve.	Right side of valve manifold, port marked 'K'.
SOL3	Reverse Solenoid	Controls reverse valve.	Right side of manifold, port marked 'L'.
SOL4	Lift Solenoid.	Controls lift valve.	Right side of manifold, port marked 'J'.
SOL5	Series / Parallel Solenoid (two)	Controls series / parallel valves.	Front side of manifold, ports marked 'Q' & 'R'.
SOL6	Down Solenoid	Controls down valve.	Lift cylinder, lower end.
SOL7	Steer Right Solenoid	Controls steer valve when steering right.	Top of manifold, on steer valve.
SOL8	Steer Left Solenoid	Controls steer valve when steering left.	Top of manifold, on steer valve.
SOL9	Run Solenoid	Controls fuel valve.	Power module, engine, on injection pump.
SOL10	Throttle Solenoid	Controls Engine Speed	Engine Module

Note: See Figure 6-20 for relay, terminal strip locations.

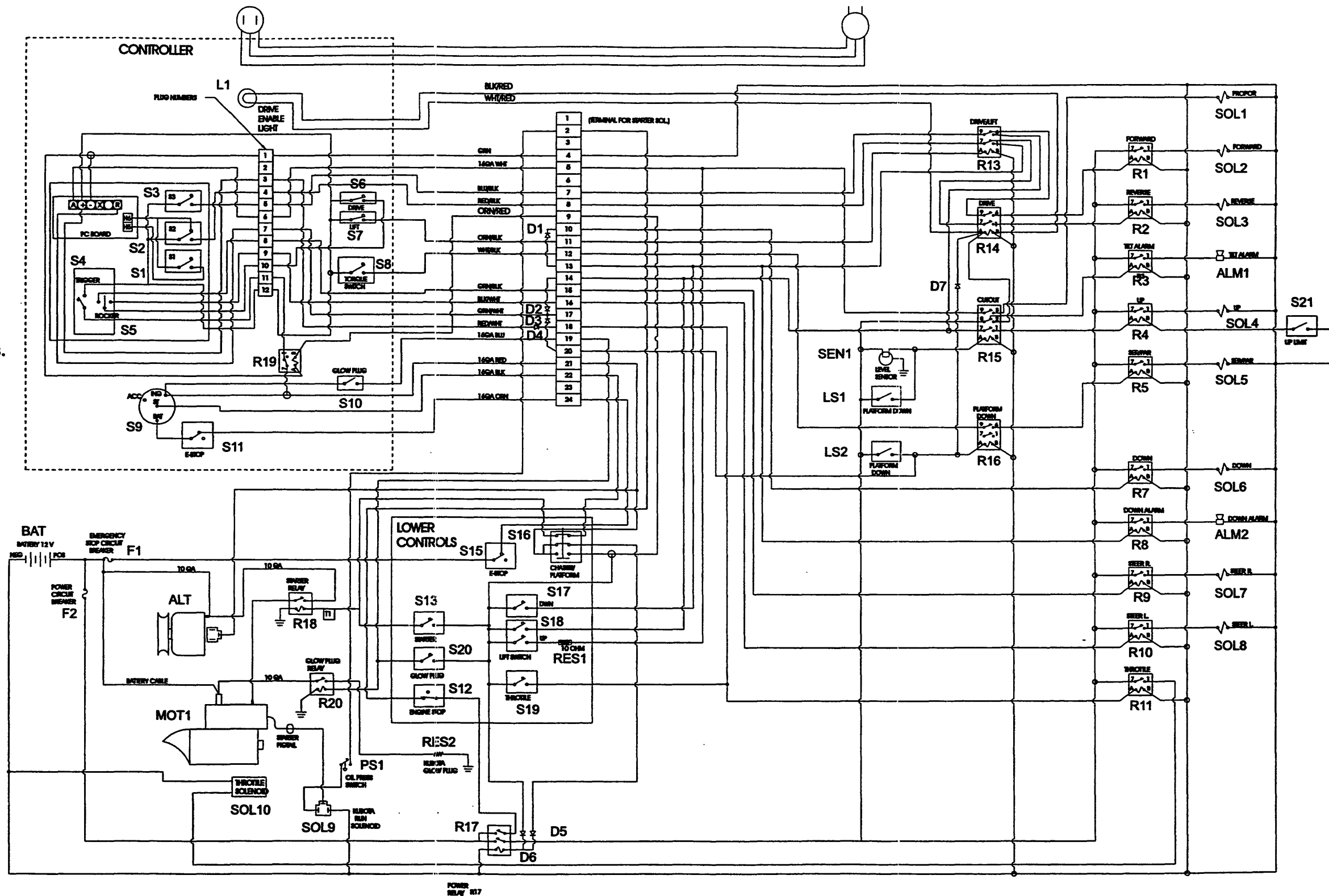

Figure 6-3: 067535-002 Two Wheel Drive, Diesel Model (Serial Number 2219 - Current)

## 6.1 Electrical Schematics

Table 6-4: 067535-000 Four Wheel Drive, Gasoline Model

REFERENCE DESIGNATION	NAME	FUNCTION	LOCATION	REFERENCE DESIGNATION	NAME	FUNCTION	LOCATION
ALM 1	Alarm, Tilt	Provides warning sound when slope of machine exceeds 3° side to side, or fore and aft.	Lower control box, exterior upper left side. Operated by the white wire.	R11	Throttle Relay	Switches power to throttle solenoid.	Lower control box, second row, eleventh relay from left.
ALM 2	Alarm, Down	Provides warning sound when deck is lowering.	Lower control box, exterior upper left side. Operated by red wire.	R12	Choke Relay	Actuate Choke	Lower control box
ALT	Alternator	Maintains current during operation.	Power module, front left side of engine.	R13	Drive / Lift Relay	Directs power from forward (S3) and reverse (S2) switches to either forward / reverse or up / down relays.	Lower control box, first row, first relay from right.
BAT	Battery	Provides power for starting engine.	Control module. On left in rear of module.	R14	Drive Relay	Cuts power to forward and reverse relays when cutout relay is not energized and platform is elevated.	Lower control box, first row, second relay from left.
D1	Diode	Supplies power to down relay.	Between T10 and T11 on fanning strip.	R15	Cutout Relay	Cuts power to drive and up relays when not energized by level sensor.	Lower control box, first row, third relay from left.
D2	Diode	Supplies power to high speed enable circuit.	Between T16 and T17 on fanning strip.	R16	Platform Down Relay	Cuts power to series / parallel relay when platform is elevated, selecting high torque mode.	Lower control box, second row, first relay from left.
D3	Diode	Supplies power to high speed enable circuit.	Between T17 and T18 on fanning strip.	R17	Power Relay	Switches power to all solenoids and engine.	Lower control box, first row, fourth relay from left.
D4	Diode	Supplies power to Throttle Solenoid.	Between T18 and T19 on fanning strip.	R18	Ignition Relay	Enables Engine Start	Upper Controller
D5	Diode	Supplies power to power relay.	Lower control box by power relay.	RES1	Proportional Resistor	Limits current to proportional solenoid.	Lower control box.
D6	Diode	Supplies power to power relay.	Lower control box by power relay.	S1	Micro Switch	Supplies power to controller.	Upper control box, joystick.
D7	Diode	Supplies power to drive relay.	Lower control box by drive relay.	S2	Reverse Micro Switch	Supplies power to drive / lift relay, forward / up contacts.	Upper control box, joystick.
F1	Emergency Stop Circuit Breaker	Supplies Power to Upper Control Ignition Switch.	Lower control box mounted in panel, lower right hand.	S3	Forward Micro Switch	Supplies power to drive / lift relay, reverse / down contacts.	Upper control box, joystick.
F2	Power Circuit Breaker	Supplies power to all function solenoids.	Lower control box mounted in panel, lower left hand.	S4	Interlock Micro Switch (Deadman Switch)	Interrupts power to controls when not engaged.	Upper control box, inside joystick handle.
L1	Drive Enable Light	Indicates Drive Enabled	Upper control box	S5	Steering Micro Switch (two)	Supplies power to steer left and steer right relays.	Upper control box, inside joystick handle.
LS1	Down Limit Switch	Bypasses level sensor, supplying power to cutout relay when platform is lowered.	Under scissors, near front right hand side of chassis.	S6,7	Drive / Lift Switch	Supplies Power to steering micro switch (drive) or to drive / lift relay (lift).	Upper control box, to the right of joystick.
LS2	Down Limit Switch	Supplies power to drive and platform down relays, and high speed enable circuit on controller when platform is lowered.	Under scissors, near front right hand side of chassis.	S8	Torque Selector Switch	Supplies power to series / parallel relay.	Upper control box, to the right of joystick.
MOT1	Starter Motor, and Solenoid	Provides power to starter motor from battery.	Left side of engine, in power module.	S9	Ignition Switch	Supplies power to upper controls, engine, and starter motor solenoid.	Upper control box, right side.
PS1	Oil Pressure Switch	Cuts power to engine when oil pressure falls to dangerous level.	Left side of engine, in power module.	S10	Choke Switch	Actuates Choke	Upper control box
R1	Forward Relay	Switches power to forward solenoid.	Lower control box, second row, second relay from left.	S11	Emergency Stop Switch	Cuts power to upper controls and engine.	Upper control box, to the left of joystick.
R2	Reverse Relay	Switches power to reverse solenoid.	Lower control box, second row, third relay from left.	S12	Fuel Selector Switch	Selects LP/Gas	Lower control box
R3	Tilt Alarm Relay	Switches power to tilt alarm.	Lower control box, second row, fourth relay from left.	S13	Engine Stop Switch	Cuts power to ignition module, and fuel shut-off solenoid.	Lower control box, in panel second from top, second from right.
R4	Up Relay	Switches power to lift solenoid.	Lower control box, second row, fifth relay from left.	S14	Starter Switch	Starts Engine	Lower control box
R5	Series / Parallel Relay	Switches power to series / parallel solenoids.	Lower control box, second row, sixth relay from left.	S15	Emergency Stop Switch	Cuts power to lower controls and engine.	Lower control box, in panel, top, first from left.
R6	Axle Float Relay	Power to Axle Float Solenoid	Lower control box	S16	Chassis / Platform Switch	Supplies power to either upper or lower controls.	Lower control box, in panel, second from top, second from left.
R7	Down Relay	Switches power to down solenoid.	Lower control box, second row, seventh relay from left.	S17	Down Switch	Supplies power to down relay.	Lower control box, in panel, third from top, first from left.
R8	Down Alarm Relay	Switches power to down alarm.	Lower control box, second row, eighth relay from left.	S18	Lift Switch	Supplies power to up relay.	Lower control box, in panel, second from top, first from left.
R9	Steer Right Relay	Switches power to steer right solenoid.	Lower control box, second row, ninth relay from left.	S19	Throttle Switch	Supplies power to throttle relay.	Lower control box, in panel, top, first from right.
R10	Steer Left Relay	Switches power to steer left solenoid.	Lower control box, second row, tenth relay from left.	S20	Choke Switch	Actuate Choke	Lower control box
				S21	Ignition Switch	Power to Start Engine	Lower control box
				S22	Up Limit Switch	Cuts power to Up Solenoid	Chassis below lift Assembly
				S23	Axle Float Switch	Allows Axle Float	Lower control box



Table 6-4: (cont.)

REFERENCE DESIGNATION	NAME	FUNCTION	LOCATION
S23	Axle Float Switch	Allows Axle Float	Lower control box
SEN1	Level Sensor	Provides power to cutout relay when machine is level	Control module.
SOL1	Proportional Solenoid	Controls proportional valve.	Right side of manifold, port marked 'C'.
SOL2	Forward Solenoid	Controls forward valve.	Right side of valve manifold, port marked 'K'.
SOL3	Reverse Solenoid	Controls reverse valve.	Right side of manifold, port marked 'L'.
SOL4	Lift Solenoid.	Controls lift valve.	Right side of manifold, port marked 'J'.
SOL5	Series / Parallel Solenoid (two)	Controls series / parallel valves.	Front side of manifold, ports marked 'Q' & 'R'.
SOL6	Down Solenoid	Controls down valve.	Lift cylinder, lower end.
SOL7	Steer Right Solenoid	Controls steer valve when steering right.	Top of manifold, on steer valve.
SOL8	Steer Left Solenoid	Controls steer valve when steering left.	Top of manifold, on steer valve.
SOL9	LP Option Solenoid	Selects LP	Engine module
SOL10	Throttle Solenoid	Controls Engine Speed	Engine Module
SOL11	Choke Solenoid	Regulates Choke	Engine Module
SOL12	Shunt Solenoid	Allows bypass of excess oil from rear motors	Steering Valve Block
SOL13	Gasoline Solenoid	Selects Gas	Engine Module
SOL14	Axle Float Solenoid	Allows Axle Float	Lower control box

Note: See Figure 6-20 for relay, terminal strip locations.

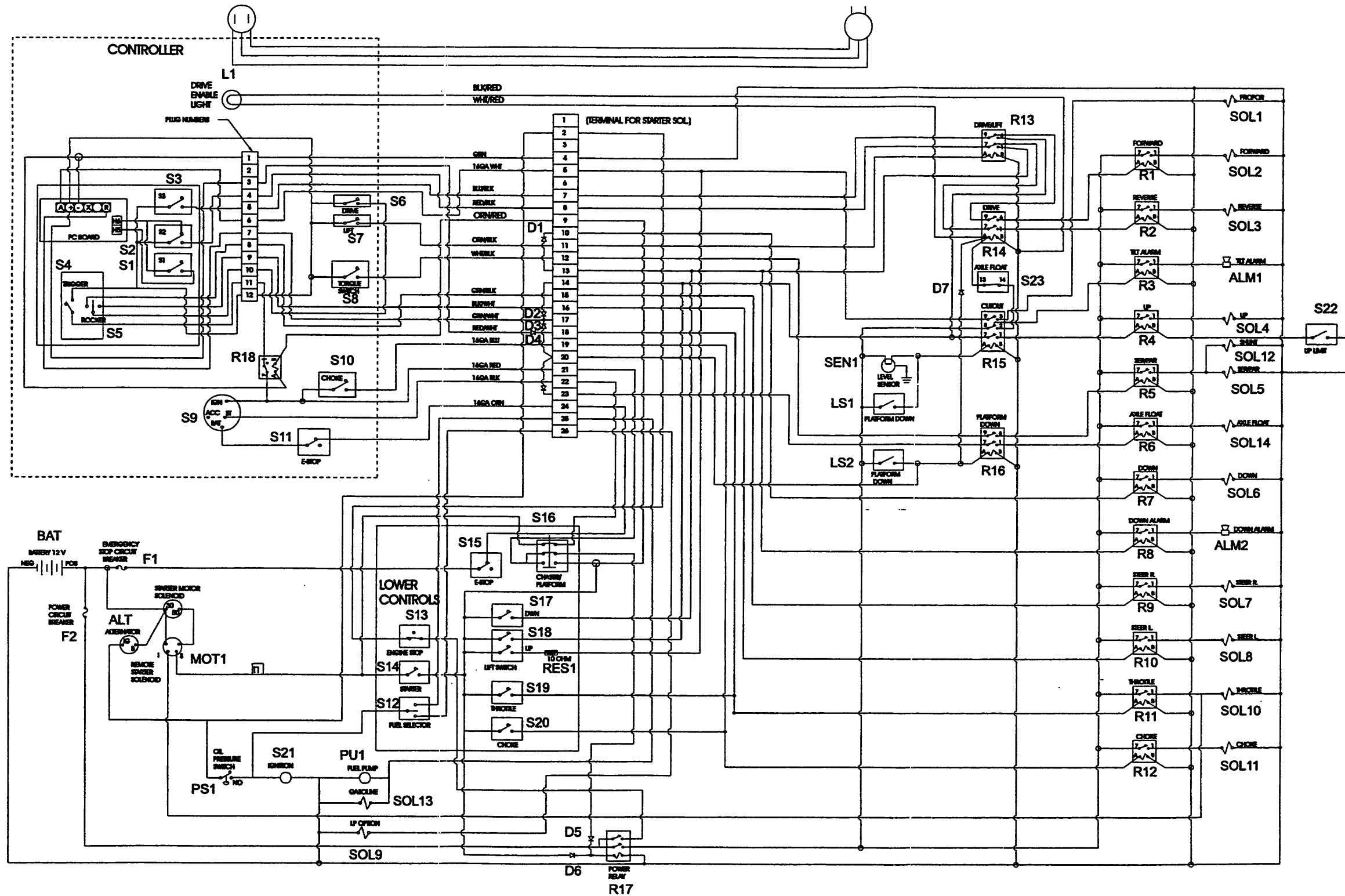

Figure 6-4: 067535-000 Four Wheel Drive, Gasoline Model

## 6.1 Electrical Schematics

Table 6-5: 067535-001 Four Wheel Drive, Diesel Model (S/N: 1330 - 2219)

REFERENCE DESIGNATION	NAME	FUNCTION	LOCATION
ALM 1	Alarm, Tilt	Provides warning sound when slope of machine exceeds 3° side to side, or fore and aft.	Lower control box, exterior upper left side. Operated by the white wire.
ALM 2	Alarm, Down	Provides warning sound when deck is lowering.	Lower control box, exterior upper left side. Operated by red wire.
ALT	Alternator	Maintains current during operation.	Power module, front left side of engine.
BAT	Battery	Provides power for starting engine.	Control module. On left in rear of module.
D1	Diode	Supplies power to down relay.	Between T10 and T11 on fanning strip.
D2	Diode	Supplies power to high speed enable circuit.	Between T16 and T17 on fanning strip.
D3	Diode	Supplies power to high speed enable circuit.	Between T17 and T18 on fanning strip.
D4	Diode	Supplies power to Down relay.	Between T18 and T19 on fanning strip.
D5	Diode	Supplies power to power relay.	Lower control box by power relay.
D6	Diode	Supplies power to power relay.	Lower control box by power relay.
D7	Diode	Supplies power to drive relay.	Lower control box by drive relay.
D8	Diode	Power to Axle Float Relay	Between T22 and T23
F1	Emergency Stop Circuit Breaker	Supplies Power to Upper Control Ignition Switch.	Lower control box mounted in panel, lower right hand.
F2	Power Circuit Breaker	Supplies power to all function solenoids.	Lower control box mounted in panel, lower left hand.
L1	Drive Enable Light	Indicates Drive Enabled	Upper control box
LS1	Down Limit Switch	Bypasses level sensor, supplying power to cutout relay when platform is lowered.	Under scissors, near front right hand side of chassis.
LS2	Down Limit Switch	Supplies power to drive and platform down relays, and high speed enable circuit on controller when platform is lowered.	Under scissors, near front right hand side of chassis.
MOT1	Starter Motor, and Solenoid	Provides power to starter motor from battery.	Left side of engine, in power module.
PS1	Oil Pressure Switch	Cuts power to engine when oil pressure falls to dangerous level.	Left side of engine, in power module.
R1	Forward Relay	Switches power to forward solenoid.	Lower control box, second row, second relay from left.
R2	Reverse Relay	Switches power to reverse solenoid.	Lower control box, second row, third relay from left.
R3	Tilt Alarm Relay	Switches power to tilt alarm.	Lower control box, second row, fourth relay from left.
R4	Up Relay	Switches power to lift solenoid.	Lower control box, second row, fifth relay from left.
R5	Series / Parallel Relay	Switches power to series / parallel solenoids.	Lower control box, second row, sixth relay from left.
R6	Glow Plug Relay	Power to Glow Plugs	Lower control box
R7	Down Relay	Switches power to down solenoid.	Lower control box, second row, seventh relay from left.
R8	Down Alarm Relay	Switches power to down alarm.	Lower control box, second row, eighth relay from left.
R9	Steer Right Relay	Switches power to steer right solenoid.	Lower control box, second row, ninth relay from left.
R10	Steer Left Relay	Switches power to steer left solenoid.	Lower control box, second row, tenth relay from left.

REFERENCE DESIGNATION	NAME	FUNCTION	LOCATION
R11	Throttle Relay	Switches power to throttle solenoid.	Lower control box, second row, eleventh relay from left.
R12	Axle Float Relay	Power to Axle Float Solenoid	Lower control box
R13	Drive / Lift Relay	Directs power from forward (S3) and reverse (S2) switches to either forward / reverse or up / down relays.	Lower control box, first row, first relay from right.
R14	Drive Relay	Cuts power to forward and reverse relays when cutout relay is not energized and platform is elevated.	Lower control box, first row, second relay from left.
R15	Cutout Relay	Cuts power to drive and up relays when not energized by level sensor.	Lower control box, first row, third relay from left.
R16	Platform Down Relay	Cuts power to series / parallel relay when platform is elevated, selecting high torque mode.	Lower control box, second row, first relay from left.
R17	Power Relay	Switches power to all solenoids and engine.	Lower control box, first row, fourth relay from left.
R18	Starter Relay	Switches power to starter.	Power module, engine assembly.
R19	Ignition Relay	Enables Engine Start	Upper Controller
R20	Bosch Throttle Relay	Controls Engine Speed	Engine Module
RES1	Proportional Resistor	Limits current to proportional solenoid.	Lower control box.
RES2	Glow Plugs	Used when starting cold engine.	Diesel engine cylinder head.
S1	Micro Switch	Supplies power to controller.	Upper control box, joystick.
S2	Reverse Micro Switch	Supplies power to drive / lift relay, forward / up contacts.	Upper control box, joystick.
S3	Forward Micro Switch	Supplies power to drive / lift relay, reverse / down contacts.	Upper control box, joystick.
S4	Interlock Micro Switch (Deadman Switch)	Interrupts power to controls when not engaged.	Upper control box, inside joystick handle.
S5	Steering Micro Switch (two)	Supplies power to steer left and steer right relays.	Upper control box, inside joystick handle.
S6,7	Drive / Lift Switch	Supplies Power to steering micro switch (drive) or to drive / lift relay (lift).	Upper control box, to the right of joystick.
S8	Torque Selector Switch	Supplies power to series / parallel relay.	Upper control box, to the right of joystick.
S9	Ignition Switch	Supplies power to upper controls, engine, and starter motor solenoid.	Upper control box, right side.
S10	Glow Plug Switch	Supplies power to glow plug relay.	Upper control box, left side.
S11	Emergency Stop Switch	Cuts power to upper controls and engine.	Upper control box, to the left of joystick.
S12	Engine Stop Switch	Cuts power to ignition module, and fuel shut-off solenoid.	Lower control box, in panel second from top, second from right.
S13	Starter Switch	Supplies power to starter motor solenoid.	Lower control box, in panel, top, second from right.
S15	Emergency Stop Switch	Cuts power to lower controls and engine.	Lower control box, in panel, top, first from left.
S16	Chassis / Platform Switch	Supplies power to either upper or lower controls.	Lower control box, in panel, second from top, second from left.
S17	Down Switch	Supplies power to down relay.	Lower control box, in panel, third from top, first from left.

Table 6-5: (cont.)

REFERENCE DESIGNATION	NAME	FUNCTION	LOCATION
S18	Lift Switch	Supplies Power to up Relay	Lower control box
S19	Throttle Switch	Supplies Power to Throttle relay	Lower control box
S20	Glow Plug Switch	Power to Glow Plug Relay	Lower control box
S21	Up Limit Switch	Prevents Full extension of Lift Cylinders	Lower control box
SEN1	Level Sensor	Provides power to cutout relay when machine is level	Control module.
SOL1	Proportional Solenoid	Controls proportional valve.	Right side of manifold, port marked 'G'.
SOL2	Forward Solenoid	Controls forward valve.	Right side of valve manifold, port marked 'K'.
SOL3	Reverse Solenoid	Controls reverse valve.	Right side of manifold, port marked 'L'.
SOL4	Lift Solenoid.	Controls lift valve.	Right side of manifold, port marked 'J'.
SOL5	Series / Parallel Solenoid (two)	Controls series / parallel valves.	Front side of manifold, ports marked 'Q' & 'R'.
SOL6	Down Solenoid	Controls down valve.	Lift cylinder, lower end.
SOL7	Steer Right Solenoid	Controls steer valve when steering right.	Top of manifold, on steer valve.
SOL8	Steer Left Solenoid	Controls steer valve when steering left.	Top of manifold, on steer valve.
SOL9	Run Solenoid	Enables Engine Operation	Engine module
SOL10	Shunt Solenoid	Allows Bypass of Excess oil from Rear Motors	Steering Valve Block
SOL11	Axle Float Solenoid	Allows Axle Float	Lower control box
SOL12	Throttle Solenoid	Controls Engine Speed	Engine Module

Note: See Figure 6-20 for relay, terminal strip locations.

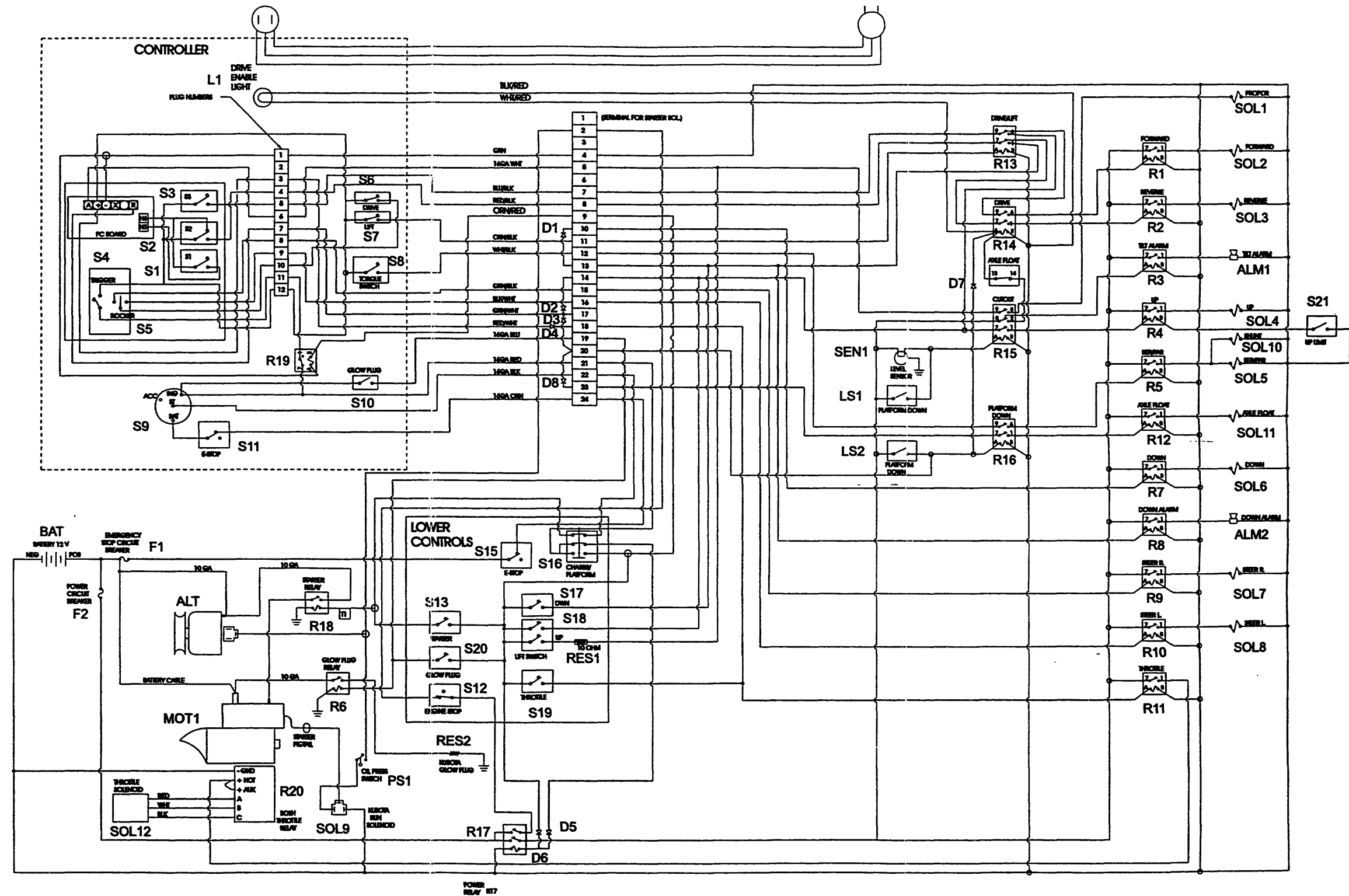

Figure 6-5: 067535-001 Four Wheel Drive, Diesel (Serial Numbers 1331 - 2219)

## 6.1 Electrical Schematics

Table 6-6: 067535-001 Four Wheel Drive, Diesel Model (S/N: 2219 - Current)

REFERENCE DESIGNATION	NAME	FUNCTION	LOCATION
ALM 1	Alarm, Tilt	Provides warning sound when slope of machine exceeds 3° side to side, or fore and aft.	Lower control box, exterior upper left side. Operated by the white wire.
ALM 2	Alarm, Down	Provides warning sound when deck is lowering.	Lower control box, exterior upper left side. Operated by red wire.
ALT	Alternator	Maintains current during operation.	Power module, front left side of engine.
BAT	Battery	Provides power for starting engine.	Control module. On left in rear of module.
D1	Diode	Supplies power to down relay.	Between T10 and T11 on fanning strip.
D2	Diode	Supplies power to high speed enable circuit.	Between T16 and T17 on fanning strip.
D3	Diode	Supplies power to high speed enable circuit.	Between T17 and T18 on fanning strip.
D4	Diode	Supplies power to Throttle Solenoid.	Between T18 and T19 on fanning strip.
D5	Diode	Supplies power to power relay.	Lower control box by power relay.
D6	Diode	Supplies power to power relay.	Lower control box by power relay.
D7	Diode	Supplies power to drive relay.	Lower control box by drive relay.
D8	Diode	Power to Axle Float Relay	Lower control box
F1	Emergency Stop Circuit Breaker	Supplies Power to Upper Control Ignition Switch.	Lower control box mounted in panel, lower right hand.
F2	Power Circuit Breaker	Supplies power to all function solenoids.	Lower control box mounted in panel, lower left hand.
L1	Drive Enable Light	Indicates Drive Enabled	Upper control box
LS1	Down Limit Switch	Bypasses level sensor, supplying power to cutout relay when platform is lowered.	Under scissors, near front right hand side of chassis.
LS2	Down Limit Switch	Supplies power to drive and platform down relays, and high speed enable circuit on controller when platform is lowered.	Under scissors, near front right hand side of chassis.
MOT1	Starter Motor, and Solenoid	Provides power to starter motor from battery.	Left side of engine, in power module.
PS1	Oil Pressure Switch	Cuts power to engine when oil pressure falls to dangerous level.	Left side of engine, in power module.
R1	Forward Relay	Switches power to forward solenoid.	Lower control box, second row, second relay from left.
R2	Reverse Relay	Switches power to reverse solenoid.	Lower control box, second row, third relay from left.
R3	Tilt Alarm Relay	Switches power to tilt alarm.	Lower control box, second row, fourth relay from left.
R4	Up Relay	Switches power to lift solenoid.	Lower control box, second row, fifth relay from left.
R5	Series / Parallel Relay	Switches power to series / parallel solenoids.	Lower control box, second row, sixth relay from left.
R6	Glow Plug Relay	Power to Glow Plugs	Lower control box
R7	Down Relay	Switches power to down solenoid.	Lower control box, second row, seventh relay from left.
R8	Down Alarm Relay	Switches power to down alarm.	Lower control box, second row, eighth relay from left.
R9	Steer Right Relay	Switches power to steer right solenoid.	Lower control box, second row, ninth relay from left.
R10	Steer Left Relay	Switches power to steer left solenoid.	Lower control box, second row, tenth relay from left.

REFERENCE DESIGNATION	NAME	FUNCTION	LOCATION
R11	Throttle Relay	Switches power to throttle solenoid.	Lower control box, second row, eleventh relay from left.
R12	Axle Float Relay	Power to Axle Float Solenoid	Lower control box
R13	Drive / Lift Relay	Directs power from forward (S3) and reverse (S2) switches to either forward / reverse or up / down relays.	Lower control box, first row, first relay from right.
R14	Drive Relay	Cuts power to forward and reverse relays when cutout relay is not energized and platform is elevated.	Lower control box, first row, second relay from left.
R15	Cutout Relay	Cuts power to drive and up relays when not energized by level sensor.	Lower control box, first row, third relay from left.
R16	Platform Down Relay	Cuts power to series / parallel relay when platform is elevated, selecting high torque mode.	Lower control box, second row, first relay from left.
R17	Power Relay	Switches power to all solenoids and engine.	Lower control box, first row, fourth relay from left.
R18	Starter Relay	Switches power to starter.	Power module, engine assembly.
R19	Ignition Relay	Enables Engine Start	Upper Controller
RES1	Proportional Resistor	Limits current to proportional solenoid.	Lower control box.
RES2	Glow Plugs	Used when starting cold engine.	Diesel engine cylinder head.
S1	Micro Switch	Supplies power to controller.	Upper control box, joystick.
S2	Reverse Micro Switch	Supplies power to drive / lift relay, forward / up contacts.	Upper control box, joystick.
S3	Forward Micro Switch	Supplies power to drive / lift relay, reverse / down contacts.	Upper control box, joystick.
S4	Interlock Micro Switch (Deadman Switch)	Interrupts power to controls when not engaged.	Upper control box, inside joystick handle.
S5	Steering Micro Switch	Supplies power to steer left and steer right relays.	Upper control box, inside joystick handle.
S6,7	Drive / Lift Switch	Supplies Power to steering micro switch (drive) or to drive / lift relay (lift).	Upper control box, to the right of joystick.
S8	Torque Selector Switch	Supplies power to series / parallel relay.	Upper control box, to the right of joystick.
S9	Ignition Switch	Supplies power to upper controls, engine, and starter motor solenoid.	Upper control box, right side.
S10	Glow Plug Switch	Supplies power to glow plug relay.	Upper control box, left side.
S11	Emergency Stop Switch	Cuts power to upper controls and engine.	Upper control box, to the left of joystick.
S12	Engine Stop Switch	Cuts power to ignition module, and fuel shut-off solenoid.	Lower control box, in panel second from top, second from right.
S13	Starter Switch	Supplies power to starter motor solenoid.	Lower control box, in panel, top, second from right.
S15	Emergency Stop Switch	Cuts power to lower controls and engine.	Lower control box, in panel, top, first from left.
S16	Chassis / Platform Switch	Supplies power to either upper or lower controls.	Lower control box, in panel, second from top, second from left.
S17	Down Switch	Supplies power to down relay.	Lower control box, in panel, third from top, first from left.

Table 6-6: (cont.)

REFERENCE DESIGNATION	NAME	FUNCTION	LOCATION
S18	Lift Switch	Supplies Power to up Relay	Lower control box
S19	Throttle Switch	Supplies Power to Throttle relay	Lower control box
S20	Glow Plug Switch	Power to Glow Plug Relay	Lower control box
S21	Up Limit Switch	Prevents Full extension of Lift Cylinders	Lower control box
SEN1	Level Sensor	Provides power to cutout relay when machine is level	Control module.
SOL1	Proportional Solenoid	Controls proportional valve.	Right side of manifold, port marked 'G'.
SOL2	Forward Solenoid	Controls forward valve.	Right side of valve manifold, port marked 'K'.
SOL3	Reverse Solenoid	Controls reverse valve.	Right side of manifold, port marked 'L'.
SOL4	Lift Solenoid.	Controls lift valve.	Right side of manifold, port marked 'J'.
SOL5	Series / Parallel Solenoid (two)	Controls series / parallel valves.	Front side of manifold, ports marked 'Q' & 'R'.
SOL6	Down Solenoid	Controls down valve.	Lift cylinder, lower end.
SOL7	Steer Right Solenoid	Controls steer valve when steering right.	Top of manifold, on steer valve.
SOL8	Steer Left Solenoid	Controls steer valve when steering left.	Top of manifold, on steer valve.
SOL9	Run Solenoid	Enables Engine Operation	Engine module
SOL10	Shunt Solenoid	Allows Bypass of Excess from Rear Motors	Steering Valve Block
SOL11	Axle Float Solenoid	Allows Axle Float	Lower control box
SOL12	Throttle Solenoid	Controls Engine Speed	Engine Module

Note: See Figure 6-20 for relay, terminal strip locations.

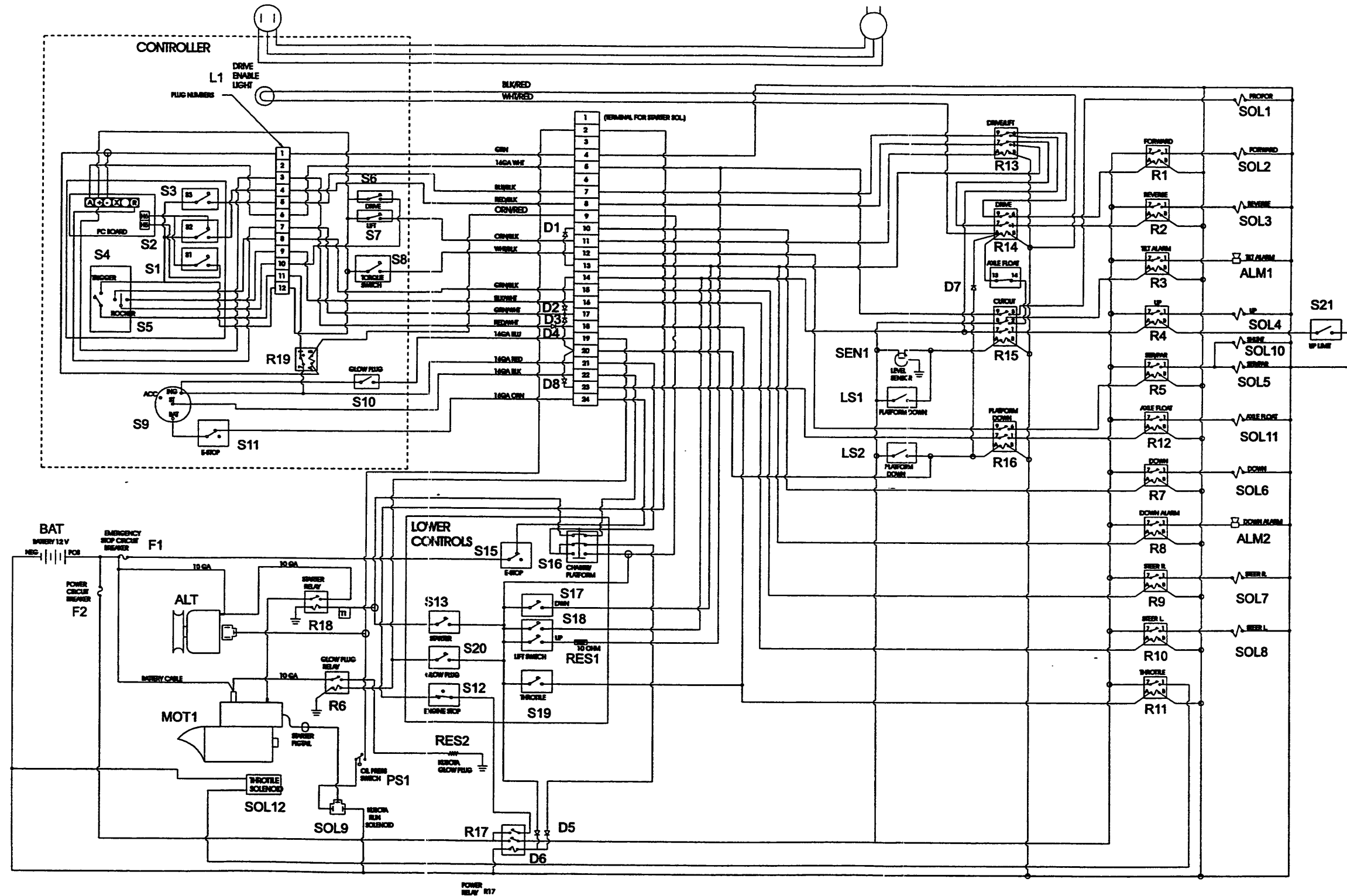

Figure 6-6: Electrical Schematic, Four Wheel Drive, Diesel Model (Serial Number 2219 - Current)

## 6.1 Electrical Schematics

Table 6-7: 067535-027 Two Wheel Drive, Gasoline Dual Deck Model with Outriggers

REFERENCE DESIGNATION	NAME	FUNCTION	LOCATION
ALM 1	Alarm, Tilt	Provides warning sound when slope of machine exceeds 3° side to side, or fore and aft.	Lower control box, exterior upper left side. Operated by the white wire.
ALM 2	Alarm, Down	Provides warning sound when deck is lowering.	Lower control box, exterior upper left side. Operated by red wire.
ALT	Alternator	Maintains current during operation.	Power module, front left side of engine.
BAT	Battery	Provides power for starting engine.	Control module. On left in rear of module.
D1	Diode	Supplies power to down relay.	Between T10 and T11 on fanning strip.
D2	Diode	Supplies power to high speed enable circuit.	Between T16 and T17 on fanning strip.
D3	Diode	Supplies power to high speed enable circuit.	Between T17 and T18 on fanning strip.
D4	Diode	Supplies power to Throttle Solenoid.	Between T18 and T19 on fanning strip.
D5	Diode	Supplies power to power relay.	Lower control box by power relay.
D6	Diode	Supplies power to power relay.	Lower control box by power relay.
D7	Diode	Supplies power to drive relay.	Lower control box by drive relay.
F1	Emergency Stop Circuit Breaker	Supplies Power to Upper Control Ignition Switch.	Lower control box mounted in panel, lower right hand.
F2	Power Circuit Breaker	Supplies power to all function solenoids.	Lower control box mounted in panel, lower left hand.
L1	Drive Enable Light	Indicates Drive Enabled	Platform control box
LS1	Down Limit Switch	Bypasses level sensor, supplying power to cutout relay when platform is lowered.	Under scissors, near front right hand side of chassis.
LS2	Down Limit Switch	Supplies power to drive and platform down relays, and high speed enable circuit on controller when platform is lowered.	Under scissors, near front right hand side of chassis.
MOD1	Ignition Module	Controls spark for engine.	Right side of engine, in power module.
MOT1	Starter Motor, and Solenoid	Provides power to starter motor from battery.	Left side of engine, in power module.
PS1	Oil Pressure Switch	Cuts power to engine when oil pressure falls to dangerous level.	Left side of engine, in power module.
PS2	Oil Pressure Switch	Lift/Interlock Pressure Switches	Outrigger Valve Block
PU1	Electric Fuel Pump	Supplies fuel to engine.	Top rear of engine, in power module.
R1	Forward Relay	Switches power to forward solenoid.	Lower control box, second row, second relay from left.
R2	Reverse Relay	Switches power to reverse solenoid.	Lower control box, second row, third relay from left.
R3	Tilt Alarm Relay	Switches power to tilt alarm.	Lower control box, second row, fourth relay from left.
R4	Up Relay	Switches power to lift solenoid.	Lower control box, second row, fifth relay from left.
R5	Series / Parallel Relay	Switches power to series / parallel solenoids.	Lower control box, second row, sixth relay from left.
R6	Power Relay	Switches power to all solenoids and engine.	Lower control box, first row, fourth relay from left.
R7	Down Relay	Switches power to down solenoid.	Lower control box, second row, seventh relay from left.

REFERENCE DESIGNATION	NAME	FUNCTION	LOCATION
R8	Down Alarm Relay	Switches power to down alarm.	Lower control box, second row, eighth relay from left.
R9	Steer Right Relay	Switches power to steer right solenoid.	Lower control box, second row, ninth relay from left.
R10	Steer Left Relay	Switches power to steer left solenoid.	Lower control box, second row, tenth relay from left.
R11	Throttle Relay	Switches power to throttle solenoid.	Lower control box, second row, eleventh relay from left.
R12	Choke Relay	Switches power to choke solenoid.	Lower control box, second row, twelfth relay from left.
R13	Drive / Lift Relay	Directs power from forward (S3) and reverse (S2) switches to either forward / reverse or up / down relays.	Lower control box, first row, first relay from right.
R14	Drive Relay	Cuts power to forward and reverse relays when cutout relay is not energized and platform is elevated.	Lower control box, first row, second relay from left.
R15	Cutout Relay	Cuts power to drive and up relays when not energized by level sensor.	Lower control box, first row, third relay from left.
R16	Platform Down Relay	Cuts power to series / parallel relay when platform is elevated, selecting high torque mode.	Lower control box, second row, first relay from left.
R17	Ignition Relay	Power to Platform Ignition Switch	Upper control box.
R18-R25	Outrigger Extend/Retract Relays	Power to Extend/Retract Relays	Lower control box
R26, 27	Pressure Switch Override Relays	Override Pressure Switches	Lower control box
RES1	Proportional Resistor	Limits current to proportional solenoid.	Lower control box.
S1	Micro Switch	Supplies power to controller.	Upper control box, joystick.
S2	Reverse Micro Switch	Supplies power to drive / lift relay, forward / up contacts.	Upper control box, joystick.
S3	Forward Micro Switch	Supplies power to drive / lift relay, reverse / down contacts.	Upper control box, joystick.
S4	Interlock Micro Switch (Deadman Switch)	Interrupts power to controls when not engaged.	Upper control box, inside joystick handle.
S5	Steering Micro Switch (two)	Supplies power to steer left and steer right relays.	Upper control box, inside joystick handle.
S6,7	Drive / Lift Switch	Supplies Power to steering micro switch (drive) or to drive / lift relay (lift).	Upper control box, to the right of joystick.
S8	Torque Selector Switch	Supplies power to series / parallel relay.	Upper control box, to the right of joystick.
S9	Ignition Switch	Supplies power to upper controls, engine, and starter motor solenoid.	Upper control box, right side.
S10	Choke Switch	Supplies power to choke relay.	Upper control box, left side.
S11	Emergency Stop Switch	Cuts power to upper controls and engine.	Upper control box, to the left of joystick.
S12	Engine Stop Switch	Cuts power to ignition module, and fuel shut-off solenoid.	Lower control box, in panel second from top, second from right.

Table 6-7: (cont.)

REFERENCE DESIGNATION	NAME	FUNCTION	LOCATION
S13	Starter Switch	Supplies power to starter motor solenoid	Lower control box, in panel, top, second from right
S14	Fuel Selector Switch	Selects LP or Gas	Engine Module
S15	Emergency Stop Switch	Cuts power to lower controls and engine	Lower control box, in panel, top, first from left.
S16	Chassis - Platform Switch	Supplies power to either upper or lower controls.	Lower control box, in panel, second from top, second from left.
S17	Down Switch	Supplies power to down relay.	Lower control box, in panel, third from top, first from left.
S18	Raise Switch	Raise Platform	Lower control box
S19	Throttle Switch	Supplies power to throttle relay	Lower control box, in panel, top, first from right.
S20	Choke Switch	Supplies power to choke relay.	Lower control box, in panel, second from top, first from right.
S21	Up Limit Switch	Limit cylinder extension	Chassis
S22	40" Limit Switch	40" travel limit switch	Chassis
SEN1	Level Sensor	Provides power to cutout relay when machine is level.	Control module.
SOL1	Throttle Solenoid	Controls engine throttle.	Power module, engine, right side.
SOL2	Fuel Shut Off Solenoid	Controls fuel valve.	Engine Module
SOL3	Gas Solenoid	Controls Fuel Valve.	Power module, inline with gasoline supply.
SOL4	Propane Shut-Off Solenoid	Controls propane valve.	Power module, inline propane supply.
SOL5	Proportional Solenoid	Controls proportional valve.	Right side of manifold, port marked 'C'.
SOL6	Forward Solenoid	Controls forward valve.	Right side of valve manifold, port marked 'K'
SOL7	Reverse Solenoid	Controls reverse valve.	Right side of manifold, port marked 'L'
SOL8	Lift Solenoid	Controls lift valve.	Right side of manifold, port marked 'J'.
SOL9	Remote Starter Solenoid	Start Engine	Engine Module
SOL10	Series / Parallel Solenoid (two)	Controls series / parallel valves.	Front side of manifold, ports marked 'Q' & 'R'.
SOL11	Choke Solenoid	Controls engine choke.	Power module, engine, right side.
SOL12	Down Solenoid	Controls down valve.	Lift cylinder, lower end.
SOL13	Steer Right Solenoid	Controls steer valve when steering right.	Top of manifold, on steer valve.
SOL14	Steer Left Solenoid	Controls steer valve when steering left	Top of manifold, on steer valve
SOL15-22	Outrigger Extend/Retract Solenoids	Extend/Retract Solenoids	Outrigger Valve Block

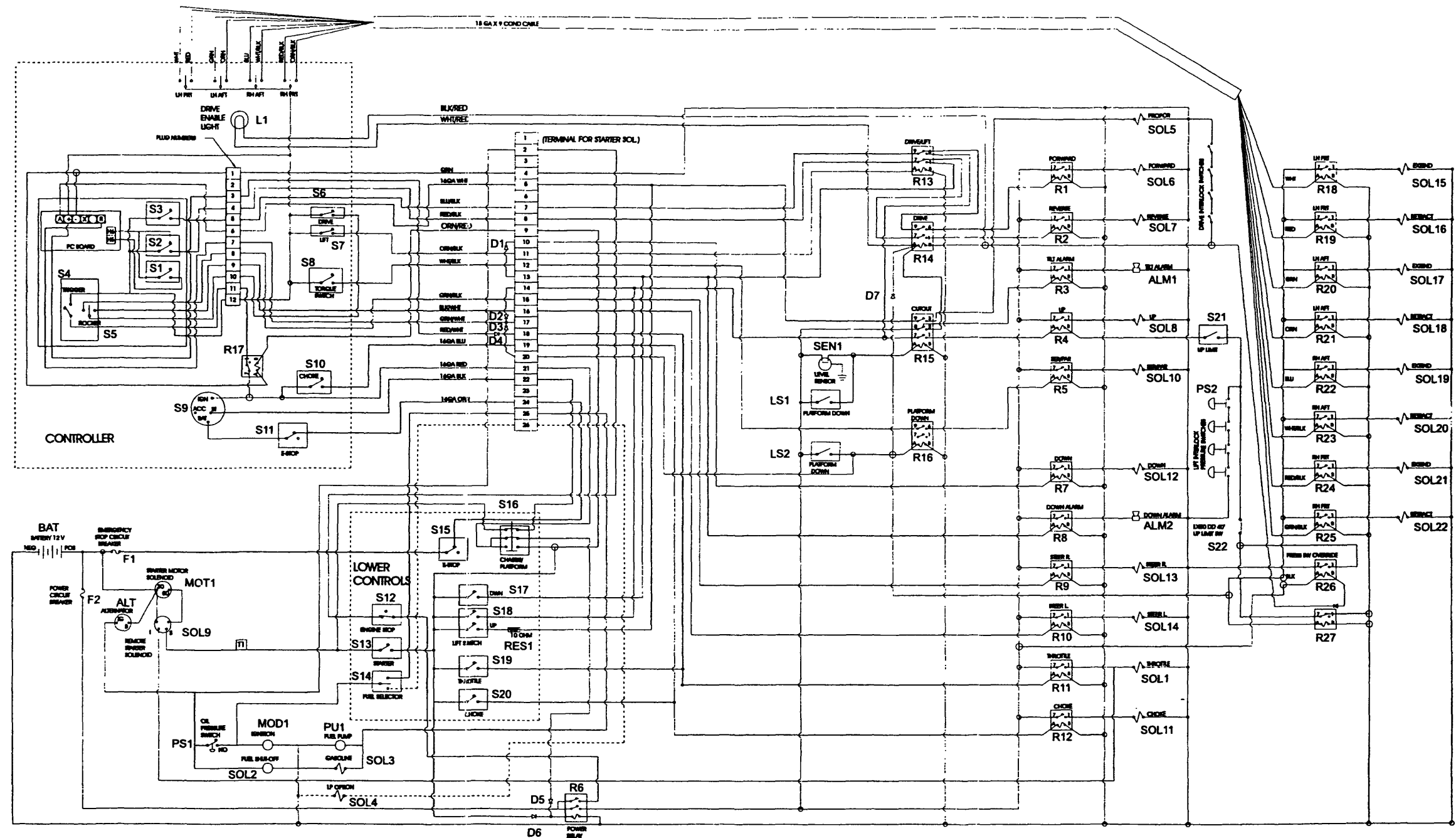

Note: See Figure 6-20 for relay, terminal strip locations.

Figure 6-7: 067535-027 - 2WD Gasoline Dual Deck with Outriggers

## 6.1 Electrical Schematics

Table 6-8: 067535-026 Two Wheel Drive, Diesel Dual Deck Model with Outriggers

REFERENCE DESIGNATION	NAME	FUNCTION	LOCATION
ALM 1	Tilt Alarm	Provides warning sound when slope of machine exceeds 3° side to side, or tore and ait	Lower control box, exterior upper left side Operated by the white wire
ALM 2	Down Alarm	Provides warning sound when deck is lowering	Lower control box, exterior upper left side Operated by red wire
ALT	Alternator	Maintains current during operation.	Power module, front left side of engine.
BAT	Battery	Provides power for starting engine	Control module. On left in rear of module
D1	Diode	Supplies power to down relay	Between T10 and T11 on fanning strip
D2	Diode	Supplies power to high speed enable circuit	Between T16 and T17 on fanning strip
D3	Diode	Supplies power to high speed enable circuit.	Between T17 and T18 on fanning strip
D4	Diode	Supplies power to Throttle Solinoid.	Between T18 and T19 on fanning strip.
D5	Diode	Supplies power to power relay	Lower control box by power relay
D6	Diode	Supplies power to power relay.	Lower control box by power relay
D7	Diode	Supplies power to drive relay.	Lower control box by drive relay
D8	Diode	Power to Axle Float Relay	Lower control box
F1	Emergency Stop Circuit Breaker	Supplies Power to Upper Control Igniton Switch	Lower control box mounted in panel, lower right hand
F2	Power Circuit Breaker	Supplies power to all function solenoids.	Lower control box mounted in panel, lower left hand
L1	Drive Enable Light	Indicates Drive Enabled	Platform control box
LS1	Down Limit Switch	Bypasses level sensor, supplying power to cutout relay when platform is lowered.	Under scissors, near front right hand side of chassis.
LS2	Down Limit Switch	Supplies power to drive and platform down relays, and high speed enable circuit on controller when platform is lowered	Under scissors, near front right hand side of chassis
MOT1	Starter Motor, and Solenoid	Provides power to starter motor from battery.	Left side of engine, in power module.
PS1	Oil Pressure Switch	Cuts power to engine when oil pressure falls to dangerous level.	Left side of engine, in power module.
PS2	Oil Pressure Switch	Lift/Interlock Pressure Switches	Outrigger Valve Block
R1	Forward Relay	Switches power to forward solenoid.	Lower control box, second row, second relay from left.
R2	Reverse Relay	Switches power to reverse solenoid.	Lower control box, second row, third relay from left
R3	Tilt Alarm Relay	Switches power to tilt alarm.	Lower control box, second row, fourth relay from left
R4	Lip Relay	Switches power to lift solenoid.	Lower control box, second row, fifth relay from left.
R5	Series / Parallel Relay	Switches power to series / parallel solenoids	Lower control box, second row, sixth relay from left
R6	Power Relay	Switches power to all solenoids and engine	Lower control box, first row, fourth relay from left.
R7	Down Relay	Switches power to down solenoid	Lower control box, second row, seventh relay from left

REFERENCE DESIGNATION	NAME	FUNCTION	LOCATION
R8	Down Alarm Relay	Switches power to down alarm	Lower control box, second row, eighth relay from left
R9	Steer Right Relay	Switches power to steer right solenoid	Lower control box second row, ninth relay from left
R10	Steer Left Relay	Switches power to steer left solenoid	Lower control box, second row, tenth relay from left
R11	Throttle Relay	Switches power to throttle solenoid	Lower control box, second row, eleventh relay from left
R12	Glow Plug Relay	Power to Glow Plug	Lower control box
R13	Drive / Lift Relay	Directs power from forward (S3) and reverse (S2) switches to either forward reverse or up / down relays	Lower control box, first row, first relay from right.
R14	Drive Relay	Cuts power to forward and reverse relays when cutout relay is not energized and platform is elevated	Lower control box, first row, second relay from left.
R15	Cutout Relay	Cuts power to drive and up relays when not energized by level sensor	Lower control box, first row, third relay from left
R16	Platform Down Relay	Cuts power to series / parallel relay when platform is elevated, selecting high torque mode	Lower control box, second row, first relay from left
R17	Ignition Relay	Power to Platform Ignition Switch	Upper control box.
R18-R25	Outrigger Extend/Retract Relays	Power to Extend/Retract Relays	Lower control box
R26, 27	Pressure Switch Override Relays	Override Pressure Switches	Lower control box
R28	Throttle Relay	Controls Engine operation	Engine Module
R29	Starter Relay	Start Engine	Lower control box
RES1	Proportional Resistor	Limits current to proportional solenoid	Lower control box.
RES2	Glow Plug	Heat to start engine	Engine
S1	Micro Switch	Supplies power to controller.	Upper control box, joystick
S2	Reverse Micro Switch	Supplies power to drive lift relay, forward up contacts	Upper control box, joystick
S3	Forward Micro Switch	Supplies power to drive lift relay, reverse / down contacts.	Upper control box, joystick
S4	Interlock Micro Switch (Deadman Switch)	Interrupts power to controls when not engaged.	Upper control box, inside joystick handle.
S5	Steering Micro Switch (two)	Supplies power to steer left and steer right relays.	Upper control box inside joystick handle
S6,7	Drive / Lift Switch	Supplies Power to steering micro switch (drive) or to drive / lift relay (lift).	Upper control box, to the right of joystick.
S8	Torque Selector Switch	Supplies power to series / parallel relay.	Upper control box, to the right of joystick.
S9	Ignition Switch	Supplies power to upper controls, engine, and starter motor solenoid	Upper control box, right side.
S10	Glow Plug Switch	Supplies power to glow plug relay.	Engine Module
S11	Emergency Stop Switch	Cuts power to upper controls and engine	Upper control box, to the left of joystick.



Table 6-8: (cont.)

REFERENCE DESIGNATION	NAME	FUNCTION	LOCATION
S12	Starter Switch	Supplies power to starter motor solenoid	Lower control box, in panel, top, second from right
S13			
S14	Engine Stop Switch	Selects LP or Gas	Engine Module
S15	Emergency Stop Switch	Cuts power to engine.	Lower control box, in panel, top, first from left
S16	Chassis / Platform Switch	Supplies power to either upper or lower controls	Lower control box, in panel, second from top, second from left
S17	Down Switch	Supplies power to down relay.	Lower control box, in panel, third from top, first from left.
S18	Raise Switch	Raise Platform	Lower control box
S20	Throttle Switch	Supplies power to throttle relay.	Lower control box, in panel, top, first from right.
S21	40' Limit Switch	40' travel Limit Switch	Chassis
S22	Up Limit Switch	Limits Lift Cylinder Extension	Chassis
S23	Drive Interlock Switches	Allow Machine to be Driven when Outriggers are Retracted	Outriggers
SEN1	Level Sensor	Provides power to cutout relay when machine is level.	Control module
SOL2	Throttle Solenoid	Controls engine throttle	Power module, engine, right side
SOL3	Run Solenoid	Allows Engine Run with proper Oil Pressure	Engine
SOL5	Proportional Solenoid	Controls proportional valve	Right side of manifold, port marked 'G'.
SOL6	Forward Solenoid	Controls forward valve.	Right side of valve manifold, port marked 'K'
SOL7	Reverse Solenoid	Controls reverse valve	Right side of manifold, port marked 'L'.
SOL8	Lift Solenoid	Controls lift valve.	Right side of manifold, port marked 'J'
SOL10	Series / Parallel Solenoid (two)	Controls series / parallel valves.	Front side of manifold, ports marked 'Q' & 'R'
SOL12	Down Solenoid	Controls down valve	Lift cylinder, lower end.
SOL13	Steer Right Solenoid	Controls steer valve when steering right	Top of manifold, on steer valve.
SOL14	Steer Left Solenoid	Controls steer valve when steering left.	Top of manifold, on steer valve.
SOL15-22	Outrigger Extend/Retract Solenoids	Extend/Retract Solenoids	Outrigger Valve Block

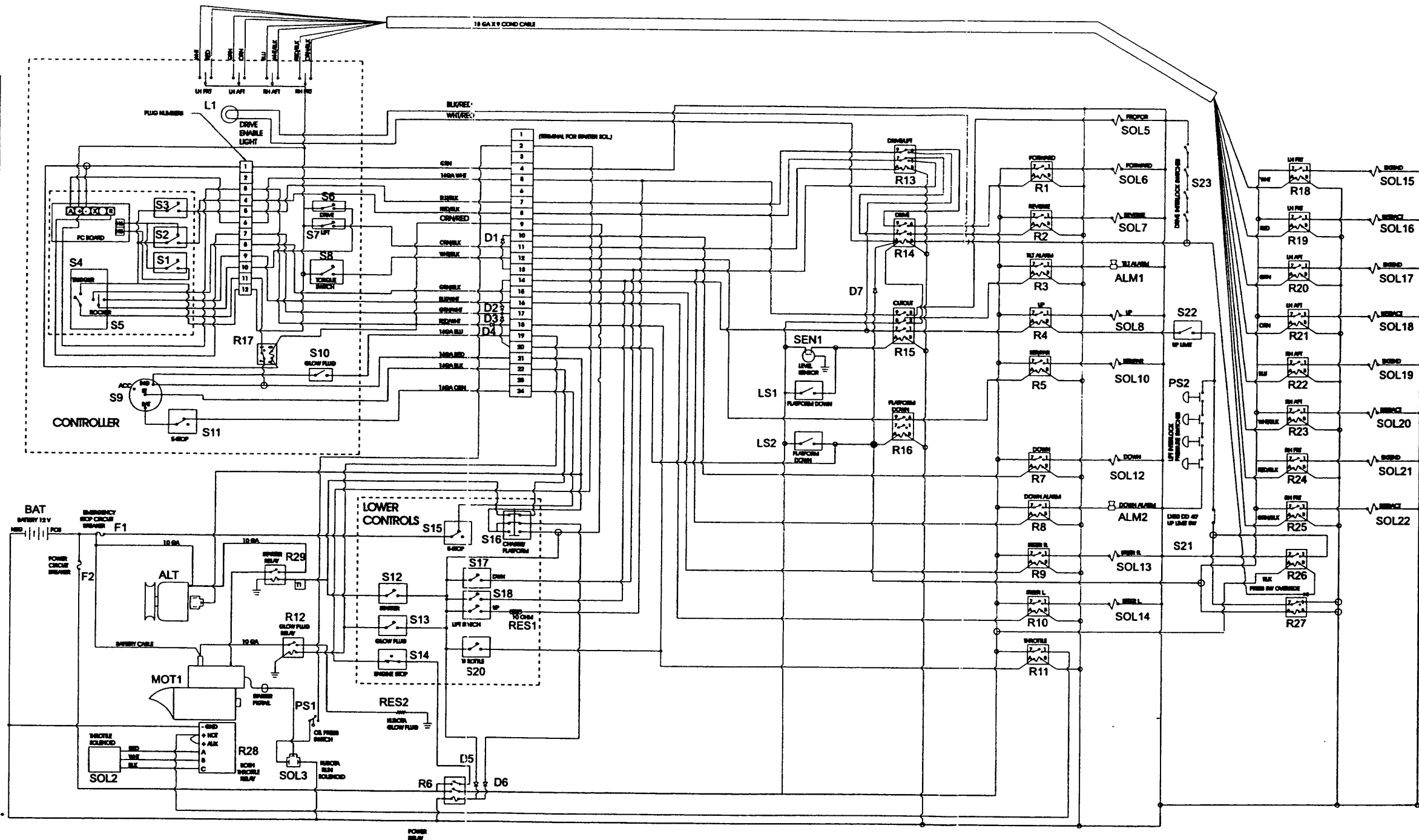

Figure 6-8: 067535-026 - 2WD Diesel Dual Deck with Outriggers

## 6.1 Electrical Schematics

Table 6-9: 067535-025 Four Wheel Drive Gasoline Dual Deck Model with Outriggers

REFERENCE DESIGNATION	NAME	FUNCTION	LOCATION
ALM 1	Tilt Alarm	Provides warning sound when slope of machine exceeds 3° side to side, or fore and aft.	Lower control box, exterior upper left side. Operated by the white wire.
ALM 2	Down Alarm	Provides warning sound when deck is lowering.	Lower control box, exterior upper left side. Operated by red wire.
ALT	Alternator	Maintains current during operation.	Power module, front left side of engine.
BAT	Battery	Provides power for starting engine.	Control module. On left in rear of module.
D1	Diode	Supplies power to down relay.	Between T10 and T11 on fanning strip.
D2	Diode	Supplies power to high speed enable circuit.	Between T16 and T17 on fanning strip.
D3	Diode	Supplies power to high speed enable circuit.	Between T17 and T18 on fanning strip.
D4	Diode	Supplies power to Throttle Solenoid.	Between T18 and T19 on fanning strip.
D5	Diode	Supplies power to power relay.	Lower control box by power relay.
D6	Diode	Supplies power to power relay.	Lower control box by power relay.
D7	Diode	Supplies power to drive relay.	Lower control box by drive relay.
D8	Diode	Power to Axle Float Relay.	Lower control box.
F1	Emergency Stop Circuit Breaker	Supplies Power to Upper Control Ignition Switch.	Lower control box mounted in panel, lower right hand.
F2	Power Circuit Breaker	Supplies power to all function solenoids.	Lower control box mounted in panel, lower left hand.
L1	Drive Enable Light	Indicates Drive Enabled.	Platform control box.
LS1	Down Limit Switch	Bypasses level sensor, supplying power to cutout relay when platform is lowered.	Under scissors, near front right hand side of chassis.
LS2	Down Limit Switch	Supplies power to drive and platform down relays, and high speed enable circuit on controller when platform is lowered.	Under scissors, near front right hand side of chassis.
MOT1	Starter Motor, and Solenoid	Provides power to starter motor from battery.	Left side of engine, in power module.
PS1	Oil Pressure Switch	Cuts power to engine when oil pressure falls to dangerous level.	Left side of engine, in power module.
PS2	Oil Pressure Switch	Lift/interlock Pressure Switches.	Outrigger Valve Block.
R1	Forward Relay	Switches power to forward solenoid.	Lower control box, second row, second relay from left.
R2	Reverse Relay	Switches power to reverse solenoid.	Lower control box, second row, third relay from left.
R3	Tilt Alarm Relay	Switches power to tilt alarm.	Lower control box, second row, fourth relay from left.
R4	Up Relay	Switches power to lift solenoid.	Lower control box, second row, fifth relay from left.
R5	Series / Parallel Relay	Switches power to series parallel solenoids.	Lower control box, second row, sixth relay from left.
R6	Power Relay	Switches power to all solenoids and engine.	Lower control box, first row, fourth relay from left.
R7	Down Relay	Switches power to down solenoid.	Lower control box, second row, seventh relay from left.

REFERENCE DESIGNATION	NAME	FUNCTION	LOCATION
R8	Down Alarm Relay	Switches power to down alarm.	Lower control box, second row, eighth relay from left.
R9	Steer Right Relay	Switches power to steer right solenoid.	Lower control box, second row, ninth relay from left.
R10	Steer Left Relay	Switches power to steer left solenoid.	Lower control box, second row, tenth relay from left.
R11	Throttle Relay	Switches power to throttle solenoid.	Lower control box, second row, eleventh relay from left.
R12	Glow Plug Relay	Power to Glow Plug.	Lower control box.
R13	Drive / Lift Relay	Directs power from forward (S1) and reverse (S2) switches to either forward / reverse or up / down relays.	Lower control box, first row, first relay from right.
R14	Drive Relay	Cuts power to forward and reverse relays when cutout relay is not energized and platform is elevated.	Lower control box, first row, second relay from left.
R15	Cutout Relay	Cuts power to drive and up relays when not energized by level sensor.	Lower control box, first row, third relay from left.
R16	Platform Down Relay	Cuts power to series / parallel relay when platform is elevated, selecting high torque mode.	Lower control box, second row, first relay from left.
R17	Ignition Relay	Power to Platform Ignition Switch.	Upper control box.
R18-R25	Outrigger Extend/Retract Relays	Power to Extend/Retract Relays.	Lower control box.
R26, 27	Pressure Switch Override Relays	Override Pressure Switches.	Lower control box.
R28	Throttle Relay	Controls Engine operation.	Engine Module.
R29	Starter Relay	Starts Engine.	Engine Module.
R30	Axle Float Relay	Allows Axle Float.	Lower control box.
RES1	Proportional Resistor	Limits current to proportional solenoid.	Lower control box.
RES2	Glow Plug	Heat to start engine.	Engine.
S1	Micro Switch	Supplies power to controller.	Upper control box, joystick.
S2	Reverse Micro Switch	Supplies power to drive / lift relay, forward / up contacts.	Upper control box, joystick.
S3	Forward Micro Switch	Supplies power to drive / lift relay, reverse / down contacts.	Upper control box, joystick.
S4	Interlock Micro Switch (Deadman Switch)	Interrupts power to controls when not engaged.	Upper control box, inside joystick handle.
S5	Steering Micro Switch (two)	Supplies power to steer left and steer right relays.	Upper control box, inside joystick handle.
S6,7	Drive / Lift Switch	Supplies Power to steering micro switch (drive) or to drive / lift relay (lift).	Upper control box, to the right of joystick.
S8	Torque Selector Switch	Supplies power to series / parallel relay.	Upper control box, to the right of joystick.
S9	Ignition Switch	Supplies power to upper controls, engine, and starter motor solenoid.	Upper control box, right side.
S10	Glow Plug Switch	Supplies power to glow plug relay.	Engine Module.
S11	Emergency Stop Switch	Cuts power to upper controls and engine.	Upper control box, to the left of joystick.
S12	Engine Start Switch	Starts Engine.	Engine Module.

Table 6-9: (cont.)

REFERENCE DESIGNATION	NAME	FUNCTION	LOCATION
S13	Glow Plug Switch	Heat Glow Plugs	Lower control box
S14	Engine Stop Switch	Selects LP or Gas	Engine Module
S15	Emergency Stop Switch	Cuts power to engine	Lower control box, in panel, top, first from left
S16	Chassis Platform Switch	Supplies power to either upper or lower controls	Lower control box, in panel, second from top, second from left.
S17	Down Switch	Supplies power to down relay.	Lower control box, in panel, third from top, first from left
S18-19	Raise Switch	Raise Platform	Lower control box
S20	Throttle Switch	Supplies power to throttle relay.	Lower control box, in panel, top, first from right
S21	40' Limit Switch	40 Drive Limit Switch	Chassis
S22	Up Limit Switch	Limits Lift Cylinder Extension	Chassis
S23	Drive Interlock Switches	Allow Drive Functions	Outriggers
SEN1	Level Sensor	Provides power to cutout relay when machine is level	Control module.
SOL2	Throttle Solenoid	Controls engine throttle.	Power module, engine, right side.
SOL3	Run Solenoid	Allows Engine Run with proper Oil Pressure	Engine
SOL5	Proportional Solenoid	Controls proportional valve.	Right side of manifold, port marked 'G'.
SOL6	Forward Solenoid	Controls forward valve.	Right side of valve manifold, port marked 'K'
SOL7	Reverse Solenoid	Controls reverse valve.	Right side of manifold, port marked 'L'
SOL8	Lift Solenoid.	Controls lift valve.	Right side of manifold, port marked 'J'.
SOL9	Shunt Solenoid		
SOL10	Series / Parallel Solenoid (two)	Controls series / parallel valves.	Front side of manifold, ports marked 'Q' & 'R'.
SOL11	Ade Float Solenoid	Allows Ade Float	Lower control box.
SOL12	Down Solenoid	Controls down valve	Lift cylinder, lower end.
SOL13	Steer Right Solenoid	Controls steer valve when steering right.	Top of manifold, on steer valve.
SOL14	Steer Left Solenoid	Controls steer valve when steering left.	Top of manifold, on steer valve
SOL15-22	Outrigger Extend/Retract Solenoids	Extend/Retract Solenoids	Outrigger Valve Block

Note: See Figure 6-20 for relay, terminal strip locations.

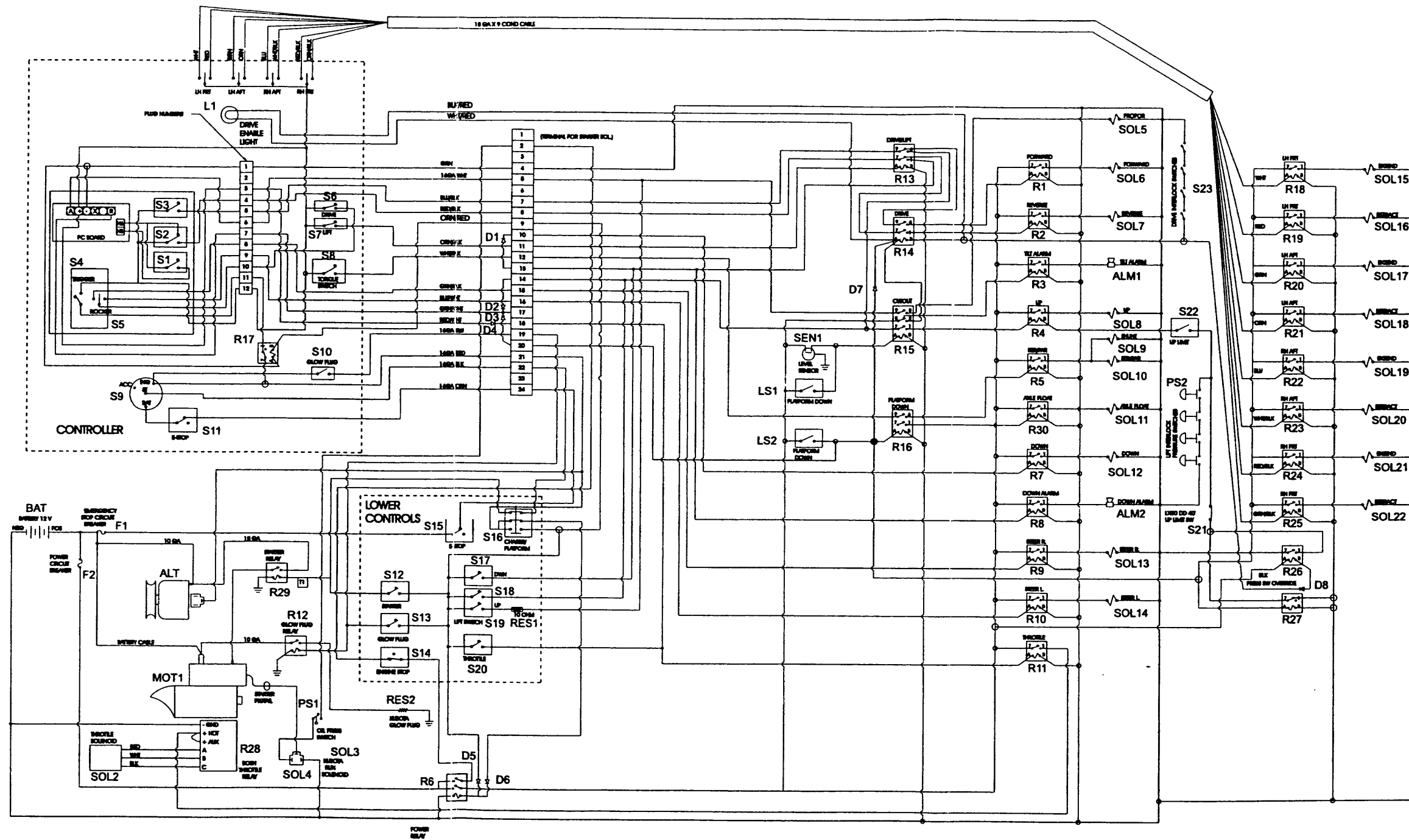

Figure 6-9: 067535-025 - 4WD Diesel Dual Deck with Outriggers - S/N 1331-2219

6.2 Hydraulic Schematics

Table 6-10: Two Wheel Drive Models

REFERENCE DESIGNATION	NAME	FUNCTION	LOCATION
CV1	Drive Make-up Check	Prevents cavitation of down stream motor when turning	Inline valve located bottom of manifold
CV2	Sense Line Check	Not Used	Not serviceable
CYL1	Steering Cylinder	Actuates steering linkage to steer front wheels.	Front axle assembly
CYL2,3	Lift Cylinder	Actuates scissor linkage to elevate platform	Scissor assembly
CYL4,5	Brakes, Multi-disc	Parking brakes, spring applied, hyd. release	Rear axle assembly
M 1,2	Rear Drive Motors	Drive the rear wheels.	Rear axle assembly
ORF1	Steering Orifice	Limits the oil flow to the steering cylinder	Under stack valve SV2 between steer valve (V1) and manifold
ORF2, 3	Down Orifice	Limits the descent speed of the platform	Under down valves
ORF4	Brake Orifice	Allows brakes to release quickly and apply slowly	Left side top of manifold under fitting in port 12
P1	Hydraulic Pump	Provides fluid power for hydraulic system	Power module, engine assembly
P2	Brake Release Pump	Used to release brakes when machine is towed.	Near rear axle assembly outside housing.
RV1	Right Steer Relief Valve	Provides overpressure protection for steering components.	Front of manifold
RV2	Left Steer Relief Valve	Provides overpressure protection for steering components.	Front of manifold
RV3	Lift Relief Valve	Limits maximum load of elevating assembly.	Front of manifold
RV4,5	Bi-Directional Relief Valves	Allows oil flow to bypass drive motors when turning on tight radius.	Underneath each rear drive motor
SV1	Sense Line Shuttle Valve	Not used	Not serviceable
SV2	Sense Line Shuttle Valve	Allows pilot pressure to pump sense line from steering	Stack valve located between steering valve (V1) and manifold.
SV3	Drive Shuttle Valve	Allows oil pressure from drive to release brakes.	Not serviceable.

REFERENCE DESIGNATION	NAME	FUNCTION	LOCATION
V1	Steering Valve	Controls oil flow to steering cylinder (CYL1)	Top of manifold, ports marked 'D'
V2	Emergency Down Valve	Emergency lowering	Rear of elevating assembly
V3	Proportional Valve	Regulates oil flow to lift and drive functions	Right side of manifold, port marked 'G'
V4	Lift Valve	Allows oil flow to lift cylinders	Right side of manifold, port marked 'J'
V5	Forward Valve	Allows oil flow to drive system in forward, allows return of flow from drive system in reverse	Right side of manifold port marked 'K'
V6	Reverse Valve	Allows oil flow to drive system in reverse, allows return of flow from drive system in forward	Right side of manifold port marked 'L'
V7	Forward Counter-balance Valve	Provides dynamic braking for machine in reverse and prevents runaway on slopes	Left side of manifold, port marked 'N'
V8	Reverse Counter-balance Valve	Provides dynamic braking for machine in forward and prevents runaway on slopes	Left side of manifold, port marked 'O'
V9,10	Series / Parallel Valves	Directs oil flow to drive motors in either series (for higher speed) or parallel (for higher torque) configuration	Front of manifold, ports marked 'R' & 'Q'
V11	Divider / Combiner Valve	Equalizes oil flow from front and rear drive motors when in parallel (High Torque) configuration	Front of manifold, port marked 'P'
V12,13	Down Valves	Lower Cylinders	Base of cylinders
V14,15	Velocity Fuse Valve	Lock cylinder if hose breaks	Inside cylinders

Note: See figure 6-15 for hydraulic valve locations.

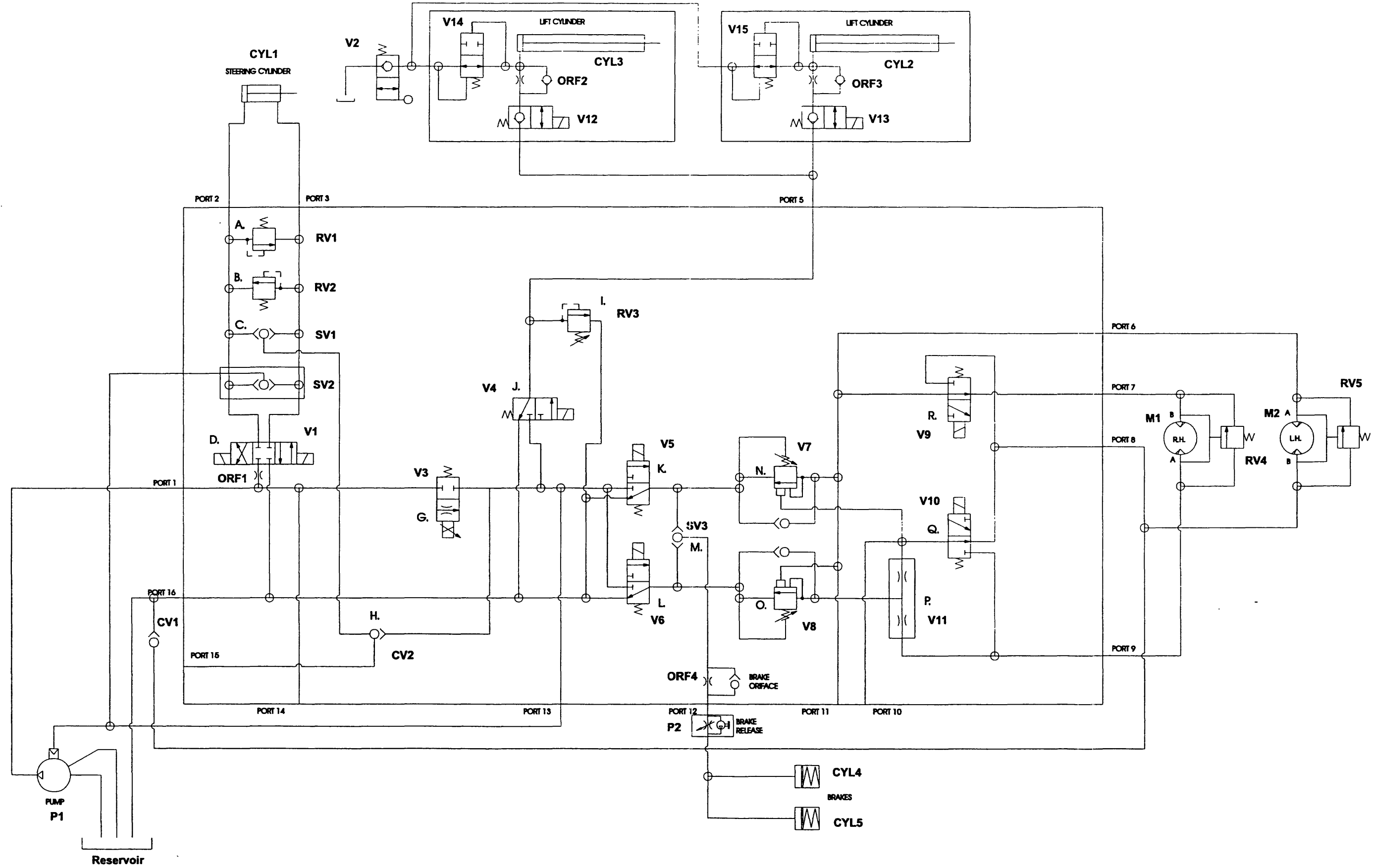

Figure 6-10: 067534-002 Two Wheel Drive Models

6.2 Hydraulic Schematics

Table 6-11: Four Wheel Drive Models

REFERENCE DESIGNATION	NAME	FUNCTION	LOCATION
CV1	Drive Make-up Check	Prevents cavitation of down stream motor when turning	In-line valve located bottom of manifold
CV2	Sense Line Check	Not Used	Not serviceable
CYL1	Steering Cylinder	Actuates steering linkage to steer front wheels	Front axle assembly
CYL2,3	Lift Cylinder	Actuates scissor linkage to elevate platform	Scissor assembly
CYL4,5	Brakes, Multi-disc	Parking brakes, spring applied, hyd release	Rear axle assembly
CYL6	Axle Float Cylinder	Axle Float	Front Axle
M 1,2	Front Drive Motors	Drive the front wheels.	Front axle assembly
M 3,4	Rear Drive Motors	Drive the rear wheels	Rear axle assembly
ORF1	Steering Orifice	Limits the oil flow to the steering cylinder	Under stack valve SV2 between steer valve (V1) and manifold
ORF2, 3	Down Orifice	Limits the descent speed of the platform.	Under down valves
ORF4	Brake Orifice	Allows brakes to release quickly and apply slowly.	Left side top of manifold under fitting in port 12.
P1	Hydraulic Pump	Provides fluid power for hydraulic system.	Power module, engine assembly
P2	Brake Release Pump	Used to release brakes when machine is towed	Near rear axle assembly outside housing
RV1	Right Steer Relief Valve	Provides overpressure protection for steering components.	Front of manifold
RV2	Left Steer Relief Valve	Provides overpressure protection for steering components.	Front of manifold
RV3	Lift Relief Valve	Limits maximum load of elevating assembly.	Front of manifold
RV4,5	Bi-Directional Relief Valves	Allows oil flow to bypass drive motors when turning on tight radius	Underneath each rear drive motor
SV1	Sense Line Shuttle Valve	Not used	Not serviceable
SV2	Sense Line Shuttle Valve	Allows pilot pressure to pump sense line from steering	Stack valve located between steering valve (V1) and manifold
SV3	Drive Shuttle Valve	Allows oil pressure from drive to release brakes	Not serviceable

REFERENCE DESIGNATION	NAME	FUNCTION	LOCATION
V1	Steering Valve	Controls oil flow to steering cylinder (CYL1)	Top of manifold, ports marked 'D'
V2	Emergency Down Valve	Emergency lowering	Rear of elevating assembly
V3	Proportional Valve	Regulates oil flow to lift and drive functions.	Right side of manifold, port marked 'G.'
V4	Lift Valve	Allows oil flow to lift cylinders	Right side of manifold, port marked 'J'
V5	Forward Valve	Allows oil flow to drive system in forward, allows return oil flow from drive system in reverse.	Right side of manifold port marked 'K.'
V6	Reverse Valve	Allows oil flow to drive system in reverse, allows return oil flow from drive system in forward.	Right side of manifold port marked 'L'
V7	Forward Counter-balance Valve	Provides dynamic braking for machine in reverse and prevents runaway on slopes.	Left side of manifold, port marked 'N'
V8	Reverse Counter-balance Valve	Provides dynamic braking for machine in forward and prevents runaway on slopes.	Left side of manifold, port marked 'O'.
V9,10	Series / Parallel Valves	Directs oil flow to drive motors in either series (for higher speed) or parallel (for higher torque) configuration.	Front of manifold, ports marked 'R' & 'Q'.
V11	Divider / Combiner Valve	Equalizes oil flow from front and rear drive motors when in parallel (High Torque) configuration.	Front of manifold, port marked 'P'.
V12,13	Down Valve	Lower Cylinders	Base of cylinders
V14,15	Velocity Fuse Valve	Lock cylinder if hose breaks	Inside cylinders

Note: See Figure 6-16 for hydraulic valve locations.

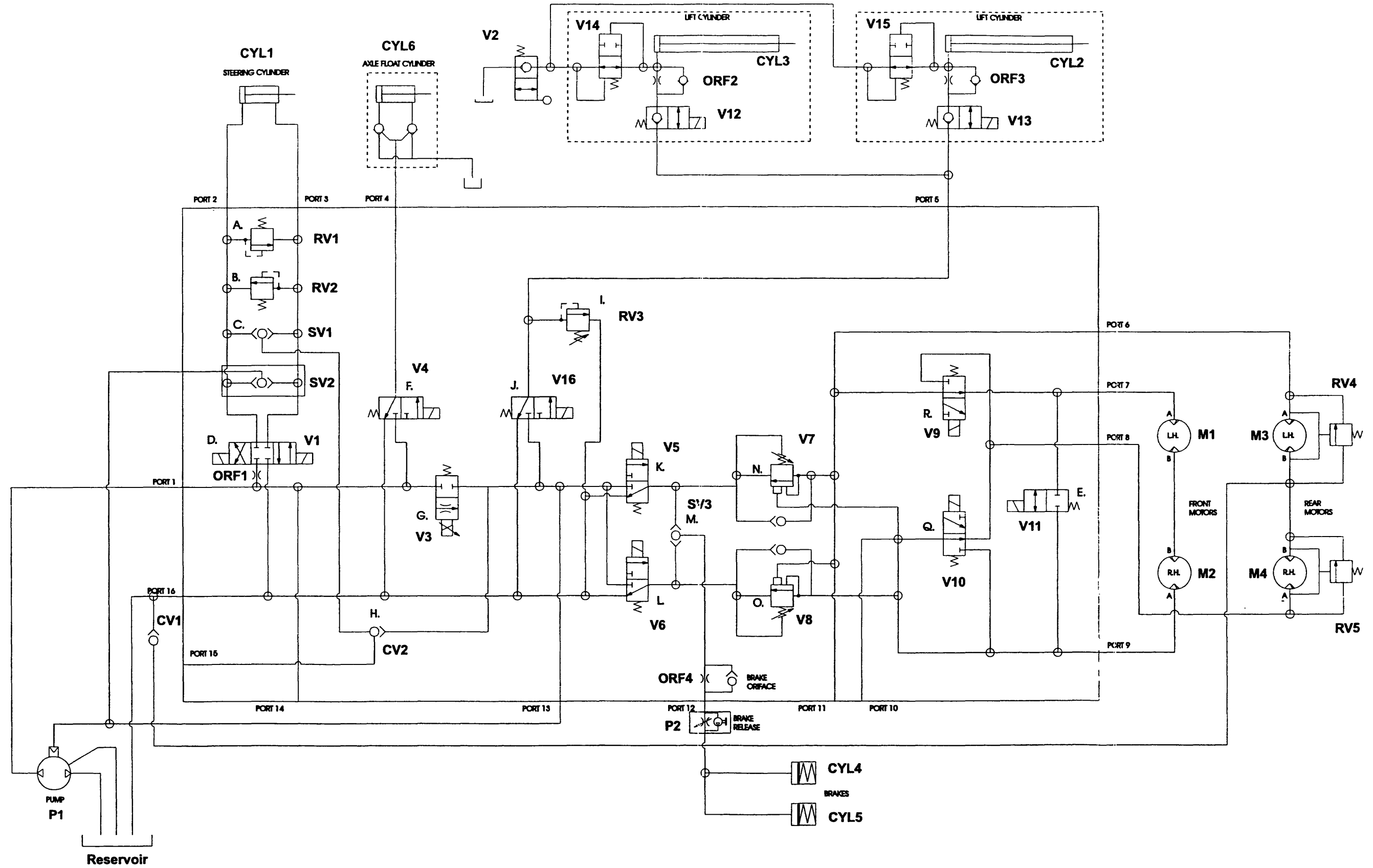

Figure 6-11: 067534-003 Four Wheel Drive Models

6.2 Hydraulic Schematics

Table 6-12: Two Wheel Drive Models with Outriggers

REFERENCE DESIGNATION	NAME	FUNCTION	LOCATION
CV1	Drive Make-up Check	Prevents cavitation of down stream motor when turning	Inline valve located bottom of manifold
CV2	Sense Line Check	Not Used	Not serviceable
CV3 4,5,6	Check valve	Send pressure signal to Pump	Outrigger Valve Block
CYL1	Steering Cylinder	Actuates steering linkage to steer front wheels.	Front axle assembly
CYL2,3	Lift Cylinder	Actuates scissor linkage to elevate platform	Scissor assembly
CYL4,5	Brakes, Multi-disc	Parking brakes, spring applied, hyd release.	Rear axle assembly
CYL6,7,8,9	Outrigger Cylinders	Level machine	Corners of chassis
M 1,2	Drive Motors	Drive the rear wheels.	Rear axle assembly
ORF1	Steering Orifice	Limits the oil flow to the steering cylinder	Under stack valve SV2 between steer valve (V1) and manifold.
ORF2, 3	Down Orifice	Limits the descent speed of the platform.	Under down valves
ORF4	Brake Orifice	Allows brakes to release quickly and apply slowly.	Left side top of manifold under fitting in port 12
P1	Hydraulic Pump	Provides fluid power for hydraulic system	Power module, engine assembly.
P2	Brake Release Pump	Used to release brakes when machine is towed.	Near rear axle assembly outside housing.
RV1	Right Steer Relief Valve	Provides overpressure protection for steering components.	Front of manifold
RV2	Left Steer Relief Valve	Provides overpressure protection for steering components	Front of manifold
RV3	Lift Relief Valve	Limits maximum load of elevating assembly.	Front of manifold
RV4,5	Bi-Directional Relief Valves	Allows oil flow to bypass drive motors when turning on tight radius.	Underneath each rear drive motor.
RV6,7,8,9,10,11,12,13	Relief Valve	Lock Outrigger Cylinders	Outrigger Cylinders
SV1	Sense Line Shuttle Valve	Not used	Not serviceable
SV2	Sense Line Shuttle Valve	Allows pilot pressure to pump sense line from steering	Stack valve located between steering valve (V1) and manifold.
SV3	Drive Shuttle Valve	Allows oil pressure from drive to release brakes	Not serviceable.

REFERENCE DESIGNATION	NAME	FUNCTION	LOCATION
V1	Steering Valve	Controls oil flow to steering cylinder (CYL1)	Top of manifold, ports marked 'D'
V2	Emergency Down Valve	Emergency lowering	Rear of elevating assembly
V3	Proportional Valve	Regulates oil flow to lift and drive functions	Right side of manifold, port marked 'C'
V4	Lift Valve	Allows oil flow to lift cylinders	Right side of manifold, port marked 'J'
V5	Forward Valve	Allows oil flow to drive system in forward, allows return oil flow from drive system in reverse	Right side of manifold port marked 'K'
V6	Reverse Valve	Allows oil flow to drive system in reverse, allows return oil flow from drive system in forward	Right side of manifold port marked 'L'
V7	Forward Counter-balance Valve	Provides dynamic braking for machine in reverse and prevents runaway on slopes	Left side of manifold, port marked 'N'
V8	Reverse Counter-balance Valve	Provides dynamic braking for machine in forward and prevents runaway on slopes.	Left side of manifold, port marked 'O'
V9,10	Series / Parallel Valves	Directs oil flow to drive motors in either series (for higher speed) or parallel (for higher torque) configuration	Front of manifold, ports marked 'R' & 'Q'
V11	Divider / Combiner Valve	Equalizes oil flow from front and rear drive motors when in parallel (High Torque) configuration.	Front of manifold, port marked 'P'
V12,13	Down Valve	Lower Cylinders	Base of cylinders
V14,15	Velocity Fuse Valve	Lock cylinder if hose breaks	Inside cylinders
V16,17,18,19	Outrigger valves	Operate outrigger Cylinders	Outrigger valve block

Note: See figure 6-15 for hydraulic valve locations.



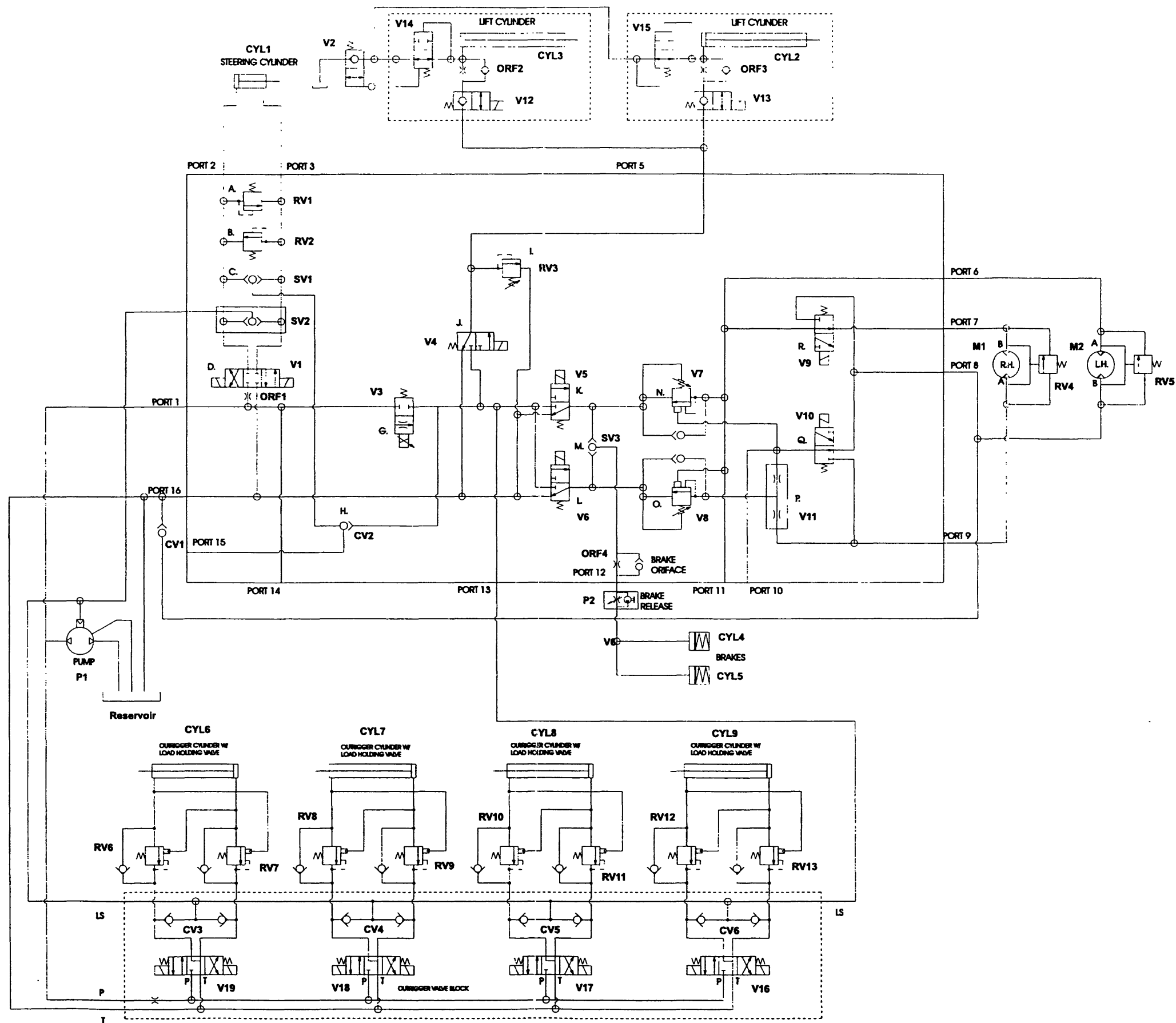

6.2 Hydraulic Schematics

Table 6-13: Four Wheel Drive Models with Outriggers

REFERENCE DESIGNATION	NAME	FUNCTION	LOCATION
CV1	Drive Make-up Check	Prevents cavitation of down stream motor when turning	Inline valve located bottom of manifold
CV2	Sense Line Check	Not Used	Not serviceable
CV3,4,5,6	Check valve	Send pressure signal to Pump	Outrigger Valve Block
CYL1	Steering Cylinder	Actuates steering linkage to steer front wheels.	Front axle assembly
CYL2,3	Lift Cylinder	Actuates scissor linkage to elevate platform	Scissor assembly
CYL4,5	Brakes, Multi-disc	Parking brakes, spring applied, hyd. release.	Rear axle assembly
CYL6,7,8,9	Outrigger Cylinders	Level machine	Corners of chassis
CYL10	Axle Float Cylinder	Controls Axle Float	Front Axle
M 1, 2	Front Drive Motors	Drive the front wheels	Front axle assembly
M 3, 4	Rear Drive Motors	Drive the rear wheels	Rear axle assembly
ORF1	Steering Orifice	Limits the oil flow to the steering cylinder.	Under stack valve SV2 between steer valve (V1) and manifold
ORF2, 3	Down Orifice	Limits the descent speed of the platform.	Under down valves
ORF4	Brake Orifice	Allows brakes to release quickly and apply slowly.	Left side top of manifold under fitting in port 12.
P1	Hydraulic Pump	Provides fluid power for hydraulic system.	Power module, engine assembly.
P2	Brake Release Pump	Used to release brakes when machine is towed	Near rear axle assembly outside housing
RV1	Right Steer Relief Valve	Provides overpressure protection for steering components.	Front of manifold
RV2	Left Steer Relief Valve	Provides overpressure protection for steering components.	Front of manifold
RV3	Lift Relief Valve	Limits maximum load of elevating assembly.	Front of manifold
RV4,5	Bi-Directional Relief Valves	Allows oil flow to bypass drive motors when turning on tight radius.	Underneath each rear drive motor
RV6,7,8,9,10,11,12,13	Relief Valve	Lock Outrigger Cylinders	Outrigger Cylinders
SV1	Sense Line Shuttle Valve	Not used	Not serviceable.
SV2	Sense Line Shuttle Valve	Allows pilot pressure to pump sense line from steering.	Stack valve located between steering valve (V1) and manifold.
SV3	Drive Shuttle Valve	Allows oil pressure from drive to release brakes.	Not serviceable.

REFERENCE DESIGNATION	NAME	FUNCTION	LOCATION
V1	Steering Valve	Controls oil flow to steering cylinder (CYL1)	Top of manifold, ports marked 'D'
V2	Emergency Down Valve	Emergency lowering	Rear of elevating assembly
V3	Proportional Valve	Regulates oil flow to lift and drive functions	Right side of manifold, port marked 'G'
V4	Lift Valve	Allows oil flow to lift cylinders	Right side of manifold, port marked 'J'.
V5	Forward Valve	Allows oil flow to drive system in forward. allows return oil flow from drive system in reverse	Right side of manifold port marked 'K'
V6	Reverse Valve	Allows oil flow to drive system in reverse. allows return oil flow from drive system in forward	Right side of manifold port marked 'L'.
V7	Forward Counter-balance Valve	Provides dynamic braking for machine in reverse and prevents runaway on slopes.	Left side of manifold, port marked 'N'.
V8	Reverse Counter-balance Valve	Provides dynamic braking for machine in forward and prevents runaway on slopes.	Left side of manifold, port marked 'O'
V9,10	Series / Parallel Valves	Directs oil flow to drive motors in either series (for higher speed) or parallel (for higher torque) configuration.	Front of manifold, ports marked 'R' & 'Q'.
V11	Divider / Combiner Valve	Equalizes oil flow from front and rear drive motors when in parallel (High Torque) configuration	Front of manifold, port marked 'P'
V12,13	Down Valve	Lower Cylinders	Base of cylinders
V14,15	Velocity Fuse Valve	Lock cylinder if hose breaks	Inside cylinders
V16,17,18,19	Outrigger valves	Operate outrigger Cylinders	Outrigger valve block
V20	Axle Float Valve	Control Axle Float Cylinder	Valve Manifold

Note: See figure 6-16 for hydraulic valve locations.

# Schematics

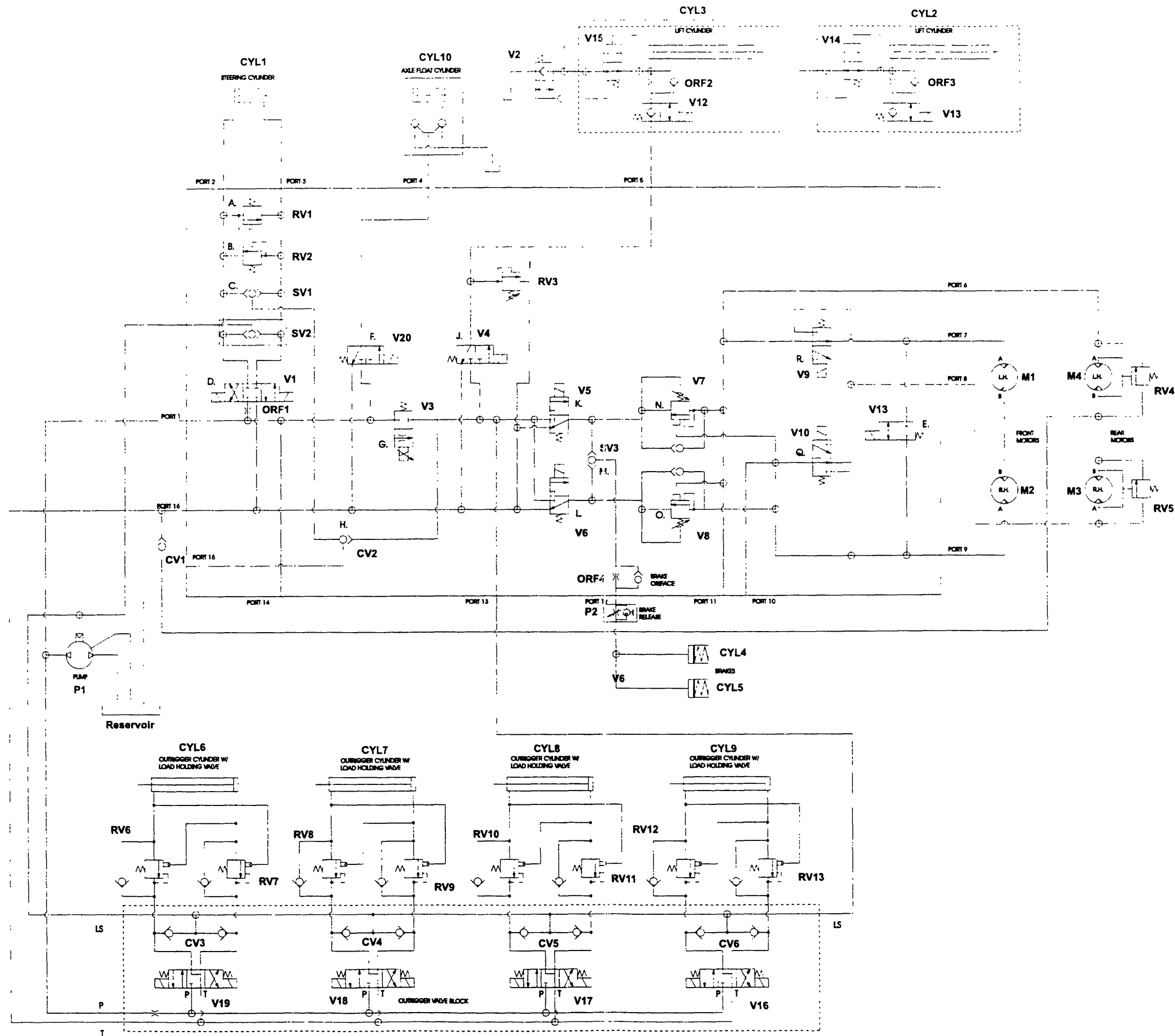

Figure 6-13: 067534-013 Four Wheel Drive Models with Outriggers

6.3 Component Location

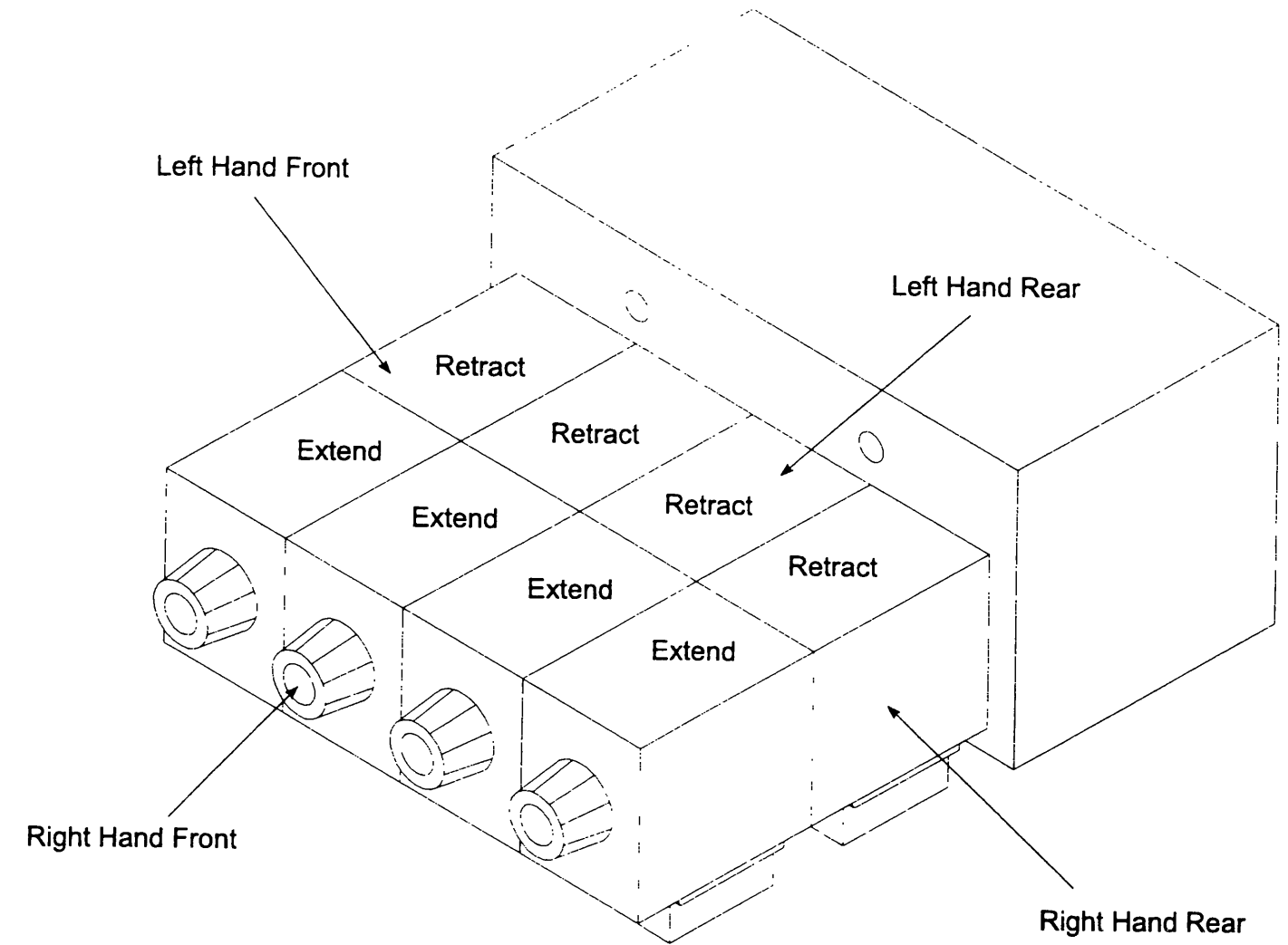

Figure 6-14: Outrigger Valve Components

## 6.4 Lower Control Box Component Location

### Lower Controller Components

1. Emergency Stop Button
2. Platform/Chassis Switch
3. Stop Button
4. Start Button
5. Throttle Button
6. Choke/Glow Plug Button
7. Raise Button
8. Down Alarm
9. Up Alarm
10. Lower Button
11. Fuel Selector Switch
12. Cable Connector, 3/4"
13. Circuit Breaker, 15 Amp

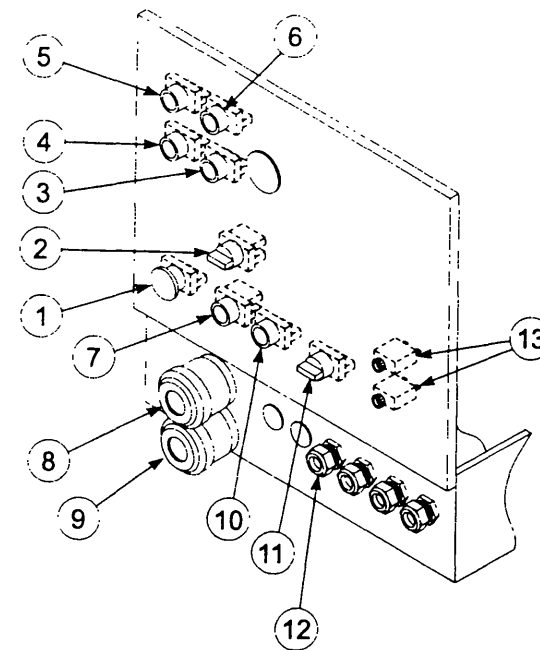

Figure 6-19: Lower Control Box Cover

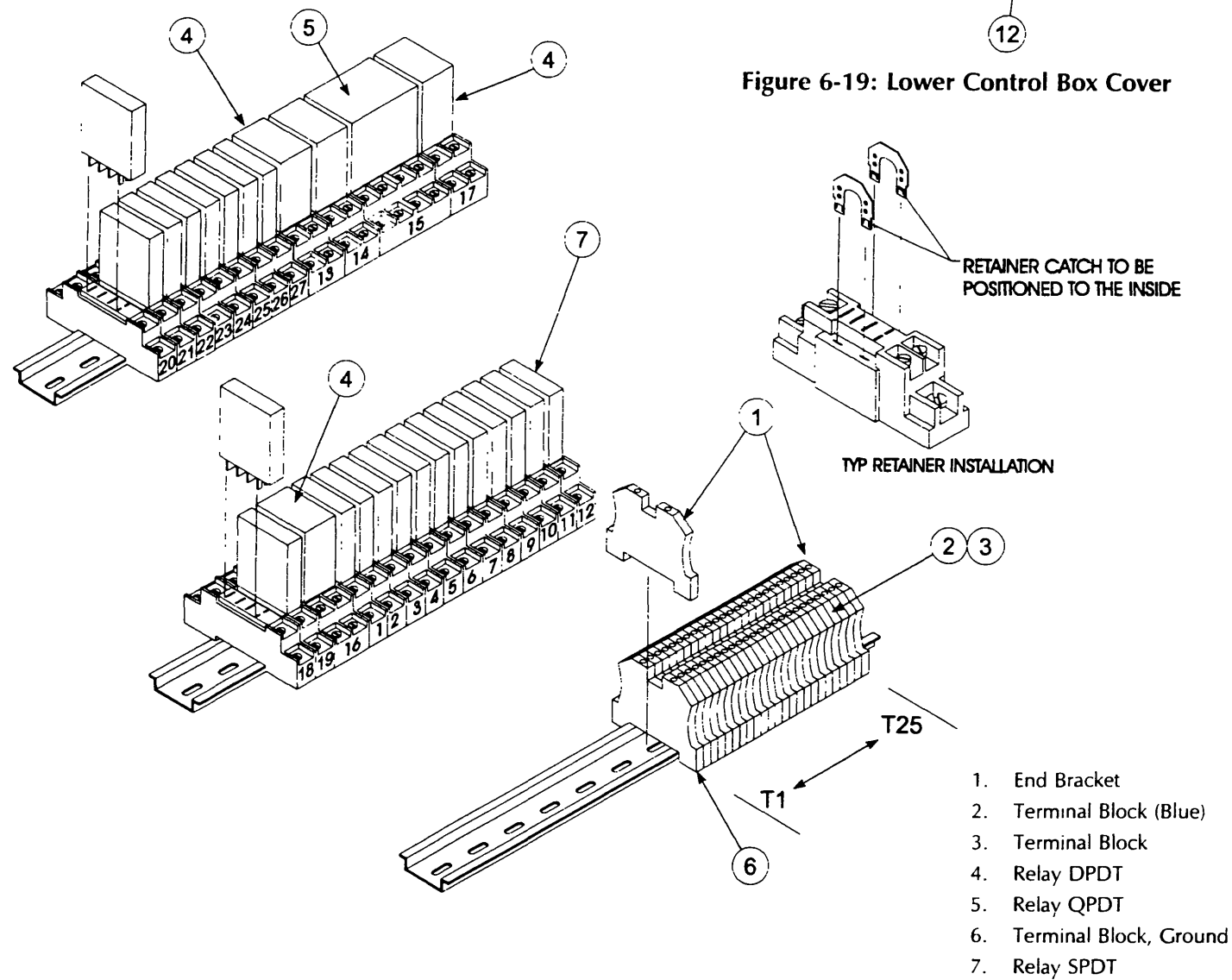

Figure 6-20: Terminal Strip, Relay Identification - Outrigger Model Shown

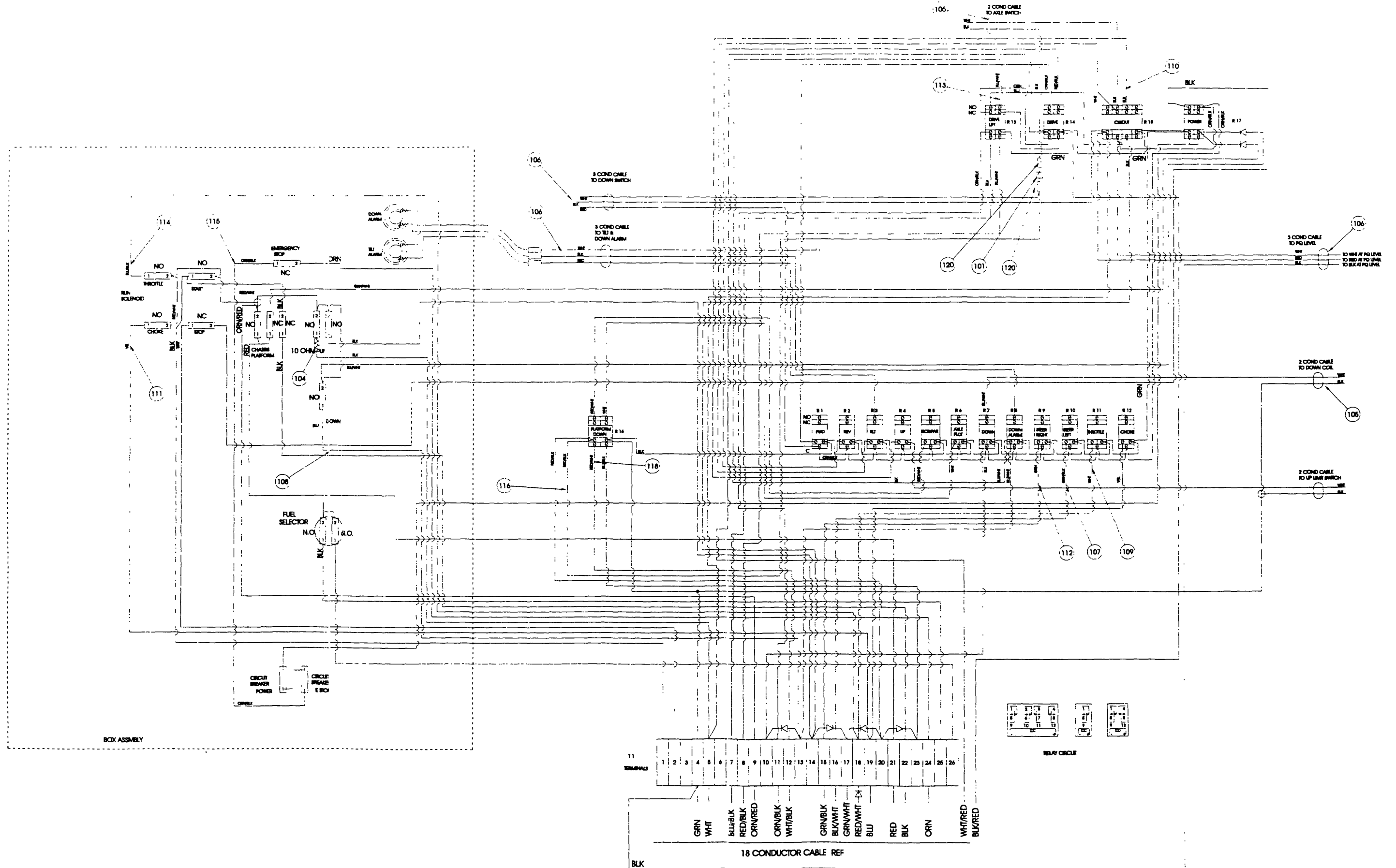

Figure 6-21: 067527-000#2 - Lower Control Box - Gasoline Model

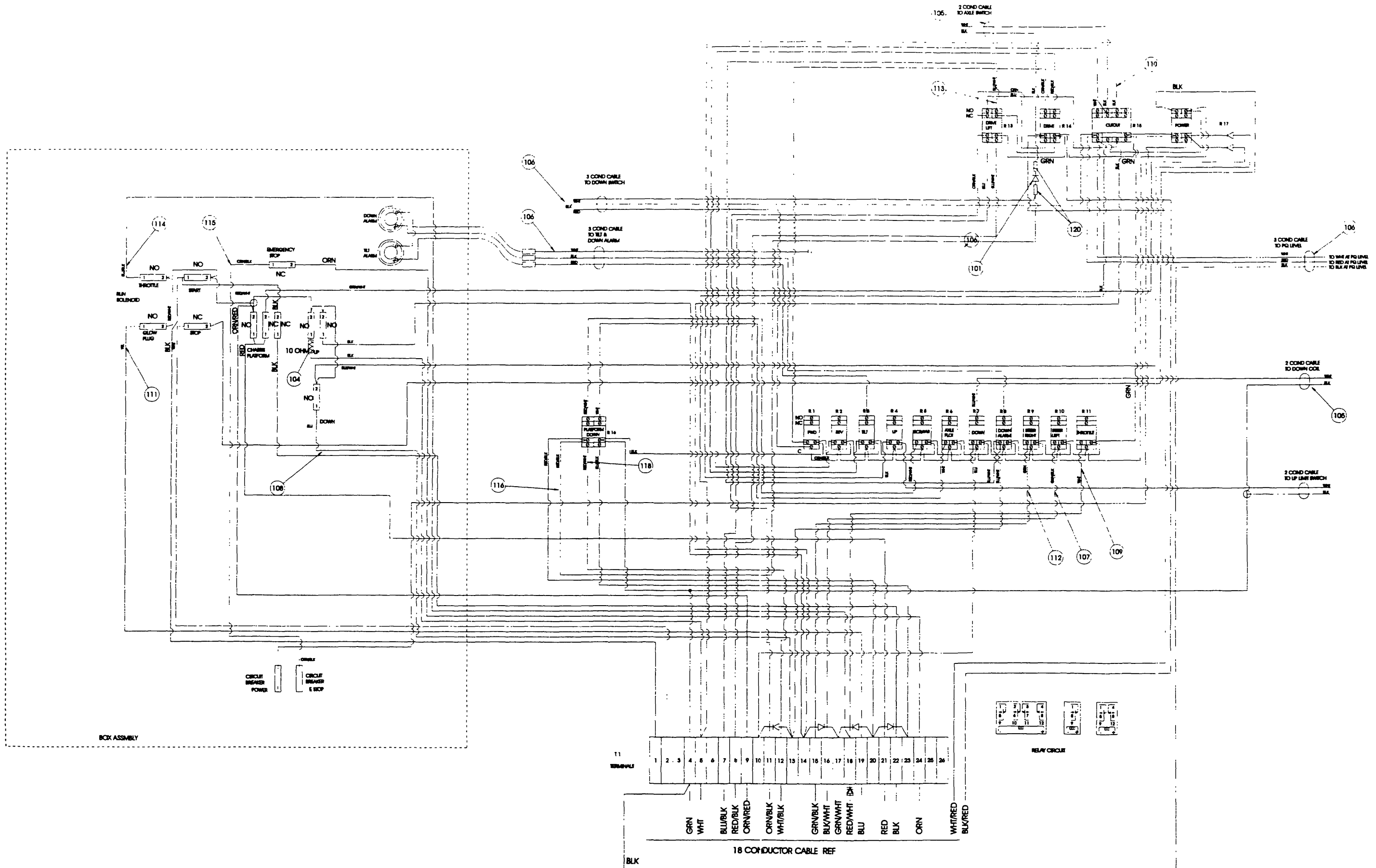

Figure 6-22: 067527-001#2 - Lower Control Box - Diesel Model

6.5 Upper Control Box Component Location

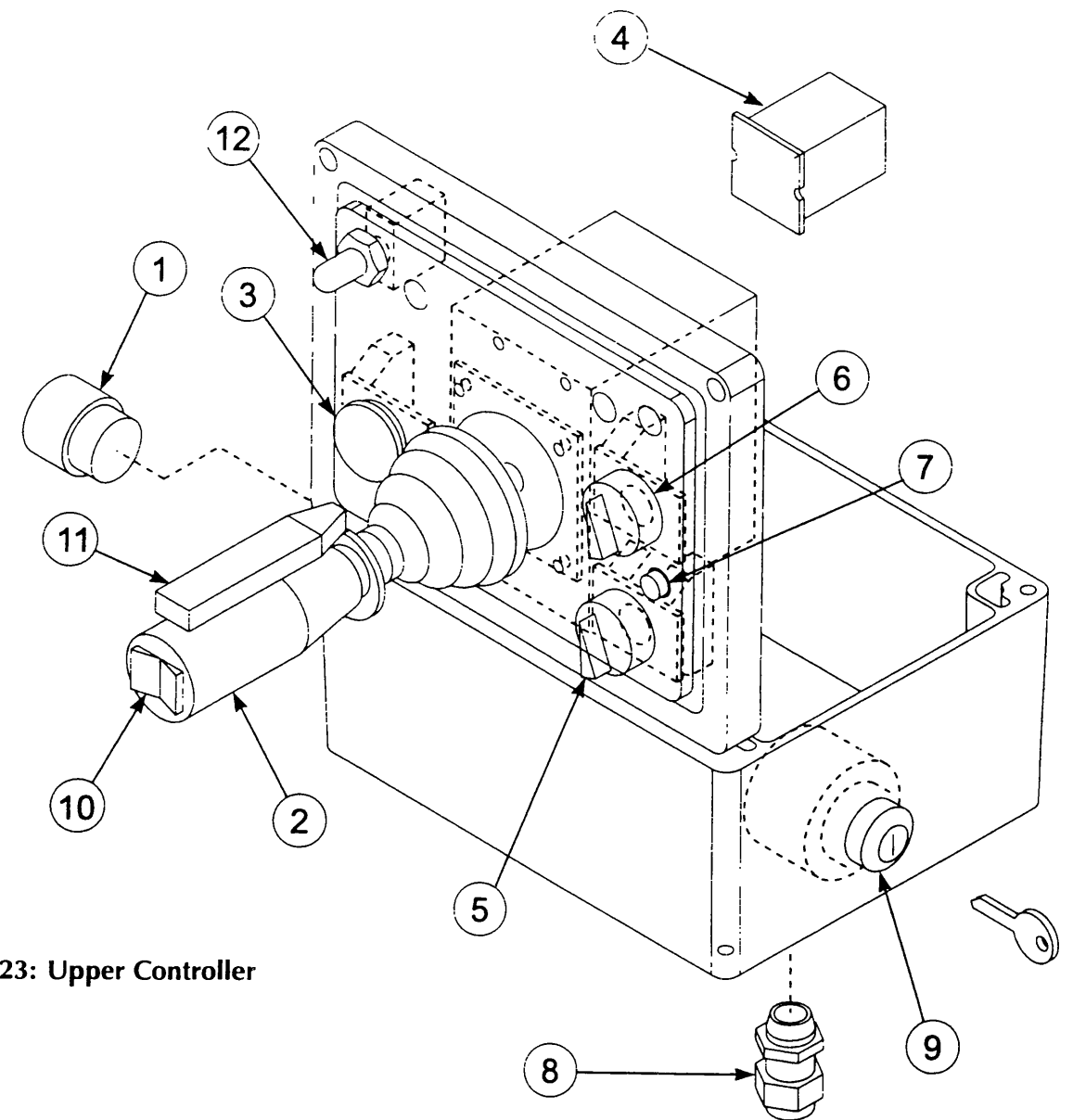

Figure 6-23: Upper Controller

Upper Controller Components

1. Choke/Glow Plug Button
2. Control Lever
3. Emergency Stop Button
4. Relay
5. Lift/Drive Switch
6. Speed Range Switch
7. Drive Enable Indicator
8. Cable Connector, 3/4"
9. Key Switch
10. Steering Switch
11. Interlock Lever
12. Outrigger Switches (optional)



# Schematics

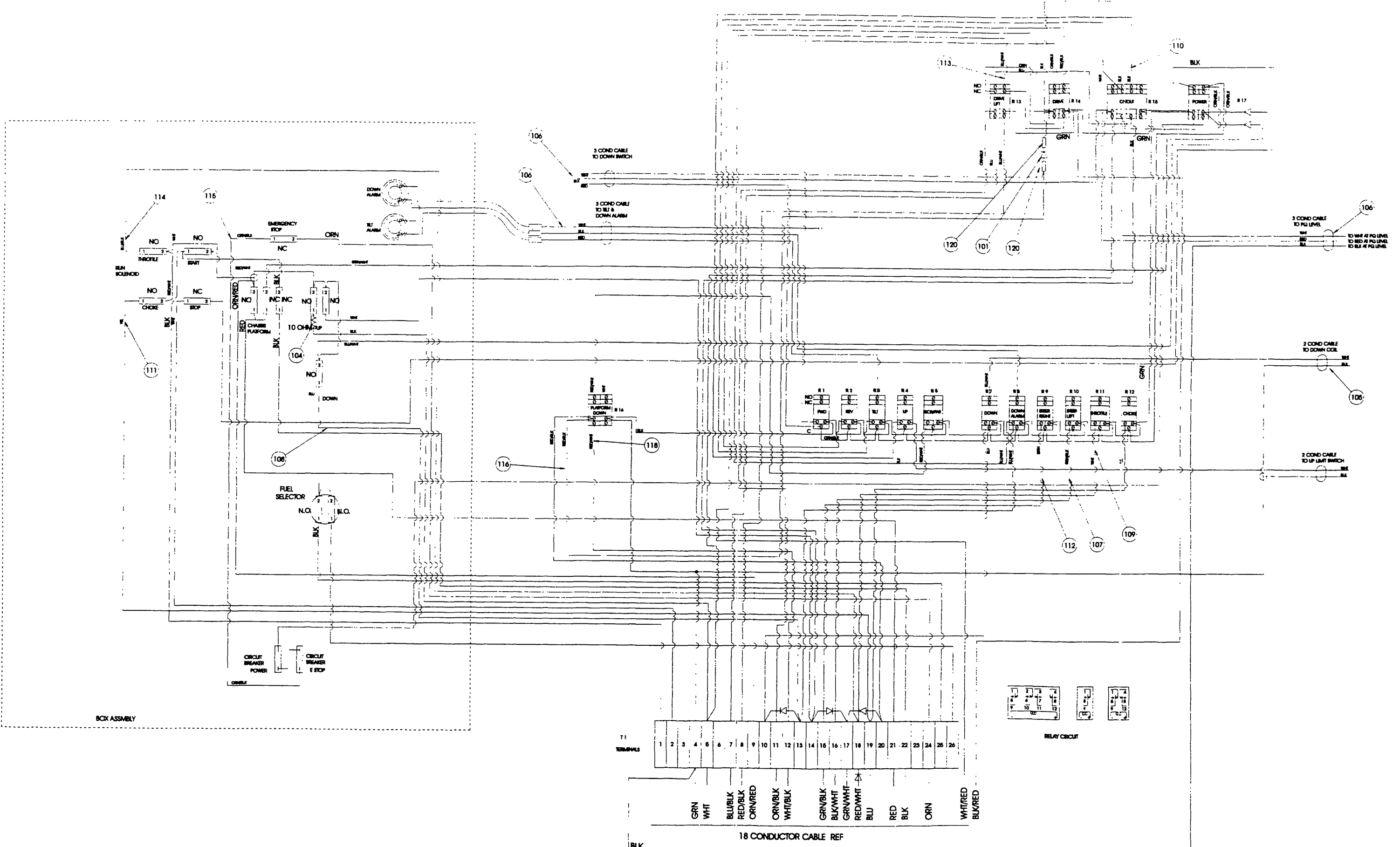

Figure 6-24: 067527-002#2 - Platform Control Box - Gasoline Model

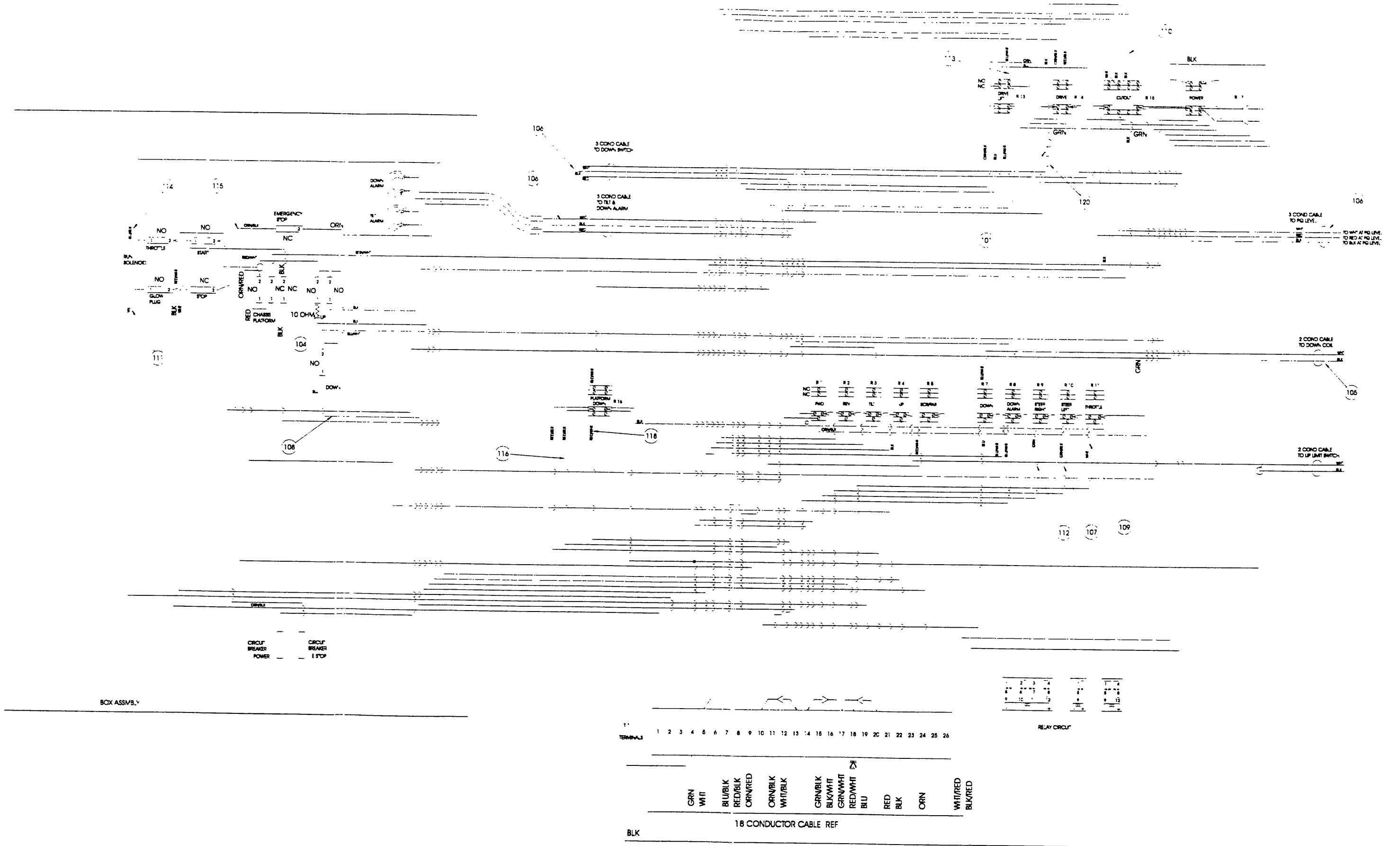
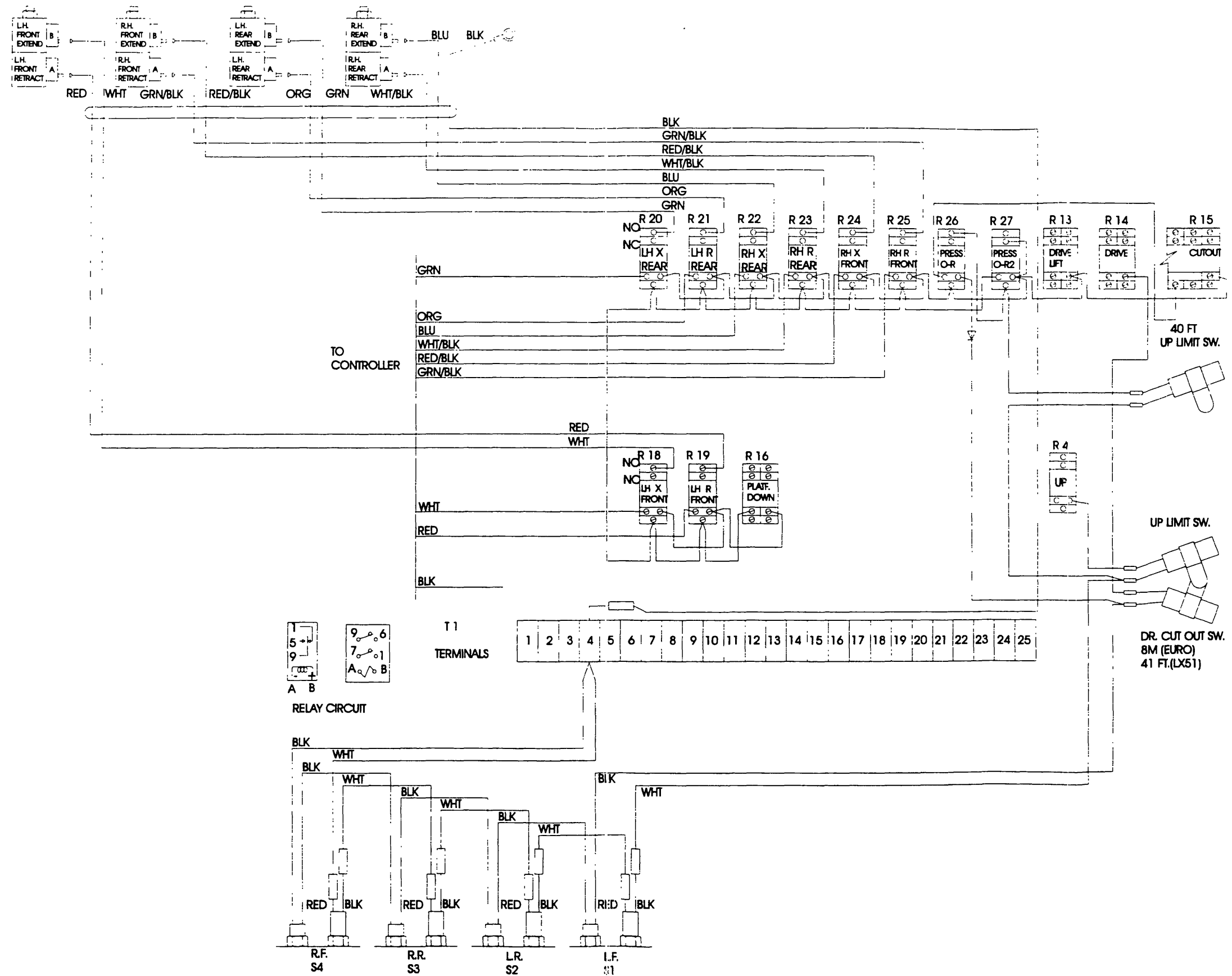

Figure 6-25: 067527-003#2 - Platform Control Box - Diesel Model



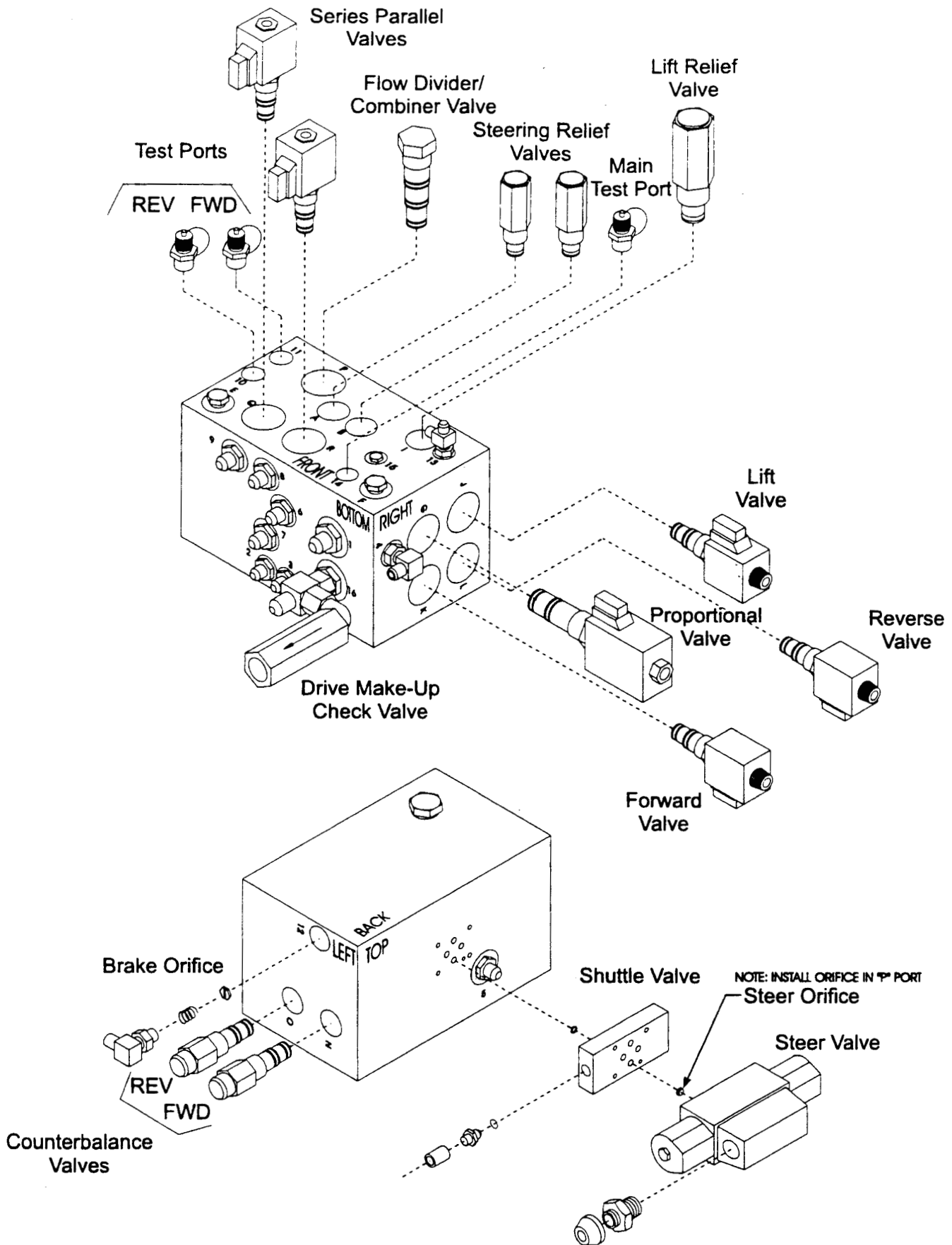

Figure 6-15: 2WD Hydraulic Manifold

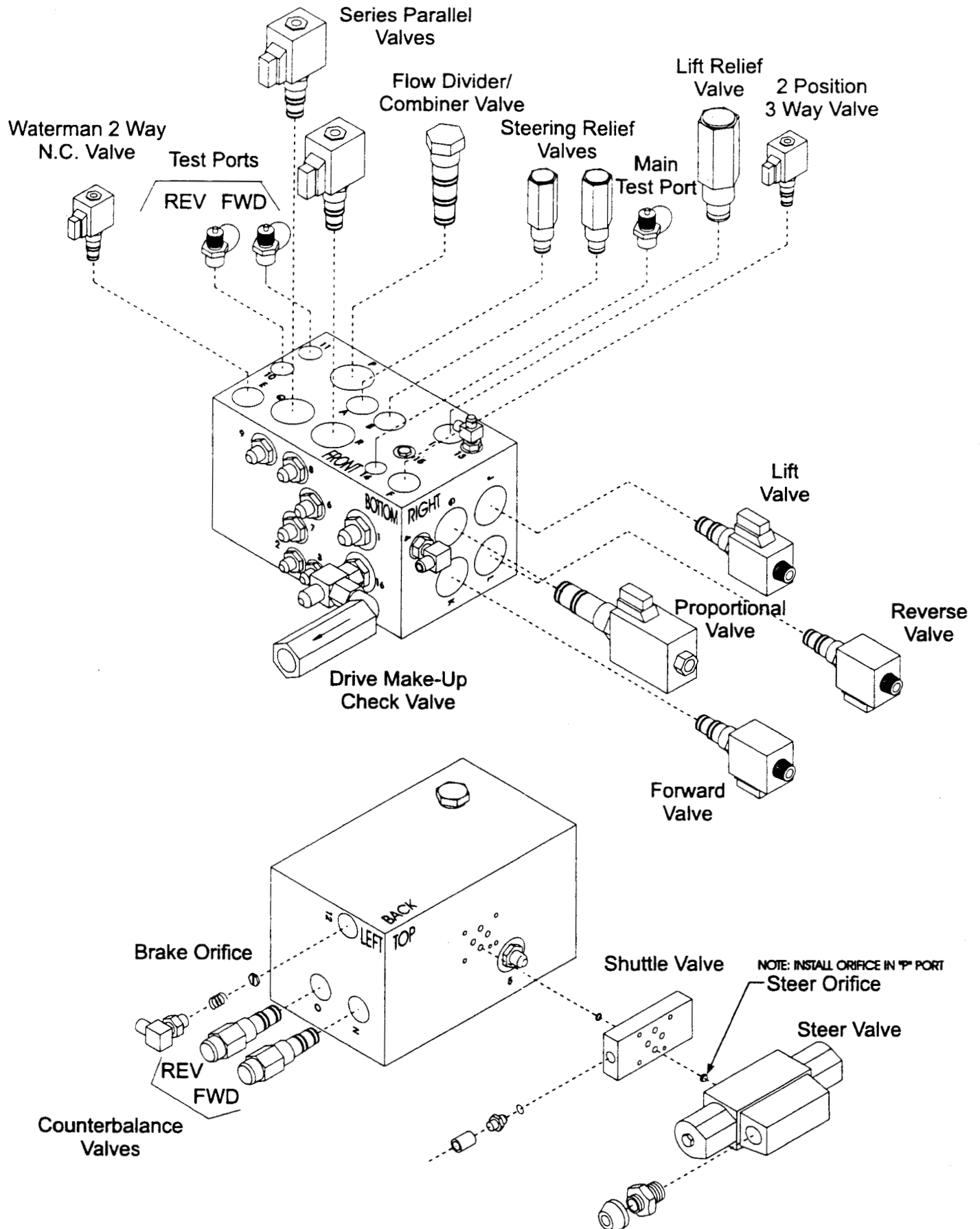

Figure 6-16: 4WD Hydraulic Manifold

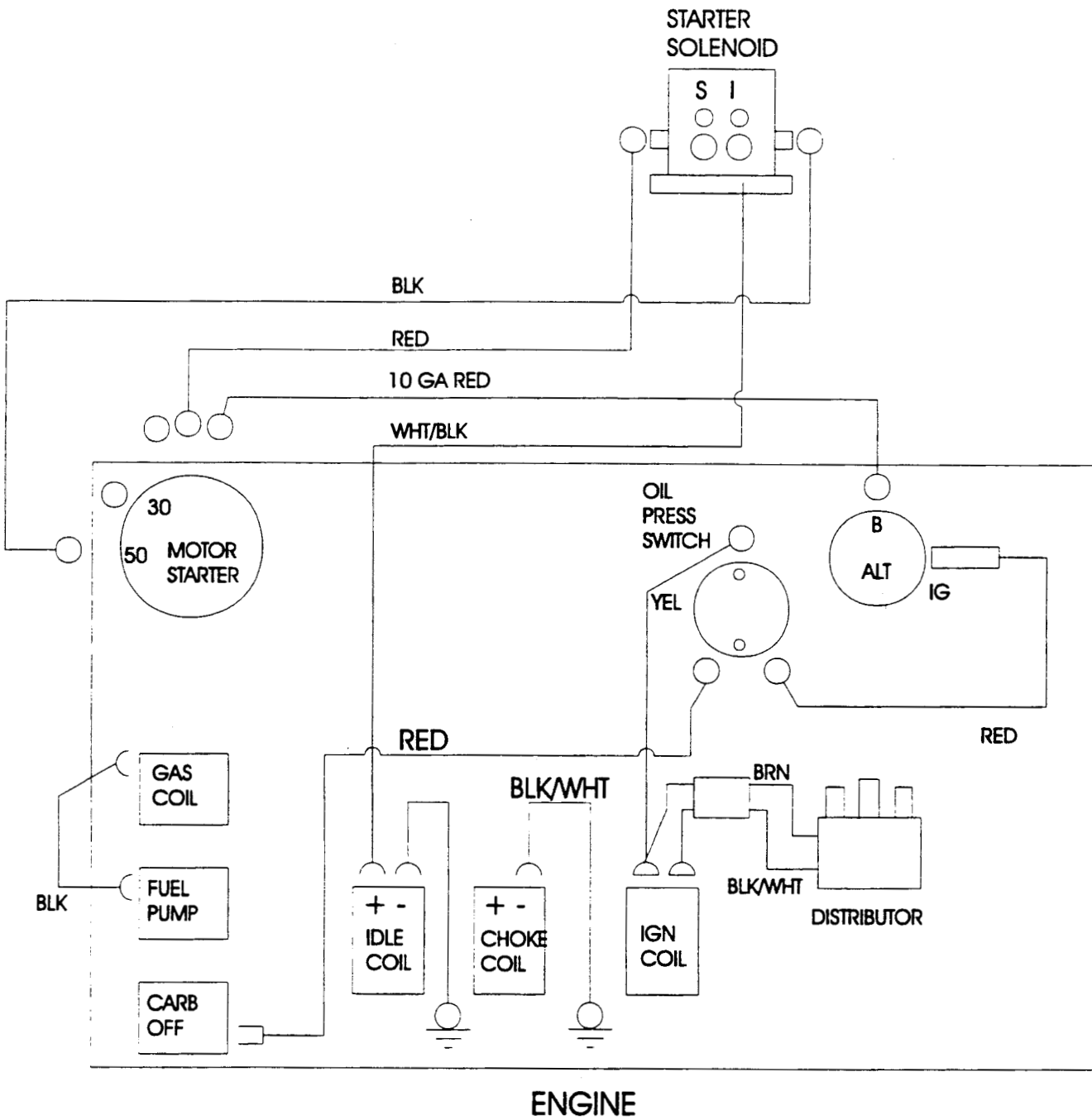

Figure 6-17: Kubota Gas Engine Diagram

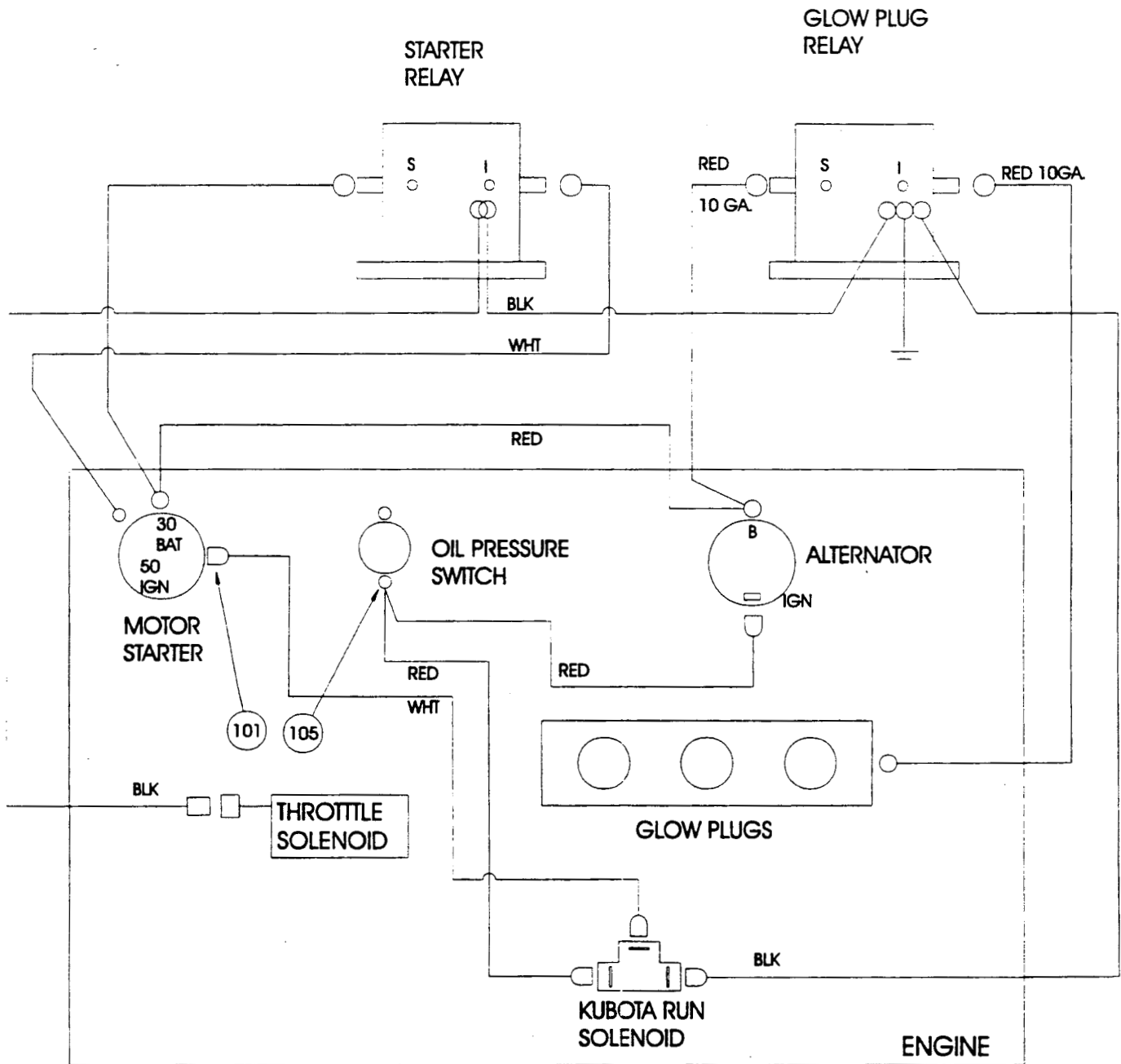

Figure 6-18: Kubota Diesel Engine Diagram

## 7.0 Introduction

This section lists and illustrates the replaceable assemblies and parts of the LX50 Work Platform, as manufactured by UpRight, Inc.

Each parts list contains the component parts for that assembly indented to show relationship where applicable.

## 7.1 Index

Assembly	Page
<b>Final Assembly, LX50, Two Wheel Drive Gas</b>	
067546-000 .....	7-4
<b>Final Assembly, LX50, Two Wheel Drive Diesel</b>	
067547-000 .....	7-4
<b>Final Assembly, LX50 Four Wheel Drive Gas</b>	
067548-000 .....	7-10
<b>Final Assembly, LX50 Four Wheel Drive Diesel</b>	
067549-000 .....	7-10
<b>Final Assembly, LX50 Dual Deck, Two Wheel Drive Gas</b>	
067408-000 .....	7-16
<b>Final Assembly, LX50 Dual Deck, Two Wheel Drive Diesel</b>	
067409-000 .....	7-16
<b>Final Assembly, LX50 Dual Deck, Four Wheel Drive Gas</b>	
067410-000 .....	7-22
<b>Final Assembly, LX 50 Dual Deck, Four Wheel Drive Diesel</b>	
067411-000 .....	7-22
<b>Basic Assembly, LX50, Two Wheel Drive Gas/Diesel</b>	
067508-000 .....	7-28
<b>Basic Assembly, LX50, Four Wheel Drive Gas/Diesel</b>	
067509-000 .....	7-29
<b>Basic Assembly, LX50 Dual Deck, Two Wheel Drive Gas/Diesel</b>	
067419-000 .....	7-30
<b>Basic Assembly, LX50 Dual Deck, Four Wheel Drive Gas/Diesel</b>	
067420-000 .....	7-31
<b>Chassis Assembly, LX50, Two Wheel Drive Gas/Diesel</b>	
067518-001 .....	7-32
<b>Chassis Assembly, LX50, Four Wheel Drive Gas/Diesel</b>	
067519-001 .....	7-34
<b>Scissor Linkage Assembly, LX50</b>	
067517-000 .....	7-36
<b>Scissor Linkage Assembly, LX50 Dual Deck</b>	
067424-000 .....	7-38
<b>Control Module Assembly, LX50, Two Wheel Drive Gas</b>	
067521-000 .....	7-40
<b>Control Module Assembly, LX50, Two Wheel Drive Diesel</b>	
067521-001 .....	7-42
<b>Control Module Assembly, LX50, Four Wheel Drive Gas</b>	
067521-002 .....	7-44
<b>Control Module Assembly, LX50, Four Wheel Drive Diesel</b>	
067521-003 .....	7-46
<b>Control Module Assembly, LX50, Two Wheel Drive Gas Dual Deck</b>	
067521-004 .....	7-48
<b>Control Module Assembly, LX50, Two Wheel Drive Diesel Dual Deck</b>	
067521-005 .....	7-50
<b>Control Module Assembly, LX50, Four Wheel Drive Gas Dual Deck</b>	
067521-006 .....	7-52

Assembly	Page
<b>Control Module Assembly, LX50, Four Wheel Drive Diesel Dual Deck</b>	
067521-007 .....	7-54
<b>Power Module Assembly, LX50, Gas</b>	
067522-001 .....	7-56
<b>Power Module Assembly, LX50, Diesel</b>	
067522-002 .....	7-58
<b>Engine Assembly, LX50, Kubota Gas</b>	
067523-001 .....	7-60
<b>Engine Assembly, LX50, Kubota Diesel</b>	
067523-002 (Up to serial #2218) .....	7-64
<b>Engine Assembly, LX50, Kubota Diesel</b>	
067523-002 (Serial #2219 to current) .....	7-68
<b>Valve Block Assembly, LX50, Two Wheel Drive</b>	
067524-000 .....	7-72
<b>Valve Block Assembly, LX50, Four Wheel Drive</b>	
067524-001 .....	7-73
<b>Control Box Assembly, LX50, Four Wheel Drive Gas/Four Wheel Drive Gas Dual Deck/Two Wheel Drive Gas</b>	
067527-000 .....	7-74
<b>Control Box Assembly, LX50, Four Wheel Drive Diesel/Four Wheel Drive Diesel Dual Deck/Two Wheel Drive Diesel</b>	
067527-001 .....	7-78
<b>Control Box Assembly, LX50, Two Wheel Drive, Gas Dual Deck</b>	
067527-002 .....	7-82
<b>Control Box Assembly, LX50, Two Wheel Drive, Diesel Dual Deck</b>	
067527-003 .....	7-86
<b>Panel Assembly, LX50, Four Wheel Drive, Gas &amp; Dual Fuel</b>	
067529-000 .....	7-90
<b>Panel Assembly, LX50, Four Wheel Drive, Diesel</b>	
067529-001 .....	7-90
<b>Panel Assembly, LX50, Two Wheel Drive, Diesel</b>	
067529-002 .....	7-90
<b>Panel Assembly, LX50, Two Wheel Drive, Gas &amp; Dual Fuel</b>	
067529-003 .....	7-90
<b>Controller Assembly, LX50</b>	
067528-000 .....	7-92
<b>Guardrail Assembly, LX50, Without Slideout Deck</b>	
067530-005 .....	7-94
<b>Guardrail Assembly, LX50, With Slideout Deck</b>	
067530-004 .....	7-96
<b>Guardrail Assembly, LX50, Dual Deck</b>	
030867-300 .....	7-98
<b>Slideout Deck Assembly, LX50 Dual Deck</b>	
067886-001 .....	7-100
<b>Slideout Deck Assembly-Rear, LX50 Dual Deck</b>	
067886-002 .....	7-102
<b>Hose Assembly, LX50, Two Wheel Drive</b>	
067533-012 .....	7-104
<b>Hose Assembly, LX50, Four Wheel Drive</b>	
067533-013 .....	7-106
<b>Label Kit, LX50, Two Wheel Drive</b>	
Gas 067532-020 .....	7-108
Diesel 067532-021 .....	7-108
<b>Label Kit, LX50, Four Wheel Drive</b>	
Gas 067532-022 .....	7-108
Diesel 067532-023 .....	7-108



Assembly	Page
<b>Label Kit, LX50, Two Wheel Drive Dual Deck</b>	
Gas 067532-038 .....	7-110
Diesel 067532-039 .....	7-110
<b>Label Kit, LX50, Four Wheel Drive Dual Deck</b>	
Gas 067532-040 .....	7-110
Diesel 067532-041 .....	7-110
<b>Dual Fuel Assembly</b>	
Standard 067905-000 .....	7-112
Dual Deck 067905-001 .....	7-112
<b>Generator Option, LX, Dual Fuel</b>	
067848-000 .....	7-116
<b>Generator Option, LX, Diesel</b>	
067849-000 .....	7-118
<b>Removable Controller Option, LX50</b>	
061898-002 .....	7-120
<b>Horn Option, LX50</b>	
067908-000 .....	7-122
<b>Amber Beacon Option</b>	
067947-000 .....	7-123
<b>Power to Platform Option, LX50</b>	
067907-000 .....	7-124
<b>Outrigger Option, LX50</b>	
067950-000 .....	7-126
<b>Outrigger Assembly, LX50 Dual Deck</b>	
067950-001 .....	7-126
<b>Control Box Assembly/Outrigger, LX50</b>	
067957-000 .....	7-128
<b>Control Box Assembly/Outrigger, LX50 Dual Deck</b>	
067957-001 .....	7-132
<b>Valve Block Assembly/Outrigger, LX50</b>	
067956-000 .....	7-135
<b>Controller Assembly/Outrigger, LX50</b>	
067954-000 .....	7-136
<b>Motion Alarm Option</b>	
067909-000 .....	7-137

NOTES:

## Illustrated Parts Breakdown

FINAL ASSEMBLY, LX50  
Two Wheel Drive GAS  
067546-000

ITEM	PART	DESCRIPTION	QTY.
1	067508-000	BASIC ASSY	1
2	067528-000	CONTROLLER ASSY	1
3	067536-002	CONTROL CABLE ASSY	1
4	067532-020	LABEL-KIT	1
5	067533-012	HOSE-KIT	1
6	067530-005	GUARDRAIL	1
7	067522-001	POWER MODULE	1
8	067521-000	CONTROL MODULE	1
9	067534-002	HYD SCHM.	REF
10	067535-003	ELEC. SCHM.	REF
12	067692-000	CLIP, CABLE RETAINER	8
13	020032-001	TEE, #4MJ-#4MJ-#4MJ	1
14	029945-013	LEVEL SENSOR	1
15	011252-006	SCRW, 1/4-20 X 3/4	4
16	011248-004	LOCKNUT, 1/4-20 UNC	4
17	065373-006	MAGNET	2
18	065373-005	SWITCH	2
19	067913-000	ALUM. SW. PAD	1
20	026551-005	RIVET 1/8 X 1/4 GRIP	8
21	029447-099	CABLE 3 COND. 16 GA.	10 FT
22	029620-002	CONN. BUTT 16-14 GA.	8
23	063497-001	MERCURY SWITCH	2
24	013919-013	CLAMP	2
25	014996-004	WASHER, 1/4 SAE	4
26	012865-099	WIRE LOOM 3/4 DIA	8
*	013283-002	CABLE MOUNT	6
*	067758-099	NYLON HOSE GUARD	11
30	067863-000	SWITCH MOUNT	1
31	011919-006	FITTING PLUG 12MP	1
*	015963-099	STRAP MATL	13
*	015964-000	STRAP HEAD	12
*	020398-012	HOSE CLAMP	6
102	062125-002	BATTERY CABLE ASSY	2
103	029616-003	TERMINAL, FEMALE PUSH	1
104	029616-002	TERMINAL, FEMALE PUSH	4
105	029601-019	TERMINAL, RING	1
106	029610-002	TERMINAL, FORK	5
107	029601-011	TERMINAL, RING	3
108	005469-099	WIRE, 9 CONDUCTOR	14'
109	029480-099	WIRE, 10GA STRD RED	14'
110	067536-001	CONTROL CABLE ASSY	REF
112	029825-002	DIODE	1
113	029451-099	WIRE, 16 AWG WHITE	2
114	029601-039	CONN RING 5/16 10-12	2
115	029481-099	WIRE, 10 AWG BLK	FT 5.5

FINAL ASSEMBLY, LX50  
Two Wheel Drive DIESEL  
067547-000

ITEM	PART	DESCRIPTION	QTY.
1	067508-000	BASIC ASSY	1
2	067528-000	CONTROLLER ASSY	1
3	067536-002	CONTROL CABLE ASSY	1
4	067532-021	LABEL-KIT	1
5	067533-012	HOSE-KIT	1
6	067530-005	GUARDRAIL	1
7	067522-002	POWER MODULE	1
8	067521-001	CONTROL MODULE	1
9	067534-002	HYD SCHM.	REF
10	067535-002	ELEC. SCHM.	REF
12	067692-000	CLIP, CABLE RETAINER	8
13	020032-001	TEE, #4MJ-#4MJ-#4MJ	1
14	029945-013	LEVEL SENSOR	1
15	011252-006	SCRW, 1/4-20 X 3/4	4
16	011248-004	LOCKNUT, 1/4-20 UNC	5
17	065373-006	MAGNET	2
18	065373-005	SWITCH	2
19	067913-000	ALUM. SW. PAD	1
20	026551-005	RIVET 1/8 X 1/4 GRIP	8
21	029447-099	CABLE 3 COND. 16 GA.	10 FT
22	029620-002	CONN. BUTT 16-14 GA.	8
23	063497-001	MERCURY SWITCH	2
24	013919-013	CLAMP	2
25	014996-004	WASHER, 1/4 SAE FLAT	4
26	012865-099	WIRE LOOM 3/4 DIA	8
27	013283-002	CABLE MOUNT	6
28	067758-099	NYLON HOSE GUARD	11
30	067863-000	SWITCH MOUNT	1
31	011919-006	FITTING PLUG 12MP	1
33	015963-099	STRAP MATL	13
34	015964-000	STRAP HEAD	12
35	020398-012	HOSE CLAMP	6
102	062125-002	BATTERY CABLE ASSY	2
103	029616-003	TERMINAL, FEMALE PUSH	1
104	029616-002	TERMINAL, FEMALE PUSH	2
105	029601-019	TERMINAL, RING	1
106	029610-002	TERMINAL, FORK	2
107	029601-011	TERMINAL, RING	2
108	005469-099	WIRE, 9 CONDUCTOR	14'
109	029480-099	WIRE, 10GA STRD RED	14'
110	067536-001	CONTROL CABLE ASSY	REF
112	029825-002	DIODE	1
113	029451-099	WIRE, 16AWG WHITE	2
114	029601-039	CONN RING 5/16 10-12	2
115	029481-099	WIRE, 10AWG BLK	FT 5.5
116	029617-002	CONN MALE PUSH 16-14GA. .25	2

\* Not Shown

# Illustrated Parts Breakdown

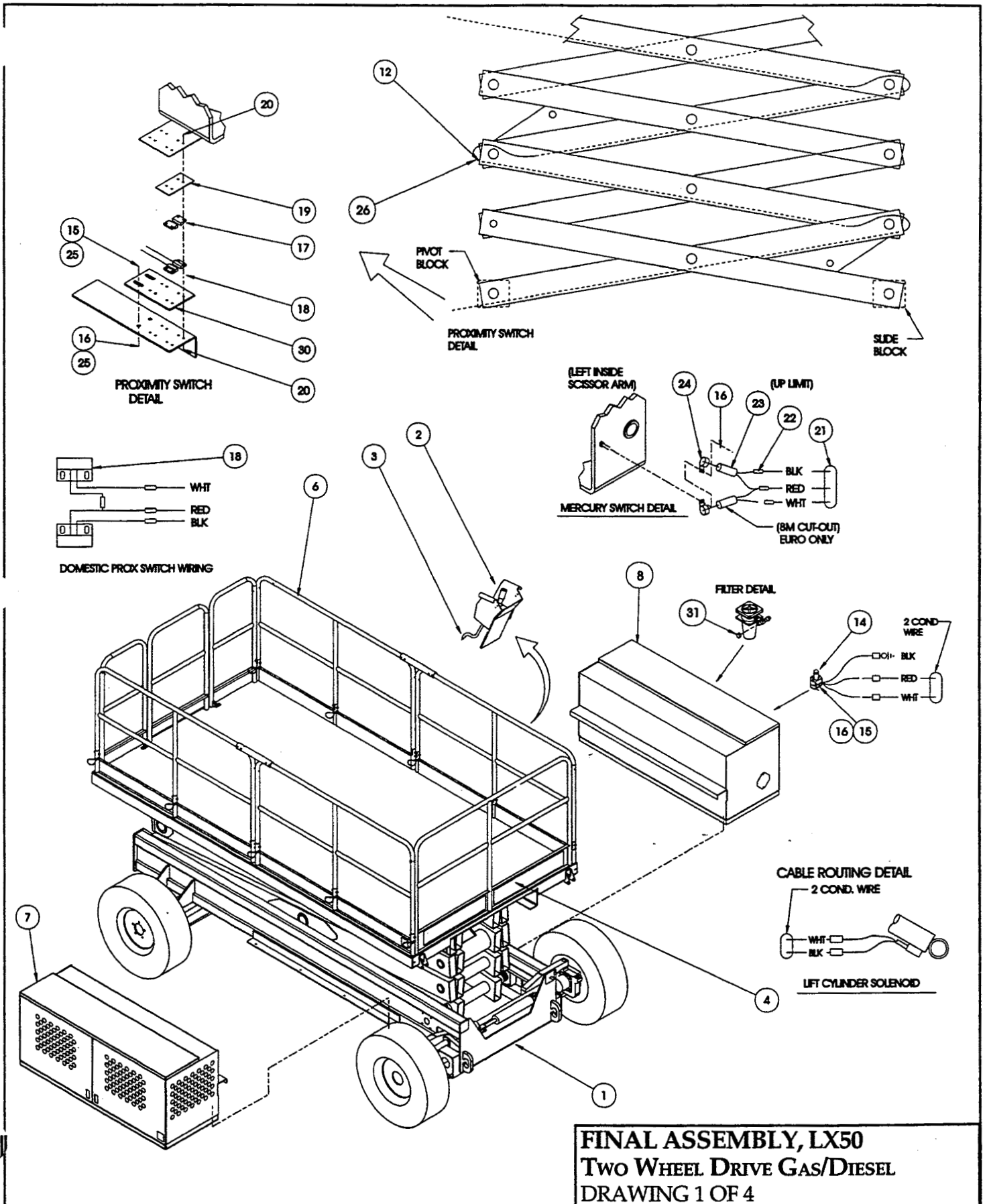

**FINAL ASSEMBLY, LX50**  
**TWO WHEEL DRIVE GAS/DIESEL**  
**DRAWING 1 OF 4**

# Illustrated Parts Breakdown

**FINAL ASSEMBLY, LX50**  
**TWO WHEEL DRIVE GAS**  
**DRAWING 2 OF 4**

**GAS**

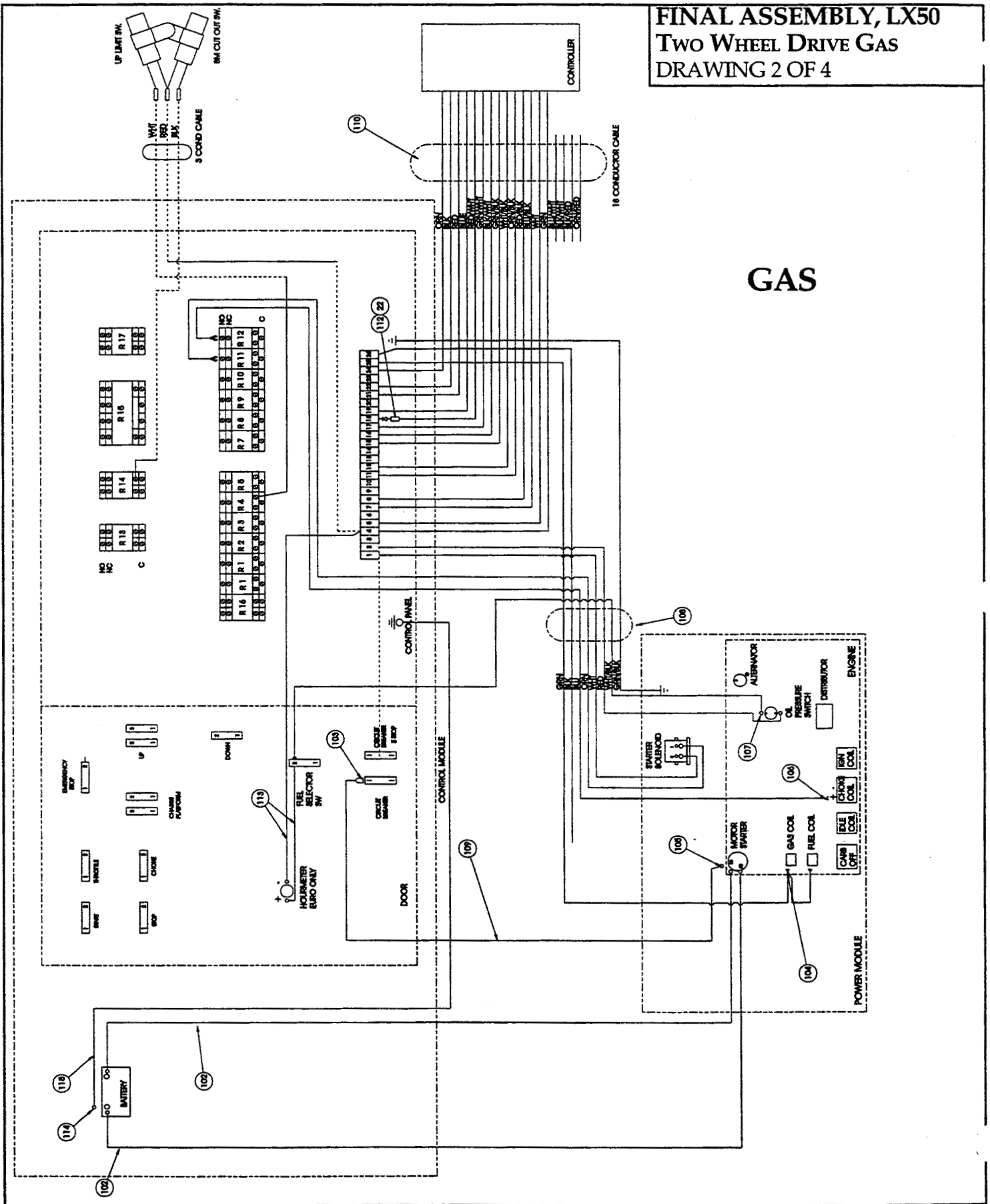

# Illustrated Parts Breakdown

**FINAL ASSEMBLY, LX50  
Two Wheel Drive Diesel  
DRAWING 3 OF 4**

**UP TO SERIAL  
NUMBER 2218**

**DIESEL**

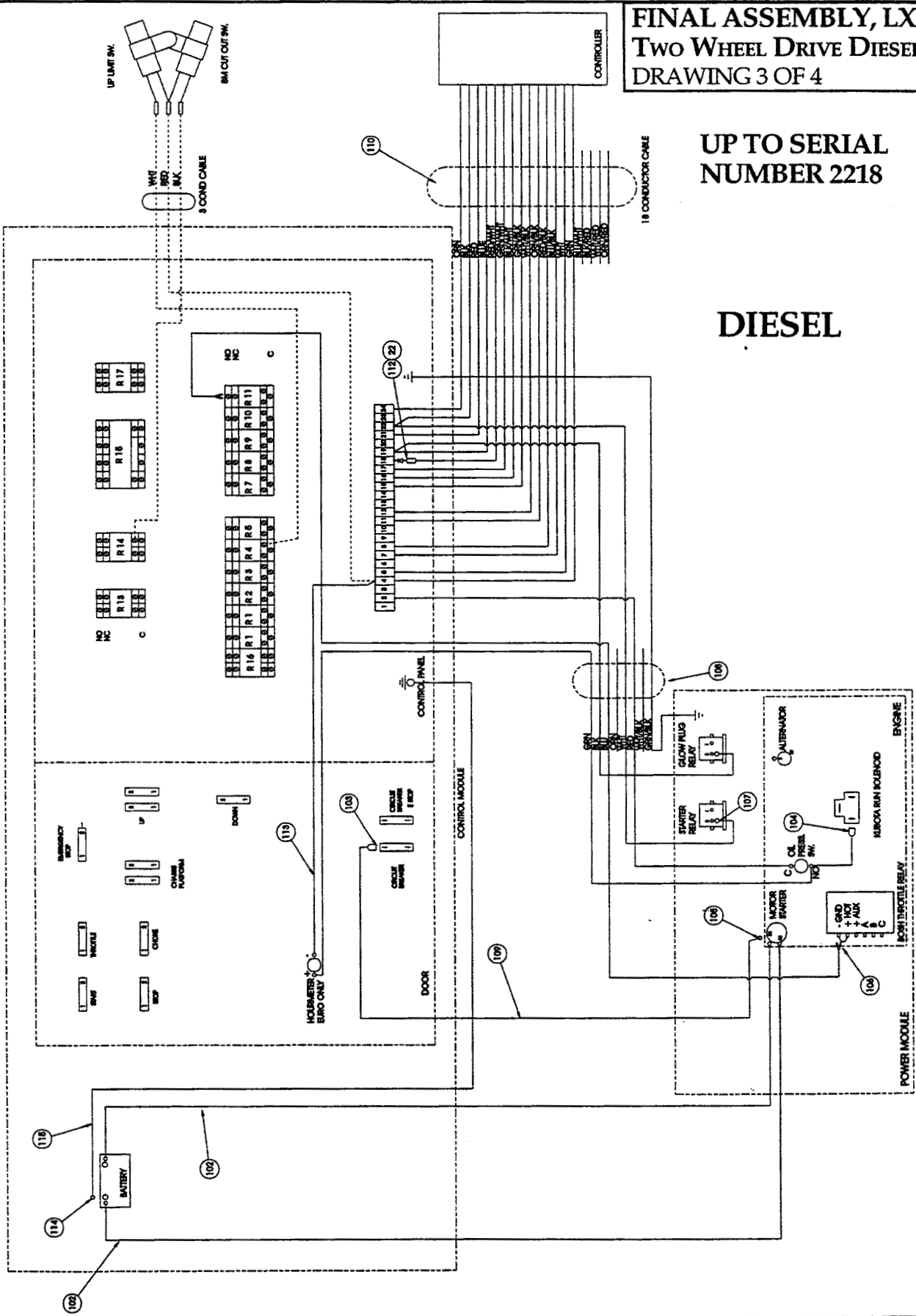

# Illustrated Parts Breakdown

**FINAL ASSEMBLY, LX50**  
**TWO WHEEL DRIVE DIESEL**  
**DRAWING 4 OF 4**

**SERIAL NUMBER 2219**  
**TO CURRENT**

**DIESEL**

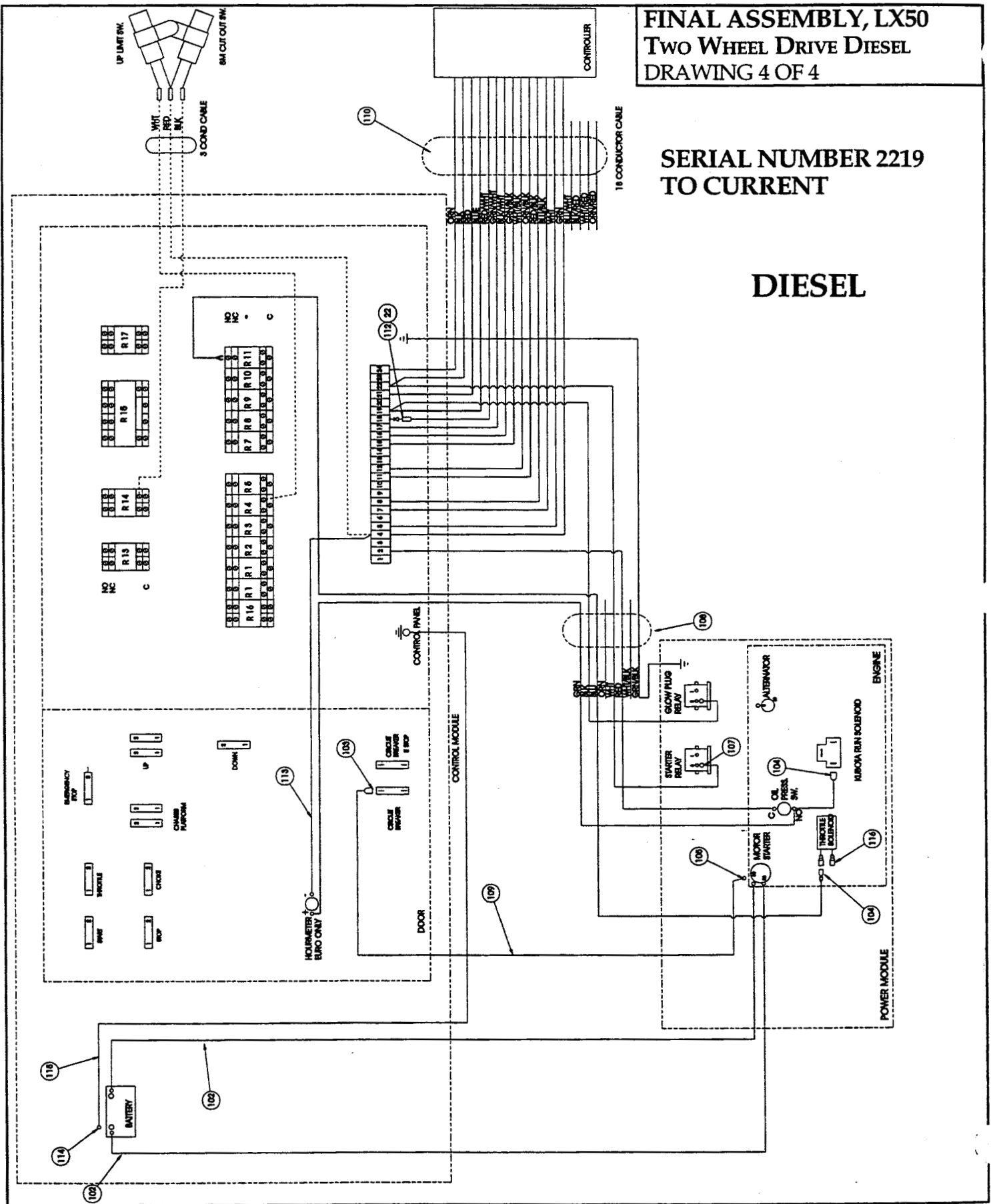

NOTES:



# Illustrated Parts Breakdown

FINAL ASSEMBLY, LX50  
FOUR WHEEL DRIVE GAS  
067548-000

ITEM	PART	DESCRIPTION	QTY.
1	067509-000	BASIC ASSY	1
2	067528-000	CONTROLLER ASSY	1
3	067536-002	CONTROL CABLE ASSY	1
4	067532-022	LABEL-KIT	1
5	067533-013	HOSE-KIT	1
6	067530-005	GUARDRAIL	1
7	067522-001	POWER MODULE	1
8	067521-002	CONTROL MODULE	1
9	067534-003	HYD SCHM.	REF
10	067535-000	ELEC. SCHM.	REF
12	067699-000	CHANNEL HOSE CLAMP	2
13	011248-004	LOCKNUT, 1/4-20 ESNA	8
14	014996-004	WASHER, 1/4 S.A.E.	8
15	067692-000	CLIP, CABLE RETAINER	8
16	020032-001	TEE, #4MJ-#4MJ-#4MJ	2
17	029945-013	LEVEL SENSOR	1
18	011252-006	SCRW, 1/4-20 X 3/4	4
19	012865-099	WIRE LOOM 3/4 DIA	8
20	065373-006	MAGNET	2
21	065373-005	SWITCH	2
22	067913-000	ALUM. SW. PAD	1
23	026551-005	RIVET 1/8 X 1/4 GRIP	8
24	029447-099	CABLE 3 COND. 16 GA.	10 FT
25	029620-002	CONN. BUTT 16-14 GA.	9
26	063497-001	MERCURY SWITCH	2
27	013919-013	CLAMP	2
28	067758-099	HOSE GUARD	14.7
30	067863-000	SWITCH MOUNT	1
*	013283-002	CABLE MOUNT	6
32	011923-007	FITTING ADA 12MP-4FP	1
33	011940-004	FITTING 90 4MP-4MJ	1
*	015963-099	STRAP MATL	11
*	015964-000	STRAP HEAD	9
*	020398-012	HOSE CLAMP	6
102	062125-002	BATTERY CABLE ASSY	2
103	029616-003	TERMINAL, FEMALE PUSH	1
104	029616-002	TERMINAL, FEMALE PUSH	4
105	029601-019	TERMINAL, RING	1
106	029610-002	TERMINAL, FORK	5
107	029601-011	TERMINAL, RING	3
108	005469-099	WIRE, 9 CONDUCTOR	14'
109	029480-099	WIRE, 10GA STRD RED	14'
110	067536-001	CONTROL CABLE ASSY	REF
111	029496-099	WIRE, 2 CONDUCTOR	10'
112	029825-002	DIODE	1
113	029451-099	WIRE, 16 AWG WHITE	2
114	029601-039	CONN RING 5/16 10-12	2
115	029481-099	WIRE, 10 AWG BLK	FT 5.5

FINAL ASSEMBLY, LX50  
FOUR WHEEL DRIVE DIESEL  
067549-000

ITEM	PART	DESCRIPTION	QTY.
1	067509-000	BASIC ASSY	1
2	067528-000	CONTROLLER ASSY	1
3	067536-002	CONTROL CABLE ASSY	1
4	067532-023	LABEL-KIT	1
5	067533-013	HOSE-KIT	1
6	067530-005	GUARDRAIL	1
7	067522-002	POWER MODULE	1
8	067521-003	CONTROL MODULE	1
9	067534-003	HYD SCHM.	REF
10	067535-001	ELEC. SCHM.	REF
12	067699-000	HOSE CLAMP CHANNEL	2
13	011248-004	LOCKNUT 1/4-20 ESNA	8
14	014996-004	WASHER 1/4" SAE	8
15	067692-000	CLIP, CABLE RETAINER	8
16	020032-001	TEE, #4MJ-#4MJ-#4MJ	2
17	029945-013	LEVEL SENSOR	1
18	011252-006	SCRW, 1/4-20 X 3/4	4
19	012865-099	WIRE LOOM 3/4 DIA	8
20	065373-006	MAGNET	2
21	065373-005	SWITCH	2
22	067913-000	ALUM. SW. PAD	1
23	026551-005	RIVET 1/8 X 1/4 GRIP	8
24	029447-099	CABLE 3 COND. 16 GA.	10 FT
25	029620-002	CONN. BUTT 16-14 GA.	5
26	063497-001	MERCURY SWITCH	2
27	013919-013	CLAMP	2
28	067758-099	HOSE GUARD	14.7
30	067863-000	SWITCH MOUNT	1
*	013283-002	CABLE MOUNT	6
32	011923-007	FITTING ADA 12MP-4FP	1
33	011940-004	FITTING 90 4MP-4MJ	1
*	015963-099	STRAP MATL	11
*	015964-000	STRAP HEAD	9
*	020398-012	HOSE CLAMP	6
102	062125-002	BATTERY CABLE ASSY	2
103	029616-003	TERMINAL, FEMALE PUSH	1
104	029616-002	TERMINAL, FEMALE PUSH	2
105	029601-019	TERMINAL, RING	1
106	029610-002	TERMINAL, FORK	4
107	029601-011	TERMINAL, RING	2
108	005469-099	WIRE, 9 CONDUCTOR	14'
109	029480-099	WIRE, 10GA STRD RED	14'
110	067536-001	CONTROL CABLE ASSY	REF
111	029496-099	WIRE, 2 CONDUCTOR	10'
112	029825-002	DIODE	1
113	029451-099	WIRE, 16 AWG WHITE	2
114	029601-039	CONN RING 5/16 10-12	2
115	029481-099	WIRE 10 AWG BLK	FT 5.5
116	029617-002	CONN MALE PUSH 16-14 GA. .25	2

\* Not Shown

# Illustrated Parts Breakdown

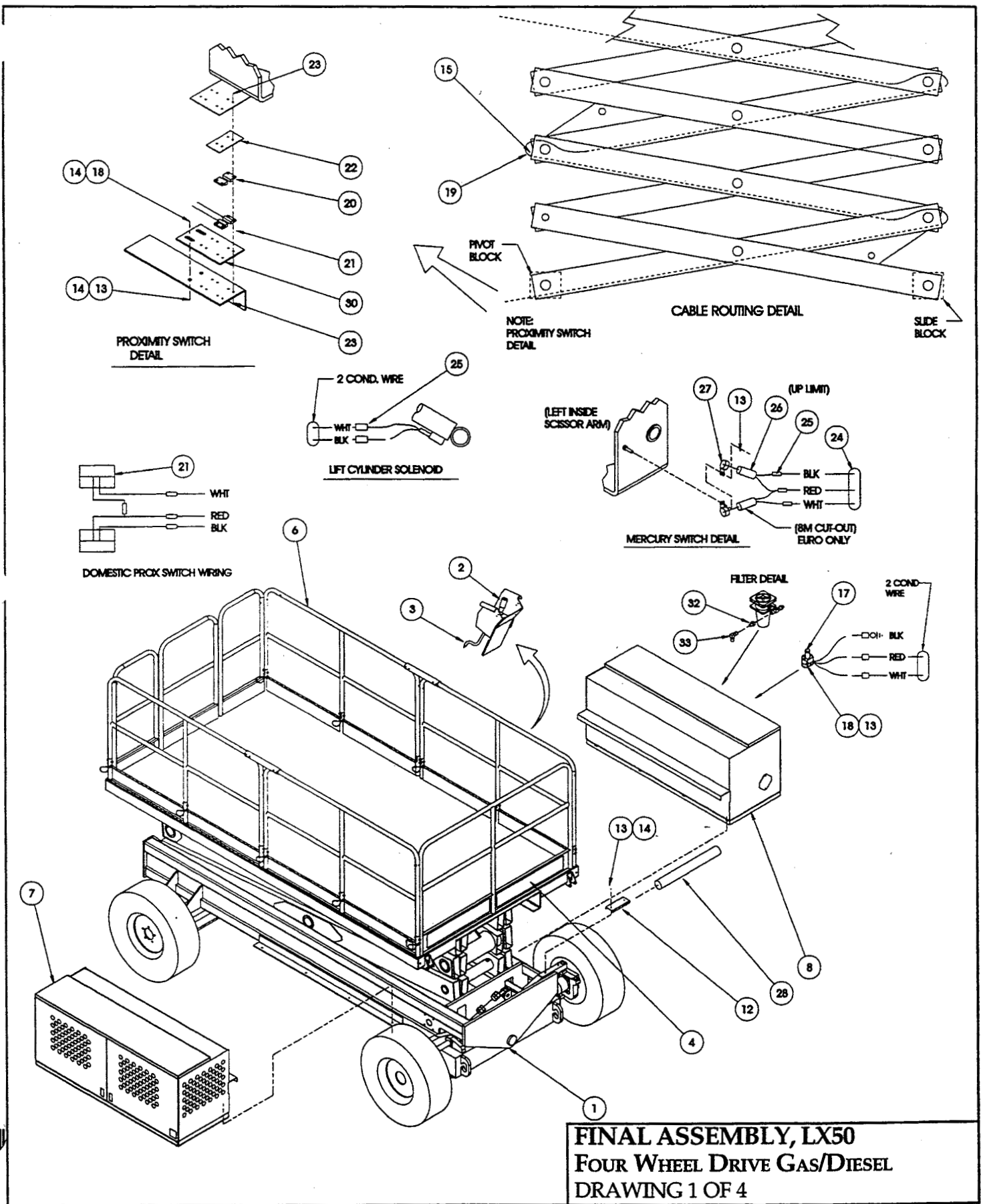

# Illustrated Parts Breakdown

**FINAL ASSEMBLY, LX50  
FOUR WHEEL DRIVE GAS  
DRAWING 2 OF 4**

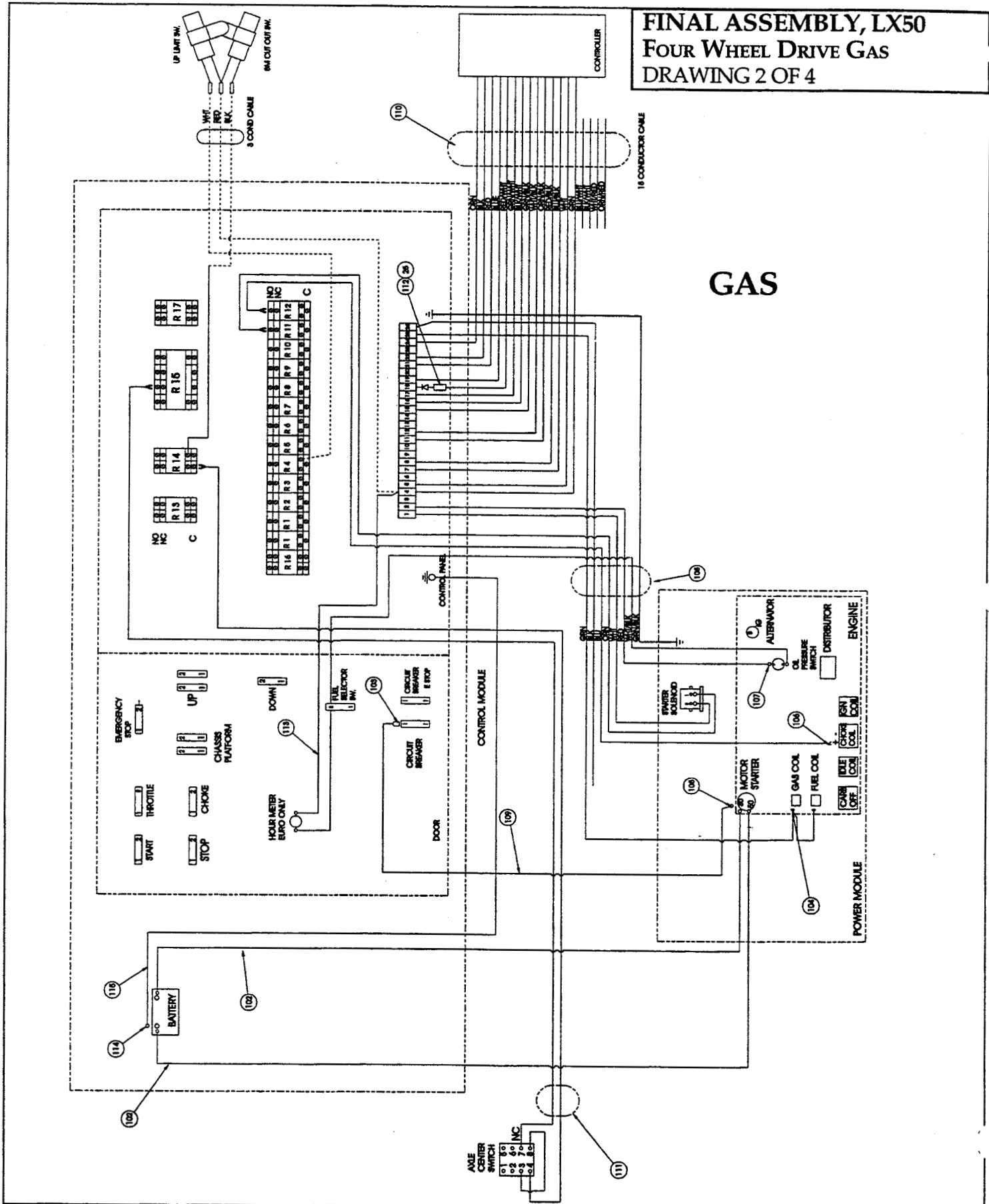

**GAS**

# Illustrated Parts Breakdown

**FINAL ASSEMBLY, LX50  
FOUR WHEEL DRIVE DIESEL  
DRAWING 3 OF 4**

**UP TO SERIAL  
NUMBER 2218**

**DIESEL**

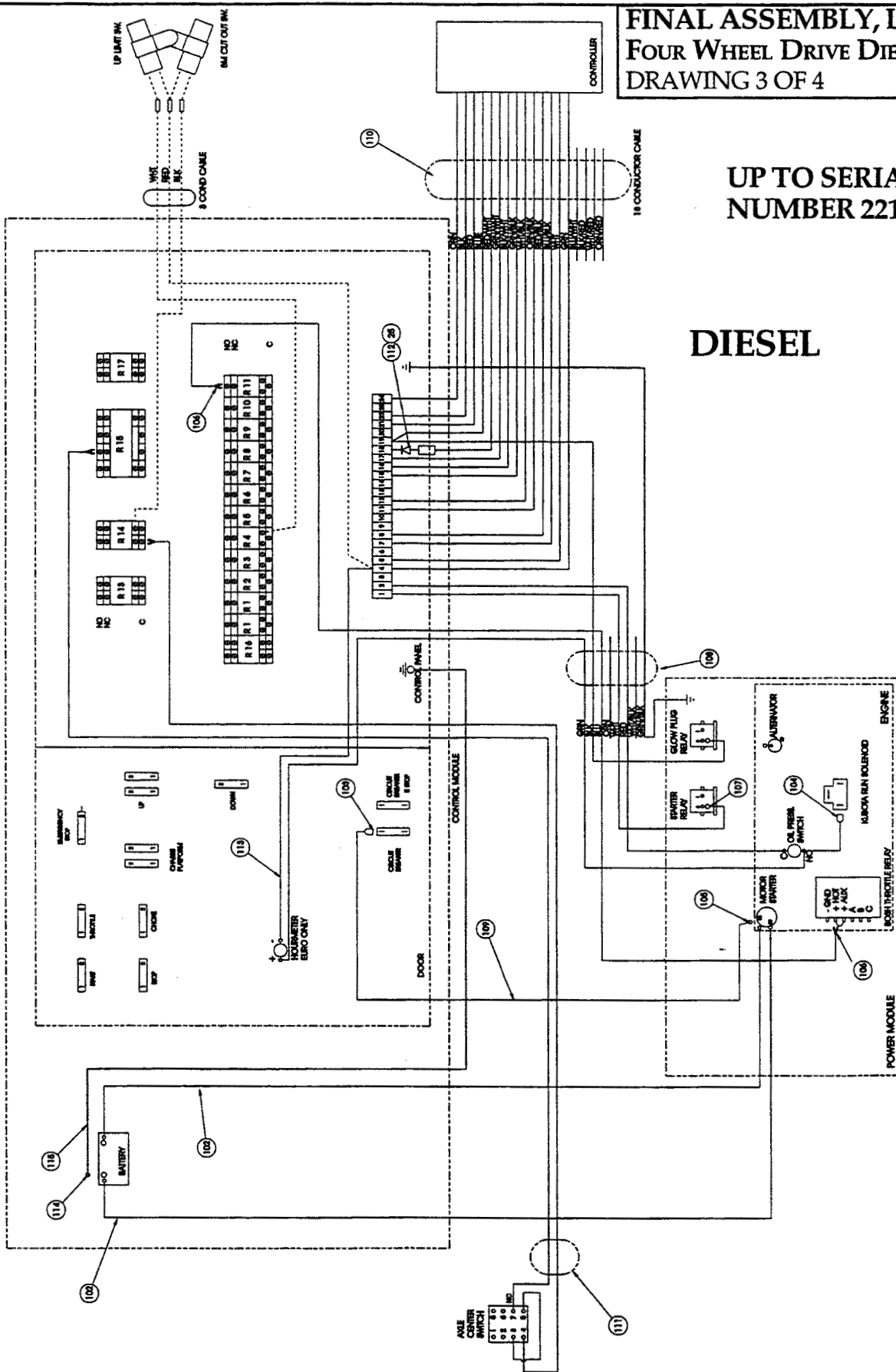

**FINAL ASSEMBLY, LX50  
FOUR WHEEL DRIVE DIESEL  
DRAWING 4 OF 4**

**SERIAL NUMBER 2219  
TO CURRENT**

**DIESEL**

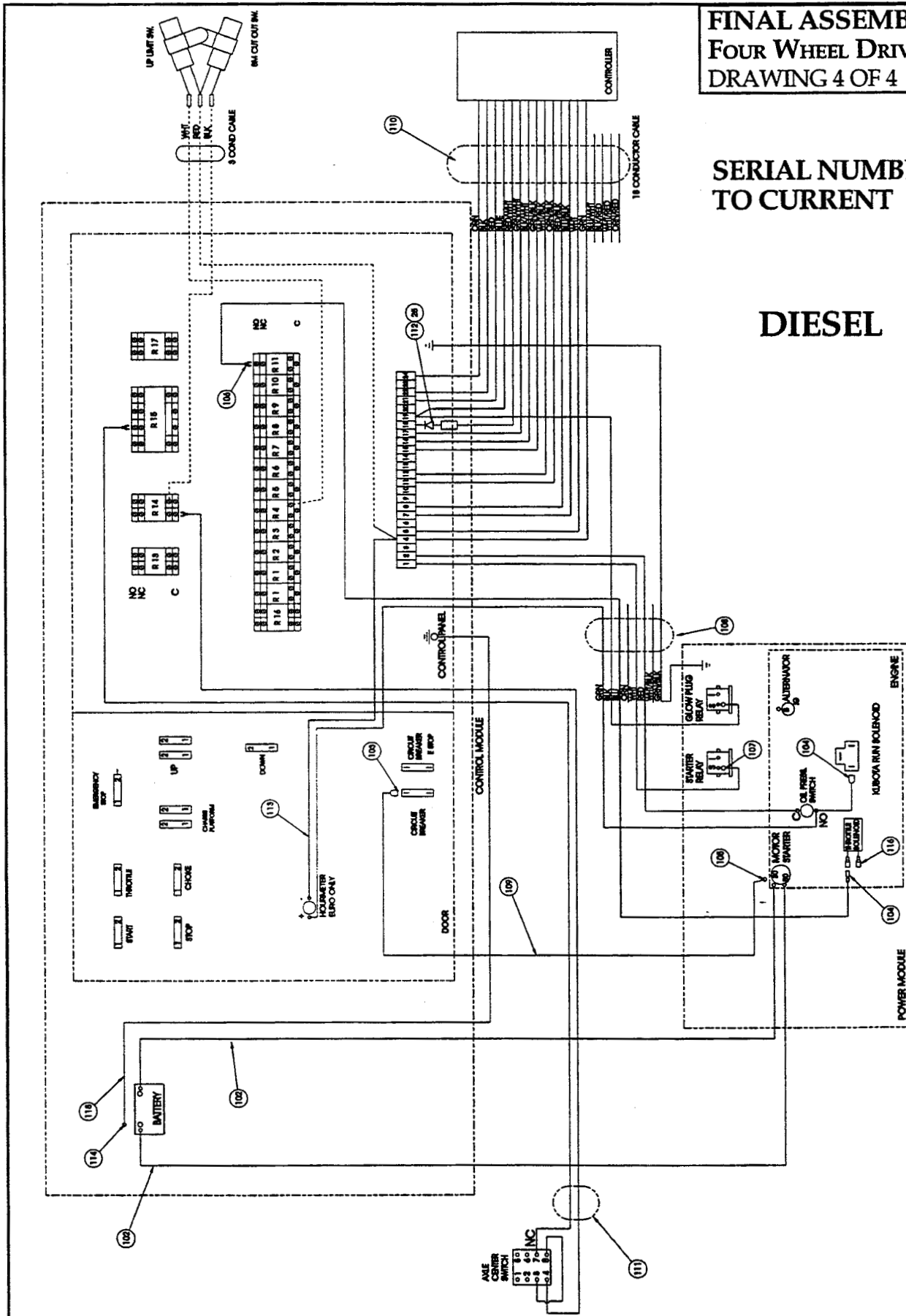

NOTES:

**FINAL ASSEMBLY, LX50 DUAL DECK  
Two WHEEL DRIVE GAS**  
067408-000

ITEM	PART	DESCRIPTION	QTY.
1	067419-000	BASIC ASSY	1
2	067528-000	CONTROLLER ASSY	1
3	067536-002	CONTROL CABLE ASSY	1
4	067532-038	LABEL-KIT	1
5	067533-012	HOSE-KIT	1
6	030867-300	GUARDRAIL	1
7	067522-001	POWER MODULE	1
8	067521-004	CONTROL MODULE	1
9	067534-002	HYD SCHM.	REF
10	067535-027	ELEC. SCHM.	REF
11	067866-001	SLIDE-OUT DECK INSTL	1
12	067692-000	CLIP, CABLE RETAINER	8
13	020032-001	TEE, #4MJ-#4MJ-#4MJ	1
14	029945-013	LEVEL SENSOR	1
15	011252-006	SCRW, 1/4-20 X 3/4	4
16	011248-004	LOCKNUT, 1/4-20 UNC	4
17	065373-006	MAGNET	2
18	065373-005	SWITCH	2
19	067913-000	ALUM. SW. PAD	1
20	026551-005	RIVET 1/8 X 1/4 GRIP	8
21	029447-099	CABLE 3 COND. 16 GA.	10 FT
22	029620-002	CONN. BUTT 16-14 GA.	8
23	063497-001	MERCURY SWITCH	2
24	013919-013	CLAMP	2
25	014996-004	WASHER, 1/4 SAE	4
26	012865-099	WIRE LOOM 3/4 DIA	8
*	013283-002	CABLE MOUNT	6
*	067758-099	NYLON HOSE GUARD	11
30	067863-000	SWITCH MOUNT	1
31	011919-006	FITTING PLUG 12MP	1
*	015963-099	STRAP MATL	13
*	015964-000	STRAP HEAD	12
*	020398-012	HOSE CLAMP	6
36	067950-001	OUTRIGGER OPTION	1
37	067866-002	SLIDE OUT DECK -REAR	1
102	062125-002	BATTERY CABLE ASSY	2
103	029616-003	TERMINAL, FEMALE PUSH	1
104	029616-002	TERMINAL, FEMALE PUSH	4
105	029601-019	TERMINAL, RING	1
106	029610-002	TERMINAL, FORK	5
107	029601-011	TERMINAL, RING	3
108	005469-099	WIRE, 9 CONDUCTOR	14'
109	029480-099	WIRE, 10GA STRD RED	14'
110	067536-001	CONTROL CABLE ASSY	REF
112	029825-002	DIODE	1
113	029451-099	WIRE, 16 AWG WHITE	2
114	029601-039	CONN RING 5/16 10-12	2
115	029481-099	WIRE, 10 AWG BLK	FT 5.5

**FINAL ASSEMBLY, LX50 DUAL DECK  
Two WHEEL DRIVE DIESEL**  
067409-000

ITEM	PART	DESCRIPTION	QTY.
1	067419-000	BASIC ASSY	1
2	067528-000	CONTROLLER ASSY	1
3	067536-002	CONTROL CABLE ASSY	1
4	067532-039	LABEL-KIT	1
5	067533-012	HOSE-KIT	1
6	030867-300	GUARDRAIL	1
7	067522-002	POWER MODULE	1
8	067521-005	CONTROL MODULE	1
9	067534-002	HYD SCHM.	REF
10	067535-026	ELEC. SCHM.	REF
11	067866-001	SLIDE-OUT DECK INSTL	1
12	067692-000	CLIP, CABLE RETAINER	8
13	020032-001	TEE, #4MJ-#4MJ-#4MJ	1
14	029945-013	LEVEL SENSOR	1
15	011252-006	SCRW, 1/4-20 X 3/4	4
16	011248-004	LOCKNUT, 1/4-20 UNC	5
17	065373-006	MAGNET	2
18	065373-005	SWITCH	2
19	067913-000	ALUM. SW. PAD	1
20	026551-005	RIVET 1/8 X 1/4 GRIP	8
21	029447-099	CABLE 3 COND. 16 GA.	10 FT
22	029620-002	CONN. BUTT 16-14 GA.	8
23	063497-001	MERCURY SWITCH	2
24	013919-013	CLAMP	2
25	014996-004	WASHER, 1/4 SAE FLAT	4
26	012865-099	WIRE LOOM 3/4 DIA	8
*	013283-002	CABLE MOUNT	6
*	067758-099	NYLON HOSE GUARD	11
30	067863-000	SWITCH MOUNT	1
31	011919-006	FITTING PLUG 12MP	1
*	015963-099	STRAP MATL	13
*	015964-000	STRAP HEAD	12
*	020398-012	HOSE CLAMP	6
36	067950-001	OUTRIGGER OPTION	1
37	067866-002	SLIDE OUT DECK -REAR	1
102	062125-002	BATTERY CABLE ASSY	2
103	029616-003	TERMINAL, FEMALE PUSH	1
104	029616-002	TERMINAL, FEMALE PUSH	2
105	029601-019	TERMINAL, RING	1
106	029610-002	TERMINAL, FORK	2
107	029601-011	TERMINAL, RING	2
108	005469-099	WIRE, 9 CONDUCTOR	14'
109	029480-099	WIRE, 10GA STRD RED	14'
110	067536-001	CONTROL CABLE ASSY	REF
111	029617-002	CONN. MALE PUSH 16-14GA. .25	2
112	029825-002	DIODE	1
113	029451-099	WIRE, 16AWG WHITE	2
114	029601-039	CONN RING 5/16 10-12	2
115	029481-099	WIRE, 10AWG BLK	FT 5.5

\* Not Shown

# Illustrated Parts Breakdown

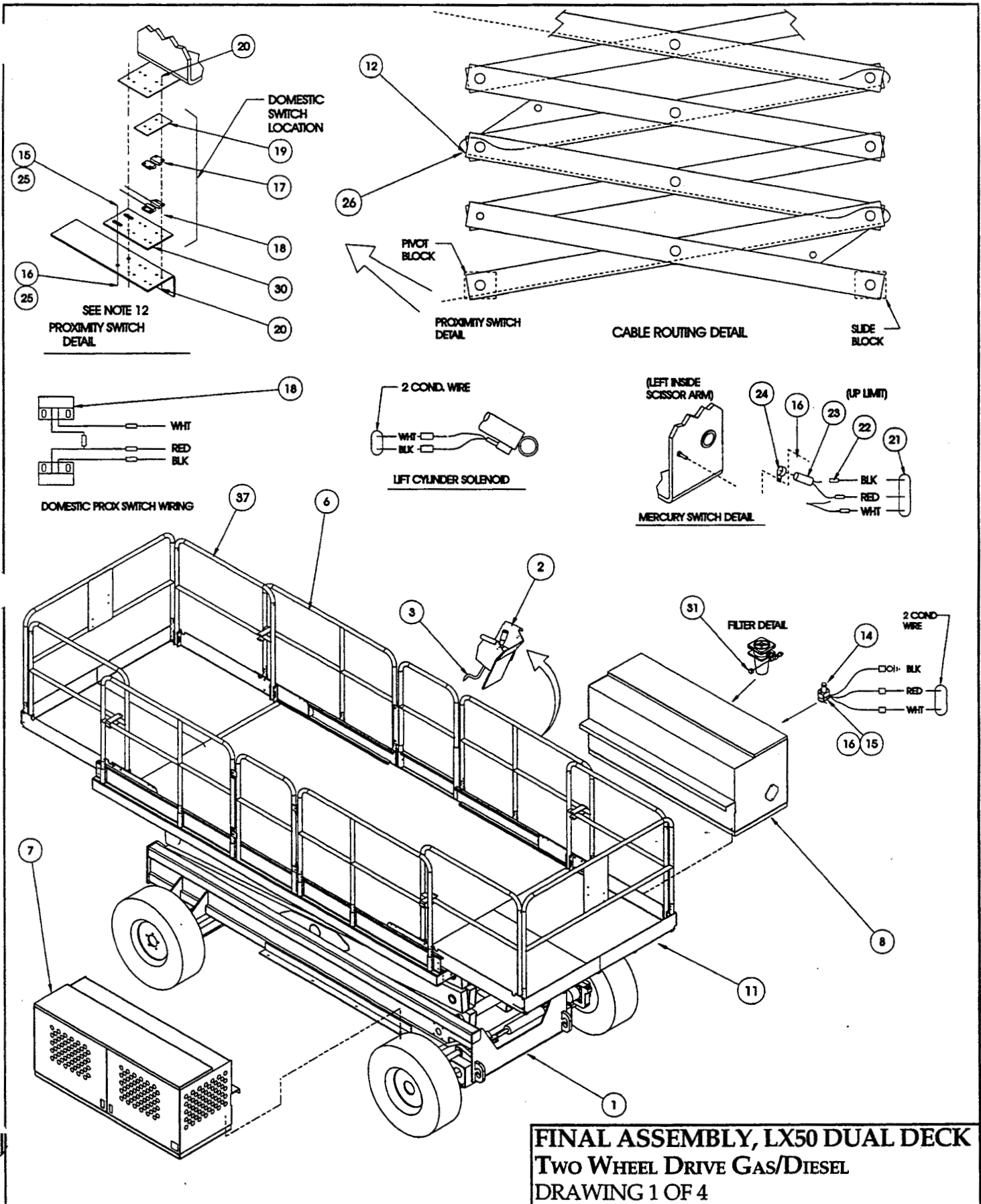



**FINAL ASSEMBLY, LX50  
DUAL DECK  
TWO WHEEL DRIVE GAS  
DRAWING 2 OF 4**

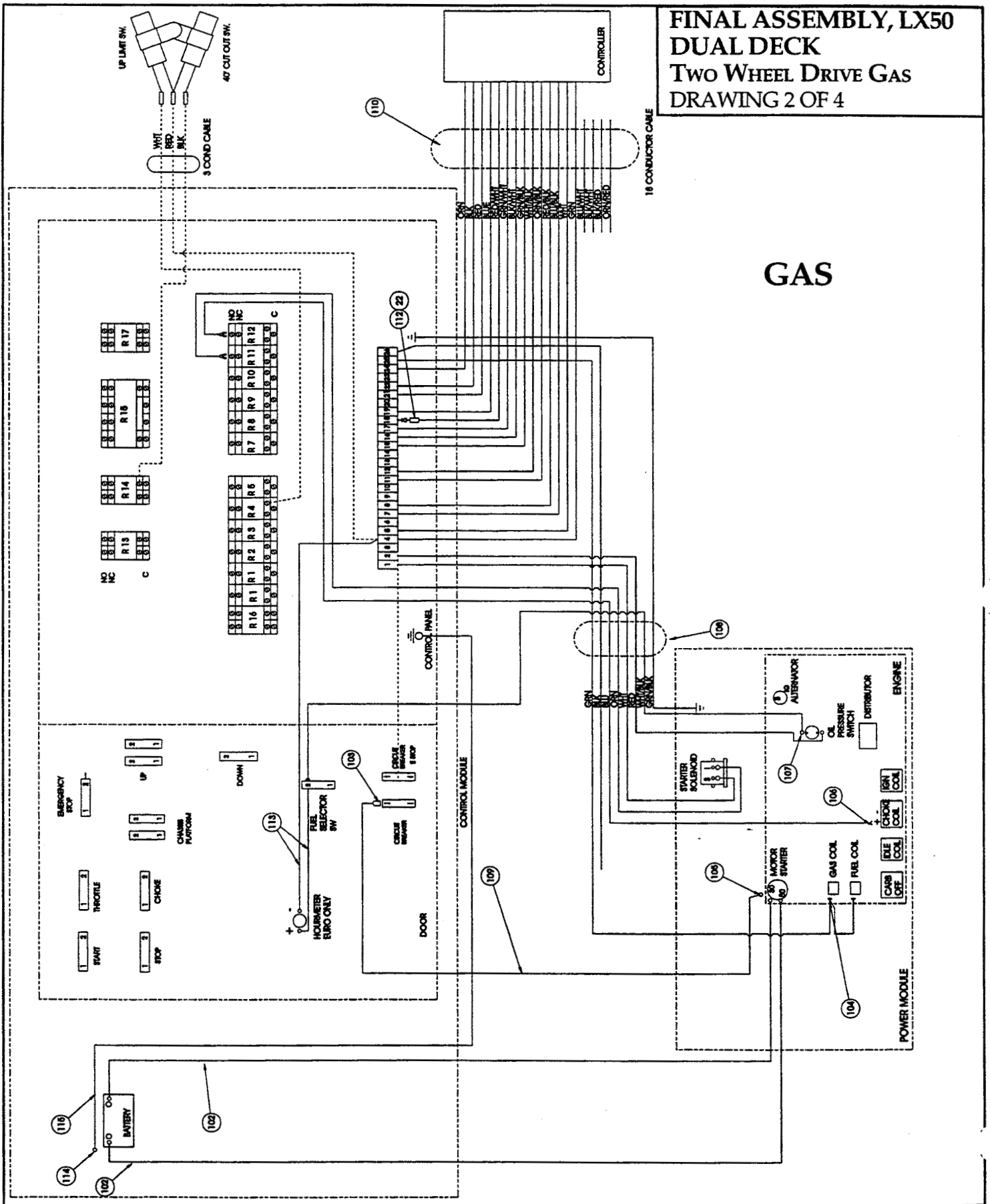

# Illustrated Parts Breakdown

**FINAL ASSEMBLY, LX50  
DUAL DECK  
Two Wheel Drive Diesel  
DRAWING 3 OF 4**

**UP TO SERIAL  
NUMBER 2218**

**DIESEL**

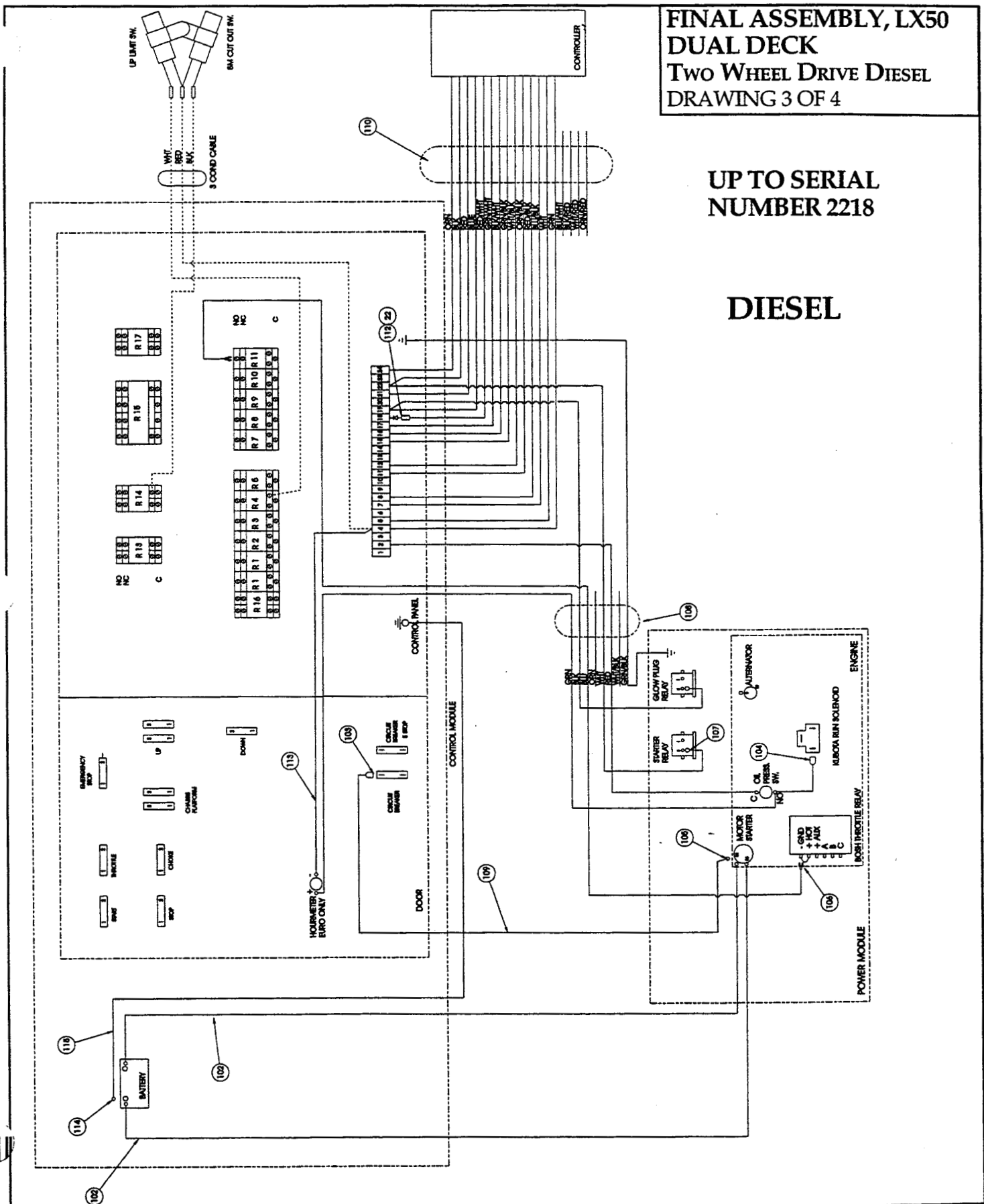

# Illustrated Parts Breakdown

**FINAL ASSEMBLY, LX50  
DUAL DECK  
Two Wheel Drive Diesel  
DRAWING 4 OF 4**

**SERIAL NUMBER 2219  
TO CURRENT**

**DIESEL**

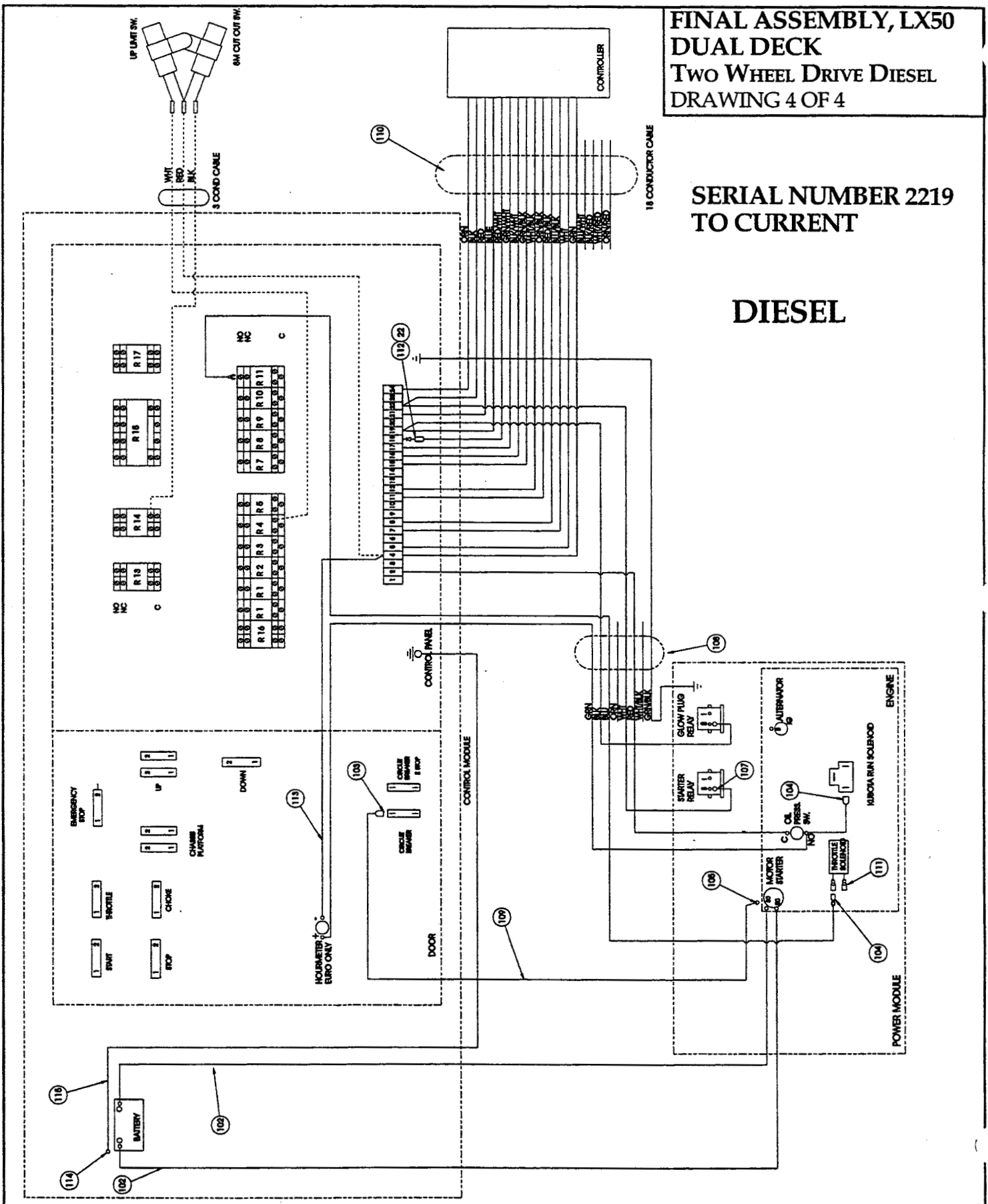

NOTES:

## Illustrated Parts Breakdown

FINAL ASSEMBLY, LX50 DUAL DECK  
FOUR WHEEL DRIVE GAS  
067410-000

ITEM	PART	DESCRIPTION	QTY.
1	067420-000	BASIC ASSY	1
2	067528-000	CONTROLLER ASSY	1
3	067536-002	CONTROL CABLE ASSY	1
4	067532-040	LABEL-KIT	1
5	067533-013	HOSE-KIT	1
6	030867-300	GUARDRAIL	1
7	067522-001	POWER MODULE	1
8	067521-006	CONTROL MODULE	1
9	067534-003	HYD SCHM.	REF
10	067535-018	ELEC. SCHM.	REF
11	067866-001	SLIDE-OUT DECK INSTL	1
12	067699-000	CHANNEL HOSE CLAMP	2
13	011248-004	LOCKNUT, 1/4-20 ESNA	8
14	014996-004	WASHER, 1/4 S.A.E.	8
15	067692-000	CLIP, CABLE RETAINER	8
16	020032-001	TEE, #4MJ-#4MJ-#4MJ	2
17	029945-013	LEVEL SENSOR	1
18	011252-006	SCRW, 1/4-20 X 3/4	4
19	012865-099	WIRE LOOM 3/4 DIA	8
20	065373-006	MAGNET	2
21	065373-005	SWITCH	2
22	067913-000	ALUM. SW. PAD	1
23	026551-005	RIVET 1/8 X 1/4 GRIP	8
24	029447-099	CABLE 3 COND. 16 GA.	10 FT
25	029620-002	CONN. BUTT 16-14 GA.	9
26	063497-001	MERCURY SWITCH	2
27	013919-013	CLAMP	2
28	067758-099	HOSE GUARD	14.7
30	067863-000	SWITCH MOUNT	1
*	013283-002	CABLE MOUNT	6
32	011923-007	FITTING ADA 12MP-4FP	1
33	011940-004	FITTING 90 4MP-4MJ	1
*	015963-099	STRAP MATL	11
*	015964-000	STRAP HEAD	9
*	020398-012	HOSE CLAMP	6
37	067950-001	OUTRIGGER OPTION	1
38	067866-002	SLIDE OUT DECK -REAR	1
102	062125-002	BATTERY CABLE ASSY	2
103	029616-003	TERMINAL, FEMALE PUSH	1
104	029616-002	TERMINAL, FEMALE PUSH	4
105	029601-019	TERMINAL, RING	1
106	029610-002	TERMINAL, FORK	5
107	029601-011	TERMINAL, RING	3
108	005469-099	WIRE, 9 CONDUCTOR	14'
109	029480-099	WIRE, 10GA STRD RED	14'
110	067536-001	CONTROL CABLE ASSY	REF
111	029496-099	WIRE, 2 CONDUCTOR	10'
112	029825-002	DIODE	1
113	029451-099	WIRE, 16 AWG WHITE	2
114	029601-039	CONN RING 5/16 10-12	2
115	029481-099	WIRE, 10 AWG BLK	FT 5.5

FINAL ASSEMBLY, LX50 DUAL DECK  
FOUR WHEEL DRIVE DIESEL  
067411-000

ITEM	PART	DESCRIPTION	QTY.
1	067420-000	BASIC ASSY	1
2	067528-000	CONTROLLER ASSY	1
3	067536-002	CONTROL CABLE ASSY	1
4	067532-041	LABEL-KIT	1
5	067533-013	HOSE-KIT	1
6	030867-300	GUARDRAIL	1
7	067522-002	POWER MODULE	1
8	067521-007	CONTROL MODULE	1
9	067534-003	HYD SCHM.	REF
10	067535-025	ELEC. SCHM.	REF
11	067866-001	SLIDE-OUT DECK INSTL	1
12	067699-000	HOSE CLAMP CHANNEL	2
13	011248-004	LOCKNUT 1/4-20 ESNA	8
14	014996-004	WASHER 1/4" SAE	8
15	067692-000	CLIP, CABLE RETAINER	8
16	020032-001	TEE, #4MJ-#4MJ-#4MJ	2
17	029945-013	LEVEL SENSOR	1
18	011252-006	SCRW, 1/4-20 X 3/4	4
19	012865-099	WIRE LOOM 3/4 DIA	8
20	065373-006	MAGNET	2
21	065373-005	SWITCH	2
22	067913-000	ALUM. SW. PAD	1
23	026551-005	RIVET 1/8 X 1/4 GRIP	8
24	029447-099	CABLE 3 COND. 16 GA.	10 FT
25	029620-002	CONN. BUTT 16-14 GA.	5
26	063497-001	MERCURY SWITCH	2
27	013919-013	CLAMP	2
28	067758-099	HOSE GUARD	14.7
30	067863-000	SWITCH MOUNT	1
*	013283-002	CABLE MOUNT	6
32	011923-007	FITTING ADA 12MP-4FP	1
33	011940-004	FITTING 90 4MP-4MJ	1
*	015963-099	STRAP MATL	11
*	015964-000	STRAP HEAD	9
*	020398-012	HOSE CLAMP	6
37	067950-001	OUTRIGGER OPTION	1
38	067866-002	SLIDE OUT DECK -REAR	1
102	062125-002	BATTERY CABLE ASSY	2
103	029616-003	TERMINAL, FEMALE PUSH	1
104	029616-002	TERMINAL, FEMALE PUSH	2
105	029601-019	TERMINAL, RING	1
106	029610-002	TERMINAL, FORK	4
107	029601-011	TERMINAL, RING	2
108	005469-099	WIRE, 9 CONDUCTOR	14'
109	029480-099	WIRE, 10GA STRD RED	14'
110	067536-001	CONTROL CABLE ASSY	REF
111	029496-099	WIRE, 2 CONDUCTOR	10'
112	029825-002	DIODE	1
113	029451-099	WIRE, 16 AWG WHITE	2
114	029601-039	CONN RING 5/16 10-12	2
115	029481-099	WIRE 10 AWG BLK	FT 5.5
116	029617-002	CONN, MALE PUSH 16-14GA. .25	2

\* Not Shown

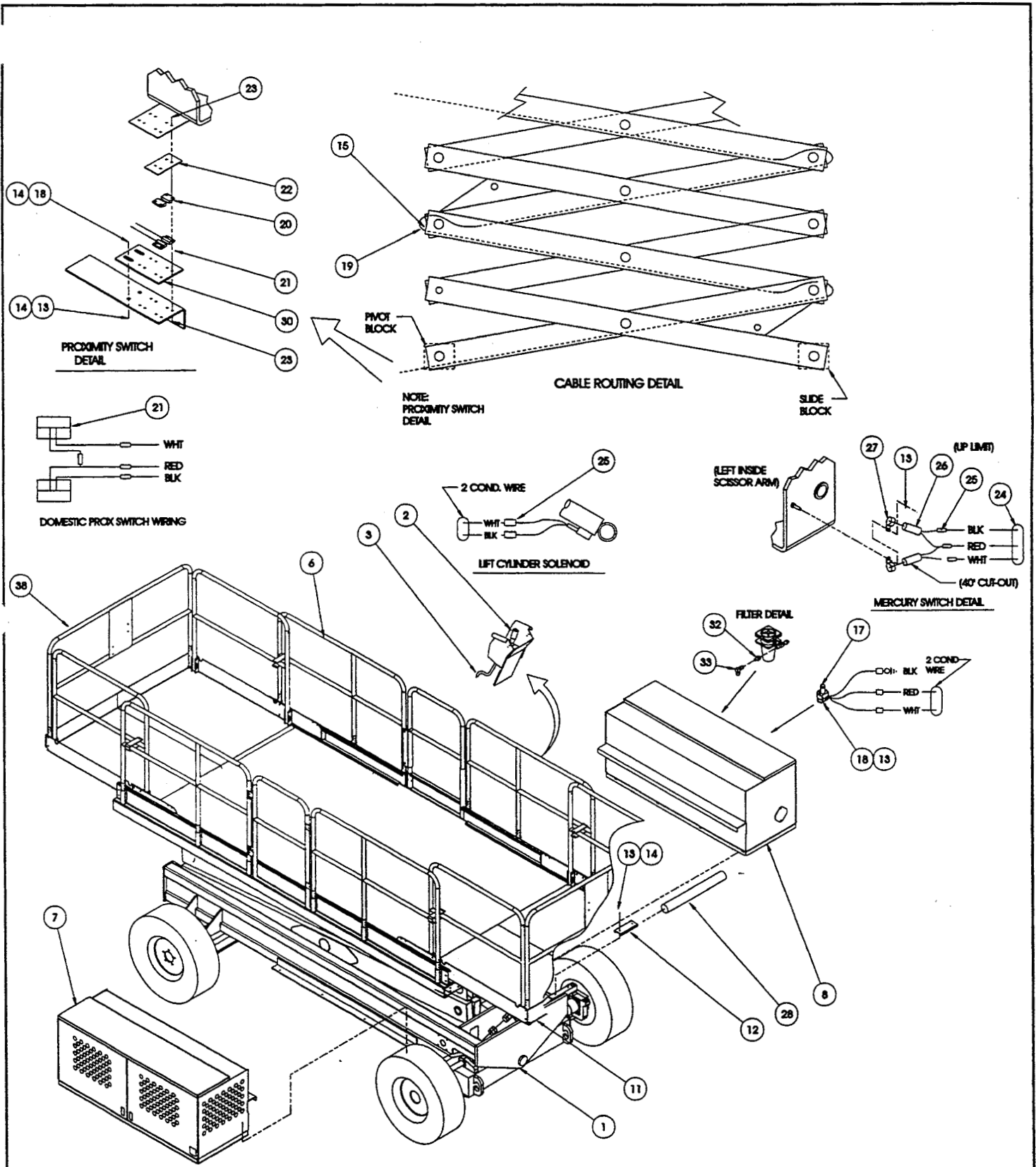

**FINAL ASSEMBLY, LX50 DUAL DECK  
FOUR WHEEL DRIVE GAS/DIESEL  
DRAWING 1 OF 4**

# Illustrated Parts Breakdown

**FINAL ASSEMBLY, LX50  
DUAL DECK  
FOUR WHEEL DRIVE GAS  
DRAWING 2 OF 4**

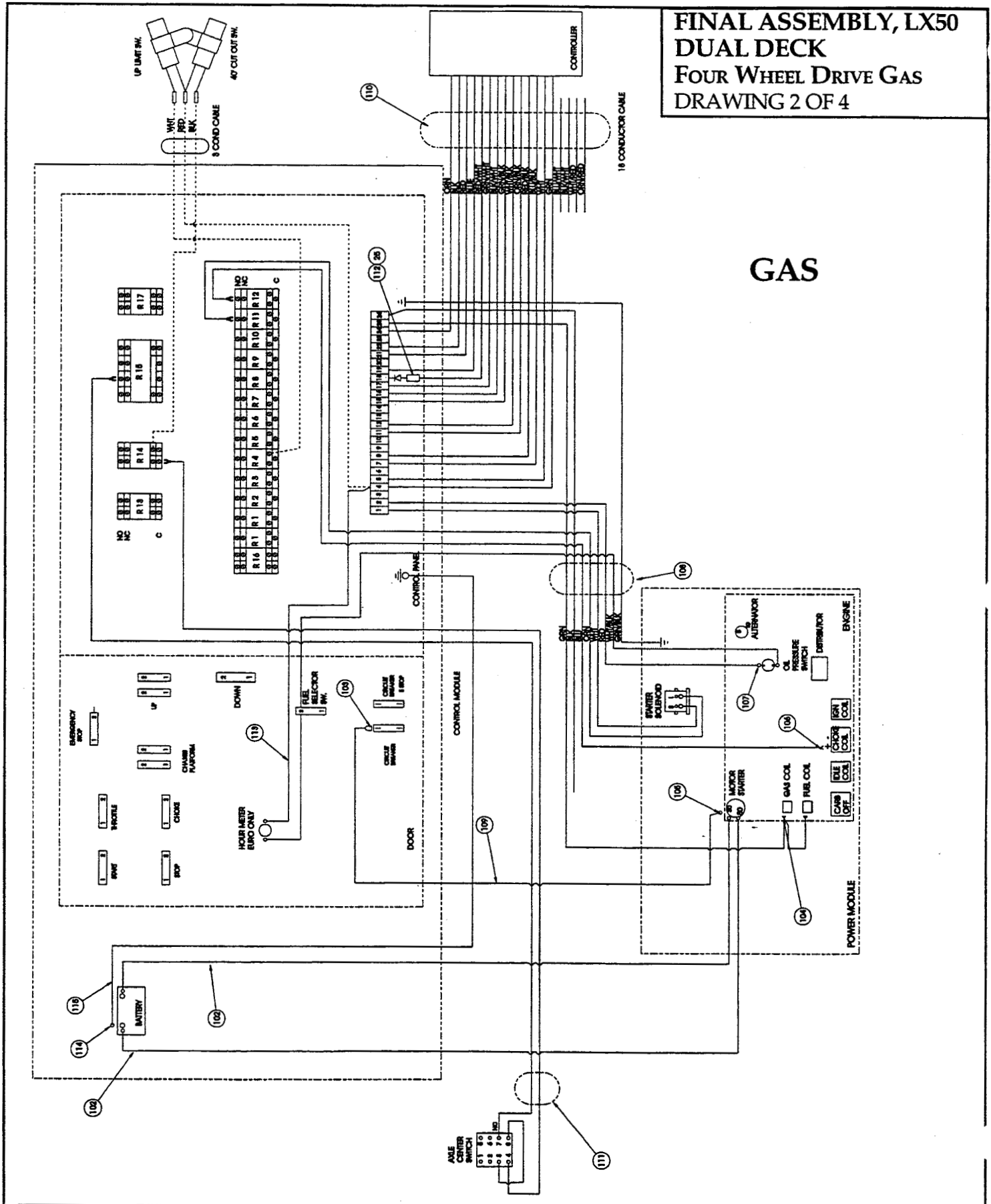

# Illustrated Parts Breakdown

**FINAL ASSEMBLY, LX50  
DUAL DECK  
FOUR WHEEL DRIVE DIESEL  
DRAWING 3 OF 4**

**UP TO SERIAL  
NUMBER 2219**

**DIESEL**

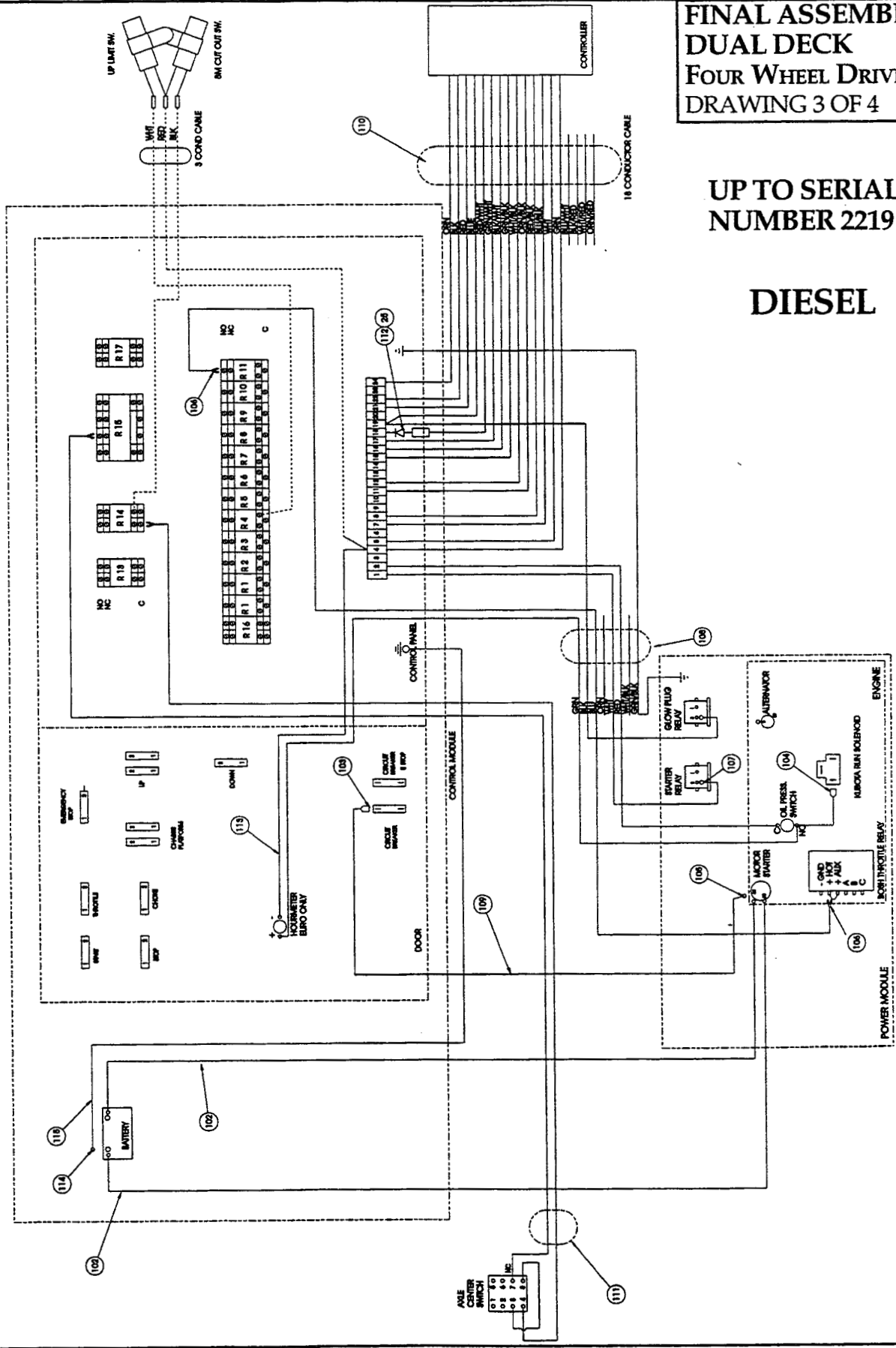



# Illustrated Parts Breakdown

**FINAL ASSEMBLY, LX50  
DUAL DECK  
FOUR WHEEL DRIVE DIESEL  
DRAWING 4 OF 4**

**SERIAL NUMBER  
2219 TO CURRENT**

**DIESEL**

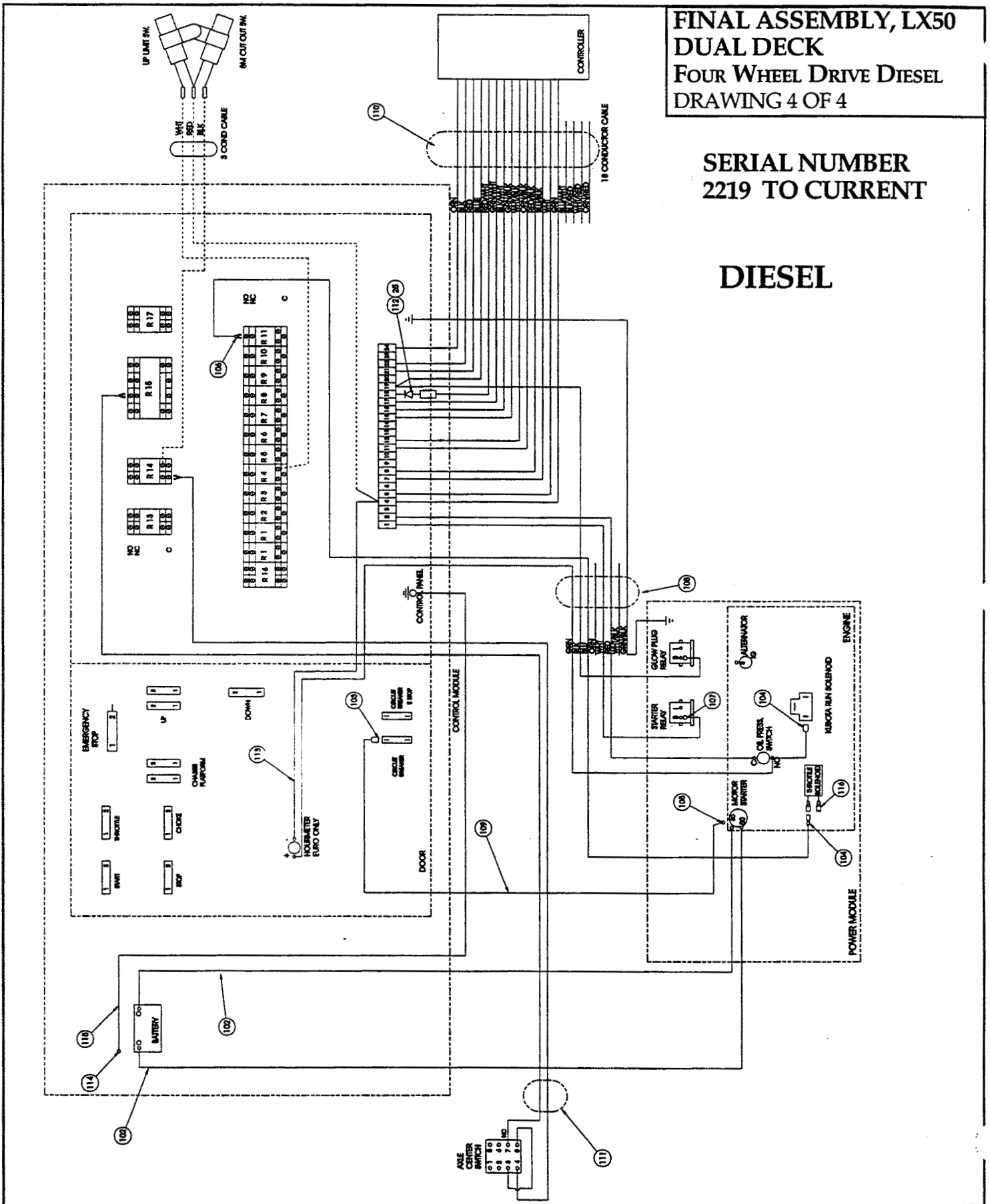

NOTES:

**BASIC ASSEMBLY, LX50**  
**TWO WHEEL DRIVE GAS/DIESEL**  
 067508-000

ITEM	PART	DESCRIPTION	QTY.
1	067518-001	CHASSIS ASSEMBLY	1
2	067517-000	SCISSOR LINKAGE	1
3	067780-001	PLATFORM WELDMENT	1
4	067879-000	MOTOR COVER	2
5	011253-008	SCR HHC 5/16 X 1	8
6	067962-000	LADDER WELDMENT	1
7	067738-000	SLIDE BLOCK	6
8	067852-000	PIN	4
9	067853-000	PIN	2
10	014996-005	WASHER 5/16 DIA	8
11	066189-000	SPACER 1/4	4
12	067853-001	PIN	2
13	066189-004	SPACER 1/8	8
15	011256-012	SCREW HHC 1/2-13 X 1 1/2	4
16	011296-028	SCREW SHC 1/2-13 X 3 1/2	8
17	014033-032	SCREW HHC 1/2-13 X 4 GR.8	8
20	011248-008	NUT 1/2-13 ESNA	16

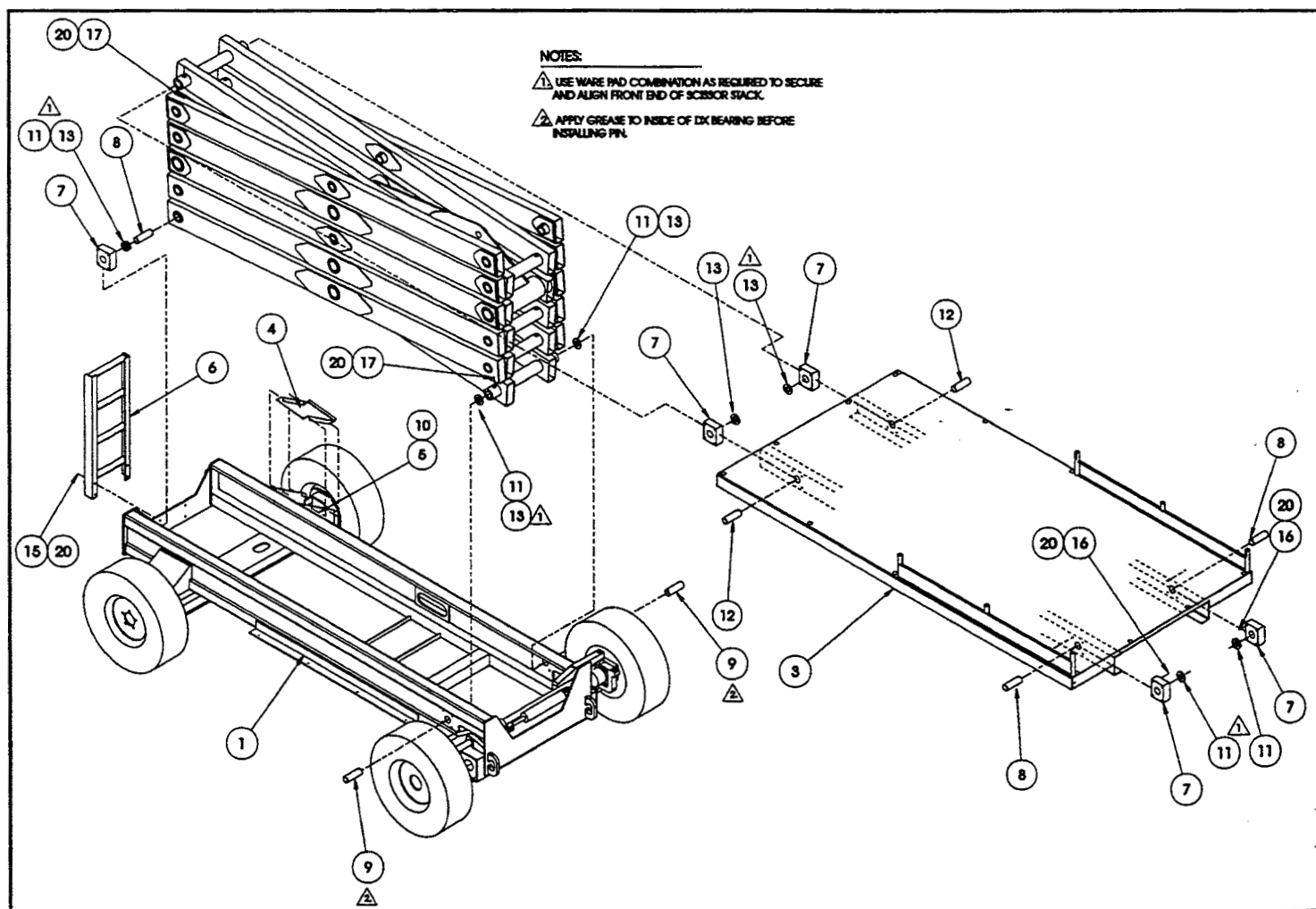

# Illustrated Parts Breakdown

**BASIC ASSEMBLY, LX50**  
**FOUR WHEEL DRIVE GAS/DIESEL**  
 U67509-000

ITEM	PART	DESCRIPTION	QTY.
1	067519-001	CHASSIS ASSEMBLY	1
2	067517-000	SCISSOR LINKAGE	1
3	067780-001	PLATFORM WELDMENT	1
4	067879-000	MOTOR COVER	2
5	011253-008	SCR HHC 5/16 X 1	8
6	067962-000	LADDER WELDMENT	1
7	067738-000	SLIDE BLOCK	6
8	067852-000	PIN	4
9	067853-000	PIN	2
10	014996-005	WASHER 5/16 DIA	8
11	066189-000	SPACER 1/4	2
12	067853-001	PIN	2
13	066189-004	SPACER 1/8	8
15	011256-012	SCREW 1/2-13 X 1 1/2	4
16	011296-028	SCREW SHC 1/2-13 X 3 1/2	8
17	014033-032	SCREW HHC 1/2-13 X 4	8
20	011248-008	NUT 1/2-13 ESNA	16

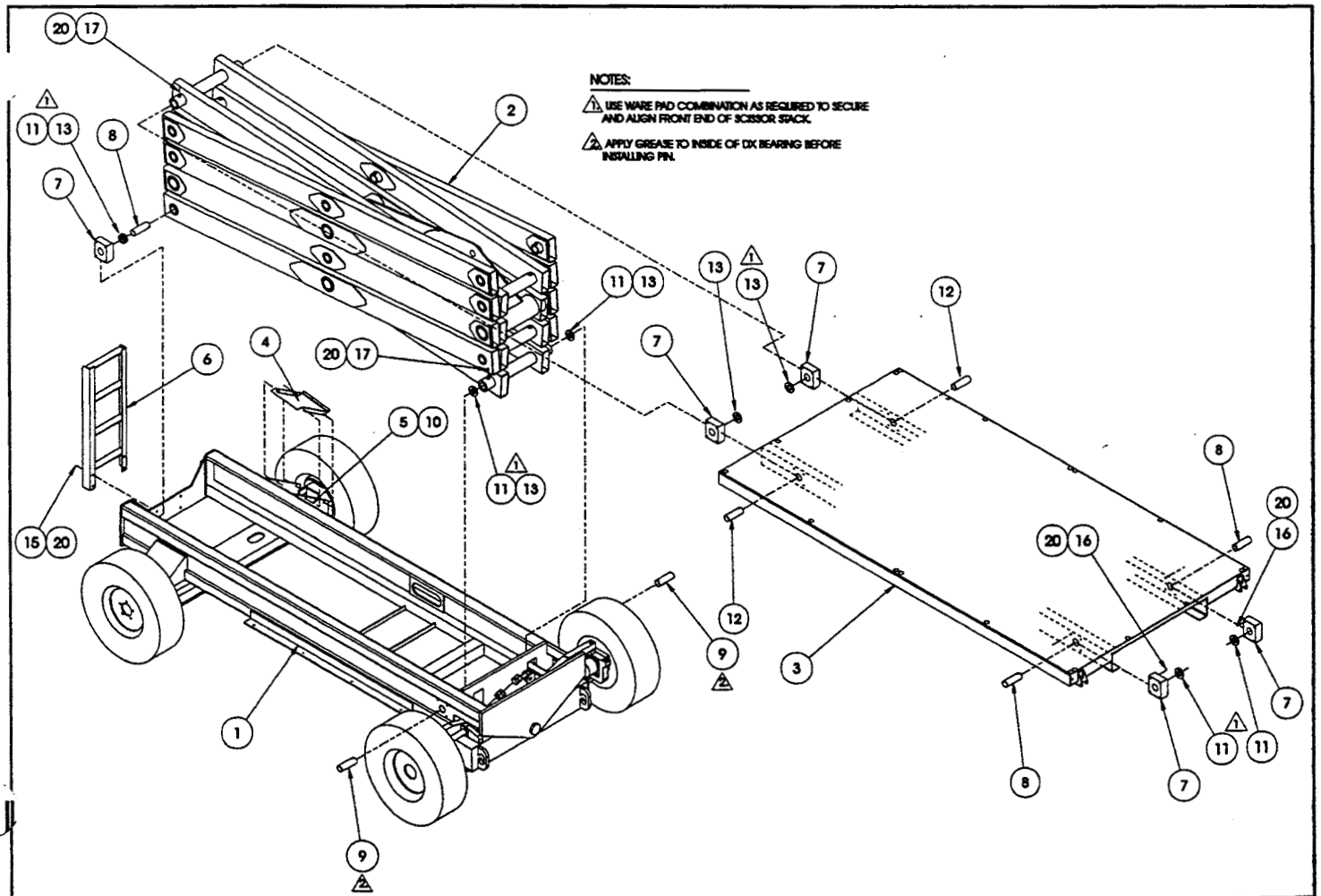

**BASIC ASSEMBLY, LX50 DUAL DECK**  
**TWO WHEEL DRIVE GAS/DIESEL**  
 067419-000

ITEM	PART	DESCRIPTION	QTY.
1	067518-001	CHASSIS ASSEMBLY	1
2	067424-000	SCISSOR LINKAGE	1
3	030841-101	PLATFORM WELDMENT	1
4	067879-000	MOTOR COVER	2
5	011253-008	SCR HHC 5/16 X 1	8
7	067738-000	SLIDE BLOCK	6
8	067852-000	PIN	4
9	067853-000	PIN	2
10	014996-005	WASHER 5/16 DIA	8
11	066189-000	SPACER 1/4	4
12	067853-001	PIN	2
13	066189-004	SPACER 1/8	8
16	011296-028	SCREW SHC 1/2-13 X 3 1/2	8
17	014033-032	SCREW HHC 1/2-13 X 4 GR.8	8
20	011248-008	NUT 1/2-13 ESNA	12

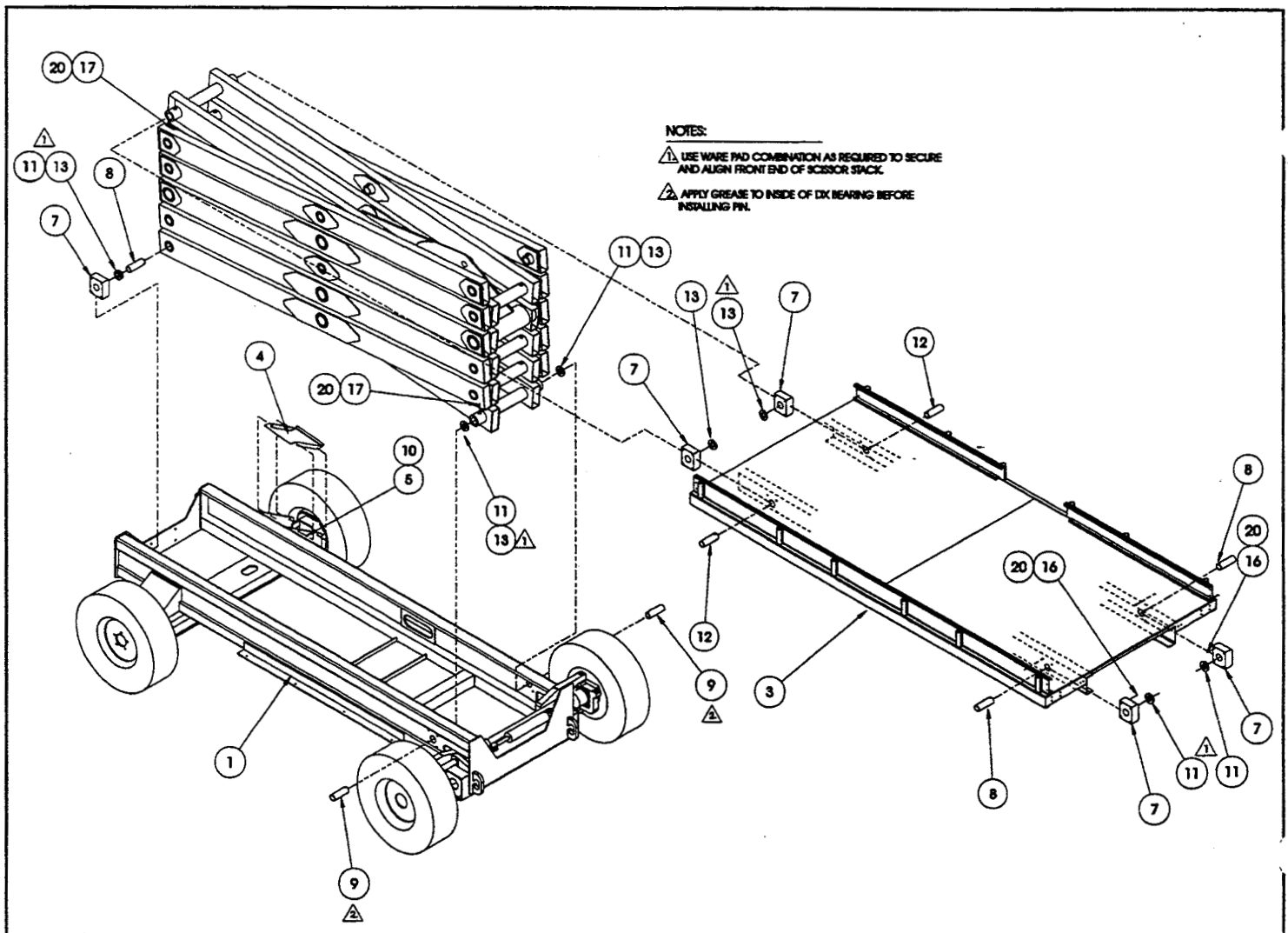

# Illustrated Parts Breakdown

## BASIC ASSEMBLY, LX50 DUAL DECK FOUR WHEEL DRIVE GAS/DIESEL J67420-000

ITEM	PART	DESCRIPTION	QTY.
1	067519-001	CHASSIS ASSEMBLY	1
2	067424-000	SCISSOR LINKAGE	1
3	030841-101	PLATFORM WELDMENT	1
4	067879.000	MOTOR COVER	2
5	011253-008	SCR HHC 5/16 X 1	8
7	067738-000	SLIDE BLOCK	6
8	067852-000	PIN	4
9	067853-000	PIN	2
10	014996-005	WASHER 5/16 DIA	8
11	066189-000	SPACER 1/4	2
12	067853-001	PIN	2
13	066189-004	SPACER 1/8	8
16	011296-028	SCREW SHC 1/2-13 X 3 1/2	8
17	014033-032	SCREW HHC 1/2-13 X 4	8
20	011248-008	NUT 1/2-13 ESNA	12

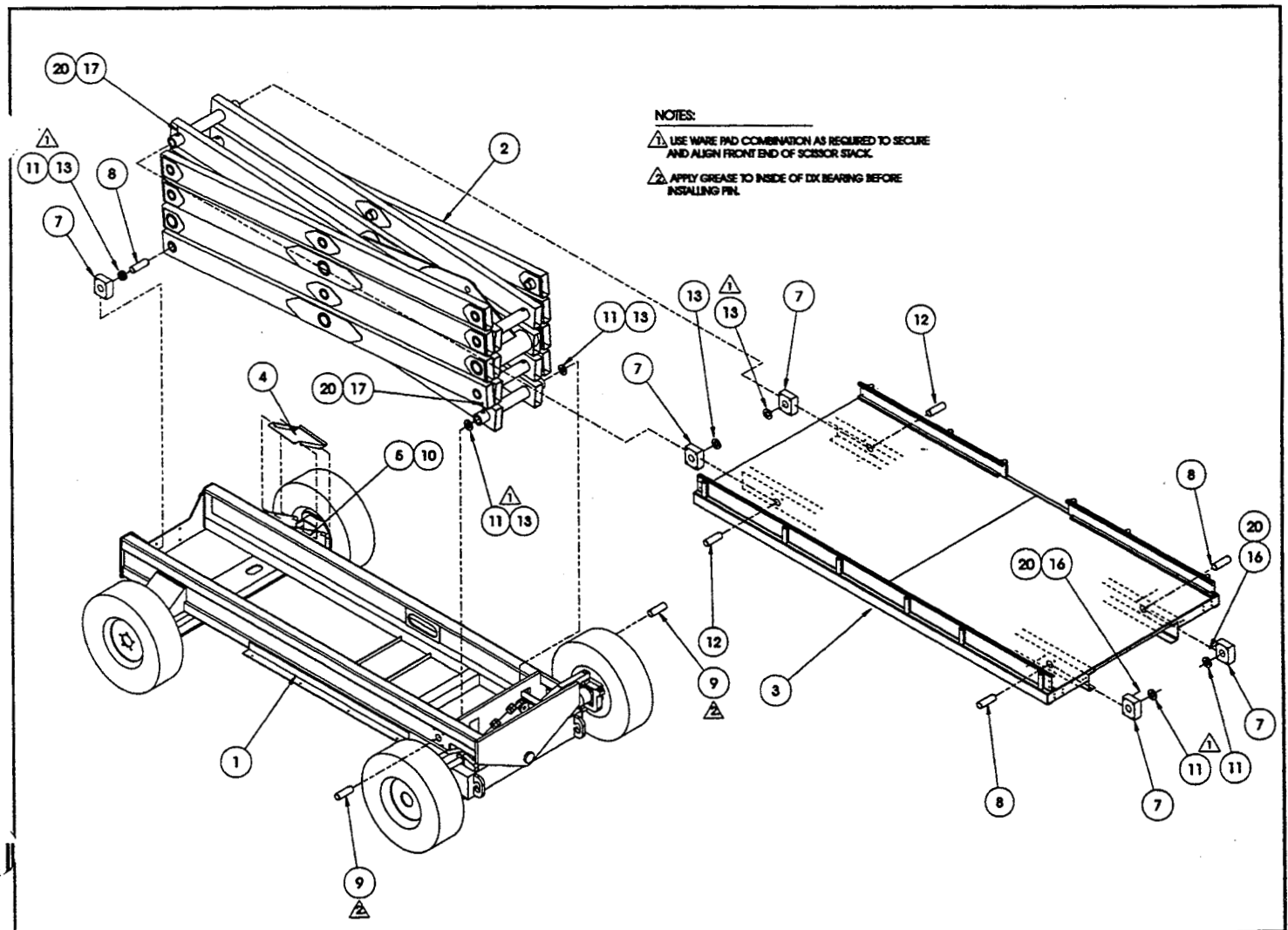

**CHASSIS ASSEMBLY, LX50**  
**TWO WHEEL DRIVE GAS/DIESEL**  
 067518-001

ITEM	PART	DESCRIPTION	QTY.
1	067715-000	CHASSIS WELDMENT (FIXED AXLE)	1
2	067743-000	TRUNNION (L.H.)	1
3	067742-000	TRUNNION (R.H.)	1
4	067739-000	STEERING LINK	1
5	067812-000	BUSHING, STEERING	2
6	067813-000	CONNECTING LINK	2
7	067746-000	TRUNNION PIN LOWER	2
8	067833-000	SPINDLE WELDMENT	2
9	067748-000	STEERING CLAMP	1
11	067816-000	PLATE WELDMENT	1
12	067613-000	HUB, 8 BOLT ON 8" B.C.	2
*	067613-010	GREASE SEAL	1
*	067613-011	INNER CUP	1
*	067613-012	OUTER CUP	1
*	067613-013	INNER CONE	1
*	067613-014	OUTER CONE	1
*	067613-015	DUST CAP	1
*	067613-016	STUD	1
13	067600-000	TORQUE HUB	2
*	067600-010	BEARING	2
*	067600-011	SHAFT SEAL	2
*	067600-012	STUD	10
*	067600-013	O-RING	2
14	067603-000	BRAKE	2
*	067603-010	BRAKE SEAL KIT	1
15	067601-001	HYDRAULIC MOTOR	2
*	067601-010	HYD MTR SEAL KIT	1
16	067633-000	STEERING CYLINDER	1
*	067633-010	STEERING CYL SEAL KIT	1
17	011252-020	SCREW HHC 1/4-20 X 2 1/2	4
19	011248-004	NUT 1/4-20 HEX ESNA	4
20	067606-020	BEARING, SCISSOR PIVOT	2
21	062642-020	BUSHING 16DU16	4
22	062649-020	BEARING, STEERING ROD	2
23	067606-010	BEARING, 16DX16	6
24	067665-002	TIRE & WHEEL ASSY FRONT RHD	1
*	067609-001	WHEEL, 16.5 X 8.25, 8 BOLT	1
*	067610-000	TIRE, 10-16.5 NHS 8 PLY	1
*	012282-001	VALVE STEM	1
25	067665-003	TIRE & WHEEL ASSY FRONT LHD	1
*	067609-001	WHEEL, 16.5 X 8.25, 8 BOLT	1
*	067610-000	TIRE, 10-16.5 NHS 8 PLY	1
*	012282-001	VALVE STEM	1

ITEM	PART	DESCRIPTION	QTY.
26	011254-020	SCREW HHC 3/8-16 X 2 1/2	6
27	011248-006	NUT 3/8-16 HEX ESNA	6
28	011258-012	SCREW HHC 3/4-10 X 1 1/2	4
29	011238-008	WASHER 1/2 SPLIT LOCK	33
30	011256-012	SCREW HHC 1/2-13 X 1 1/2	16
31	011257-028	SCREW HHC 5/8-11 X 3 1/2	2
32	011248-008	NUT 1/2-13 HEX ESNA	10
33	011256-024	SCREW HHC 1/2-13 X 3	8
34	011848-050	PIN CLEVIS 1 X 2 3/4	1
35	067746-001	PIN STEERING LINK	2
36	011256-020	SCREW HHC 1/2-13 X 2 1/2	2
37	013315-011	RETAINING "E" RING	2
38	062889-012	PIN, HAIR COTTER .177 X 3 1/2	2
39	011935-006	FITTING 10 MB - 10 MJ 45°	2
40	011469-005	LUG NUT 9/16-18	10
41	011934-011	FITTING, 10 MB - 10 MJ 90°	4
42	011934-001	FITTING, 4 MB - 4 MJ 90°	3
43	011934-003	FITTING, 6 MB - 4 MJ 90°	2
44	012030-010	SCRW SOC HD CAP 1/2-13 X 1-1/4	8
45	011848-051	PIN CLEVIS 1 DIA. X 2	1
46	063978-000	HAND PUMP	1
47	011240-006	WASHER 3/8 STD	2
48	012877-008	VALVE, BI DIRECTIONAL RELIEF	2
49	012030-032	SCRW SOC HD CAP 1/2-13 X 4	4
50	067746-002	PIN TRUNNION UPPER	2
51	067666-002	TIRE/WHEEL ASSY REAR RHD	1
*	067605-000	WHEEL, 16.5 X 8.25, 5 BOLT	1
*	067610-000	TIRE, 10-16.5 NHS 8 PLY	1
*	012282-001	VALVE STEM	1
52	067666-003	TIRE/WHEEL ASSY REAR LHD	1
*	067605-000	WHEEL, 16.5 X 8.25, 5 BOLT	1
*	067610-000	TIRE, 10-16.5 NHS 8 PLY	1
*	012282-001	VALVE STEM	1
53	011941-001	FITTING 4MB-4MJ STR	1
54	011238-012	WASHER SPLIT LOCK 3/4	4
55	064279-000	THRUST WASHER	2
56	011248-010	NUT 5/8-11 HEX ESNA	2
57	067805-099	GROMMET MATL	FT 7
58	024501-003	SHEET 1/8 RUBBER 3 X 48	1
59	020495-009	NUT HEX JAM 9/16-18UNF	1
60	067961-000	VALVE POPET N.C.	1
61	011937-003	FITTING 6FJX-6MJ 90	1

\* Not Shown

# Illustrated Parts Breakdown

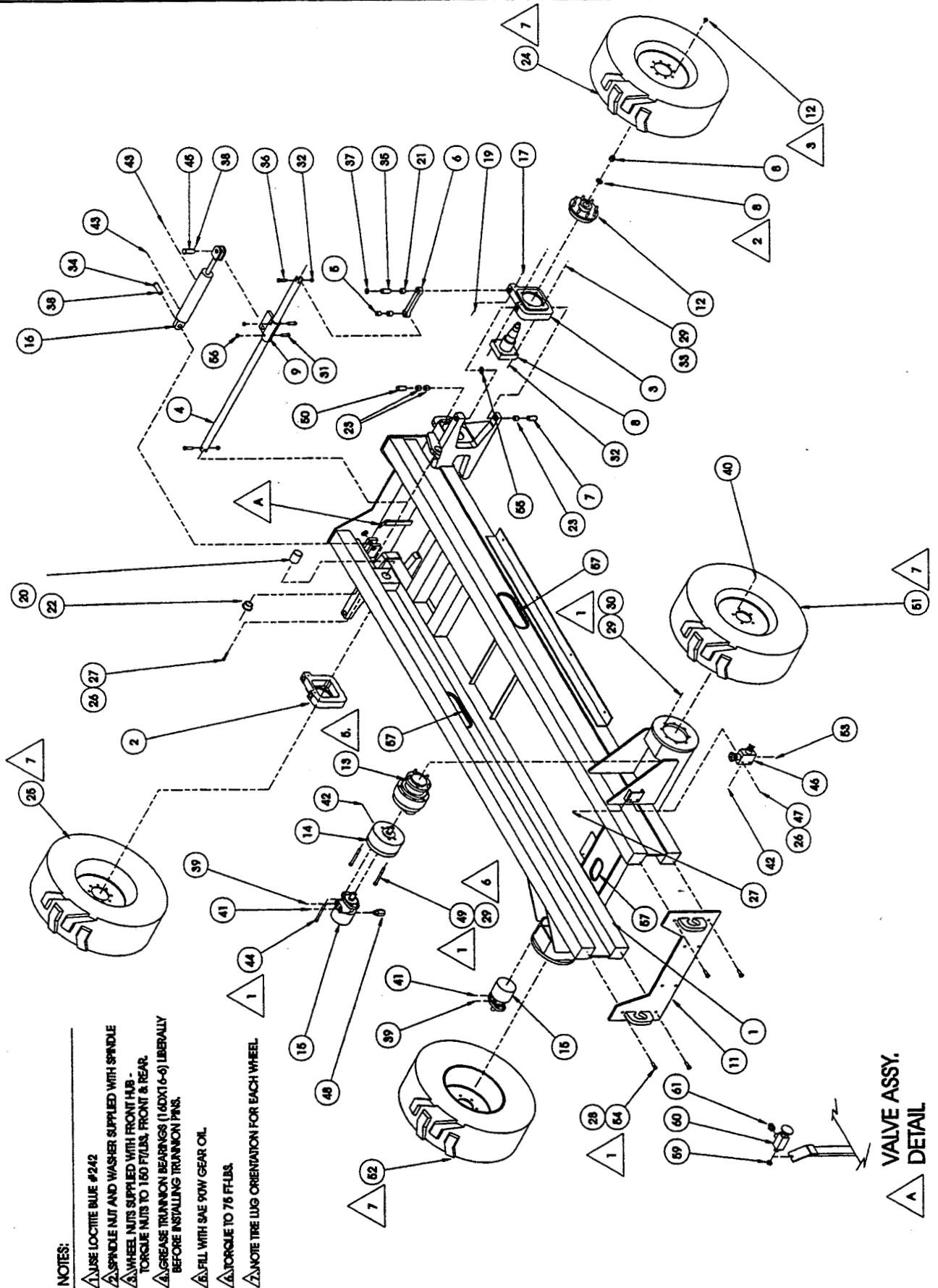

**NOTES:**

- ▲ USE LOCTITE BLUE #242
- ▲ SPINDLE NUT AND WASHER SUPPLIED WITH SPINDLE
- ▲ WHEEL NUTS SUPPLIED WITH FRONT HUB - TORQUE NUTS TO 160 FT.LBS. FRONT & REAR.
- ▲ GREASE TRANNON BEARINGS (160X176-6) LIBERALLY BEFORE INSTALLING TRANNON PINS.
- ▲ FILL WITH SAE 90W GEAR OIL.
- ▲ TORQUE TO 76 FT.LBS.
- ▲ NOTE THE LUG ORIENTATION FOR EACH WHEEL.

VALVE ASSY.  
DETAIL





**CHASSIS ASSEMBLY, LX50**  
**FOUR WHEEL DRIVE GAS/DIESEL**  
 067519-001

ITEM	PART	DESCRIPTION	QTY.
1	067729-000	CHASSIS WELDMENT	1
2	067700-000	AXLE WELDMENT	1
3	067743-000	TRUNNION (L.H.)	1
4	067742-000	TRUNNION (R.H.)	1
5	067739-000	STEERING LINK	1
6	067812-000	BUSHING, STEERING	2
7	067813-000	CONNECTING LINK	2
8	067746-000	TRUNNION PIN	2
9	067814-000	PIVOT SHAFT, FRONT AXLE	1
10	067748-000	STEERING CLAMP	1
11	011238-012	LOCKWASHER SPLIT 3/4	4
12	067816-000	PLATE WELDMENT	1
13	067607-002	HYDRAULIC MOTOR (FRONT)	2
14	067600-000	TORQUE HUB	2
*	067600-010	BEARING	2
*	067600-011	SHAFT SEAL	2
*	067600-012	STUD	10
*	067600-013	O-RING	2
15	067603-000	BRAKE	2
*	067603-010	BRAKE SEAL KIT	1
16	067601-001	HYDRAULIC MOTOR	2
*	067601-010	HYD MTR SEAL KIT	1
17	067633-000	STEERING CYLINDER	1
*	067633-010	STEERING CYL SEAL KIT	1
18	067634-000	AXLE PIVOT CYLINDER	1
*	067634-010	AXLE PIVOT CYLINDER SEAL KIT	1
19	067637-000	PIVOT BUSHING	2
20	027931-057	BEARING, PIVOT CYL.	2
21	067606-020	BEARING, SCISSOR PIVOT	2
22	064298-004	BEARING, AXLE PIVOT	2
23	062649-020	BEARING, STEERING ROD	2
24	067606-010	BEARING 16DX16	6
25	067666-002	TIRE & WHEEL - RH	1
*	067605-000	WHEEL, 16.5 X 8.25, 5 BOLT	1
*	067610-000	TIRE, 10-16.5 NHS 8 PLY	1
*	012282-001	VALVE STEM	1
26	067666-003	TIRE & WHEEL - LH	1
*	067605-000	WHEEL, 16.5 X 8.25, 5 BOLT	1
*	067610-000	TIRE, 10-16.5 NHS 8 PLY	1
*	012282-001	VALVE STEM	1
27	067664-002	TIRE & WHEEL - RH 4WD FRONT	1
*	067609-000	WHEEL, 16.5 X 8.25, 6 BOLT	1
*	067610-000	TIRE, 10-16.5 NHS 8 PLY	1
*	012282-001	VALVE STEM	1
28	067664-003	TIRE & WHEEL - LH 4WD FRONT	1
29	011252-020	SCREW, HHC 1/4-20UNC X 2-1/2	6
30	011248-004	NUT, HEX 1/4-20 ESNA	6
31	062642-020	BEARING, 16 DU 12	4
32	067746-001	STEERING LINK PIN	2
33	011254-020	SCREW, HHC 3/8-16UNC X 2-1/2	6
34	011248-006	NUT, HEX 3/8-16UNC ESNA	6

ITEM	PART	DESCRIPTION	QTY.
35	062889-012	PIN, HAIR COTTER .177 X 3-1/2	2
36	011848-050	PIN, CLEVIS 1 X 2-3/4	1
37	013315-011	RETAINING "E" RING	2
38	011256-020	SCREW, HHC 1/2-13UNC X 2-1/2	2
39	011248-008	NUT, HEX 1/2-13UNC ESNA	19
40	011256-028	SCREW, HHC 1/2-13UNC X 3-1/2	2
41	011256-012	SCREW, HHC 1/2-13UNC X 1-1/2	17
42	011238-008	LOCKWASHER, SPLIT 1/2	37
43	011249-016	LOCKNUT, HEX 1-14UNF ESNA	4
44	011297-016	WASHER, BELL 1"	4
45	064370-001	CYLINDER PIN 1 X 5-1/4	2
46	011258-012	SCREW, HHC 3/4-10UNC X 1-1/2	4
47	012030-032	SCREW, SOC HD 1/2-13UNC X 4	8
48	011469-005	LUG NUT, 9/16-18 90°	10
49	012004-004	FITTING, PLUG SAE#4	4
50	015961-004	FITTING, TEE 4MB - 4MJ - 4MJ	2
51	011934-001	FITTING, 90° 4MB - 4MJ	7
52	011937-001	FITTING, 90° 4FJX - 4MJ	2
53	015961-010	FITTING, TEE 10MB - 10MJ-10MJ	1
54	010150-005	FITTING, BULKHD. 8MJ - 8MJ	4
55	011941-014	FITTING, 12MB - 8MJ	2
56	011935-006	FITTING, 45° 10MB - 10MJ	2
57	011934-011	FITTING, 90° 10MB - 10MJ	1
58	011934-003	FITTING, 90° 6MB - 4MJ	2
59	012030-010	SCREW SOC HD 1/2-13 X 1-1/4	8
60	067878-000	AXLE COVER 4WD	1
61	067674-008	FITTING 45° 12MB - 8MJ	4
62	064296-003	LIMIT SWITCH	1
63	064294-004	CLAMP LEVER	1
64	012002-010	FITTING 10MJ - 10MJ 90°	4
65	064297-001	CHECK VALVE	2
66	011848-051	CLEVIS PIN 1" DIA. X 2"	1
67	063978-000	PUMP HAND (BRAKE)	1
68	011240-006	WASHER 3/8 STD	2
69	012877-008	VALVE BI-DIRECTIONAL RELIEF	2
71	011709-018	SCREW MACH RD HD 10-24 X 2-1/4	4
72	011248-003	NUT HEX ESNA 10-24	4
73	067746-002	TRUNNION PIN UPPER	2
74	011935-003	FITTING 6MB - 6MJ 45°	1
75	011941-005	FITTING 6MB - 6MJ STR	1
76	011252-004	SCREW HHC 1/4-20 X 1/2	2
77	011240-004	WASHER 1/4 FLAT STD	2
78	064279-000	THRUST WASHER	2
79	067805-099	GROMMET MATL	FT 7
80	024501-003	SHEET 1/8 RUBBER 3 X 48	1
81	013336-003	FITTING LUBE	4
82	020495-009	NUT HEX JAM 9/16-18UNF	1
83	067961-000	VALVE POPET N.C.	1
84	011937-003	FITTING 6FJX-6MJ 90	1
85	067865-000	WHEEL HUB	2
86	014122-001	WHEEL BOLT	12
87	012030-024	SCREW SOC HD 1/2-13 X 3	8

\* Not Shown

# Illustrated Parts Breakdown

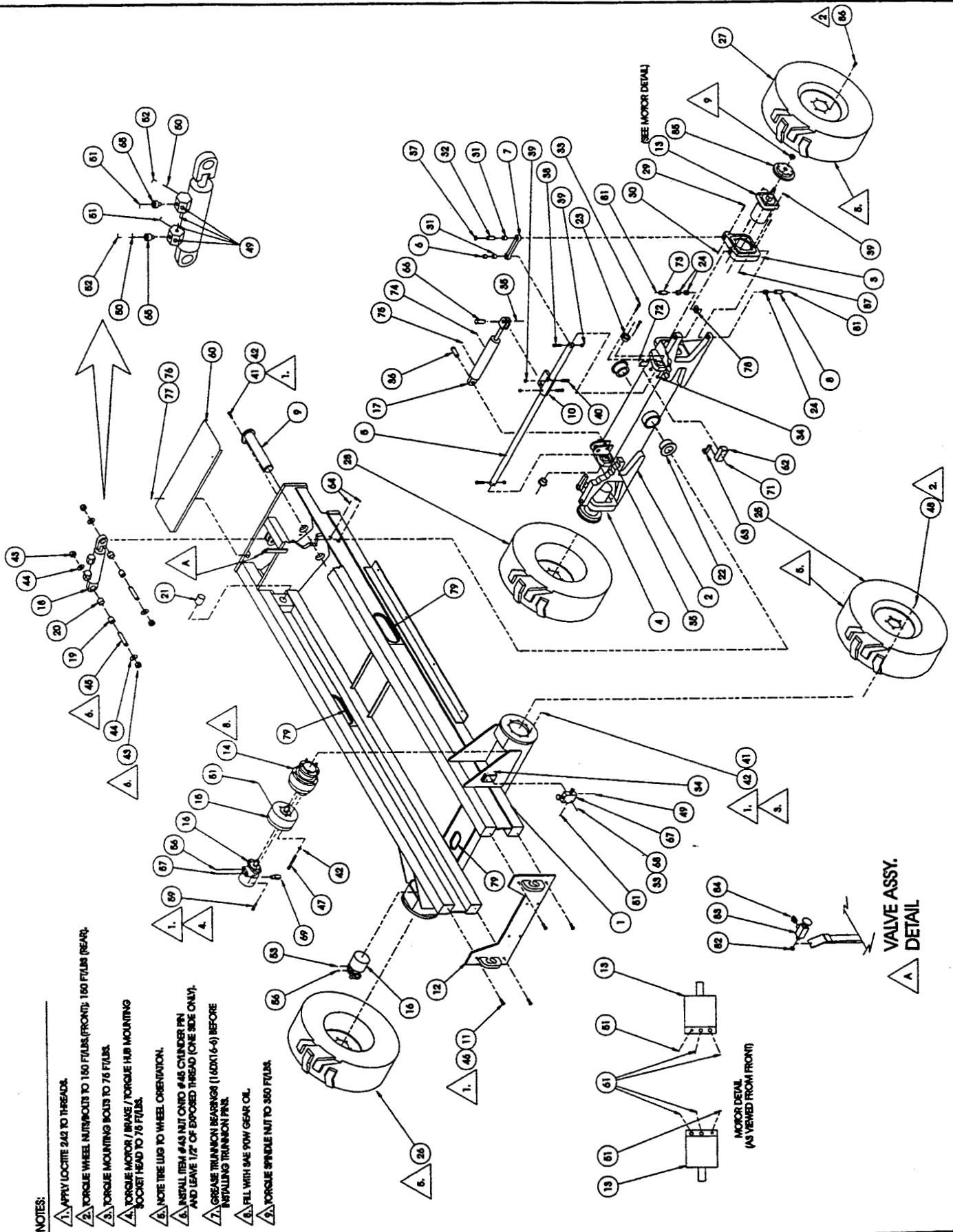

**NOTES:**

- ▲ 1. APPLY LOCITE 242 TO THREADS.
- ▲ 2. TORQUE WHEEL NUTS/BOITS TO 150 FT/LBS.(FRONT); 160 FT/LBS (REAR).
- ▲ 3. TORQUE MOUNTING BOLTS TO 75 FT/LBS.
- ▲ 4. TORQUE MOTOR / BRAKE / TORQUE HUB MOUNTING SOCKET HEAD TO 75 FT/LBS.
- ▲ 5. NOTE THE LUG TO WHEEL ORIENTATION.
- ▲ 6. INSTALL ITEM #45 NUT ONTO #46 CHAMFER PIN AND LEAVE 1/2" OF EXPOSED THREAD (ONE SIDE ONLY).
- ▲ 7. GREASE TRUNNION BEARINGS (1.6DXT1-6-4) BEFORE INSTALLING TRUNNION PIN.
- ▲ 8. FILL WITH SAE 90W GEAR OIL.
- ▲ 9. TORQUE SPINDLE NUT TO 350 FT/LBS.

▲ VALVE ASSY. DETAIL

MOTOR DETAIL (AS VIEWED FROM FRONT)

## SCISSOR LINKAGE ASSEMBLY

LX50

067517-000

ITEM	PART	DESCRIPTION	QTY.
1	067968-001	ARM WELDMENT	1
2	067969-000	ARM WELDMENT	1
3	067970-000	ARM WELDMENT	1
4	067971-000	ARM WELDMENT	2
5	067972-001	ARM WELDMENT	1
6	067973-000	ARM WELDMENT	2
7	067974-000	ARN WELDMENT	1
8	067975-000	ARM WELDMENT	2
9	067557-000	ARM WELDMENT	1
10	067606-020	BEARING, 2" I.D. X 1 1/2" LG.	44
11	067606-030	BEARING, 3" I.D. X 1 1/2" LG.	8
12	067583-000	PIN WELDMENT	20
13	067580-000	PIN WELDMENT	4
14	067585-000	PIN WELDMENT	2
15	067586-000	PIN, CYLINDER	4
16	067635-005	LIFT CYLINDER	1
*	067635-015	SEAL KIT	1
17	014033-048	SCREW 1/2-13 UNC X 6 GR. 8	4
18	014033-032	SCREW HHC 1/2-13 UNC X 4 GR. 8	12
19	011248-008	HEX LOCK NUT 1/2-13 UNC	26
20	067591-000	SUPPORT WELDMENT	2
21	013336-001	GREASE FITTING	26
22	011941-005	STRAIGHT ADAPTER #6	2
23	060291-000	DOWN VALVE	2
24	003570-001	RETAINING PIN ASSLY	1
25	067556-000	ARM WELDMENT	1
26	067976-001	ARM WELDMENT	1
27	015919-006	ORIFICE PLATE	2
28	005133-000	SPRING	2
29	011786-017	MACHINERY BUSHING, 2" ID X 14 GA.	2
30	11757-028	COTTER PIN 3/8 DIA X 3-1/2	2
31	014693-005	FITTING 10FJ-6MJ	2
32	067981-000	FITTING	2
33	067635-004	LIFT CYLINDER	1
*	067635-014	SEAL KIT	1
34	011256-036	SCREW HHC 1/2-13UNC X 4 1/2	10
35	011248-004	NUT HEX ESNA 1/4-20UNC	2
36	011252-036	SCREW HEX 1/4-20UNC X 4 1/2	2
37	067979-000	SCISSOR BRACE CONNECTOR WELDMENT	1

# Illustrated Parts Breakdown

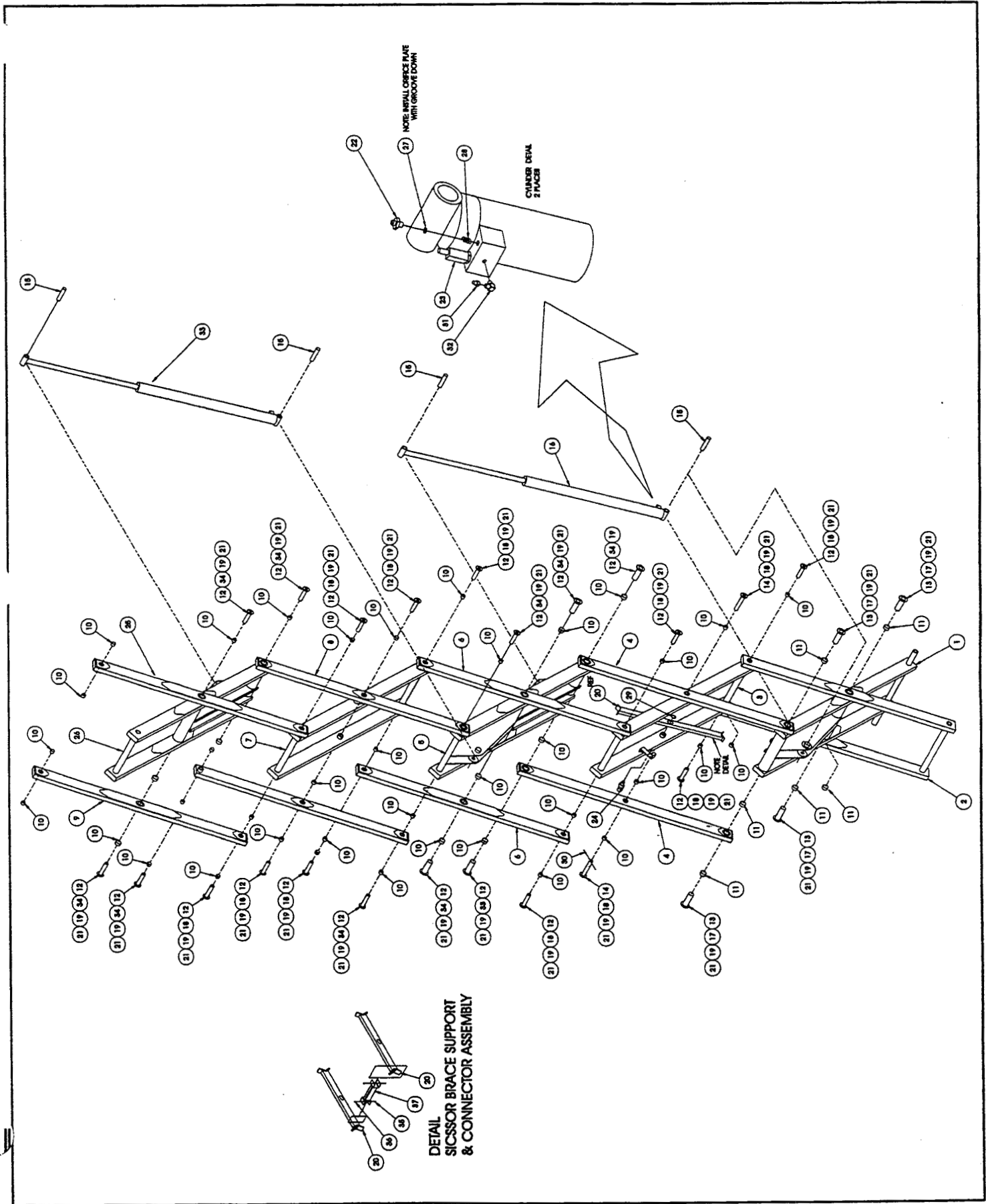

## SCISSOR LINKAGE ASSEMBLY

LX50, DUAL DECK

067424-000

ITEM	PART	DESCRIPTION	QTY.
1	067968-001	ARM WELDMENT	1
2	067969-001	ARM WELDMENT	1
3	067970-000	ARM WELDMENT	1
4	067971-001	ARM WELDMENT	2
5	067972-001	ARM WELDMENT	1
6	067973-000	ARM WELDMENT	2
7	067974-000	ARN WELDMENT	1
8	067975-000	ARM WELDMENT	2
9	067557-000	ARM WELDMENT	1
10	067606-020	BEARING, 2" I.D. X 1 1/2" LG.	44
11	067606-030	BEARING, 3" I.D. X 1 1/2" LG.	8
12	067583-000	PIN WELDMENT	20
13	067580-000	PIN WELDMENT	4
14	067585-000	PIN WELDMENT	2
15	067586-000	PIN, CYLINDER	4
16	067635-005	LIFT CYLINDER	1
*	067635-015	SEAL KIT	1
17	014033-048	SCREW 1/2-13 UNC X 6 GR. 8	4
18	014033-032	SCREW HHC 1/2-13 UNC X 4 GR. 8	12
19	011248-008	HEX LOCK NUT 1/2-13 UNC	26
20	067591-000	SUPPORT WELDMENT	2
21	013336-001	GREASE FITTING	26
22	011941-005	STRAIGHT ADAPTER #6	2
23	060291-000	DOWN VALVE	2
24	003570-001	RETAINING PIN ASSLY	1
25	067556-000	ARM WELDMENT	1
26	067976-001	ARM WELDMENT	1
27	015919-006	ORIFICE PLATE	2
28	005133-000	SPRING	2
29	011786-017	MACHINERY BUSHING, 2" ID X 14 GA.	2
30	011757-028	COTTER PIN 3/8 DIA X 3-1/2	2
31	014693-005	FITTING 10FJ-6MJ	2
32	067981-000	FITTING	2
33	067635-004	LIFT CYLINDER	1
*	067635-014	SEAL KIT	1
34	011256-036	SCREW HHC 1/2-13UNC X 4 1/2	10
35	011248-004	NUT HEX ESNA 1/4-20UNC	2
36	011252-036	SCREW HEX 1/4-20UNC X 4 1/2	2
37	067979-000	SCISSOR BRACE CONNECTOR WELDMENT	1

# Illustrated Parts Breakdown

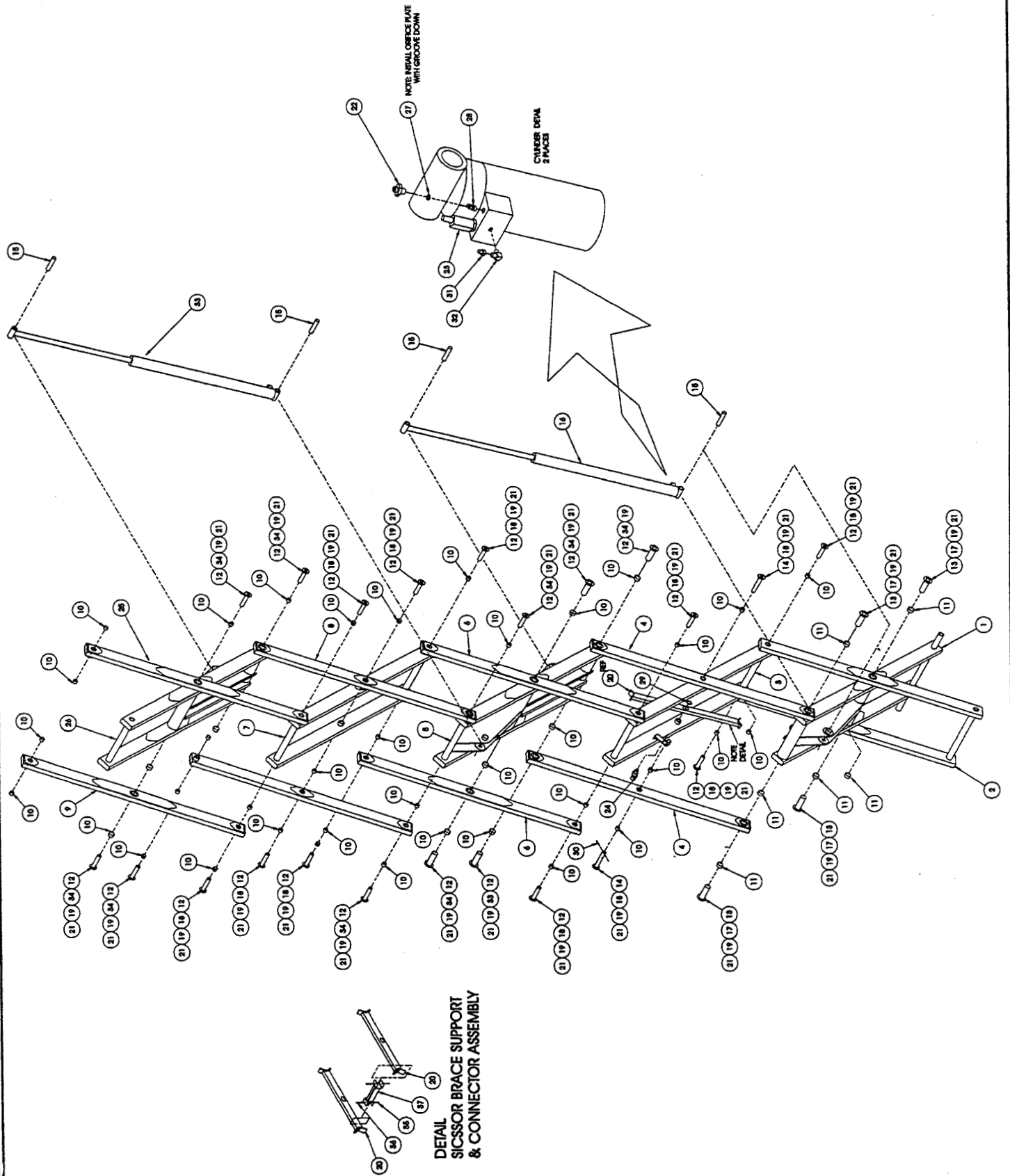

## CONTROL MODULE ASSEMBLY, LX 50 Two Wheel Drive Gas 067521-000

ITEM	PART	DESCRIPTION	QTY.
1	067810-000	CONTROL MODULE WELDMENT	1
2	067527-000	CONTROL BOX ASSY, D/F	1
3	067631-000	FUEL TANK, GASOLINE	1
4	063929-001	GAS CAP	1
6	064039-000	MOUNTING TAB, FUEL TANK	3
7	067629-000	LATCH, FLUSH LIFT & TURN	2
8	005299-000	LATCH, TOGGLE	2
10	063982-002	FUEL LEVEL GAGE	1
11	011240-004	WASHER 1/4 FLAT	2
13	012739-099	HOSE, 1/4 I.D.	11 FT
14	010178-003	FITTING, BARBED 1/4 X 4 MP	1
15	020541-001	HOSE CLAMP	2
16	011254-008	SCRW HHC GR5 3/8-16UNC X 1	13
17	011708-004	SCRW MACH RD HD 8-32UNC X 1/2	4
18	011248-002	LOCK NUT, ESMA 8-32UNC	4
19	064040-000	ANGLE, BATTERY HOLD DOWN	1
20	062299-002	BATTERY, 12 VDC GROUP-27C	1
22	012039-000	ROD, BATTERY HOLD DOWN	2
23	011920-002	PLUG 4MP	1
25	067808-000	HINGE, 1 1/2 X 23 7/8	2
26	067809-000	HINGE, 1 1/2 X 65	1
27	067799-002	MODULE COVER / CONTROL	1
28	067800-000	MODULE DOOR, R.H.	1
29	067801-000	MODULE DOOR, L.H.	1
30	026554-002	POP RIVET, 1/4 DIA (.251-.375 GRIP)	46
31	011248-006	NUT, 3/8-16 ESNA	14
32	011252-006	SCREW, HHC 1/4-20 X 3/4	2
33	011248-004	NUT, 1/4-20 ESNA	4

ITEM	PART	DESCRIPTION	QTY.
34	025427-002	HANDLE	1
35	067854-000	ANGLE, RESERVOIR MOUNT	1
36	067856-000	WELDMENT, STIFFENER	1
37	011254-006	SCREW HHC 3/8-16 X 3/4	3
38	062125-016	CABLE, BATTERY X 16	1
39	062125-002	CABLE, BATTERY X 69	1
40	014435-001	TERMINAL, BATTERY	2
41	010154-000	COVER, BATTERY TERMINAL	2
42	011237-006	WASHER, 3/8 STAR	1
48	011248-005	NUT, HEX 5/16-18 ESNA	2
49	067892-000	BRACKET, VALVE BLOCK	1
50	067524-000	VALVE BLOCK ASSY. (2 W.D.)	1
51	011254-004	SCRW HHC GR5 3/8-16UNC X 1/2	4
52	063650-012	GAS SPRING	1
53	067902-000	BRACKET, GAS SPRING	1
54	015936-004	SCR, SHOULDER 3/8 DIA. X 1/2	2
55	067648-008	END FITTING, GAS SPRING	2
56	011253-008	SCR HHC 5/16-18 X 1	2
102	029610-002	TERMINAL #6 FORK	12
103	029616-002	TERMINAL 16 GA FEMALE PUSH ON	18
104	029457-099	WIRE 16 GA - GREEN	4'
105	029451-099	WIRE 16 GA - WHITE	3'
106	029450-099	WIRE 16 GA - BLUE	3'
107	029452-099	WIRE 16 GA - BLACK	3'
109	029454-099	WIRE 16 GA - RED	3'
110	029453-099	WIRE 16 GA - ORANGE	3'
111	005491-099	WIRE 16 GA - GREEN/BLACK	3'
112	029477-099	WIRE 16 GA - ORANGE/BLACK	3'

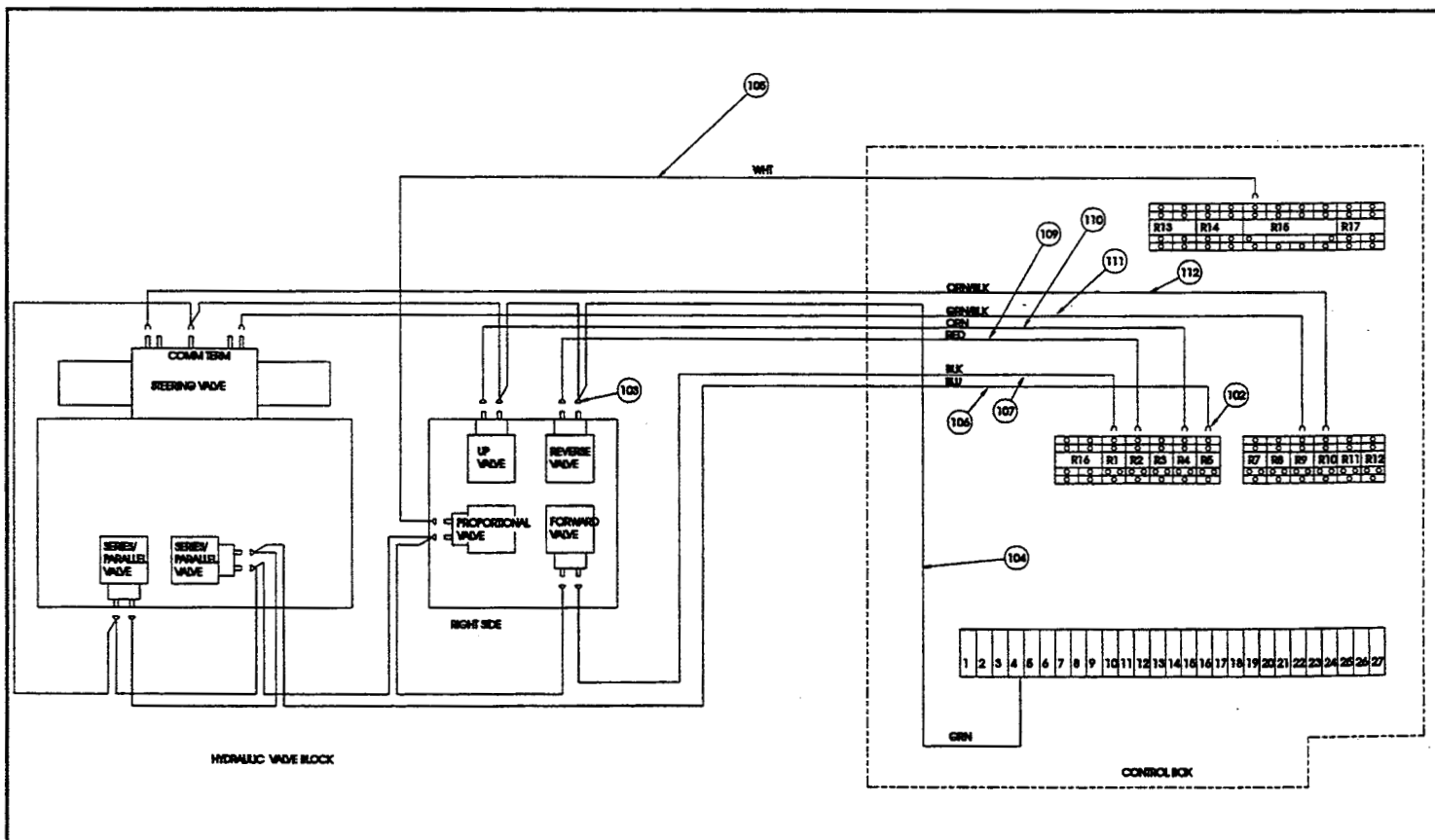

# Illustrated Parts Breakdown

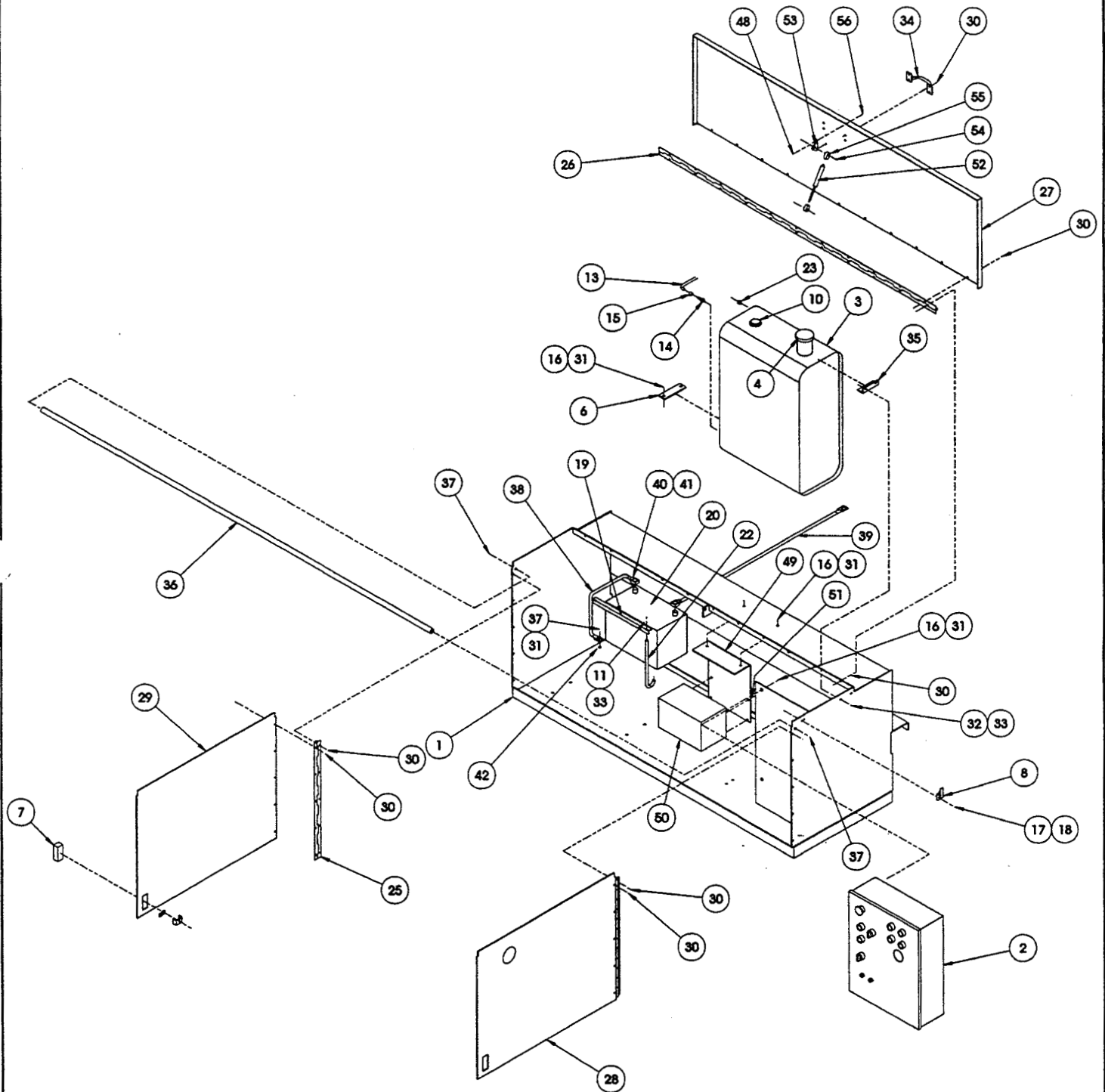



# Illustrated Parts Breakdown

## CONTROL MODULE ASSEMBLY, LX50 Two Wheel Drive Diesel 067521-001

ITEM	PART	DESCRIPTION	QTY.
1	067810-000	CONTROL MODULE WELDMENT	1
2	067527-001	CONTROL BOX ASSY, DIESEL	1
3	067631-000	FUEL TANK, GASOLINE	1
4	063929-001	GAS CAP	1
6	064039-000	MOUNTING TAB, FUEL TANK	3
7	067629-000	LATCH, FLUSH LIFT & TURN	2
8	005299-000	LATCH, TOGGLE	2
10	063982-002	FUEL LEVEL GAGE	1
11	011240-004	WASHER 1/4 FLAT	2
13	012739-099	HOSE, 1/4 I.D.	11 FT
14	010178-003	FITTING, BARBED 1/4 X 4MP	1
15	020541-001	HOSE CLAMP	4
16	011254-008	SCRW HHC GR5 3/8-16UNC X 1	10
17	011708-004	SCRW MACH RD HD 8-32UNC X 1/2	6
18	011248-002	LOCK NUT, ESMA 8-32UNC	6
19	064040-000	ANGLE, BATTERY HOLD DOWN	1
20	062299-002	BATTERY, 12 VDC GROUP-27C	1
21	012736-099	HOSE 3/16 ID	11 FT
22	012039-000	ROD, BATTERY HOLD DOWN	2
23	003495-001	FITTING 90°2FP-2MP	1
24	010178-001	FITTING BARBED 3/16 X 2MP	1
25	067808-000	HINGE, 1 1/2 X 23 7/8	2
26	067809-000	HINGE, 1 1/2 X 65	1
27	067799-002	MODULE COVER / CONTROL	1
28	067800-000	MODULE DOOR, R.H.	1
29	067801-000	MODULE DOOR, L.H.	1
30	026554-002	POP RIVET, 1/4 DIA (.251-.375 GRIP)	46
31	011248-006	NUT, 3/8-16 ESNA	11
32	011252-006	SCREW, HHC 1/4-20 X 3/4	2

ITEM	PART	DESCRIPTION	QTY.
33	011248-004	NUT, 1/4-20 ESNA	2
34	025427-002	HANDLE	1
35	067854-000	ANGLE, RESERVOIR MOUNT	1
36	067856-000	WELDMENT, STIFFENER	1
37	011254-006	SCREW HHC 3/8-16 X 3/4	3
38	062125-016	CABLE, BATTERY X 16	1
39	062125-002	CABLE, BATTERY X 69	1
40	014435-001	TERMINAL, BATTERY	2
41	010154-000	COVER, BATTERY TERMINAL	2
42	011237-006	WASHER, STAR INTERNAL 3/8	1
43	003556-001	FITTING ADAPTER 2FP-4MP	1
48	011248-005	NUT, HEX 5/16-18 ESNA	2
49	067892-000	BRACKET, VALVE BLOCK	1
50	067524-000	VALVE BLOCK ASSY. (2 W.D.)	1
51	011254-004	SCR HHC GR5 3/8-16UNC X 1/2	4
52	063650-012	GAS SPRING	1
53	067902-000	BRACKET, GAS SPRING	1
54	015936-004	SCR, SHOULDER 3/8 DIA X 1/2	2
55	067648-008	END FITTING, GAS SPRING	2
56	011253-008	SCR, HHC 5/16-18 X 1	2
102	029610-002	TERMINAL #6 FORK	12
103	029616-002	TERMINAL 16 GA FEMALE PUSH ON	18
104	029457-099	WIRE 16 GA - GREEN	4'
105	029451-099	WIRE 16 GA - WHITE	3'
106	029450-099	WIRE 16 GA - BLUE	3'
107	029452-099	WIRE 16 GA - BLACK	3'
109	029454-099	WIRE 16 GA - RED	3'
110	029453-099	WIRE 16 GA - ORANGE	3'
111	005491-099	WIRE 16 GA - GREEN/BLACK	3'
112	029477-099	WIRE 16 GA - ORANGE/BLACK	3'

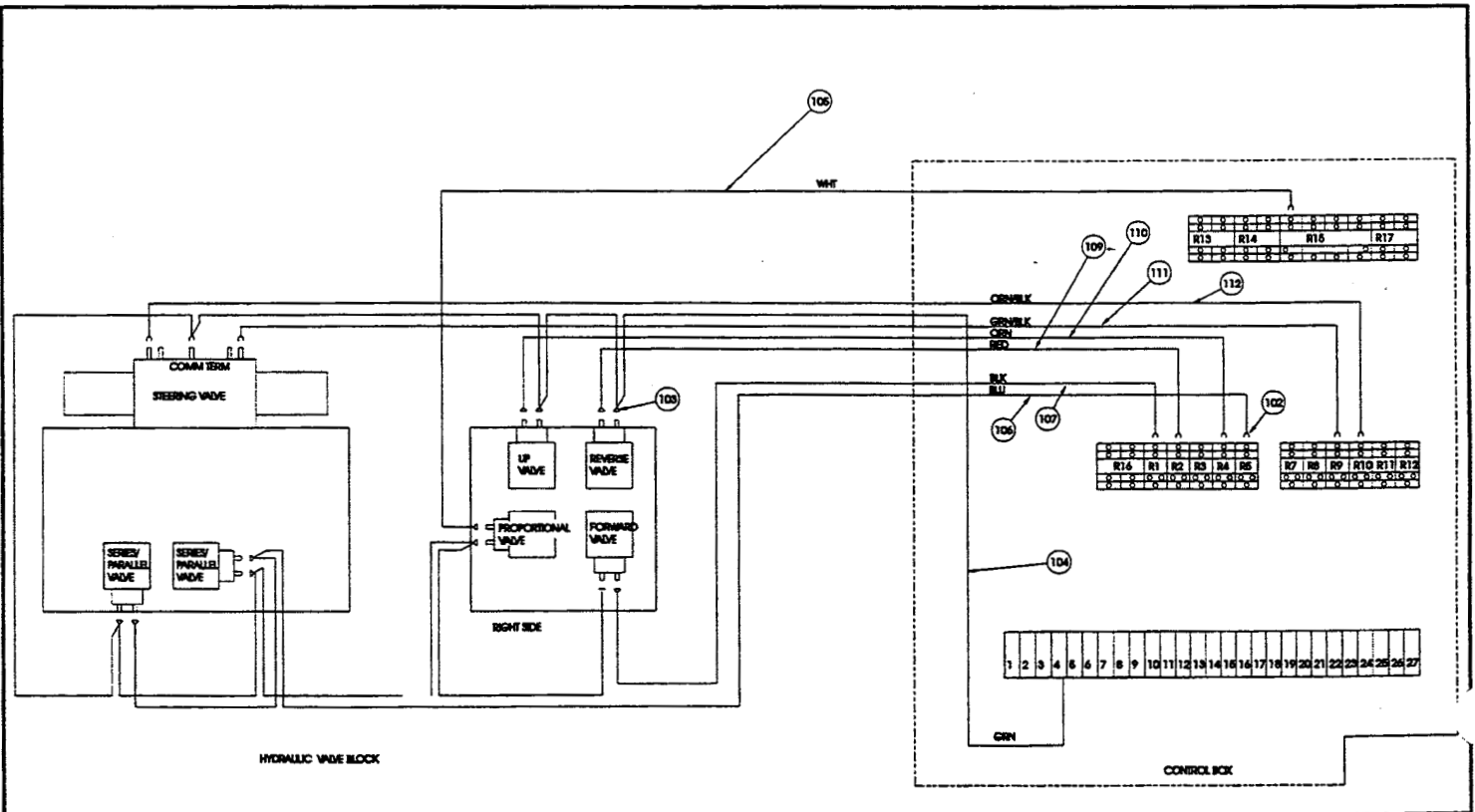

# Illustrated Parts Breakdown

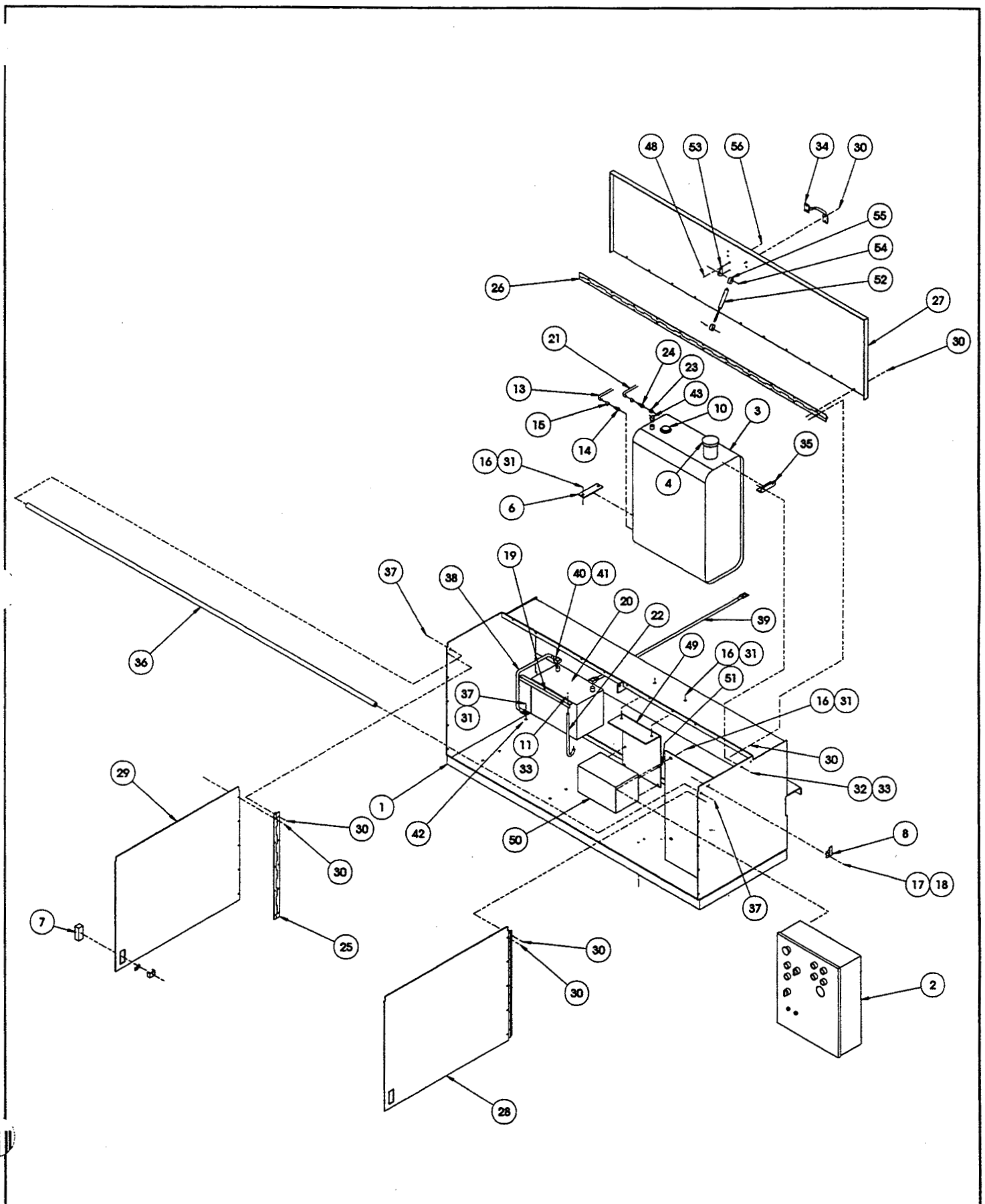

## CONTROL MODULE ASSEMBLY, LX50 FOUR WHEEL DRIVE GAS 067521-002

ITEM	PART	DESCRIPTION	QTY.
1	067810-000	CONTROL MODULE WELDMENT	1
2	067527-000	CONTROL BOX ASSY, D/F	1
3	067631-000	FUEL TANK, GASOLINE	1
4	063929-001	GAS CAP	1
6	064039-000	MOUNTING TAB, FUEL TANK	3
7	067629-000	LATCH, FLUSH LIFT & TURN	2
8	005299-000	LATCH, TOGGLE	2
10	063982-002	FUEL LEVEL GAGE	1
11	011240-004	WASHER 1/4 FLAT	2
13	012739-099	HOSE, 1/4 I.D.	11 FT
14	010178-003	FITTING, BARBED 1/4	1
15	020541-001	HOSE CLAMP	1
16	011254-008	SCRW HHC GR5 3/8-16UNC X 1	13
17	011708-004	SCRW MACH RD HD 8-32UNC X 1/2	4
18	011248-002	LOCK NUT, ESMA 8-32UNC	4
19	064040-000	ANGLE, BATTERY HOLD DOWN	1
20	062299-002	BATTERY, 12 VDC GROUP-27C	1
22	012039-000	ROD, BATTERY HOLD DOWN	2
23	011920-002	FITTING PLUG 4 MP	1
25	067808-000	HINGE, 1 1/2 X 23 7/8	2
26	067809-000	HINGE, 1 1/2 X 65	1
27	067799-002	MODULE COVER / CONTROL	1
28	067800-000	MODULE DOOR, R.H.	1
29	067801-000	MODULE DOOR, L.H.	1
30	026554-002	POP RIVET, 1/4 DIA (.251-.375 GRIP)	46
31	011248-006	NUT, 3/8-16 ESNA	14
32	011252-006	SCREW, HHC 1/4-20 X 3/4	2
33	011248-004	NUT, 1/4-20 ESNA	4
34	025427-002	HANDLE	1

ITEM	PART	DESCRIPTION	QTY.
35	067854-000	ANGLE, RESERVOIR MOUNT	1
36	067856-000	WELDMENT, STIFFENER	1
37	011254-006	SCREW HHC 3/8-16 X 3/4	5
38	062125-016	CABLE, BATTERY X 16	1
39	062125-002	CABLE, BATTERY X 69	1
40	014435-001	TERMINAL, BATTERY	2
41	010154-000	COVER, BATTERY TERMINAL	2
42	011237-006	WASHER, 3/8 STAR INTERNAL	1
48	011248-005	NUT, HEX 5/16-18 ESNA	2
49	067892-000	BRACKET, VALVE BLOCK	1
50	067524-001	VALVE BLOCK ASSY. (4 W.D.)	1
51	011254-004	SCRW HHC GR5 3/8-16UNC X 1/2	4
52	063650-012	GAS SPRING	1
53	067902-000	BRACKET, GAS SPRING	1
54	015936-004	SCR, SHOULDER 3/8 DIA. X 1/2	2
55	067648-008	END FITTING, GAS SPRING	2
56	011253-008	SCR, HHC 5/16-18 X 1	2
102	029610-002	TERMINAL #6 FORK	12
103	029616-002	TERMINAL 16 GA FEMALE PUSH ON	18
104	029457-099	WIRE 16 GA - GREEN	4'
105	029451-099	WIRE 16 GA - WHITE	3'
106	029450-099	WIRE 16 GA - BLUE	3'
107	029452-099	WIRE 16 GA - BLACK	3'
108	029479-099	WIRE 16 GA - WHITE/BLACK	3'
109	029454-099	WIRE 16 GA - RED	3'
110	029453-099	WIRE 16 GA - ORANGE	3'
111	005491-099	WIRE 16 GA - GREEN/BLACK	3'
112	029477-099	WIRE 16 GA - ORANGE/BLACK	3'

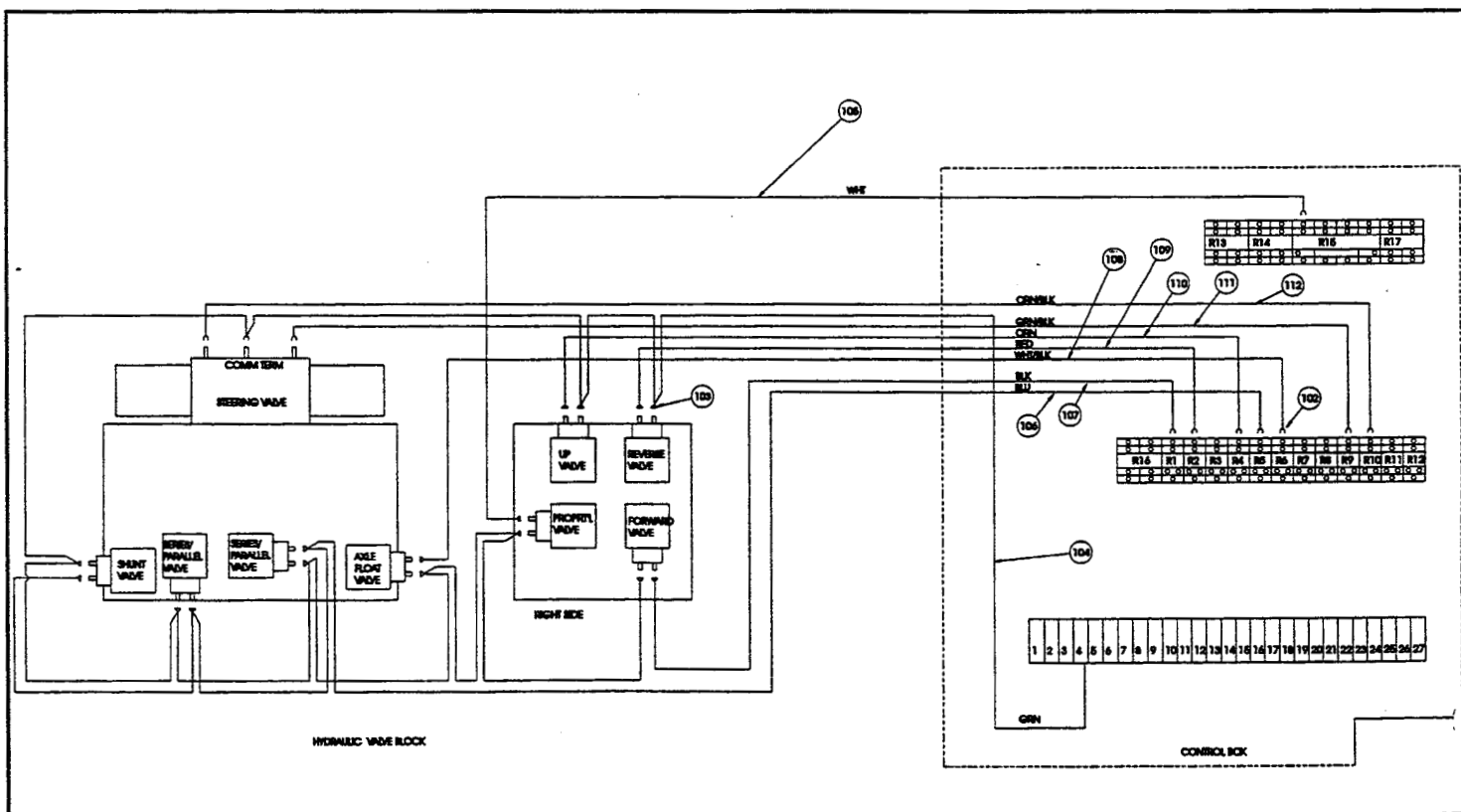

# Illustrated Parts Breakdown

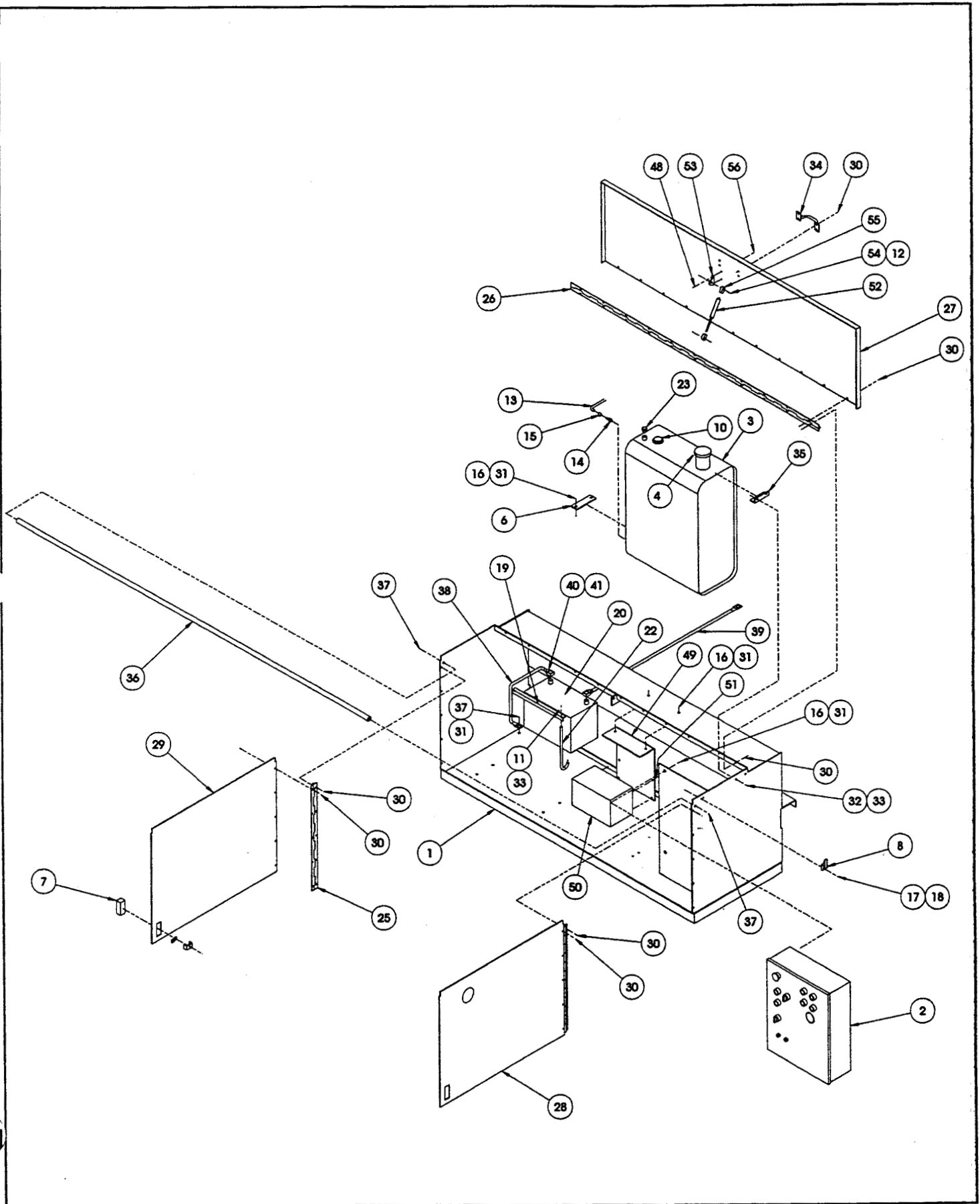

## CONTROL MODULE ASSEMBLY, LX50 FOUR WHEEL DRIVE DIESEL 067521-003

ITEM	PART	DESCRIPTION	QTY.
1	067810-000	CONTROL MODULE WELDMENT	1
2	067527-001	CONTROL BOX ASSY, DIESEL	1
3	067631-000	FUEL TANK, GASOLINE	1
4	063929-001	GAS CAP	1
6	064039-000	MOUNTING TAB, FUEL TANK	3
7	067629-000	LATCH, FLUSH LIFT & TURN	2
8	005299-000	LATCH, TOGGLE	2
10	063982-002	FUEL LEVEL GAGE	1
11	011240-004	WASHER 1/4 FLAT	2
13	012739-099	HOSE, 1/4 I.D.	11 FT
14	010178-003	FITTING, BARBED 1/4 X 4MP	1
15	020541-001	HOSE CLAMP	4
16	011254-008	SCRW HHC GR5 3/8-16UNC X 1	10
17	011708-004	SCRW MACH RD HD 8-32UNC X 1/2	4
18	011248-002	LOCK NUT, ESMA 8-32UNC	4
19	064040-000	ANGLE, BATTERY HOLD DOWN	1
20	062299-002	BATTERY, 12 VDC GROUP-27C	1
21	012736-099	HOSE 3/16 ID	11 FT
22	012039-000	ROD, BATTERY HOLD DOWN	2
23	003495-001	FITTING 90°2FP-2MP	1
24	010178-001	FITTING BARBED 3/16 X 2MP	1
25	067808-000	HINGE, 1 1/2 X 23 7/8	2
26	067809-000	HINGE, 1 1/2 X 65	1
27	067799-002	MODULE COVER / CONTROL	1
28	067800-000	MODULE DOOR, R.H.	1
29	067801-000	MODULE DOOR, L.H.	1
30	026554-002	POP RIVET, 1/4 DIA (.251-.375 GRIP)	46
31	011248-006	NUT, 3/8-16 ESNA	11
32	011252-006	SCREW, HHC 1/4-20 X 3/4	2
33	011248-004	NUT, 1/4-20 ESNA	4

ITEM	PART	DESCRIPTION	QTY.
34	025427-002	HANDLE	1
35	067854-000	ANGLE, RESERVOIR MOUNT	1
36	067856-000	WELDMENT, STIFFENER	1
37	011254-006	SCREW HHC 3/8-16 X 3/4	3
38	062125-016	CABLE, BATTERY X 16	1
39	062125-002	CABLE, BATTERY X 69	1
40	014435-001	TERMINAL, BATTERY	2
41	010154-000	COVER, BATTERY TERMINAL	2
42	003556-001	FITTING ADAPTER 2FP-4MP	1
43	011237-006	WASHER, 3/8 STAR INTERNAL	1
48	011248-005	NUT, HEX 5/16-18 ESNA	2
49	067892-000	BRACKET, VALVE BLOCK	1
50	067524-001	VALVE BLOCK ASSY. (4 W.D.)	1
51	011254-004	SCR HHC GR5 3/8-16UNC X 1/2	4
52	063650-012	GAS SPRING	1
53	067902-000	BRACKET, GAS SPRING	1
54	015936-004	SCREW, SHOULDER 3/8 DIA. X 1/2	2
55	067648-008	END FITTING, GAS SPRING	2
56	011253-008	SCR, HHC 5/16-18 X 1	2
102	029610-002	TERMINAL #6 FORK	12
103	029616-002	TERMINAL 16 GA FEMALE PUSH ON	18
104	029457-099	WIRE 16 GA - GREEN	4'
105	029451-099	WIRE 16 GA - WHITE	3'
106	029450-099	WIRE 16 GA - BLUE	3'
107	029452-099	WIRE 16 GA - BLACK	3'
108	029479-099	WIRE 16 GA - WHITE/BLACK	3'
109	029454-099	WIRE 16 GA - RED	3'
110	029453-099	WIRE 16 GA - ORANGE	3'
111	005491-099	WIRE 16 GA - GREEN/BLACK	3'
112	029477-099	WIRE 16 GA - ORANGE/BLACK	3'

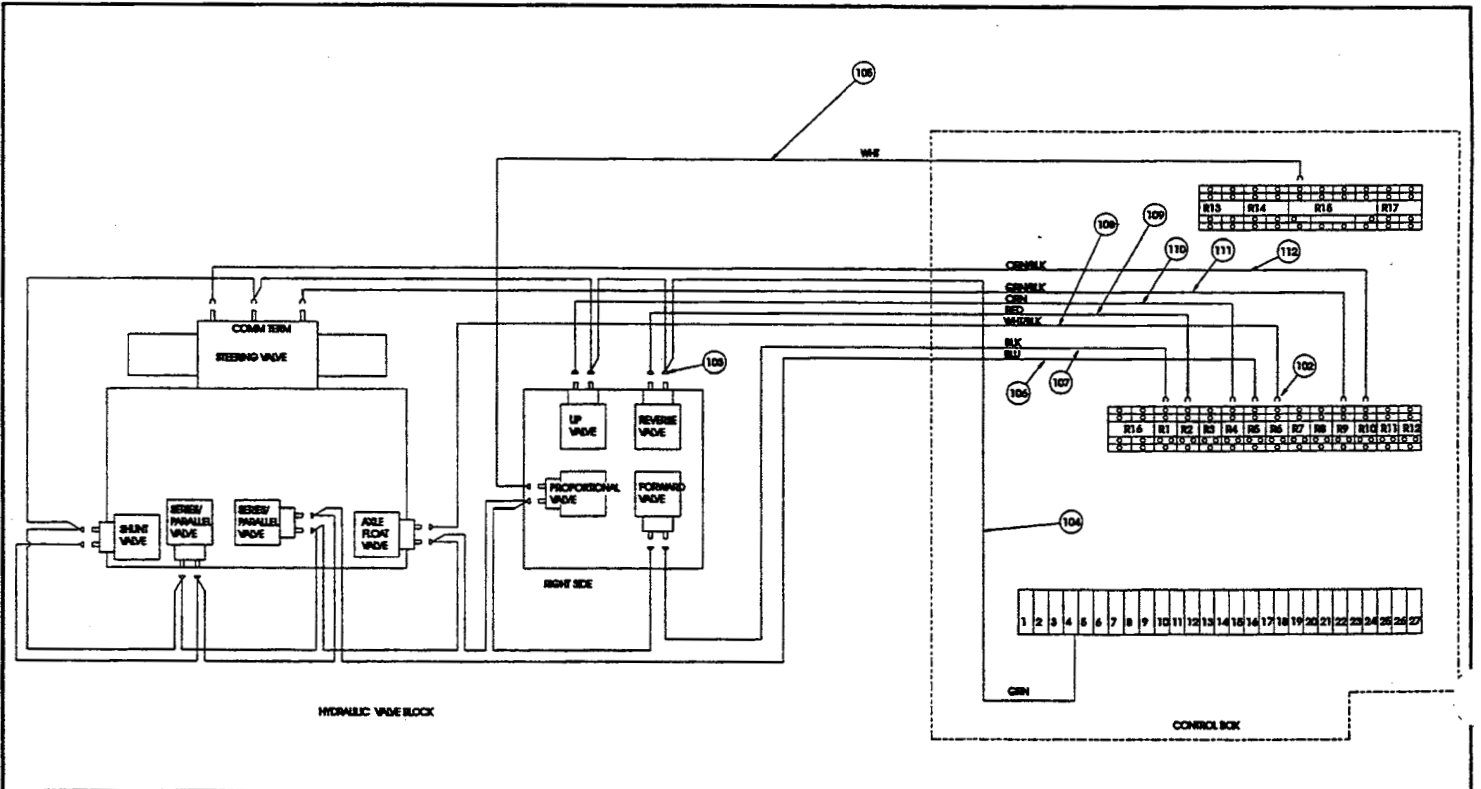

# Illustrated Parts Breakdown

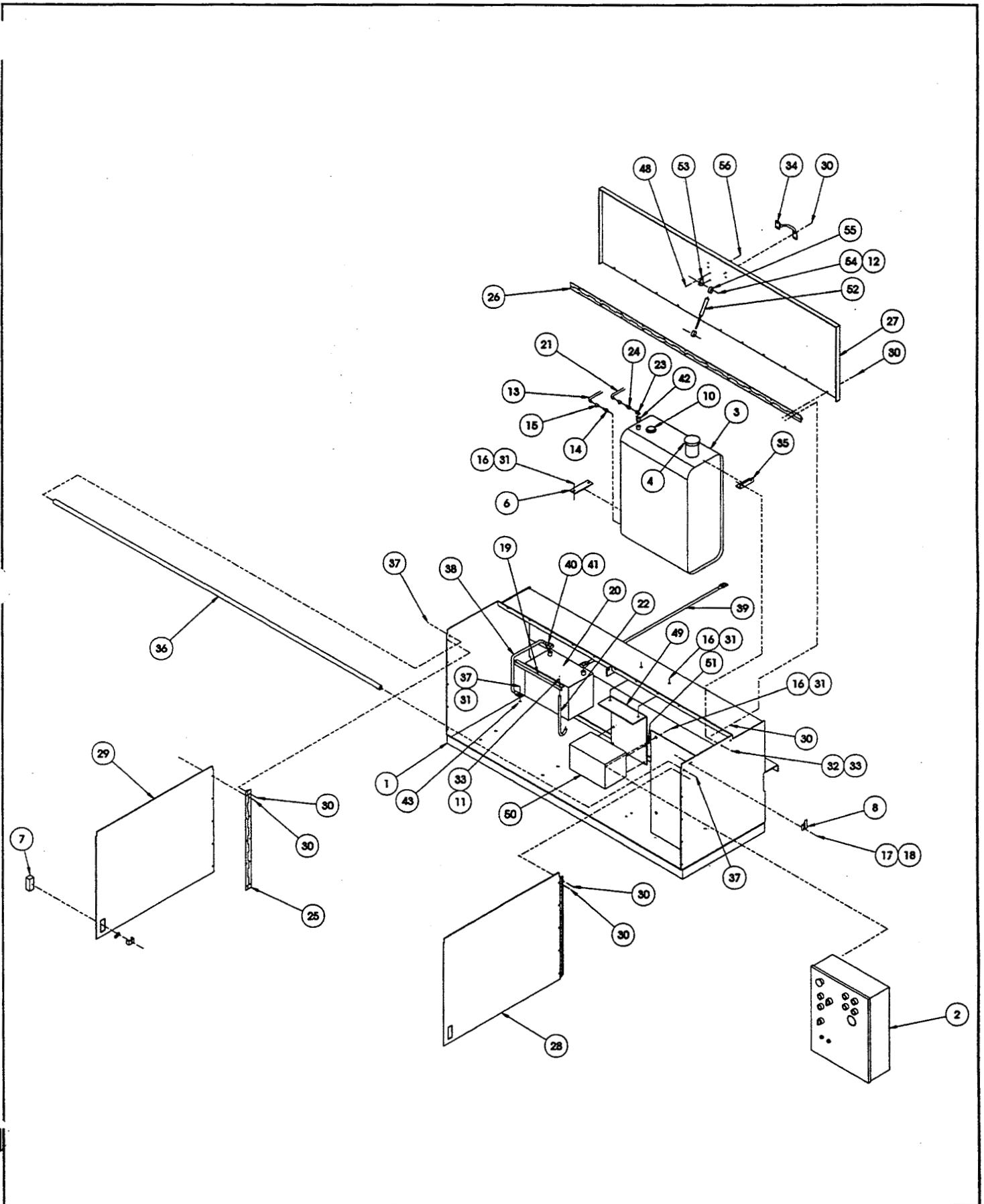

## CONTROL MODULE ASSEMBLY, LX50 Two Wheel Drive Gas, Dual Deck 067521-004

ITEM	PART	DESCRIPTION	QTY.
1	067810-002	CONTROL MODULE WELDMENT	1
2	067527-002	CONTROL BOX ASSY, GAS	1
3	067631-000	FUEL TANK	1
4	063929-001	GAS CAP	1
6	064039-000	MOUNTING TAB, FUEL TANK	3
7	067629-000	LATCH, FLUSH LIFT & TURN	2
8	005299-000	LATCH, TOGGLE	2
10	063982-002	FUEL LEVEL GAGE	1
11	011240-004	WASHER 1/4 FLAT	2
13	012739-099	HOSE, 1/4 I.D.	11 FT
14	010178-003	FITTING, BARBED 1/4 X 4MP	1
15	020541-001	HOSE CLAMP	2
16	011254-008	SCRW HHC GR5 3/8-16UNC X 1	10
17	011708-004	SCRW MACH RD HD 8-32UNC X 1/2	6
18	011248-002	LOCK NUT, ESMA 8-32UNC	6
19	064040-000	ANGLE, BATTERY HOLD DOWN	1
20	062299-002	BATTERY, 12 VDC GROUP-27C	1
22	012039-000	ROD, BATTERY HOLD DOWN	2
23	011920-002	FITTING, PLUG	1
25	067808-000	HINGE, 1 1/2 X 23 7/8	2
26	067809-000	HINGE, 1 1/2 X 65	1
27	030841-039	MODULE COVER / CONTROL	1
28	030841-031	MODULE DOOR, R.H.	1
29	030841-032	MODULE DOOR, L.H.	1
30	026554-002	POP RIVET, 1/4 DIA (.251-.375 GRIP)	50
31	011248-006	NUT, 3/8-16 ESNA	11
32	011252-006	SCREW, HHC 1/4-20 X 3/4	2
33	011248-004	NUT, 1/4-20 ESNA	4
34	025427-002	HANDLE	2

ITEM	PART	DESCRIPTION	QTY.
35	067854-000	ANGLE, RESERVOIR MOUNT	1
36	030841-030	WELDMENT, STAIR	1
37	011254-006	SCREW HHC 3/8-16 X 3/4	3
38	062125-016	CABLE, BATTERY X 16	1
39	062125-002	CABLE, BATTERY X 69	1
40	014435-001	TERMINAL, BATTERY	2
41	010154-000	COVER, BATTERY TERMINAL	2
42	011237-006	WASHER, STAR INTERNAL 3/8	1
48	011248-005	NUT, HEX 5/16-18 ESNA	2
49	067892-000	BRACKET, VALVE BLOCK	1
50	067524-000	VALVE BLOCK ASSY. (2 W.D.)	1
51	011254-004	SCR HHC GR5 3/8-16UNC X 1/2	4
52	063650-012	GAS SPRING	1
53	067902-000	BRACKET, GAS SPRING	1
54	015936-004	SCR, SHOULDER 3/8 DIA.X 1/2	2
55	067648-008	END FITTING, GAS SPRING	2
56	011253-008	SCR, HHC 5/16-18 X 1	2
102	029610-002	TERMINAL #6 FORK	12
103	029616-002	TERMINAL 16 GA FEMALE PUSH ON	18
104	029457-099	WIRE 16 GA - GREEN	4'
105	029451-099	WIRE 16 GA - WHITE	3'
106	029450-099	WIRE 16 GA - BLUE	3'
107	029452-099	WIRE 16 GA - BLACK	3'
109	029454-099	WIRE 16 GA - RED	3'
110	029453-099	WIRE 16 GA - ORANGE	3'
111	005491-099	WIRE 16 GA - GREEN/BLACK	3'
112	029477-099	WIRE 16 GA - ORANGE/BLACK	3'

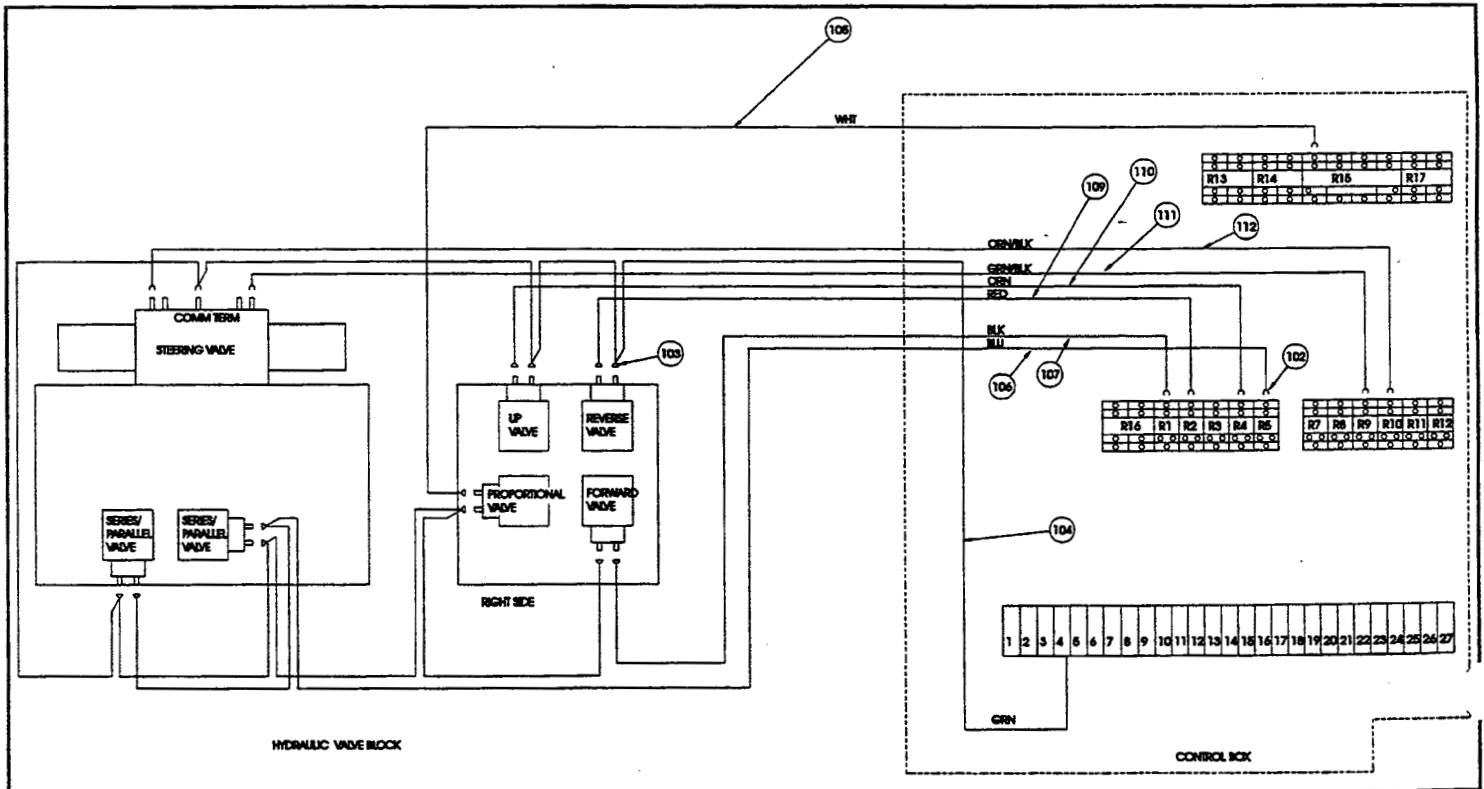

# Illustrated Parts Breakdown

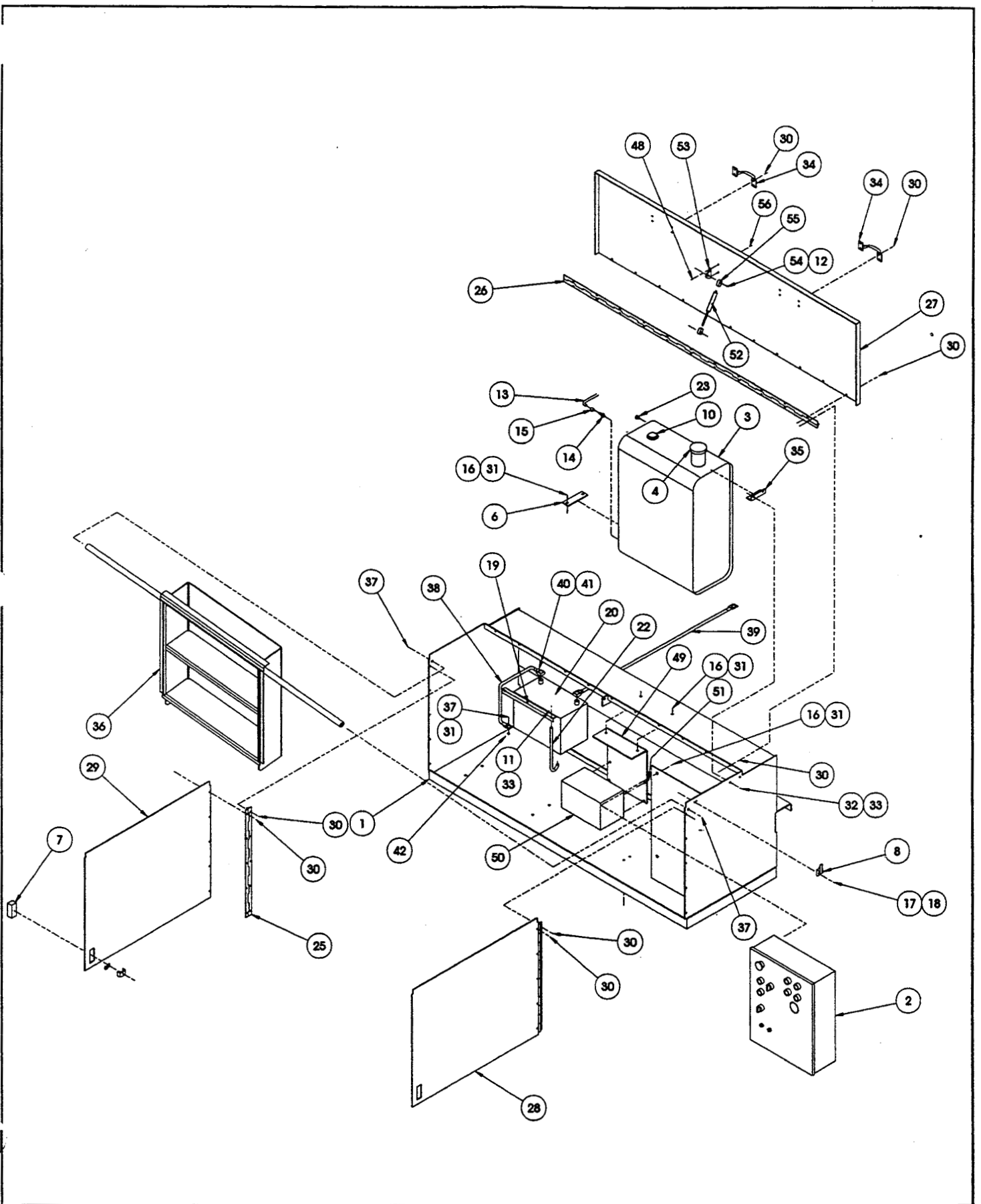



## CONTROL MODULE ASSEMBLY, LX50 Two Wheel Drive Diesel, Dual Deck 067521-005

ITEM	PART	DESCRIPTION	QTY.
1	067810-002	CONTROL MODULE WELDMENT	1
2	067527-003	CONTROL BOX ASSY, DIESEL	1
3	067631-000	FUEL TANK	1
4	063929-001	GAS CAP	1
6	064039-000	MOUNTING TAB, FUEL TANK	3
7	067629-000	LATCH, FLUSH LIFT & TURN	2
8	005299-000	LATCH, TOGGLE	2
10	063982-002	FUEL LEVEL GAGE	1
11	011240-004	WASHER 1/4 FLAT	2
13	012739-099	HOSE, 1/4 I.D.	11 FT
14	010178-003	FITTING, BARBED 1/4 X 4MP	1
15	020541-001	HOSE CLAMP	4
16	011254-008	SCRW HHC GR5 3/8-16UNC X 1	10
17	011708-004	SCRW MACH RD HD 8-32UNC X 1/2	6
18	011248-002	LOCK NUT, ESMA 8-32UNC	6
19	064040-000	ANGLE, BATTERY HOLD DOWN	1
20	062299-002	BATTERY, 12 VDC GROUP-27C	1
21	012736-099	HOSE 3/16 ID	11 FT
22	012039-000	ROD, BATTERY HOLD DOWN	2
23	003495-001	FITTING 90°4FP-4MP	1
24	010178-001	FITTING BARBED 3/16 X 4MP	1
25	067808-000	HINGE, 1 1/2 X 23 7/8	2
26	067809-000	HINGE, 1 1/2 X 65	1
27	030841-039	MODULE COVER / CONTROL	1
28	030841-031	MODULE DOOR, R.H.	1
29	030841-032	MODULE DOOR, L.H.	1
30	026554-002	POP RIVET, 1/4 DIA (.251-.375 GRIP)	50
31	011248-006	NUT, 3/8-16 ESNA	11
32	011252-006	SCREW, HHC 1/4-20 X 3/4	2

ITEM	PART	DESCRIPTION	QTY.
33	011248-004	NUT, 1/4-20 ESNA	4
34	025427-002	HANDLE	2
35	067854-000	ANGLE, RESERVOIR MOUNT	1
36	030841-030	WELDMENT, STAIR	1
37	011254-006	SCREW HHC 3/8-16 X 3/4	3
38	062125-016	CABLE, BATTERY X 16	1
39	062125-002	CABLE, BATTERY X 69	1
40	014435-001	TERMINAL, BATTERY	2
41	010154-000	COVER, BATTERY TERMINAL	2
42	011237-006	WASHER, STAR INTERNAL 3/8	1
48	011248-005	NUT, HEX 5/16-18 ESNA	2
49	067892-000	BRACKET, VALVE BLOCK	1
50	067524-000	VALVE BLOCK ASSY. (2 W.D.)	1
51	011254-004	SCR HHC GR5 3/8-16UNC X 1/2	4
52	063650-012	GAS SPRING	1
53	067902-000	BRACKET, GAS SPRING	1
54	015936-004	SCR, SHOULDER 3/8 DIA.X 1/2	2
55	067648-008	END FITTING, GAS SPRING	2
56	011253-008	SCR, HHC 5/16-18 X 1	2
102	029610-002	TERMINAL #6 FORK	12
103	029616-002	TERMINAL 16 GA FEMALE PUSH ON	18
104	029457-099	WIRE 16 GA - GREEN	4'
105	029451-099	WIRE 16 GA - WHITE	3'
106	029450-099	WIRE 16 GA - BLUE	3'
107	029452-099	WIRE 16 GA - BLACK	3'
109	029454-099	WIRE 16 GA - RED	3'
110	029453-099	WIRE 16 GA - ORANGE	3'
111	005491-099	WIRE 16 GA - GREEN/BLACK	3'
112	029477-099	WIRE 16 GA - ORANGE/BLACK	3'

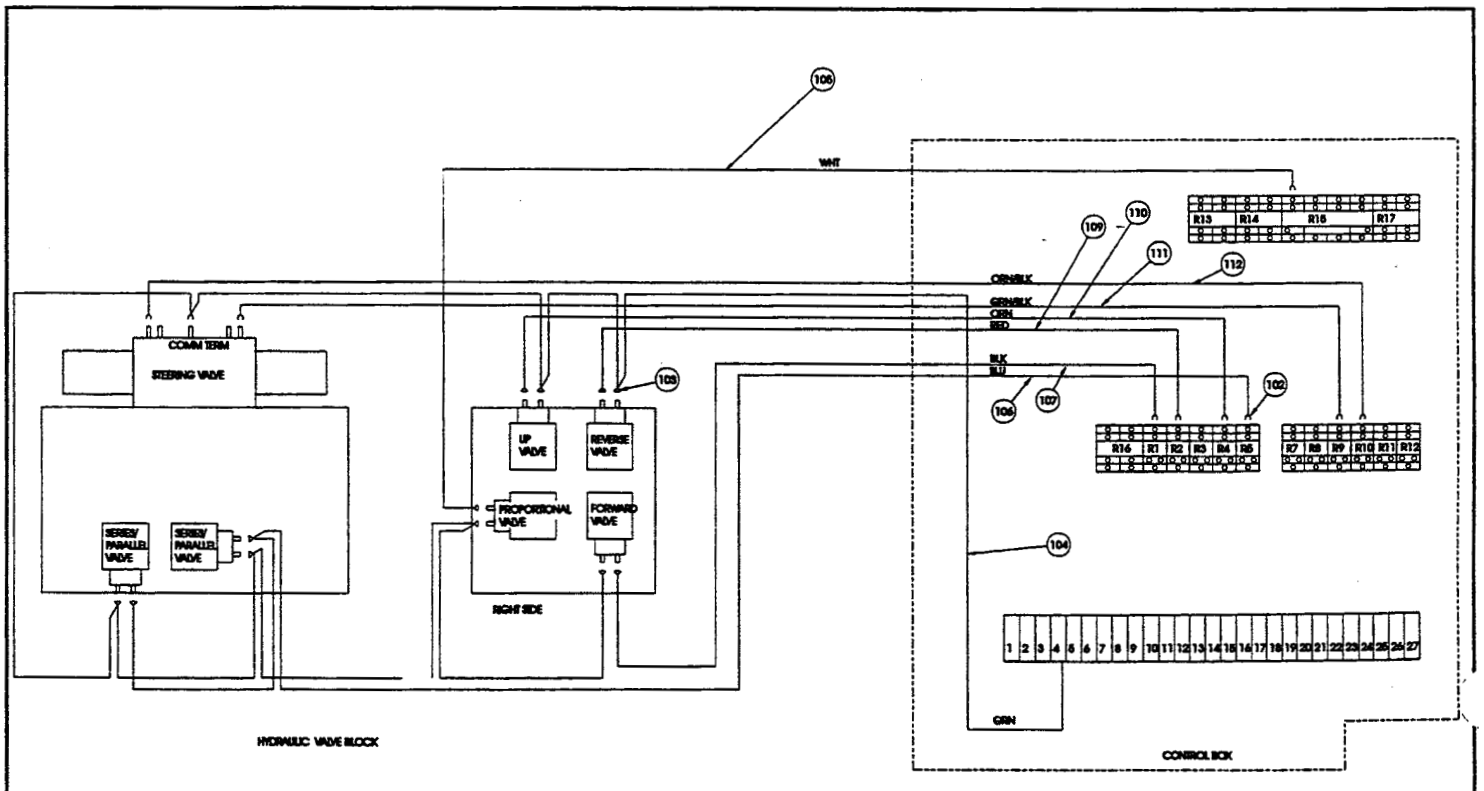

# Illustrated Parts Breakdown

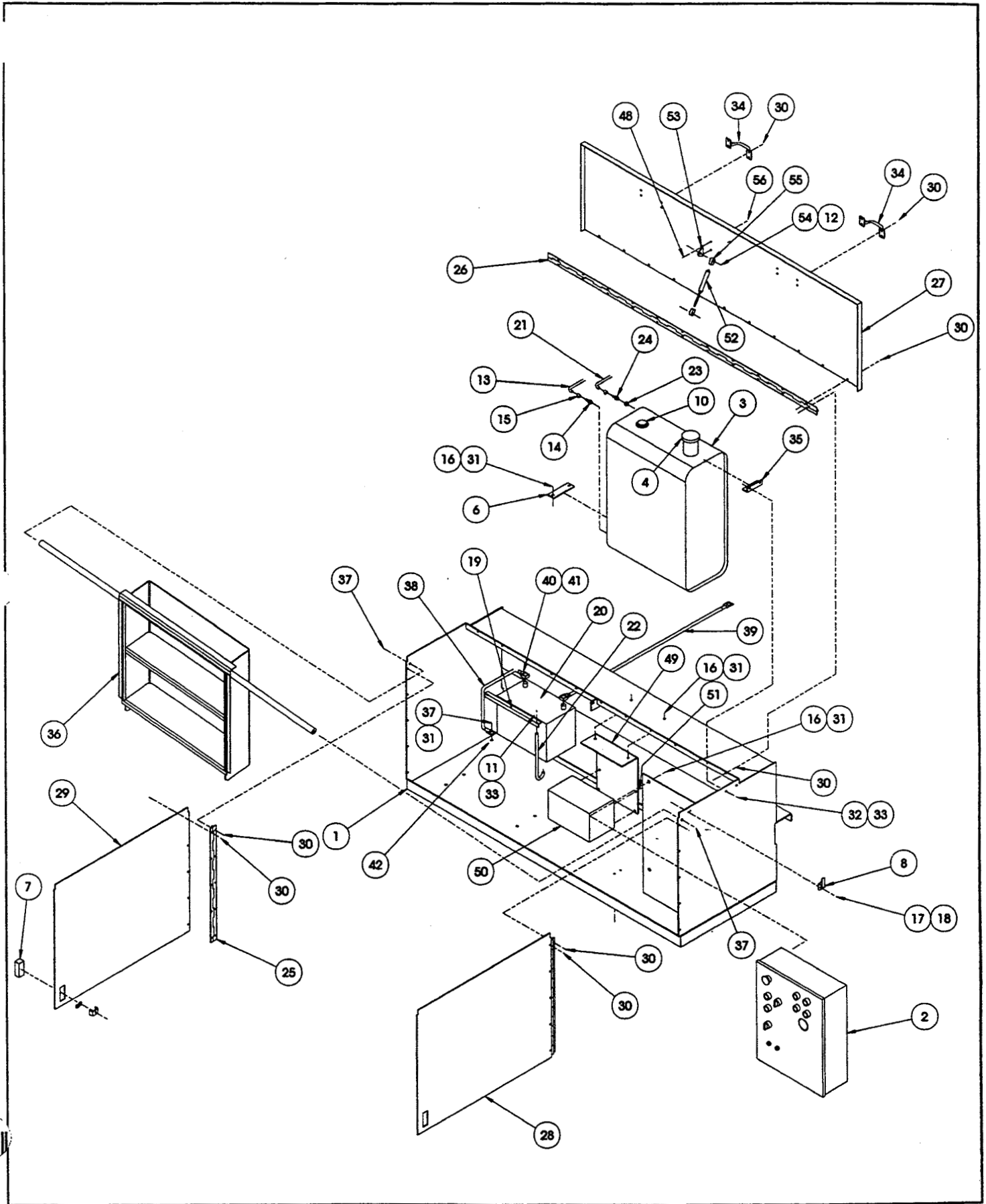

# Illustrated Parts Breakdown

## CONTROL MODULE ASSEMBLY, LX50 FOUR WHEEL DRIVE GAS, DUAL DECK 067521-006

ITEM	PART	DESCRIPTION	QTY.
1	067810-002	CONTROL MODULE WELDMENT	1
2	067527-000	CONTROL BOX ASSY, GAS	1
3	067631-000	FUEL TANK	1
4	063929-001	GAS CAP	1
6	064039-000	MOUNTING TAB, FUEL TANK	3
7	067629-000	LATCH, FLUSH LIFT & TURN	2
8	005299-000	LATCH, TOGGLE	2
10	063982-002	FUEL LEVEL GAGE	1
11	011240-004	WASHER 1/4 FLAT	2
13	012739-099	HOSE, 1/4 I.D.	11 FT
14	010178-003	FITTING, BARBED 1/4 X 4MP	1
15	020541-001	HOSE CLAMP	2
16	011254-008	SCRW HHC GR5 3/8-16UNC X 1	10
17	011708-004	SCRW MACH RD HD 8-32UNC X 1/2	6
18	011248-002	LOCK NUT, ESMA 8-32UNC	6
19	064040-000	ANGLE, BATTERY HOLD DOWN	1
20	062299-002	BATTERY, 12 VDC GROUP-27C	1
22	012039-000	ROD, BATTERY HOLD DOWN	2
23	011920-002	FITTING, PLUG	1
25	067808-000	HINGE, 1 1/2 X 23 7/8	2
26	067809-000	HINGE, 1 1/2 X 65	1
27	030841-039	MODULE COVER / CONTROL	1
28	030841-031	MODULE DOOR, R.H.	1
29	030841-032	MODULE DOOR, L.H.	1
30	026554-002	POP RIVET, 1/4 DIA (.251-.375 GRIP)	50
31	011248-006	NUT, 3/8-16 ESNA	11
32	011252-006	SCREW, HHC 1/4-20 X 3/4	2
33	011248-004	NUT, 1/4-20 ESNA	4
34	025427-002	HANDLE	2

ITEM	PART	DESCRIPTION	QTY.
35	067854-000	ANGLE, RESERVOIR MOUNT	1
36	030841-030	WELDMENT, STAIR	1
37	011254-006	SCREW HHC 3/8-16 X 3/4	3
38	062125-016	CABLE, BATTERY X 16	1
39	062125-002	CABLE, BATTERY X 69	1
40	014435-001	TERMINAL, BATTERY	2
41	010154-000	COVER, BATTERY TERMINAL	2
42	011237-006	WASHER, STAR INTERNAL 3/8	1
47	065242-000	LATCH SPACER	2
48	011248-005	NUT, HEX 5/16-18 ESNA	2
49	067892-000	BRACKET, VALVE BLOCK	1
50	067524-001	VALVE BLOCK ASSY. (4 W.D.)	1
51	011254-004	SCR HHC GR5 3/8-16UNC X 1/2	4
52	063650-012	GAS SPRING	1
53	067902-000	BRACKET, GAS SPRING	1
54	015936-004	SCR, SHOULDER 3/8 DIA. X 1/2	2
55	067648-008	END FITTING, GAS SPRING	2
56	011253-008	SCR, HHC 5/16-18 X 1	2
102	029610-002	TERMINAL #6 FORK	12
103	029616-002	TERMINAL 16 GA FEMALE PUSH ON	18
104	029457-099	WIRE 16 GA - GREEN	4'
105	029451-099	WIRE 16 GA - WHITE	3'
106	029450-099	WIRE 16 GA - BLUE	3'
107	029452-099	WIRE 16 GA - BLACK	3'
108	029479-099	WIRE 16 GA - WHITE/BLACK	3'
109	029454-099	WIRE 16 GA - RED	3'
110	029453-099	WIRE 16 GA - ORANGE	3'
111	005491-099	WIRE 16 GA - GREEN/BLACK	3'
112	029477-099	WIRE 16 GA - ORANGE/BLACK	3'

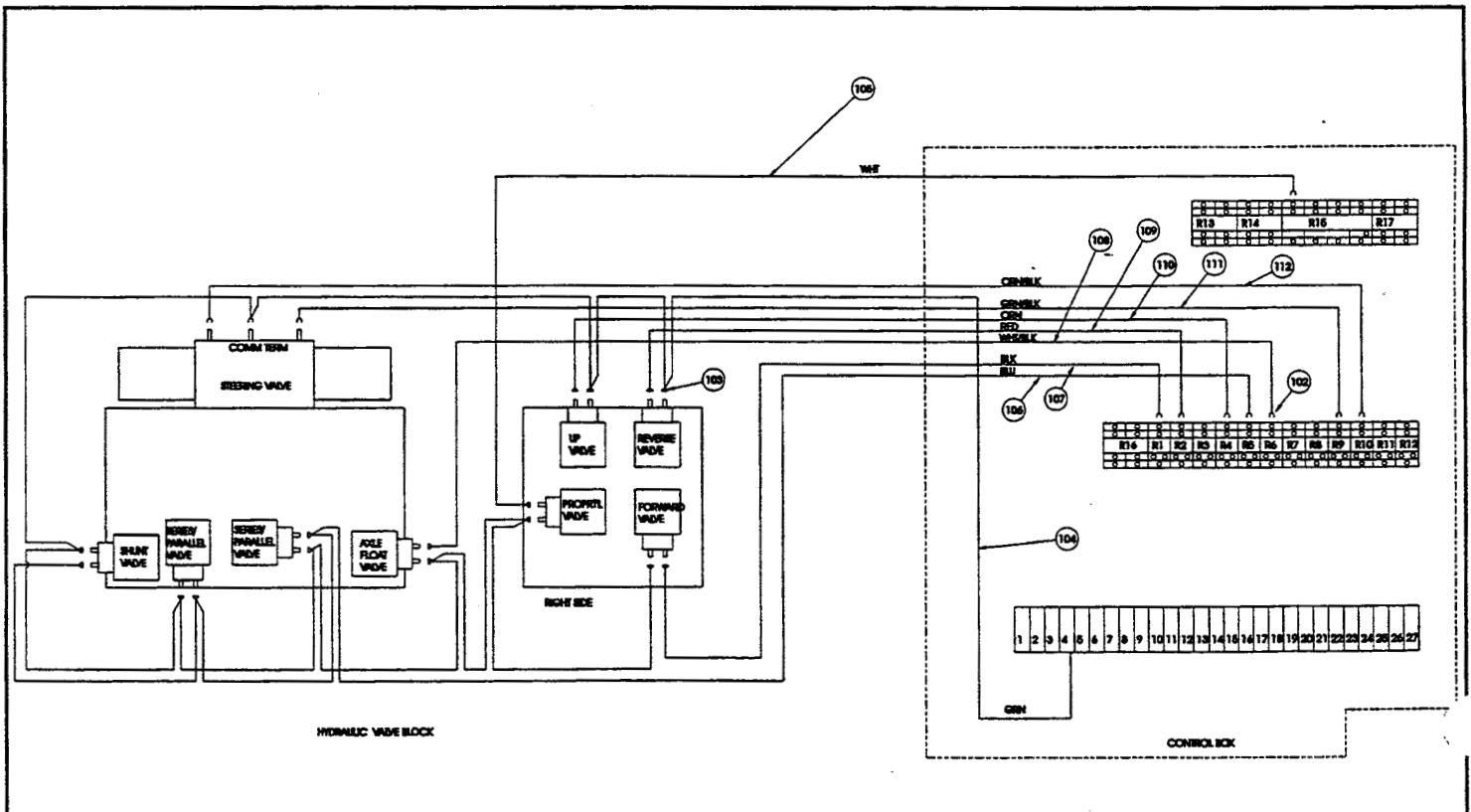

# Illustrated Parts Breakdown

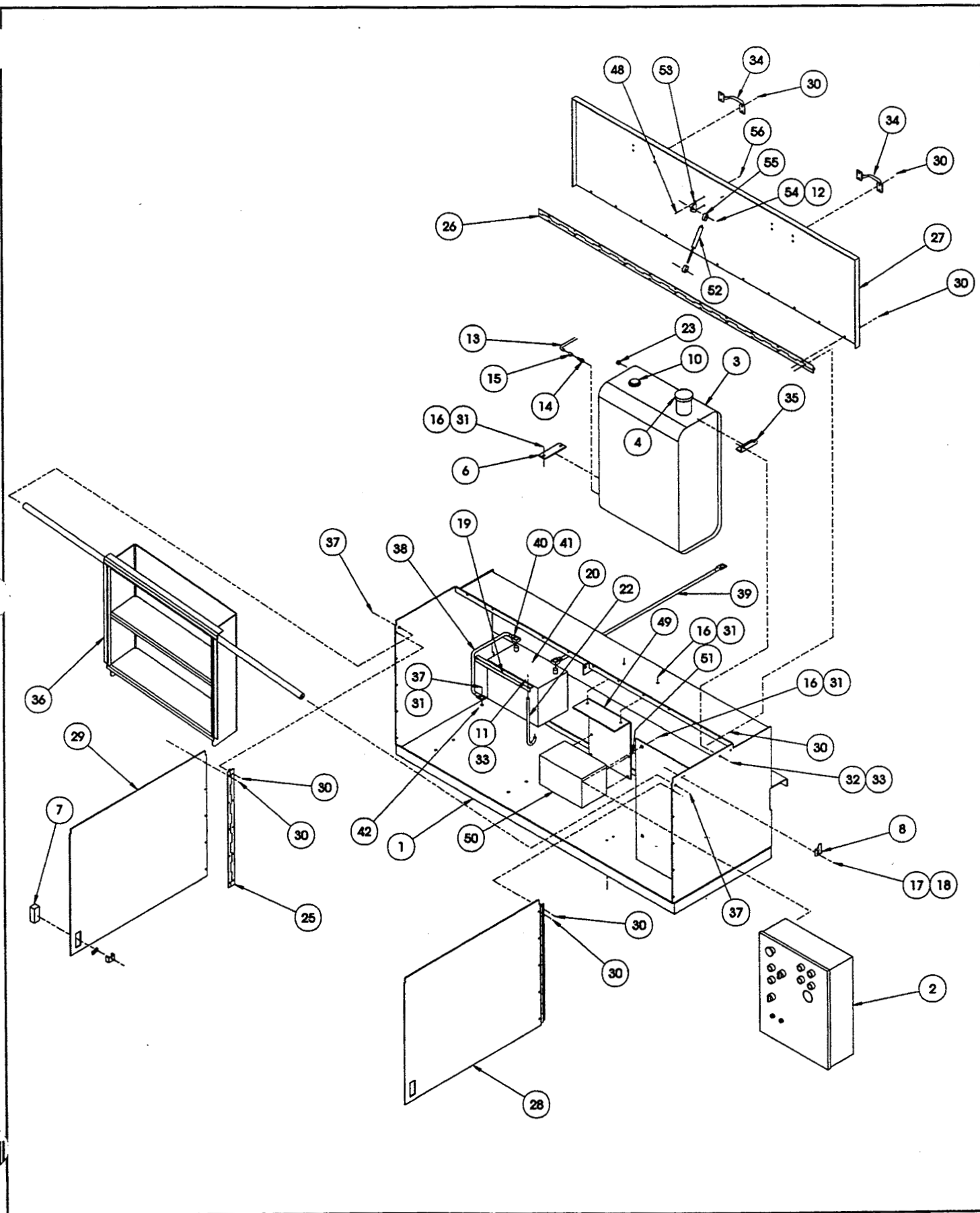

# Illustrated Parts Breakdown

## CONTROL MODULE ASSEMBLY, LX50 FOUR WHEEL DRIVE DIESEL, DUAL DECK 067521-007

ITEM	PART	DESCRIPTION	QTY.
1	067810-002	CONTROL MODULE WELDMENT	1
2	067527-001	CONTROL BOX ASSY, DIESEL	1
3	067631-000	FUEL TANK	1
4	063929-001	GAS CAP	1
6	064039-000	MOUNTING TAB, FUEL TANK	3
7	067629-000	LATCH, FLUSH LIFT & TURN	2
8	005299-000	LATCH, TOGGLE	2
10	063982-002	FUEL LEVEL GAGE	1
11	011240-004	WASHER 1/4 FLAT	2
13	012739-099	HOSE, 1/4 I.D.	11 FT
14	010178-003	FITTING, BARBED 1/4 X 4MP	1
15	020541-001	HOSE CLAMP	4
16	011254-008	SCRW HHC GR5 3/8-16UNC X 1	10
17	011708-004	SCRW MACH RD HD 8-32UNC X 1/2	6
18	011248-002	LOCK NUT, ESMA 8-32UNC	6
19	064040-000	ANGLE, BATTERY HOLD DOWN	1
20	062299-002	BATTERY, 12 VDC GROUP-27C	1
21	012736-099	HOSE 3/16 ID	11 FT
22	012039-000	ROD, BATTERY HOLD DOWN	2
23	003495-001	FITTING 90°4FP-4MP	1
24	010178-001	FITTING BARBED 3/16 X 4MP	1
25	067808-000	HINGE, 1 1/2 X 23 7/8	2
26	067809-000	HINGE, 1 1/2 X 65	1
27	030841-039	MODULE COVER / CONTROL	1
28	030841-031	MODULE DOOR, R.H.	1
32	011252-006	SCREW, HHC 1/4-20 X 3/4	2
29	030841-032	MODULE DOOR, L.H.	1
30	026554-002	POP RIVET, 1/4 DIA (.251-.375 GRIP)	50
31	011248-006	NUT, 3/8-16 ESNA	11

ITEM	PART	DESCRIPTION	QTY.
33	011248-004	NUT, 1/4-20 ESNA	4
34	025427-002	HANDLE	2
35	067854-000	ANGLE, RESERVOIR MOUNT	1
36	030841-030	WELDMENT, STAIR	1
37	011254-006	SCREW HHC 3/8-16 X 3/4	3
38	062125-016	CABLE, BATTERY X 16	1
39	062125-002	CABLE, BATTERY X 69	1
40	014435-001	TERMINAL, BATTERY	2
41	010154-000	COVER, BATTERY TERMINAL	2
42	011237-006	WASHER, STAR INTERNAL 3/8	1
48	011248-005	NUT, HEX 5/16-18 ESNA	2
49	067892-000	BRACKET, VALVE BLOCK	1
50	067524-001	VALVE BLOCK ASSY. (4 W.D.)	1
51	011254-004	SCR HHC GR5 3/8-16UNC X 1/2	4
52	063650-012	GAS SPRING	1
53	067902-000	BRACKET, GAS SPRING	1
54	015936-004	SCR, SHOULDER 3/8 DIA.X 1/2	2
55	067648-008	END FITTING, GAS SPRING	2
56	011253-008	SCR, HHC 5/16-18 X 1	2
102	029610-002	TERMINAL #6 FORK	12
103	029616-002	TERMINAL 16 GA FEMALE PUSH ON	18
104	029457-099	WIRE 16 GA - GREEN	4'
105	029451-099	WIRE 16 GA - WHITE	3'
106	029450-099	WIRE 16 GA - BLUE	3'
107	029452-099	WIRE 16 GA - BLACK	3'
108	029479-099	WIRE 16 GA - WHITE/BLACK	3'
109	029454-099	WIRE 16 GA - RED	3'
110	029453-099	WIRE 16 GA - ORANGE	3'
111	005491-099	WIRE 16 GA - GREEN/BLACK	3'
112	029477-099	WIRE 16 GA - ORANGE/BLACK	3'

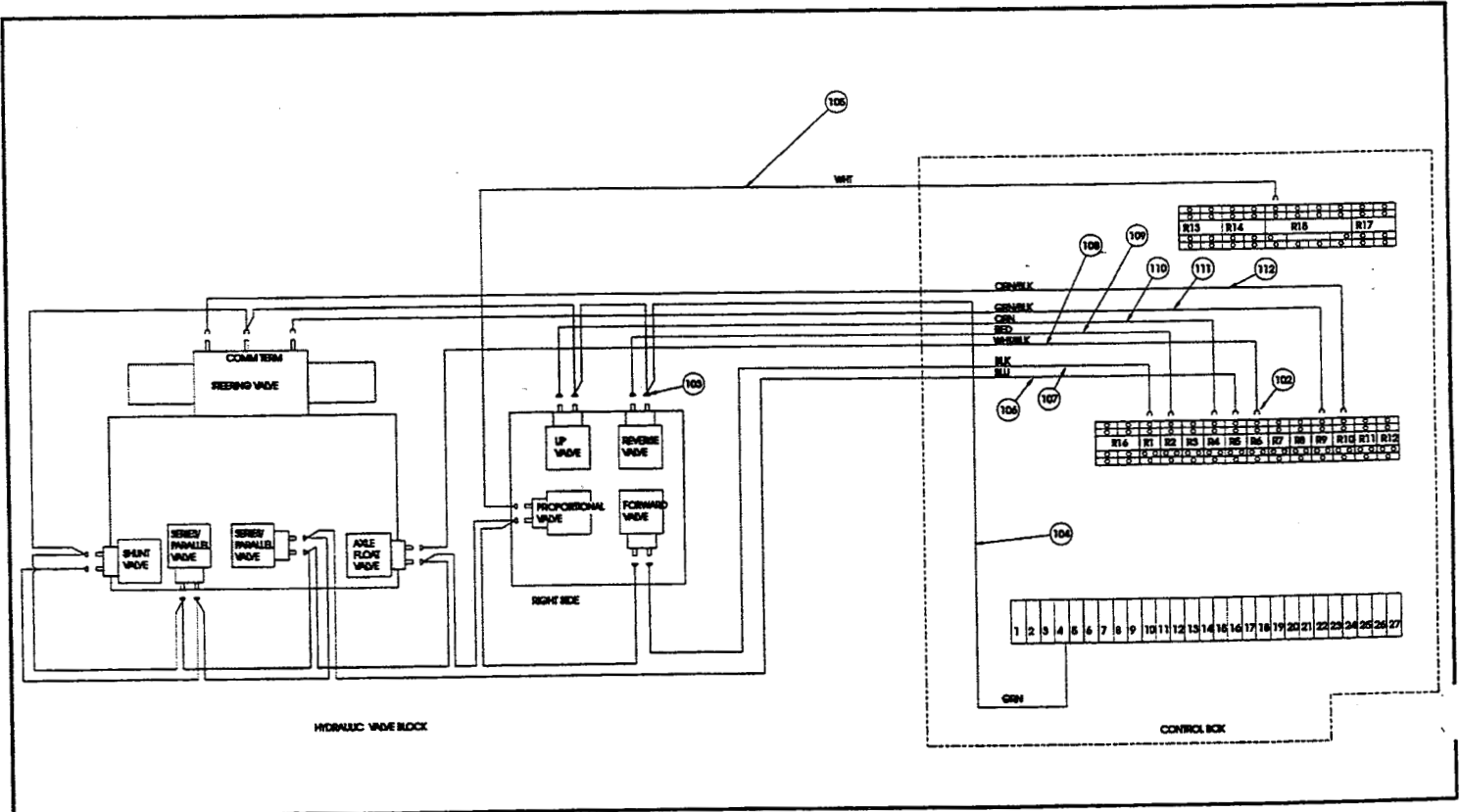

# Illustrated Parts Breakdown

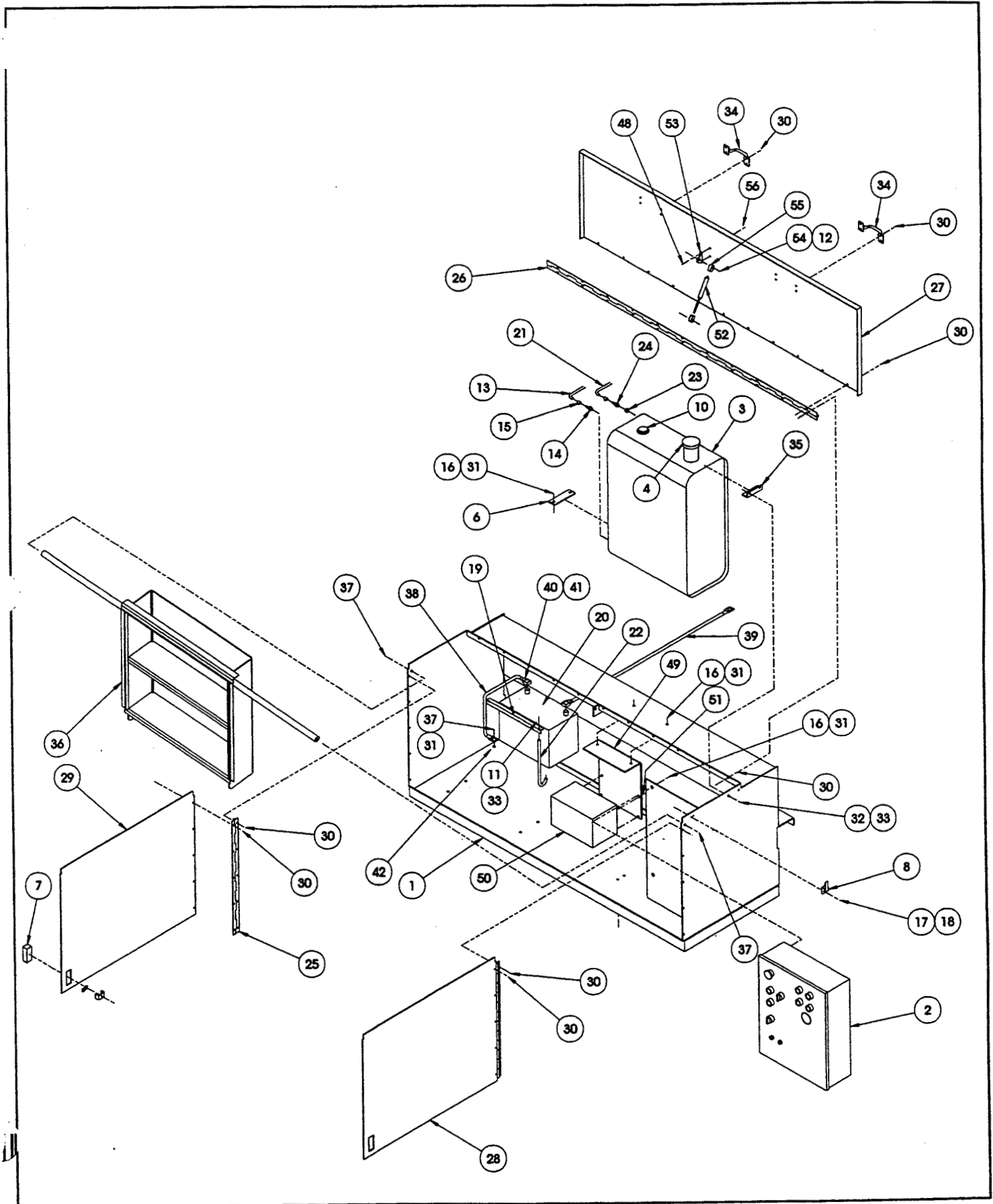

## POWER MODULE ASSEMBLY, LX50

GAS

067522-001

ITEM	PART	DESCRIPTION	QTY.
1	067809-000	HINGE, 2 X 65	1
2	067811-000	POWER MODULE WELDMENT	1
3	067800-001	MODULE DOOR, R.H.	1
4	067801-001	MODULE DOOR, L.H.	1
5	067799-000	MODULE COVER	1
6	067808-000	HINGE, 2 X 22	2
7	026554-002	POP RIVET, 1/4 DIA. (.251 - .375 GRIP)	42
8	005299-000	LATCH, TOGGLE	2
9	067629-000	LATCH, FLUSH LIFT & TURN	2
10	067523-001	ENGINE ASSY, DUAL FUEL KUBOTA	1
11	011939-021	FITTING 12MP-12MJ	1
12	014220-009	FITTING 16MP-12FP	1
13	063935-001	SUCTION SCREEN	1
14	067841-000	TANK, HYDRAULIC	1
15	067827-000	STEERING VALVE BRACKET	1
16	025427-002	HANDLE	1
17	026533-002	RIVET POP, 3/16D .126 -.250 GRIP	4
18	067856-000	STIFFENER BAR	1
19	011708-004	SCREW RD HD 8-32 X 1/2	4
20	011248-002	NUT HEX 8-32 ESNA	4
21	011254-006	SCREW HHC 3/8-16 X 3/4	2
22	064039-001	HYDRAULIC TANK MOUNTING TAB	1
23	067624-000	HYDRAULIC FILTER	1
*	067624-010	ELEMENT, FILTER	1
24	011916-011	ELBOW 90° 20FP-20FP (1-1/4 NPT)	1
25	067854-000	ANGLE RES. MOUNT	1
26	011240-006	WASHER 3/8 FLAT STD	26
27	011254-008	SCREW HHC 3/8-16 X 1	12
28	011248-006	NUT HEX 3/8-16 ESNA	14
29	063650-012	SPRING, PRESSURIZED GAS	1
30	067648-008	END FITTING, GAS SPRING	2
31	015936-004	SCREW SHOULDER 3/8Ø X 1/2	2
32	014902-005	FITTING TEE 12MP-12FP	1
33	011939-030	FITTING 20MP-20MJ	1

ITEM	PART	DESCRIPTION	QTY.
34	011923-008	FITTING 12MP-6FP	1
35	011940-008	FITTING 90° 6MP-4MJ	1
36	067898-000	RADIATOR COVER	1
37	063930-001	BREATHER/FILLER CAP	1
38	021305-007	PLUG, MAGNETIC	1
39	067696-000	EXHAUST TUBE, DUAL FUEL	1
40	067902-000	BRACKET, GAS SPRING	1
41	010070-099	SEAL STRIP GASKET	FT1.62
42	067691-001	SNORKEL WELDMENT, DUAL FUEL	1
43	013259-007	MUFFLER CLAMP 1 3/4	1
44	067697-000	BREATHER SPACER (RADIATOR)	1
45	011252-008	SCREW HHC 1/4-20 X 1	10
46	011240-004	WASHER FLAT STD 1/4	10
47	064462-023	PLUG, 3/8 CAP	2
48	013259-006	CLAMP, MUFFLER 1-1/2"	2
49	063979-006	GAGE, LUBE SIGHT	1
50	011248-004	NUT HEX ESNA 1/4-20	6
51	066697-099	PIPE INSULATION 1-3/8ØØ	1
52	011248-005	NUT HEX 5/16-18 ESNA	2
53	011253-007	SCREW HHC 5/16-18 X 7/8	4
54	011240-005	WASHER 5/16 FLAT STD	4
55	011238-005	WASHER LOCK 5/16	4
56	011250-005	NUT HEX 5/16-18	4
57	011923-007	FITTING 12MP-4FP	1
58	011940-004	FITTING 90°-4MP-4MJ	1
59	011939-013	FITTING 8MP-4MJ	1
60	011939-015	FITTING 8MP-8MJ	1
61	011939-014	FITTING 8MP-6MJ	1
62	063936-004	MUFFLER GASKET	1
63	067765-000	TUBE EXTENSION	1
64	011253-008	SCREW, HHC 5/16-18 X 1	2
65	011248-005	NUT, HEX 5/16-18 ESNA	2

# Illustrated Parts Breakdown

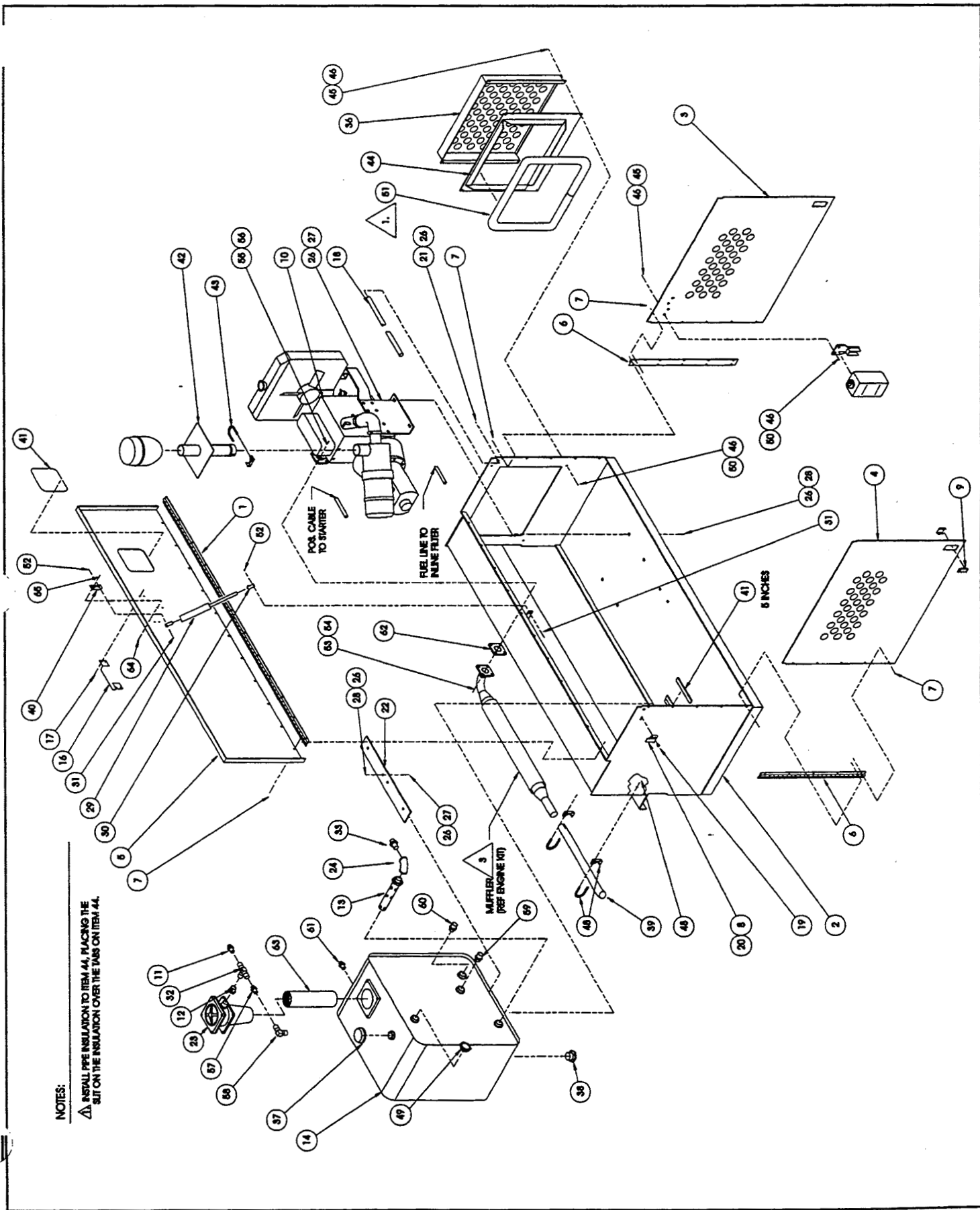



## POWER MODULE ASSEMBLY, LX50

DIESEL

067522-002

ITEM	PART	DESCRIPTION	QTY.
1	067809-000	HINGE, 2 X 65	1
2	067811-000	POWER MODULE WELDMENT	1
3	067800-001	MODULE DOOR, R.H.	1
4	067801-001	MODULE DOOR, L.H.	1
5	067799-001	MODULE COVER (DIESEL)	1
6	067808-000	HINGE, 2 X 22	2
7	026554-002	POP RIVET, 1/4 DIA. (.251 - .375 GRIP)	42
8	005299-000	LATCH, TOGGLE	2
9	067629-000	LATCH, FLUSH LIFT & TURN	2
10	067523-002	ENGINE ASSY, DIESEL KUBOTA	1
11	011939-021	FITTING 12MP-12MJ	1
12	014220-009	FITTING 16MP-12FP	1
13	063935-001	SUCTION SCREEN	1
14	067841-000	TANK, HYDRAULIC	1
15	067827-000	STEERING VALVE BRACKET	1
16	025427-002	HANDLE	1
17	026533-002	RIVET POP, 3/16D .126 -.250 GRIP	4
18	067856-000	STIFFENER BAR	1
19	011708-004	SCREW RD HD 8-32 X 1/2	4
20	011248-002	NUT HEX 8-32 ESNA	4
21	011254-006	SCREW HHC 3/8-16 X 3/4	2
22	064039-001	HYDRAULIC TANK MOUNTING TAB	1
23	067624-000	HYDRAULIC FILTER	1
*	067624-010	ELEMENT, FILTER	1
24	011916-011	ELBOW 90° 20FP-20FP (1-1/4 NPT)	1
25	067854-000	ANGLE RES. MOUNT	1
26	011240-006	WASHER 3/8 FLAT STD	26
27	011254-008	SCREW HHC 3/8-16 X 1	12
28	011248-006	NUT HEX 3/8-16 ESNA	14
29	063650-012	SPRING, PRESSURIZED GAS	1
30	067648-008	END FITTING, GAS SPRING	REF
31	015936-004	SCREW SHOULDER 3/8Ø X 1/2	2
32	014902-005	FITTING TEE 12MP-12FP	1

ITEM	PART	DESCRIPTION	QTY.
33	011939-030	FITTING 20MP-20MJ	1
34	011923-008	FITTING 12MP-6FP	1
35	011940-008	FITTING 90° 6MP-4MJ	1
36	067898-000	RADIATOR COVER	1
37	063930-001	BREATHER/FILLER CAP	1
38	021305-007	PLUG, MAGNETIC	1
39	067696-001	EXHAUST TUBE, DIESEL	1
40	067902-000	BRACKET, GAS SPRING	1
41	010070-099	SEAL STRIP GASKET	FT1.82
42	067691-000	SNORKEL WELDMENT, DIESEL	1
43	013259-008	MUFFLER CLAMP 2"	1
44	067697-001	BREATHER SPACER (DIESEL) (RADIATOR)	1
45	011252-008	SCREW HHC 1/4-20 X 1	10
46	011240-004	WASHER FLAT STD 1/4	10
47	064462-023	PLUG, 3/8 CAP	2
48	013259-006	CLAMP, MUFFLER 1-1/2"	2
49	063979-006	CAGE, LUBE SIGHT	1
50	011248-004	NUT HEX ESNA 1/4-20	6
51	066697-099	PIPE INSULATION 1-3/8ØØ	1
52	011248-005	NUT HEX 5/16-18 ESNA	2
53	011253-007	SCREW HHC 5/16-18 X 7/8	4
54	011240-005	WASHER 5/16 FLAT STD	4
55	011238-005	WASHER LOCK 5/16	4
56	011250-005	NUT HEX 5/16-18	4
57	011923-007	FITTING 12MP-4FP	1
58	011940-004	FITTING 90°4MP-4MJ	1
59	011939-013	FITTING 8MP-4MJ	1
60	011939-015	FITTING 8MP-8MJ	1
61	011939-014	FITTING 8MP-6MJ	1
62	063936-024	MUFFLER GASKET	1
63	067765-000	TUBE EXTENSION	1
64	011253-008	SCREW HHC 5/16-18 X 1	2
65	011248-005	NUT 5/16-18 ESNA	2

# Illustrated Parts Breakdown

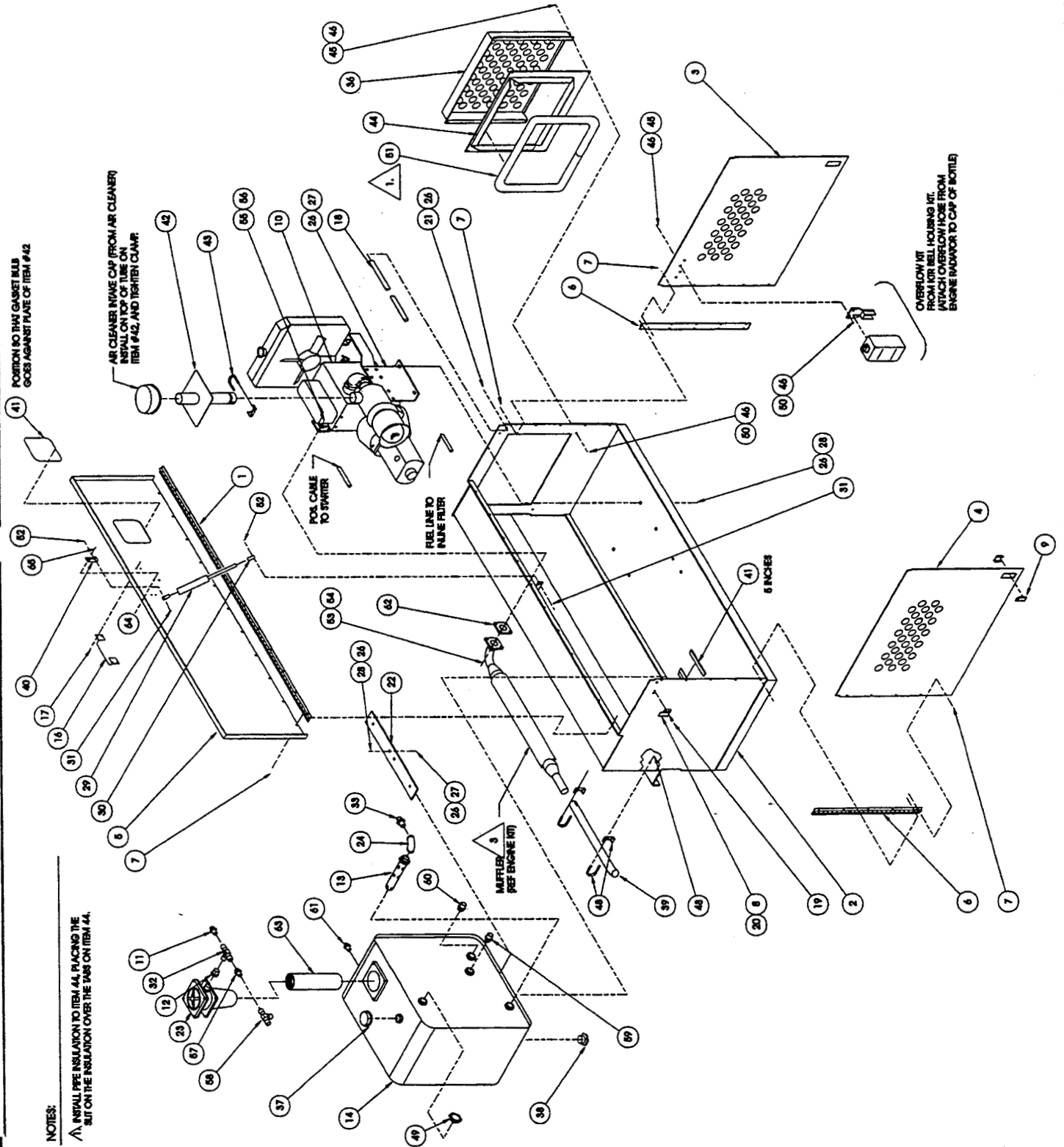

ENGINE ASSEMBLY, L50  
KUBOTA GAS  
067523-001

ITEM	PART	DESCRIPTION	QTY.
1	067615-000	ENGINE, KUBOTA GAS	1
2	067608-000	PUMP, VARIABLE DISPLACEMENT	1
3	063941-000	SOLENOID, CHOKE	1
4	012733-099	HOSE, FUEL LINE Ø 5/16	FT9
5	020541-001	HOSE CLAMP	6
6	REF	FUEL FILTER, INLINE	1
7	027972-000	SOLENOID, STARTER RELAY	1
8	011252-006	SCREW HHC 1/4-20 X 3/4	14
9	067874-000	BRACKET, ENGINE MOUNT GAS	2
10	067615-042	ENGINE ACCESSORY KIT	1
11	067872-000	BRACKET, AIR CLEANER	1
12	011254-008	SCREW HHC 3/8-16 X 1	2
13	064177-004	WELDMENT, MUFFLER SPACER	1
14	REF	COIL, IGNITION	1
15	067599-000	SOLENOID THROTTLE	1
18	011935-004	FITTING 8MBH-8MJ 45°	1
19	067871-000	BRACKET, SOLENOID	1
20	011254-010	SCREW HHC 3/8-16UNC X 1-1/4	4
21	011238-006	LOCKWASHER, SPLIT 3/8	6
22	067670-012	SPLIT FLANGE - HALF 3/4	2
23	067671-012	"O"-RING	1
24	067671-020	"O"-RING	1
25	014338-008	FITTING SPLIT FLANGE - 20MJ 90°	1
26	067670-020	SPLIT FLANGE - 1-1/4	2
27	011255-010	SCREW HHC 7/16-14UNC X 1-1/4	4
28	011238-007	LOCK WASHER SPLIT 7/16	4
30	011252-008	SCREW HHC 1/4-20UNC X 1	2
31	011240-004	WASHER FLAT STD 1/4	10
32	011238-004	WASHER SPLIT LOCK 1/2	2
33	011248-004	NUT HEX 1/4-20 ESNA	14
34	067617-020	KTR BELL HOUSING KIT D/F #0034	1
35	011256-010	SCREW HHC 1/2-13UNC X 1-1/4	2
36	011941-001	FITTING STR 4MB-4MJ	1
37	064183-000	SPACER, ENGINE	2
38	011937-001	FITTING 90° 4FJ-4MJ	1

ITEM	PART	DESCRIPTION	QTY.
39	011240-006	WASHER FLAT STD 3/8	2
40	063946-030	SCREW HHC M10 X 1.25 GR5 X 30MM	14
41	REF	SCREW (SUPPLIED W/ AIR CLEANER)	2
42	REF	SCREW MANIFOLD (SUPPLIED W/ ENGINE)	4
43	011709-004	SCREW RD HD 10-24UNC X 1/2	2
44	011248-003	NUT HEX ESNA 10-24UNC	2
46	REF	ELECTRIC FUEL PUMP	1
47	011261-004	SCREW HHC 1/4-28 UNF	2
48	030624-019	CHOKE ANGLE	1
49	030624-020	CHOKE ROD	1
50	030624-008	CHOKE SOLENOID BRACKET	1
51	011240-007	WASHER FLAT STD 7/16	12
52	014338-002	FITTING 12FL-12MJ 90°	1
53	003142-001	FITTING 2MP-2FP	1
54	063945-001	OIL PRESS SWITCH	1
55	067807-000	SOLENOID BRACKET	1
56	020495-004	NUT HEX JAM 1/4-28UNF	1
57	011847-004	YOKE END	1
58	020731-005	CHAIN 5 LINKS	1
59	068630-006	SPRING LINKAGE	1
102	29601-021	CONN RING 12-10 GA. 5/16D	4
103	29601-014	CONN RING 16-14 GA. 1/4D	6
104	29610-002	CONN FORK 16-14 GA. #8	6
105	29616-002	CONN FEMALE PUSH 16-14 GA. 1/4	2
106	29454-099	WIRE 16 AWG RED	FT. 2
108	29942-099	TUBING HEAT SHRINK 1/4"	FT1
109	29480-099	WIRE 10 AWG RED	FT.
110	29601-039	CONN RING 10-12 GA 5/16 D	4
111	29479-099	WIRE 16 AWG WHT/BLK	FT4
112	29470-099	WIRE 12 AWG RED	FT8
113	29472-099	WIRE 12 AWG BLK	FT3
114	29456-099	WIRE 16 AWG YEL	FT2.5
115	63574-099	WIRE 16 AWG BLK/WHT	FT3

# Illustrated Parts Breakdown

Section  
7.2

## ENGINE REPAIR PARTS

TOYOTA GAS

067523-001

ITEM	PART	DESCRIPTION	QTY.
*	067615-095	DISTRIBUTOR	1
*	067615-026	TRIGGER/IGNITOR	1
*	067615-025	ROTOR	1
*	067615-096	DIST/HOUSING	1
*	064505-002	SPARK PLUG	1
*	067615-020	SPARK PLUG WIRE #1	1
*	067615-021	SPARK PLUG WIRE #2	1
*	067615-022	SPARK PLUG WIRE #3	1
*	067615-082	IGNITION SWITCH	1
*	067615-093	KEY, SWITCH	1
*	067615-027	COIL	1
*	067615-023	COIL WIRE	1
*	067615-028	ALTERNATOR 12V-30 AMP	1
*	067615-094	REGULATOR 12V-30 AMP	1
*	067615-030	STARTER-12V	1
*	067615-097	MAGNETIC SWITCH	1
*	067615-098	OVER-RUNNING CLUTCH	1
*	067615-099	INTAKE MANIFOLD	1
*	067615-100	INTAKE MANIFOLD O-RING	1
*	067615-101	INTAKE MANIFOLD O-RING	1
*	067615-102	INTAKE MANIFOLD CAP SCREW	1
*	067615-103	INTAKE MANIFOLD CAP SCREW	1
*	067615-104	INTAKE MANIFOLD CAP SCREW	1
*	067615-105	INTAKE MANIFOLD O-RING	1
*	067615-106	A/C TO CARB ADAPTER HOSE	1
*	067615-107	AIR CLEANER ASSEMBLY	1
*	064505-008	AIR CLEANER ELEMENT	1
*	067615-108	AIR CLEANER GASKET	1
*	067615-035	EXHAUST MANIFOLD	1
*	067615-109	PIPE (HOSE) INLET	1
*	067615-110	MANIFOLD GASKETS	1
*	067615-111	MANIFOLD STUDS	1
*	067615-112	MANIFOLD NUTS	1
*	067615-113	MUFFLER GASKET	1
*	067615-114	MUFFLER MANIFOLD STUDS	1
*	067615-115	MUFFLER MANIFOLD NUTS	1
*	067615-018	MUFFLER	1
*	067615-013	RADIATOR	1
*	067615-014	RADIATOR CAP	1
*	067615-116	DRAIN COCK	1
*	067615-017	COOLING FAN	1

ITEM	PART	DESCRIPTION	QTY.
*	067615-015	WATER PUMP W/GASKET	1
*	067615-016	THERMOSTAT	1
*	067615-118	THERMOSTAT GASKET	1
*	067615-019	FAN BELT	1
*	067615-017	OVERFLOW TANK KIT	1
*	067615-119	THERMOSTAT HOUSING	1
*	067615-120	LOWER WATER PIPE	1
*	064505-037	DRAIN COCK	1
*	067615-038	DRAIN PLUG O-RING	1
*	067615-039	CYL HEAD GASKET	1
*	067615-044	HEAD COVER GASKET	1
*	067615-045	BREATHER ELEMENT	1
*	067615-079	FLYWHEEL	1
*	067615-080	RING GEAR	1
*	067615-041	KTR HUB 6-13-15	1
*	067615-042	KTR NYLON GEAR 9T	1
*	064505-011	OIL FILTER CARTRIDGE	1
*	064505-005	OIL PRESS SWITCH	1
*	067615-083	DIP STICK OIL GAUGE	1
*	067615-084	OIL FILL CAP SEAL	1
*	067615-085	GOVERNOR SPRING-LARGE	1
*	067615-086	SPRING-BUFFER	1
*	067615-087	CONTROL ASSEMBLY PLATE	1
*	067615-088	SPEED CONTROL LEVER	1
*	067614-007	IN-LINE FUEL FILTER	1
*	067615-089	ELECTRIC FUEL PUMP	1
*	064505-090	CARB FLANGE GASKET	1
*	064505-007	CARBURETOR	1
*	067615-012	FUEL OFF SOLENOID	1
*	067615-091	CARB INLET FLANGE	1
*	067615-092	CARB FLANGE SPACER	1
*	067615-078	CARB ADAPTER	1
*	067615-055	LP REG/VAP/CONT	1
*	067615-051	GASOLINE SHUT-OFF	1
*	067615-052	LP LOCK OFF	
*	067615-077	LPG LOAD BLOCK	1
*	067615-070	TANK CPL, 7141F	1
*	067615-075	HYDRASTATIC VALVE	1
*	067615-010	LPG KIT	1
*	067615-121	DISTRIBUTOR CAP	1
*	067615-007	WG750 ENGINE SERVICE MANUAL	1

\* Not Shown

# Illustrated Parts Breakdown

**ENGINE ASSEMBLY**  
**KUBOTA GAS**  
DRAWING 1 OF 2

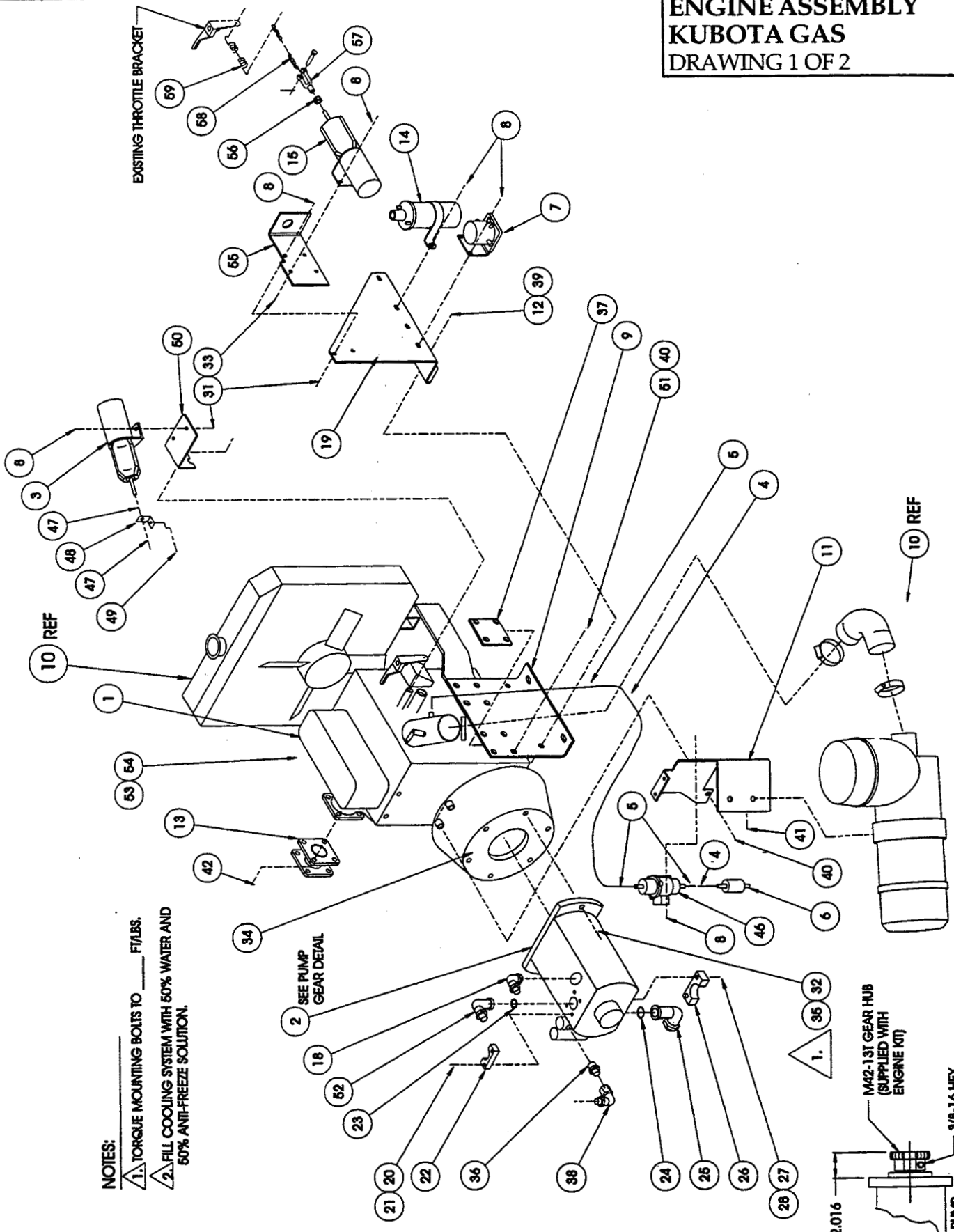

**NOTES:**

- 1. TORQUE MOUNTING BOLTS TO \_\_\_\_ FT/LBS.
- 2. FILL COOLING SYSTEM WITH 50% WATER AND 50% ANTI-FREEZE SOLUTION.

2 SEE PUMP GEAR DETAIL

1. M42-13T GEAR HUB (SUPPLIED WITH ENGINE KIT)

3/8-16 HEX TORQUE TO 46 LB/FT

PUMP GEAR DETAIL

2.016

PUMP

# Illustrated Parts Breakdown

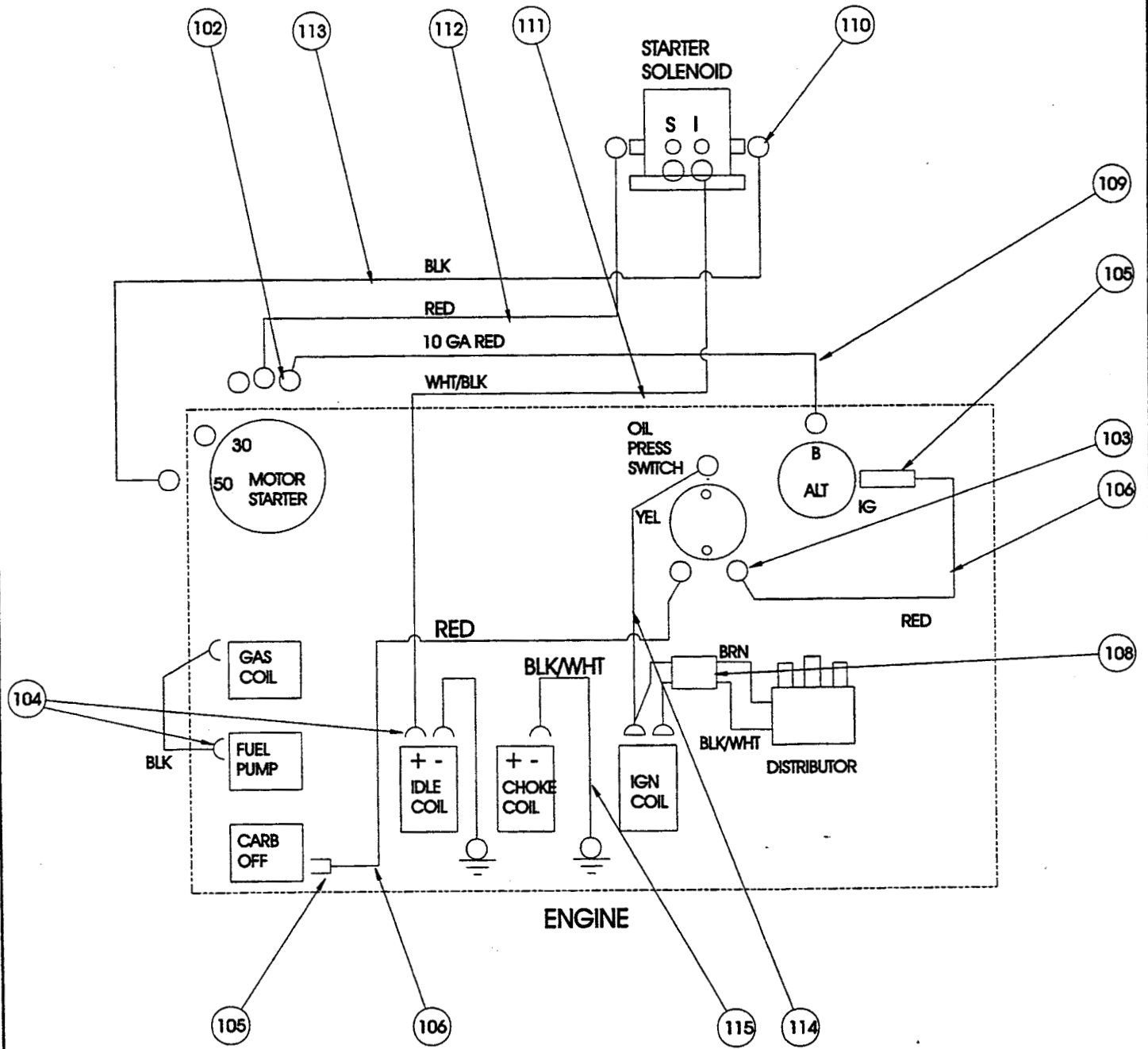

**ENGINE ASSEMBLY**  
**KUBOTA GAS**  
DRAWING 2 OF 2

## ENGINE ASSEMBLY, LX50

KUBOTA DIESEL

067523-002

ITEM	PART	DESCRIPTION	QTY.
1	067614-000	ENGINE, KUBOTA DIESEL	1
*	067614-004	OIL FILTER ELEMENT	1
*	067614-026	FUEL PUMP, LIFT	1
*	067614-009	INJECTION PUMP	1
*	067614-010	INJECTOR NOZZLE	3
*	067614-011	GLOW PLUG	3
*	067614-012	RADIATOR	1
*	067614-013	RADIATOR CAP	1
*	067614-014	THERMOSTAT	1
*	067614-015	WATER PUMP	1
*	067614-018	FAN BELT	1
*	067614-019	ALTERNATOR	1
*	067614-020	VOLTAGE REGULATOR	1
*	067614-022	STARTER	1
*	067614-023	OIL PRESSURE SWITCH	1
*	067614-075	FUEL SHUT OFF SOLENOID	1
*	067614-025	KUBOTA D905 ENGINE SERVICE MANUAL	1
2	067608-000	PUMP, VARIABLE DISPLACEMENT	1
3	067599-000	SOLENOID, THROTTLE	1
4	012733-099	HOSE, FUEL LINE Ø 5/16	FT10
5	020541-001	HOSE CLAMP	6
6	067614-007	FUEL FILTER, INLINE	1
9	064180-001	ENGINE MOUNT BRACKET	2
10	REF	FUEL FILTER MOUNT - SPIN ON	1
11	067859-000	BRACKET, AIR CLEANER	1
12	067614-006	FUEL FILTER - SPIN ON	1
13	064177-004	WELDMENT, MUFFLER SPACER	1
14	067850-000	BRACKET, SOLENOID/GLOW	1
15	067870-000	BRACKET, DIESEL FUEL FILTER	1
16	064423-000	INLINE SWIVEL - 1/4	1
17	011760-004	ROD END BEARING - 1/4-28	1
18	011935-004	FITTING 8MBH-8MJ 45°	1
19	014338-002	FITTING SPLIT FLANGE - 12MJ 90°	1
20	011254-010	SCREW HHC 3/8-16UNC X 1-1/4	4

ITEM	PART	DESCRIPTION	QTY.
21	011238-006	LOCKWASHER, SPLIT 3/8	6
22	067670-012	SPLIT FLANGE - HALF 3/4	2
23	067671-012	"O"-RING	1
24	067671-020	"O"-RING	1
25	014338-008	FITTING SPLIT FLANGE - 20MJ 90°	1
26	067670-020	SPLIT FLANGE - 1-1/4	2
27	011255-010	SCREW HHC 7/16-14UNC X 1-1/4	4
28	011238-007	LOCK WASHER SPLIT 7/16	4
29	011252-004	SCREW HHC 1/4-20UNC X 1/2	2
30	011252-008	SCREW HHC 1/4-20UNC X 1	3
31	011240-004	WASHER FLAT STD 1/4	2
32	011238-004	WASHER SPLIT LOCK 1/2	2
33	011248-004	NUT HEX 1/4 ESNA	7
34	067617-000	KTR BELL HOUSING KIT	1
35	011256-010	SCREW HHC 1/2-13UNC X 1-1/4	2
36	011941-001	FITTING STR 4MB-4MJ	1
37	064183-000	SPACER, ENGINE	2
38	011937-001	FITTING 90° 4FJ-4MJ	1
39	011240-006	WASHER FLAT STD 3/8	2
40	063946-030	SCREW HHC M10 X 1.25 GR5 X 30MM	12
41	REF	SCREW (SUPPLIED W/ AIR CLEANER)	2
42	REF	SCREW MANIFOLD (SUPPLIED W/ ENGINE)	4
43	003142-001	ADAPTER, 2MP-2FP	1
44	063945-001	OIL PRESSURE SWITCH	1
45	067672-010	SCREW HHC M8 X 1.25 X 10MM	REF
46	011240-007	WASHER FLAT STD 7/16	12
101	029931-003	CONN FEM. PUSH 14-16GA. .25	5
102	029601-040	CONN RING 14-16GA. 5/16D	6
103	029601-020	CONN RING 12-10GA. 1/4D	2
104	029601-039	CONN RING 12-10GA. 5/16D	3
105	029601-014	CONN RING 16-14GA. 1/4D	2
107	029452-099	WIRE 16AWG COPPER -BLACK	FT4
108	029480-099	WIRE 10AWG COPPER -RED	FT2
109	029454-099	WIRE 16AWG COPPER -RED	FT8
110	029451-099	WIRE 16AWG COPPER -WHITE	FT2

\* Not Shown

UP TO SERIAL NUMBER 2218

# Illustrated Parts Breakdown

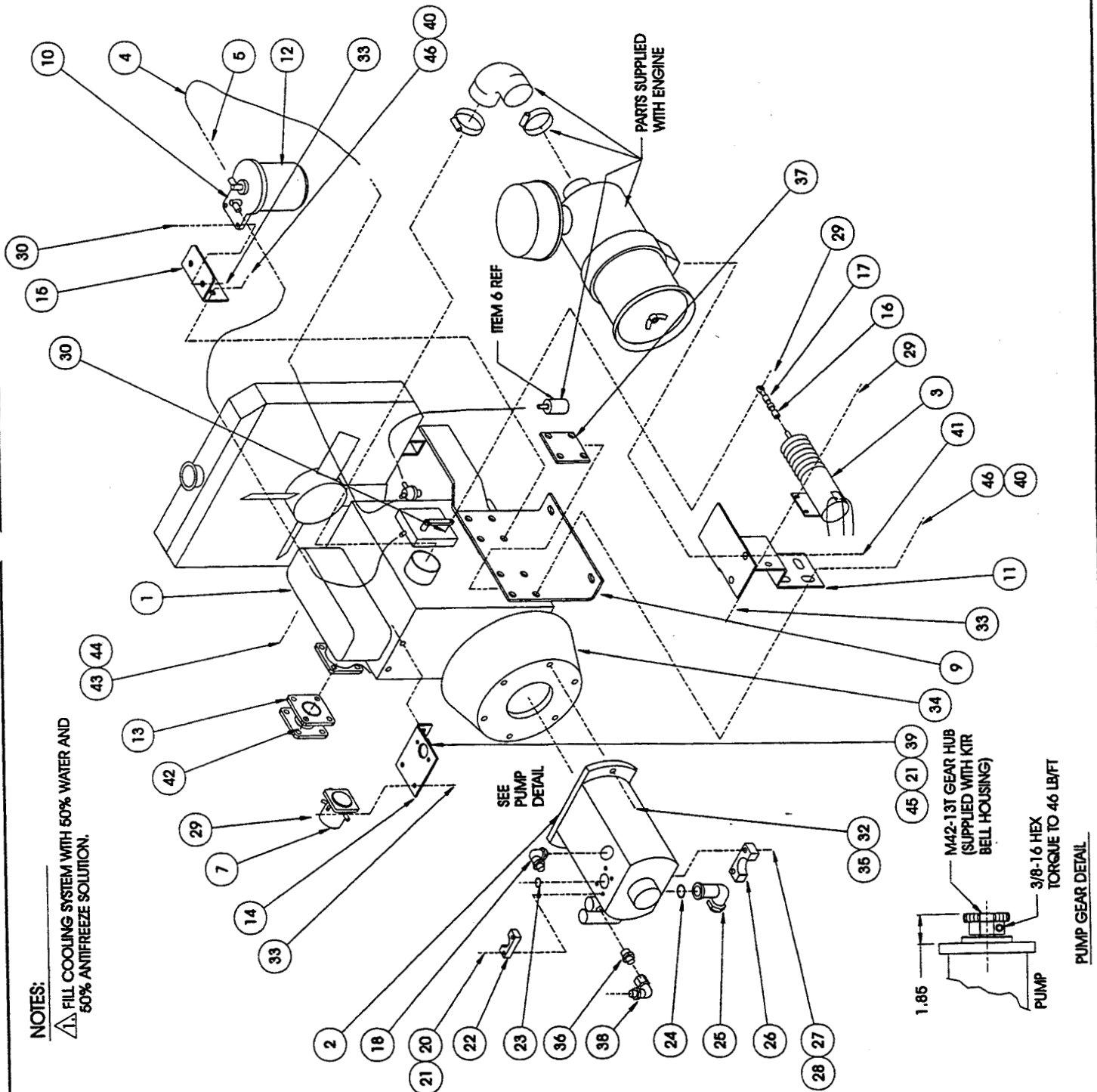

**NOTES:**

▲ FILL COOLING SYSTEM WITH 50% WATER AND 50% ANTIFREEZE SOLUTION.

UP TO SERIAL NUMBER 2218

**ENGINE ASSEMBLY**  
**KUBOTA DIESEL**  
DRAWING 1 OF 2



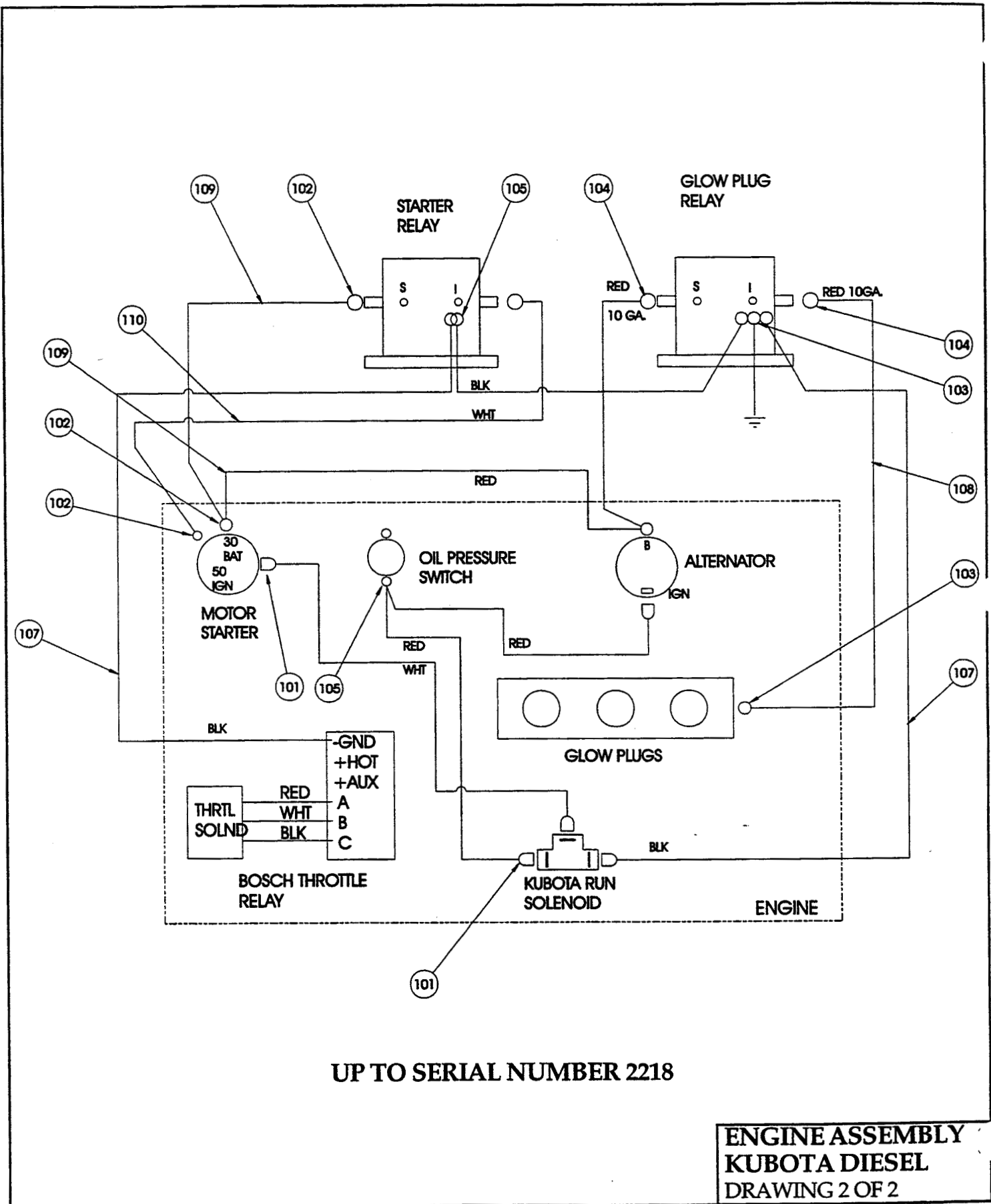

NOTES:

## ENGINE ASSEMBLY, LX50

KUBOTA DIESEL

067523-002

ITEM	PART	DESCRIPTION	QTY.
1	067614-000	ENGINE, KUBOTA DIESEL	1
2	067608-000	PUMP, VARIABLE DISPLACEMENT	1
3	067599-000	SOLENOID, THROTTLE	1
4	012733-099	HOSE, FUEL LINE Ø 5/16	FT10
5	020541-001	HOSE CLAMP	6
6	067614-007	FUEL FILTER, INLINE	1
7	027972-000	SOLENOID, STARTER RELAY	1
9	064180-001	ENGINE MOUNT BRACKET	2
10	REF	FUEL FILTER MOUNT - SPIN ON	1
11	067859-000	BRACKET, AIR CLEANER	1
12	067614-006	FUEL FILTER - SPIN ON	1
13	064177-004	WELDMENT, MUFFLER SPACER	1
14	067850-000	BRACKET, SOLENOID/GLOW	1
15	067870-000	BRACKET, DIESEL FUEL FILTER	1
16	064423-000	INLINE SWIVEL - 1/4	1
17	011760-004	ROD END BEARING - 1/4-28	1
18	011935-004	FITTING 8MBH-8MJ 45°	1
19	014338-002	FITTING SPLIT FLANGE - 12MJ 90°	1
20	011254-010	SCREW HHC 3/8-16UNC X 1-1/4	4
21	011238-006	LOCKWASHER, SPLIT 3/8	6
22	067670-012	SPLIT FLANGE - HALF 3/4	2
23	067671-012	"O"-RING	1
24	067671-020	"O"-RING	1
25	014338-008	FITTING SPLIT FLANGE - 20MJ 90°	1
26	67670-020	SPLIT FLANGE - 1-1/4	2
27	011255-010	SCREW HHC 7/16-14UNC X 1-1/4	4
28	011238-007	LOCK WASHER SPLIT 7/16	4
29	011252-004	SCREW HHC 1/4-20UNC X 1/2	2
30	011252-008	SCREW HHC 1/4-20UNC X 1	3

ITEM	PART	DESCRIPTION	QTY.
31	011240-004	WASHER FLAT STD 1/4	2
32	011238-004	WASHER SPLIT LOCK 1/2	2
33	011248-004	NUT HEX 1/4 ESNA	7
34	067617-000	KTR BELL HOUSING KIT	1
35	011256-010	SCREW HHC 1/2-13UNC X 1-1/4	2
36	011941-001	FITTING STR 4MB-4MJ	1
37	064183-000	SPACER, ENGINE	2
38	011937-001	FITTING 90° 4FJ-4MJ	1
39	011240-006	WASHER FLAT STD 3/8	2
40	063946-030	SCREW HHC M10 X 1.25 GR5 X 30MM	12
41	REF	SCREW (SUPPLIED W/ AIR CLEANER)	2
42	REF	SCREW MANIFOLD (SUPPLIED W/ ENGINE)	4
43	003142-001	ADAPTER, 2MP-2FP	1
44	063945-001	OIL PRESSURE SWITCH	1
45	067672-010	SCREW HHC M8 X 1.25 X 10MM	REF
46	011240-007	WASHER FLAT STD 7/16	12
101	029931-003	CONN FEM. PUSH 16-14 GA. .25	6
102	029601-040	CONN RING 14-16GA. 5/16D	6
103	029601-020	CONN RING 12-10GA. 1/4D	2
104	029601-039	CONN RING 12-10GA. 5/16D	3
105	029601-014	CONN RING 16-14GA. 1/4D	2
106	029617-002	CONN MALE PUSH 16-14 GA. 1/4	1
107	029452-099	WIRE 16AWG COPPER -BLACK	FT4
108	029480-099	WIRE 10AWG COPPER -RED	FT2
109	029454-099	WIRE 16AWG COPPER -RED	FT8
110	029451-099	WIRE 16AWG COPPER -WHITE	FT2

SERIAL NUMBER 2219 TO CURRENT

# Illustrated Parts Breakdown

Section  
7.2

## ENGINE REPAIR PARTS

KUBOTA DIESEL

067523-002

ITEM	PART	DESCRIPTION	QTY.
*	067615-037	DRAIN COCK	1
*	067614-036	PAN GASKET	1
*	067614-037	DRAIN PLUG O-RING	1
*	067614-038	CYL HEAD GASKET	1
*	067614-039	HEAD COVER GASKET	1
*	067614-040	BREATHER ELEMENT	1
*	067614-032	FLY WHEEL	1
*	067614-031	RING GEAR	1
*	067617-051	KTR HUB 6-13-15	1
*	067617-052	KTR NYLON GEAR 9T	1
*	067614-004	OIL FILTER CARTRIDGE	1
*	067614-023	OIL PRESS SWITCH	1
*	067614-041	DIP STICK OIL GAUGE	1
*	067615-084	OIL FILL CAP SEAL	1
*	067614-042	GOVENOR SPRING-LARGE	1
*	067614-043	GOVENOR SPRING-START	1
*	067614-009	FUEL INJECTION PUMP	1
*	067614-044	SHIM ASSEMBLY	1
*	067614-045	SHIM ASSEMBLY	1
*	067614-046	CONTROL PLATE ASSEMBLY	1
*	067614-047	SPEED CONTROL LEVER	1
*	067614-048	STOP LEVER	1
*	067614-049	NOZZLE HOLDER ASSEMBLY	1
*	067614-050	NOZZLE HOLDER GASKET	1
*	067614-051	PLEATED FUEL ELEMENT	1
*	067614-052	FUEL FILTER ASSEMBLY	1
*	067614-053	O-RING FILTER-SMALL	1
*	067614-054	SPIN ON ELEMENT	1
*	067614-026	MECHANICAL FUEL PUMP	1
*	067614-016	OVERFLOW TANK KIT	1
*	068694-019	THERMOSTAT HOUSING	1
*	067614-075	SHUT DOWN SOLENOID	1

\* Not Shown

ITEM	PART	DESCRIPTION	QTY.
*	067614-055	AIR BLEEDER SCREW	1
*	067615-082	IGNITION SWITCH	1
*	067615-093	KEY, SWITCH	1
*	067614-011	GLOW PLUGS	1
*	067614-056	GLOW PLUG CORD	1
*	067614-057	ALTERATOR, 12V-40AMP	1
*	067614-058	ALTERNATOR STAY	1
*	067614-059	STARTER-12V	1
*	067614-060	MAGNETIC SWITCH	1
*	067614-061	OVER RUNNING CLUTCH	1
*	067614-062	INTAKE MANIFOLD	1
*	067614-063	INTAKE MANIFOLD O-RING	1
*	067614-064	INTAKE MANIFOLD CAP SCREW	1
*	067614-065	INTAKE MANIFOLD CAP SCREW	1
*	067614-066	INTAKE MANIFOLD CAP SCREW	1
*	068694-018	AIR CLEANER ASSEMBLY	1
*	064505-008	AIR CLEANER ELEMENT	1
*	067615-108	AIR CLEANER GASKET	1
*	067614-029	EXHAUST MANIFOLD	1
*	067614-067	MANIFOLD GASKETS	1
*	067614-068	MANIFOLD STUDS	1
*	067614-069	MANIFOLD NUTS	1
*	067614-070	MUFFLER GASKET	1
*	068694-017	MUFFLER	1
*	067614-071	MUFFLER MANIFOLD NUTS	1
*	067614-013	RADIATOR CAP	1
*	067614-072	DRAIN COCK	1
*	067614-073	DRAIN COCK GASKET	1
*	067614-030	COOLING FAN	1
*	067614-015	WATER PUMP W/GASKET	1
*	067614-014	THERMOSTAT	1
*	067614-074	THERMOSTAT GASKET	1
*	067614-075	FUEL SHUT OFF SOLENOID	1
*	067614-018	FAN BELT	1
*	067614-025	KUBOTA D905 ENGINE SERVICE MANUAL	1

# Illustrated Parts Breakdown

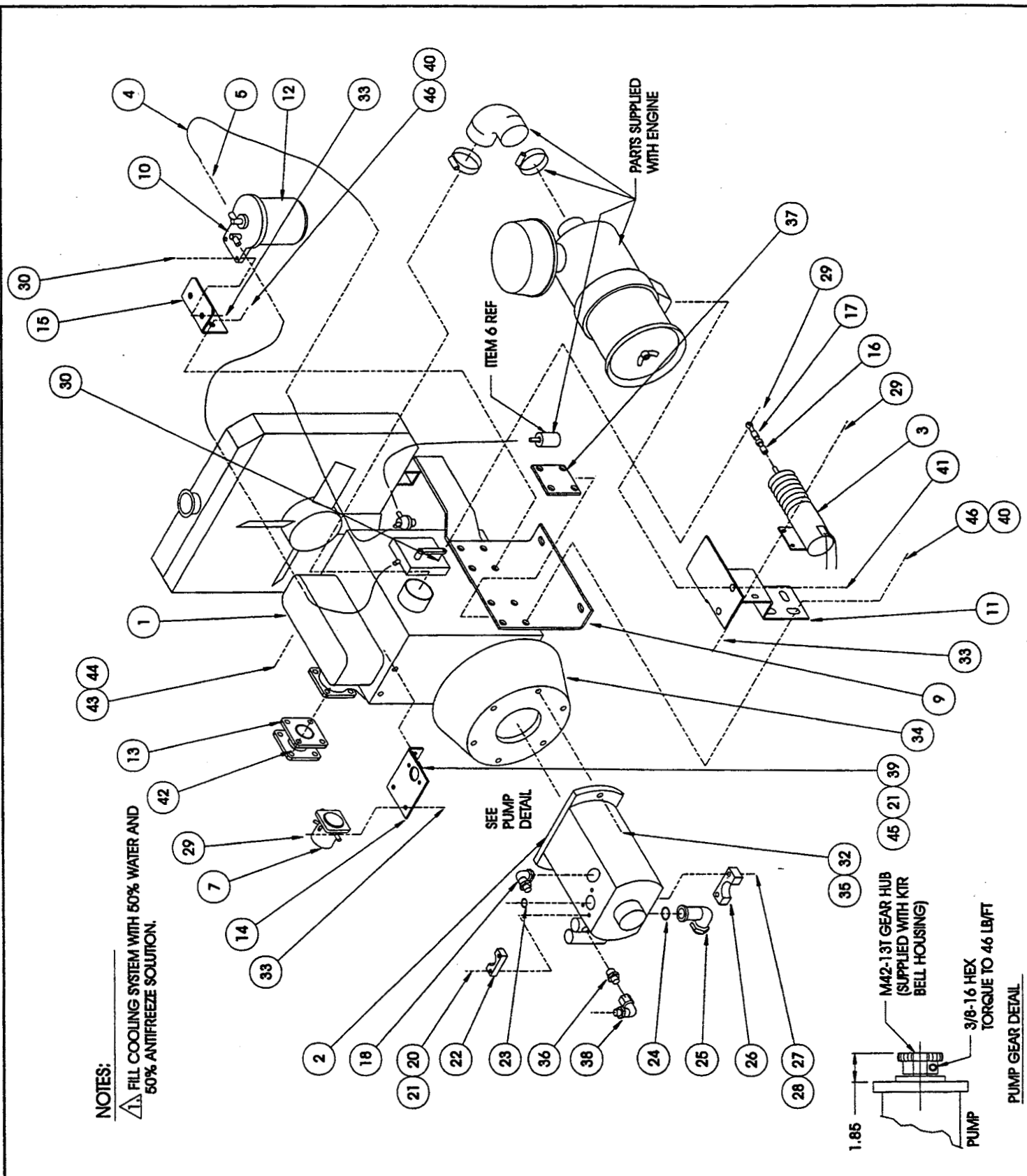

**NOTES:**

▲ FILL COOLING SYSTEM WITH 50% WATER AND 50% ANTIFREEZE SOLUTION.

**SERIAL NUMBER 2219 TO CURRENT**

**ENGINE ASSEMBLY  
KUBOTA DIESEL  
DRAWING 1 OF 2**

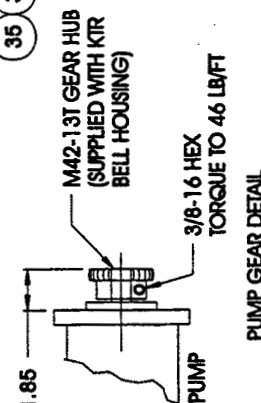

# Illustrated Parts Breakdown

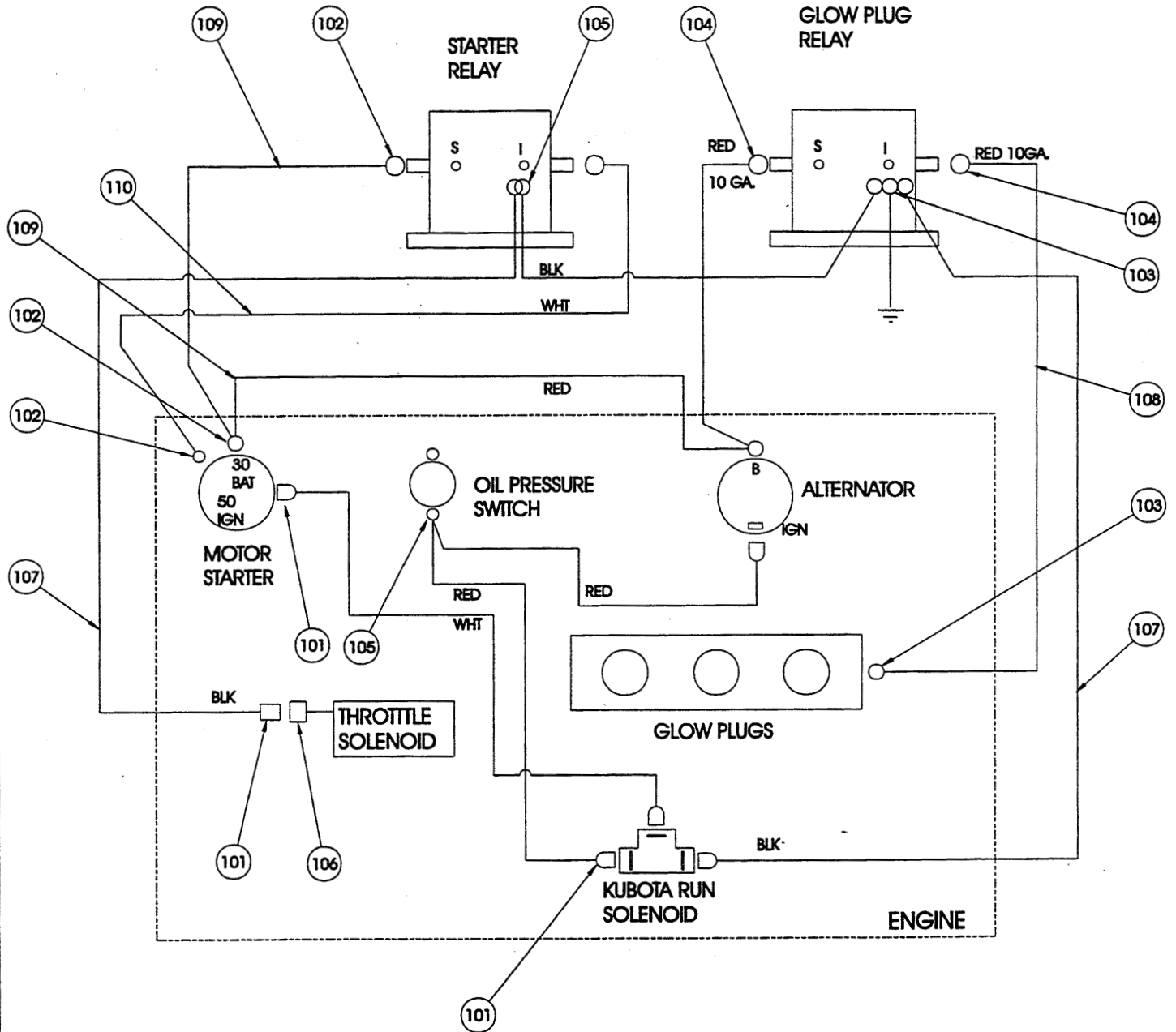

SERIAL NUMBER 2219 TO CURRENT

ENGINE ASSEMBLY  
KUBOTA DIESEL  
DRAWING 2 OF 2

## VALVE BLOCK ASSEMBLY, LX50

Two Wheel Drive

067524-000

ITEM	PART	DESCRIPTION	QTY.
1	067821-000	VALVE BLOCK	1
2	060390-008	VALVE, RELIEF	2
3	063928-001	VALVE, D O 3	1
4	063955-010	PLUG, CAVITY #8 - 2 WAY	1
5	063955-009	PLUG, CAVITY #8 - 3 WAY	1
6	067621-000	VALVE, PROPORTIONAL	1
7	060390-016	VALVE, RELIEF	1
8	067622-000	VALVE, SOL. 2 POS 3 WAY	5
9	014862-003	VALVE, COUNTERBALANCE	2
10	067623-000	VALVE, FLOW DIVIDER/COMBINER	1
11	011941-005	ADAPTER, #6 MB - #6 MJ	2
12	011941-009	ADAPTER, #8 MB - #6 MJ	1
13	011941-015	ADAPTER, #10 MB - #10 MJ	4
14	011941-020	ADAPTER, #12 MB - #12 MJ	2
15	011934-003	ADAPTER, 90° #6 MB - #4 MJ	2
16	015961-004	ADAPTER, TEE #4MB-#4MJ-#4MJ	1

ITEM	PART	DESCRIPTION	QTY.
17	005133-000	SPRING	1
18	015919-000	ORIFICE	1
19	067667-000	ORIFICE .059 DIA. (1.5MM)	1
20	067619-000	STACK PLATE, SHUTTLE VALVE	1
21	063965-001	PLUG, GAUGE PORT	3
22	020021-004	PLUG, #4 MB	1
23	011979-002	O-RING, #2 MB	1
24	011939-000	ADAPTER, #2 MJ - #2 MP	1
25	011929-001	COUPLER, #2 FP - #2 FP	1
26	020733-005	ADAPTER, TEE #12FIX-#12MJ-#12MJ	1
27	013968-005	ADAPTER 90°, #12FIX-#12MP	1
28	067618-004	CHECK VALVE	1
29	014412-022	SCRW SOC HD #10-24UNC X 2-3/4	4
30	020021-010	PLUG #10MB	1
31	014903-011	O-RING	4

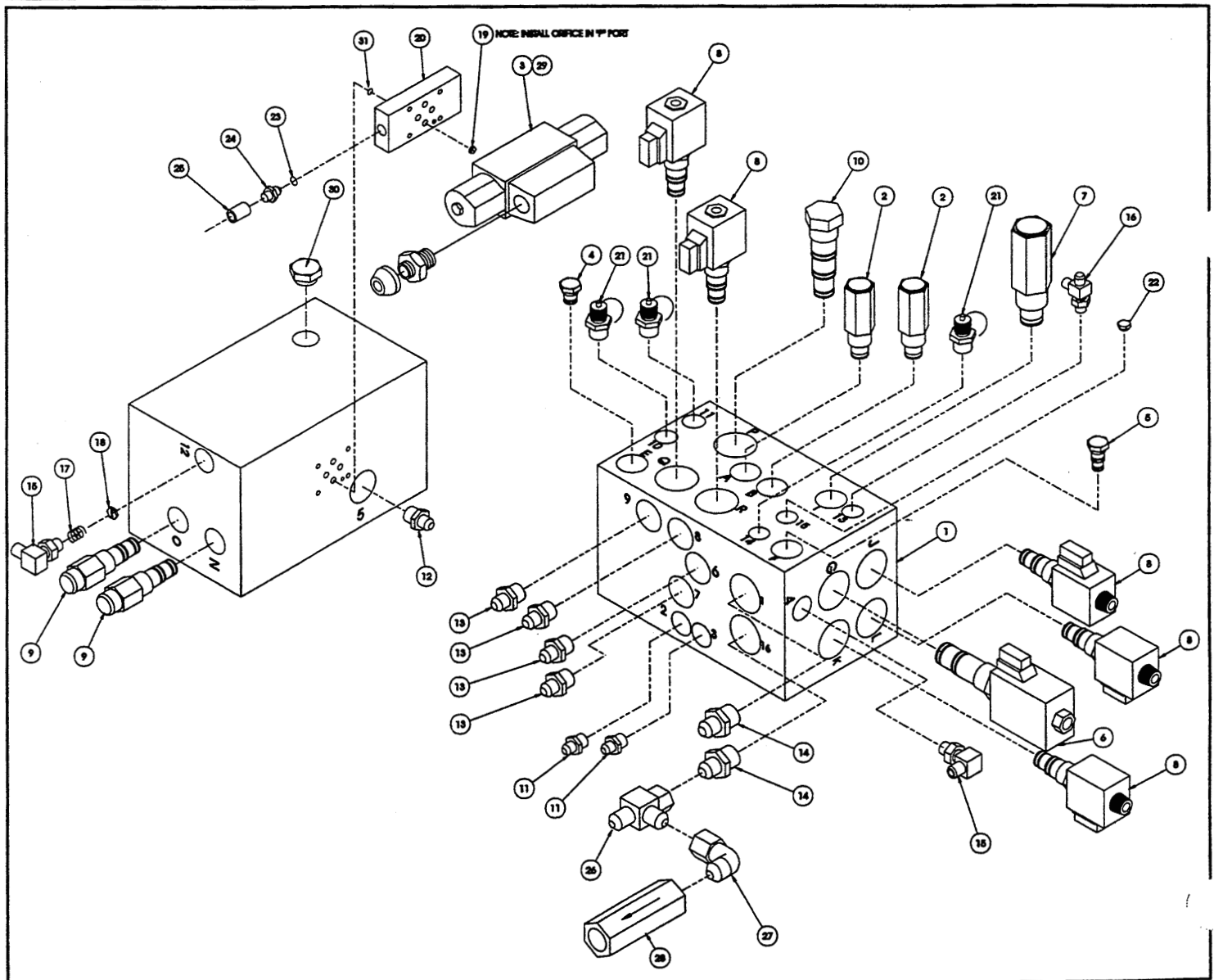

# Illustrated Parts Breakdown

Section  
7.2

## VALVE BLOCK ASSEMBLY, LX50

FOUR WHEEL DRIVE

067524-001

ITEM	PART	DESCRIPTION	QTY.
1	067821-000	VALVE BLOCK	1
2	060390-008	VALVE, RELIEF	2
3	063928-001	VALVE, D O 3 3 POS - 4 WAY	1
4	063355-002	VALVE, WATERMAN 2 WAY N.C.	1
5	067649-000	VALVE, COMPACT 2 POS - 3 WAY	1
6	067621-000	VALVE, PROPORTIONAL	1
7	060390-016	VALVE, RELIEF	1
8	067622-000	VALVE, SOL. 2 POS 3 WAY	5
9	014862-003	VALVE, COUNTERBALANCE	2
10	020021-012	PLUG, #12 MB	1
11	011941-005	ADAPTER, #6 MB - #6 MJ	2
12	011941-009	ADAPTER, #8 MB - #6 MJ	1
13	011941-015	ADAPTER, #10 MB - #10 MJ	4
14	011941-020	ADAPTER, #12 MB - #12 MJ	2
15	011934-003	ADAPTER, 90° #6 MB - #4 MJ	2
16	015961-004	ADAPTER, TEE #4MB-#4MJ-#4MJ	1

ITEM	PART	DESCRIPTION	QTY.
17	005133-000	SPRING	1
18	015919-000	ORIFICE	1
19	067667-000	ORIFICE .059 DIA. (1.5MM)	1
20	067619-000	STACK PLATE, SHUTTLE VALVE	1
21	063965-001	PLUG, GUAGE PORT	3
22	020021-004	PLUG, #4 MB	1
23	011979-002	O-RING, #2 MB	1
24	011939-000	ADAPTER, #2 MJ - #2 MP	1
25	011929-001	COUPLER, Z2 FP - #2 FP	1
26	020733-005	ADAPTER, TEE #12FJX-#12MJ-#12MJ	1
27	013968-005	ADAPTER 90°, #12FJX - #12MP	1
28	067618-004	CHECK VALVE	1
29	014412-022	SCRW SOC HD #10-24UNC X 2-3/4	4
30	020021-010	PLUG #10MB	1
31	014903-011	O-RING	4

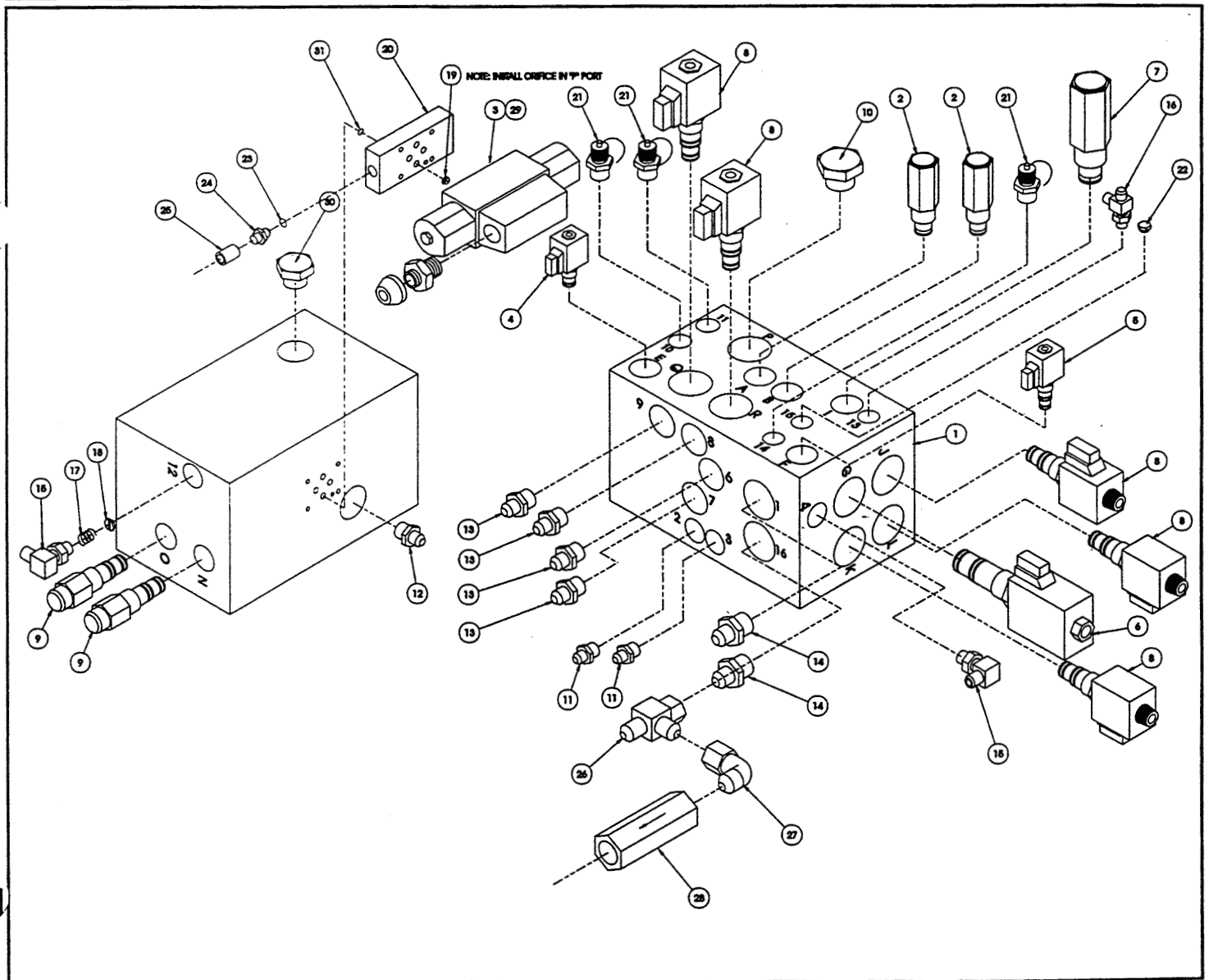



**CONTROL BOX ASSEMBLY, LX50**  
**FOUR WHEEL DRIVE GAS/FOUR WHEEL DRIVE**  
**GAS, DUAL DECK/TWO WHEEL DRIVE GAS**  
 067527-000

ITEM	PART	DESCRIPTION	QTY.
1	067825-000	ENCLOSURE	1
2	067529-000	PANEL ASSEMBLY, DUAL FUEL	1
3	064417-001	MOUNTING LATCH	9
4	064443-001	CONTACT BLOCK, N.O.	8
5	064443-002	CONTACT BLOCK, N.C.	4
6	067652-000	PUSH BUTTON, MOM. FLUSH, GREEN	3
7	067653-000	PUSH BUTTON, MOM. EXT. RED	2
8	067654-000	PUSH BUTTON, MOM. FLUSH, BLK.	1
9	066807-003	DOWN ALARM	1
10	029868-007	CIRCUIT BREAKER, 15 AMP.	2
11	064446-003	PUSH BUTTON, MUSHROOM, RED	1
13	064445-001	SELECTOR SWITCH, 3 POS.	1
14	011252-004	SCRW, HHC 1/4-20UNC X 1/2	2
15	011248-006	NUT, SELF LOCKING, 3/8-16	4
16	014996-006	FLATWASHER, 3/8"	4
17	029925-011	CABLE CONNECTOR, 3/4"	4
18	064462-009	HOLE PLUG, Ø 1 1/16	2
19	029939-003	CONDUIT NUT, 3/4"	4
21	066807-001	ALARM, TILT	1
22	014996-004	WASHER, 1/4 DIA. SAE	2
23	066516-000	PLUG, HOLE ØØ 2.093	1
24	064445-001	SELECTOR SWITCH, 3 POSITION	1
101	029825-002	DIODE 3 AMP	7
102	029610-002	TERMINAL #8 FORK	37
103	029610-003	TERMINAL #6 FORK	32
104	029731-005	RESISTOR, 10 OHM	1
105	029496-099	CABLE 2 COND 16GA	FT22
106	029447-099	CABLE 3 COND 16GA	FT8
107	005491-099	WIRE 16GA GRN/BLK	FT1
108	029450-099	WIRE 16GA BLU	FT8
109	029451-099	WIRE 16GA WHT	FT7
110	029452-099	WIRE 16GA BLK	FT10
111	029456-099	WIRE 16GA YEL	FT2
112	029457-099	WIRE 16GA GRN	FT1
113	029459-099	WIRE 16GA BLU/WHT	FT5
114	029475-099	WIRE 16GA BLU/BLK	FT6
115	029477-099	WIRE 16GA ORN/BLK	FT4
116	029478-099	WIRE 16GA RED/BLK	FT4
117	029482-099	WIRE 16GA GRN/WHT	FT2
118	029483-099	WIRE 16GA RED/WHT	FT2
120	029620-002	CONN 16GA BUTT	2

# Illustrated Parts Breakdown

Section  
7.2

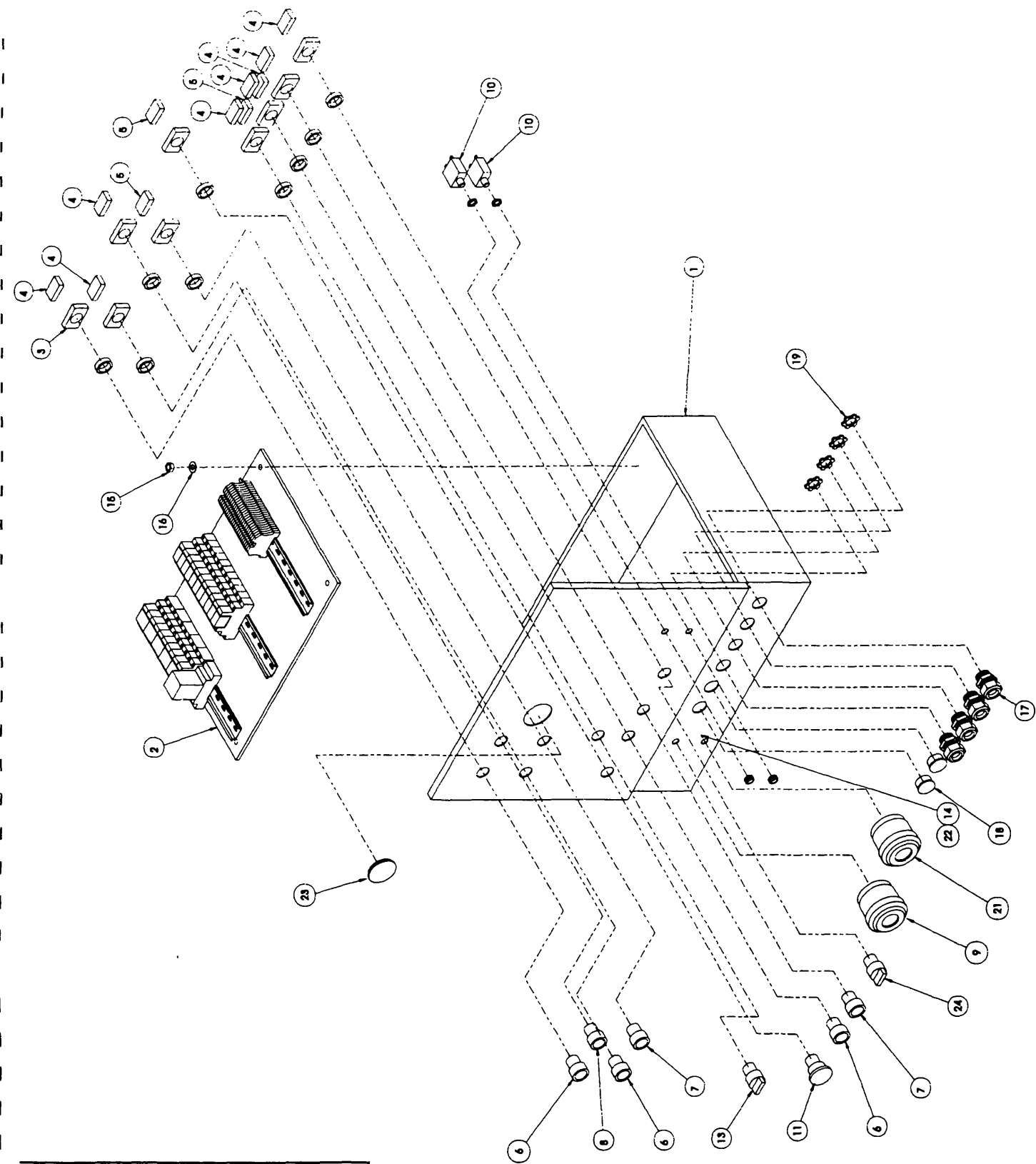

CONTROL BOX ASSEMBLY  
LX50, GAS  
DRAWING 1 OF 3

# Illustrated Parts Breakdown

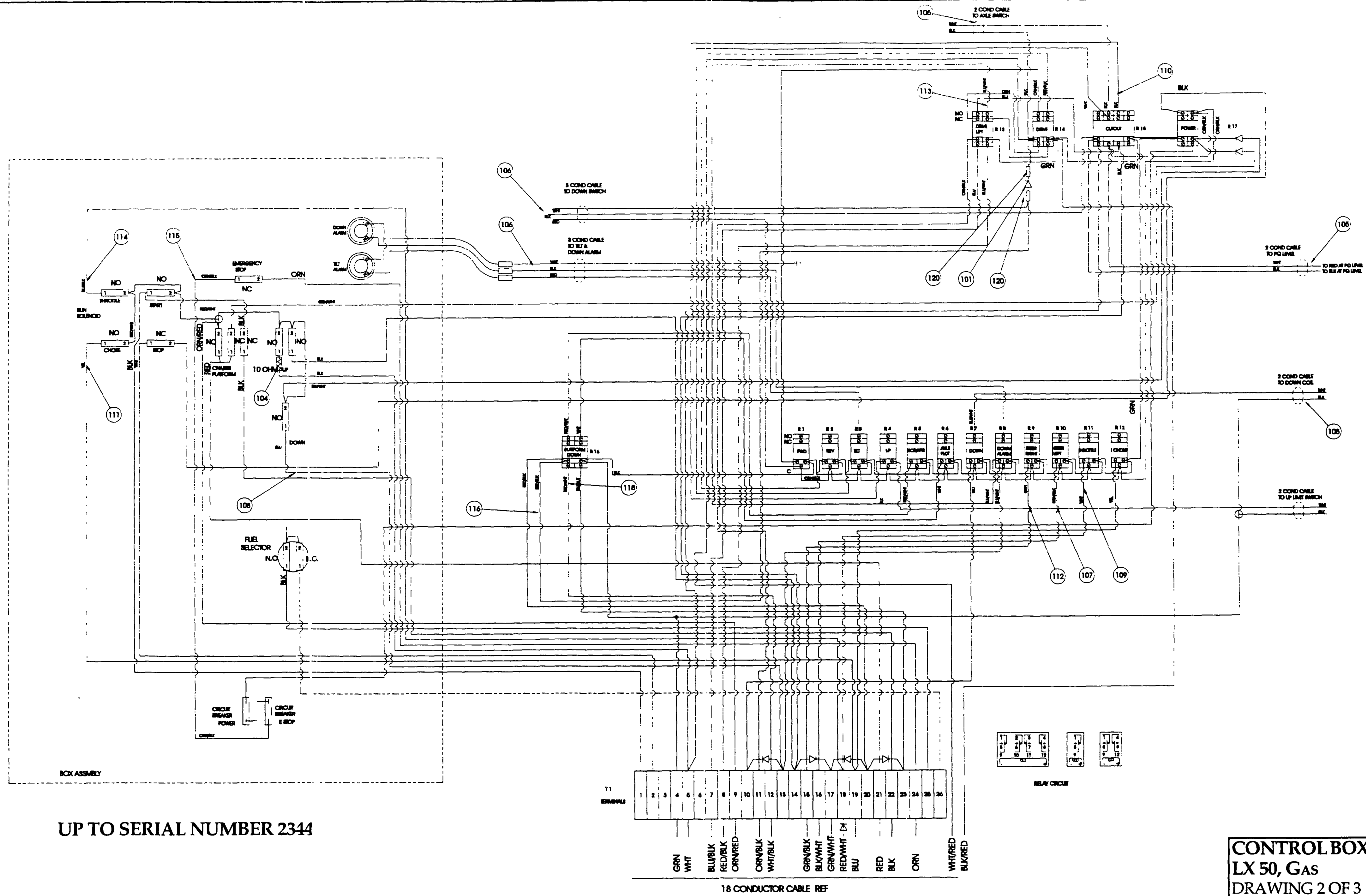

**CONTROL BOX ASSEMBLY**  
**LX 50, GAS**  
**DRAWING 2 OF 3**

# Illustrated Parts Breakdown

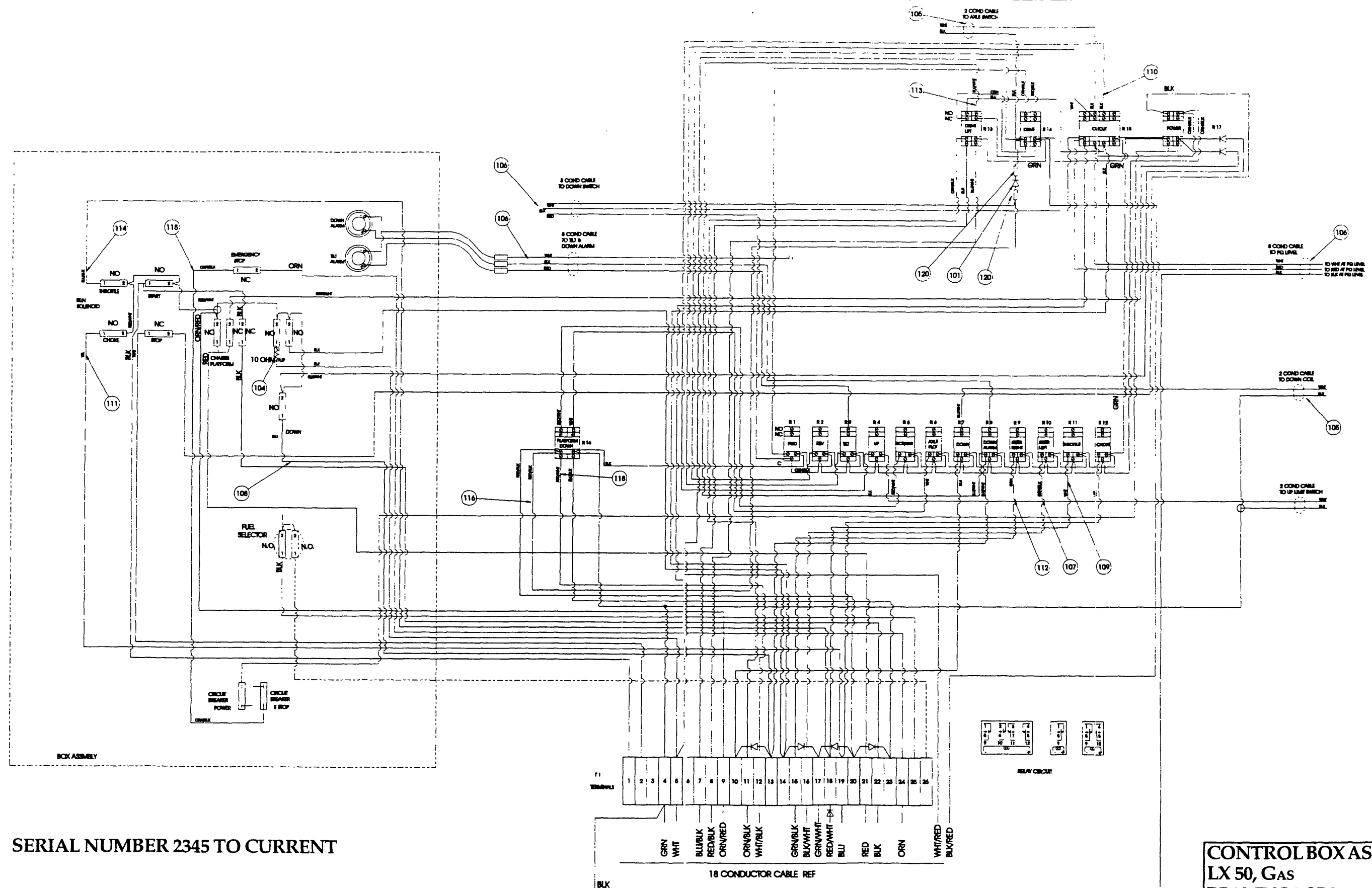

SERIAL NUMBER 2345 TO CURRENT

**CONTROL BOX ASSEMBLY**  
LX 50, Gas  
DRAWING 3 OF 3

CONTROL BOX ASSEMBLY, LX50  
 FOUR WHEEL DRIVE DIESEL/FOUR WHEEL DRIVE  
 DIESEL,DUAL DECK/TWO WHEEL DRIVE DIESEL  
 067527-001

ITEM	PART	DESCRIPTION	QTY.
1	067825-000	ENCLOSURE	1
2	067529-001	PANEL ASSEMBLY, DIESEL 4WD	1
3	064417-001	MOUNTING LATCH	8
4	064443-001	CONTACT BLOCK, N.O.	7
5	064443-002	CONTACT BLOCK, N.C.	3
6	067652-000	PUSH BUTTON, MOM. FLUSH, GREEN	3
7	067653-000	PUSH BUTTON, MOM. EXT. RED	2
8	067654-000	PUSH BUTTON, MOM. FLUSH, BLK.	1
9	066807-003	DOWN ALARM	1
10	029868-007	CIRCUIT BREAKER, 15 AMP.	2
11	064446-003	PUSH BUTTON, MUSHROOM, RED	1
13	064445-001	SELECTOR SWITCH, 3 POS.	1
14	011252-004	SCRW, HHC 1.4-20UNC X 1/2	2
15	011248-006	NUT, SELF LOCKING, 3/8-16	4
16	014996-006	FLATWASHER, 3/8"	4
17	029925-011	CABLE CONNECTOR, 3/4"	4
18	064462-009	HOLE PLUG, Ø 1 1/16	2
19	029939-003	CONDUIT NUT, 3/4"	4
21	066807-001	ALARM, TILT	1
22	014996-004	WASHER 1/4 FLAT	2
23	066516-000	PLUG, HOLE ØØ 2.09	1
24	064462-029	PLUG, 15/16 DIA. FLUSH	1
101	029825-002	DIODE 3 AMP	8
102	029610-002	TERMINAL #8 FORK	35
103	029610-003	TERMINAL #6 FORK	31
104	029731-005	RESTOR, 10 OHM	1
105	029496-099	CABLE 2 COND 16GA	FT22
106	029447-099	CABLE 3 COND 16GA	FT8
107	005491-099	WIRE 16GA GRN/BLK	FT1
108	029450-099	WIRE 16GA BLU	FT8
109	029451-099	WIRE 16GA WHT	FT6
110	029452-099	WIRE 16GA BLK	FT10
111	029456-099	WIRE 16GA YEL	FT2
112	029457-099	WIRE 16GA GRN	FT1
113	029459-099	WIRE 16GA BLU/WHT	FT5
114	029475-099	WIRE 16GA BLU/BLK	FT4
115	029477-099	WIRE 16GA ORN/BLK	FT4
116	029478-099	WIRE 16GA RED/BLK	FT4
117	029482-099	WIRE 16GA GRN/WHT	FT2
118	029483-099	WIRE 16GA RED/WHT	FT2
120	029620-002	CONN, 16GA BUTT	2

# Illustrated Parts Breakdown

Section  
7.2

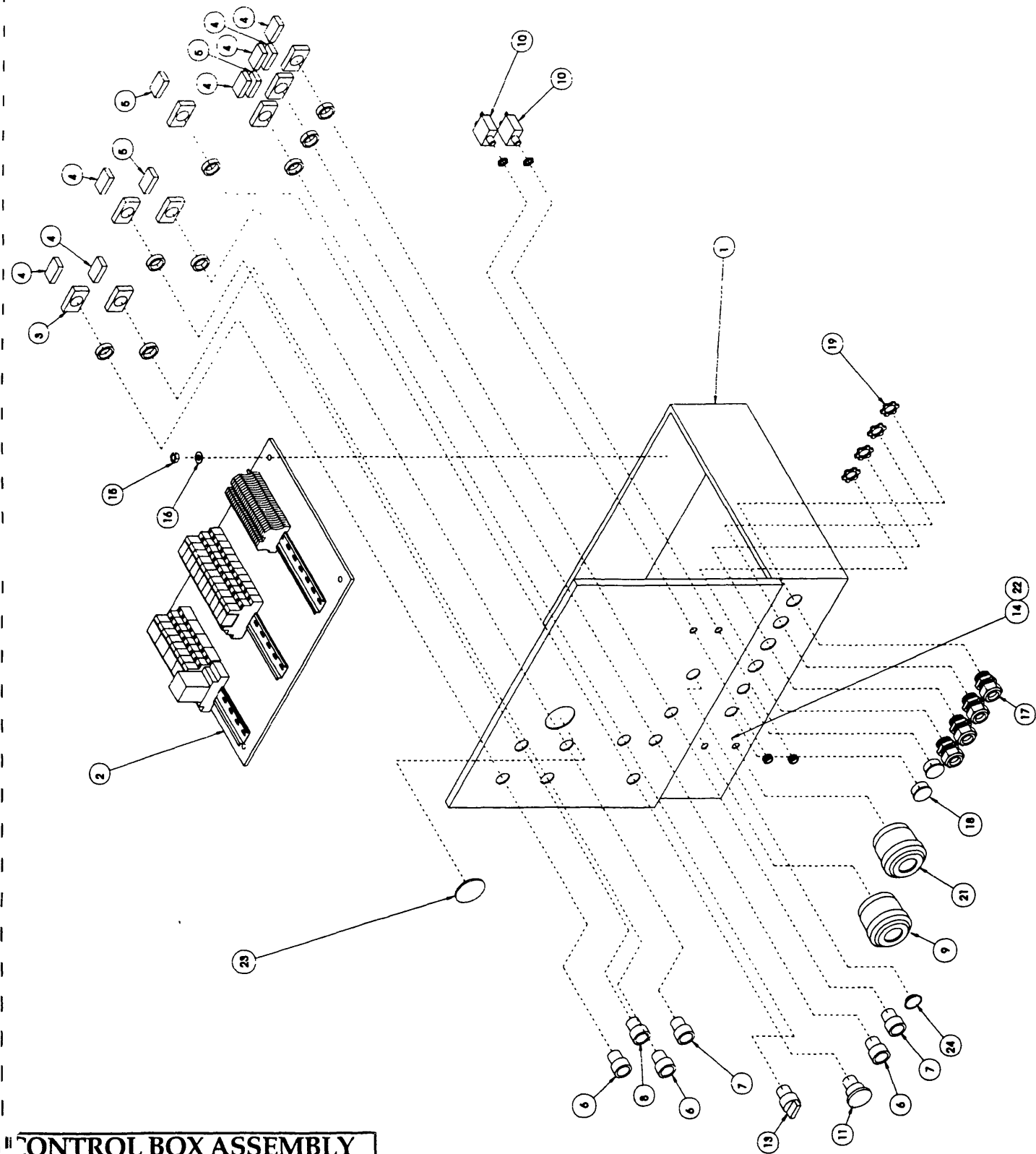

CONTROL BOX ASSEMBLY  
LX50, DIESEL  
DRAWING 1 OF 3

# Illustrated Parts Breakdown

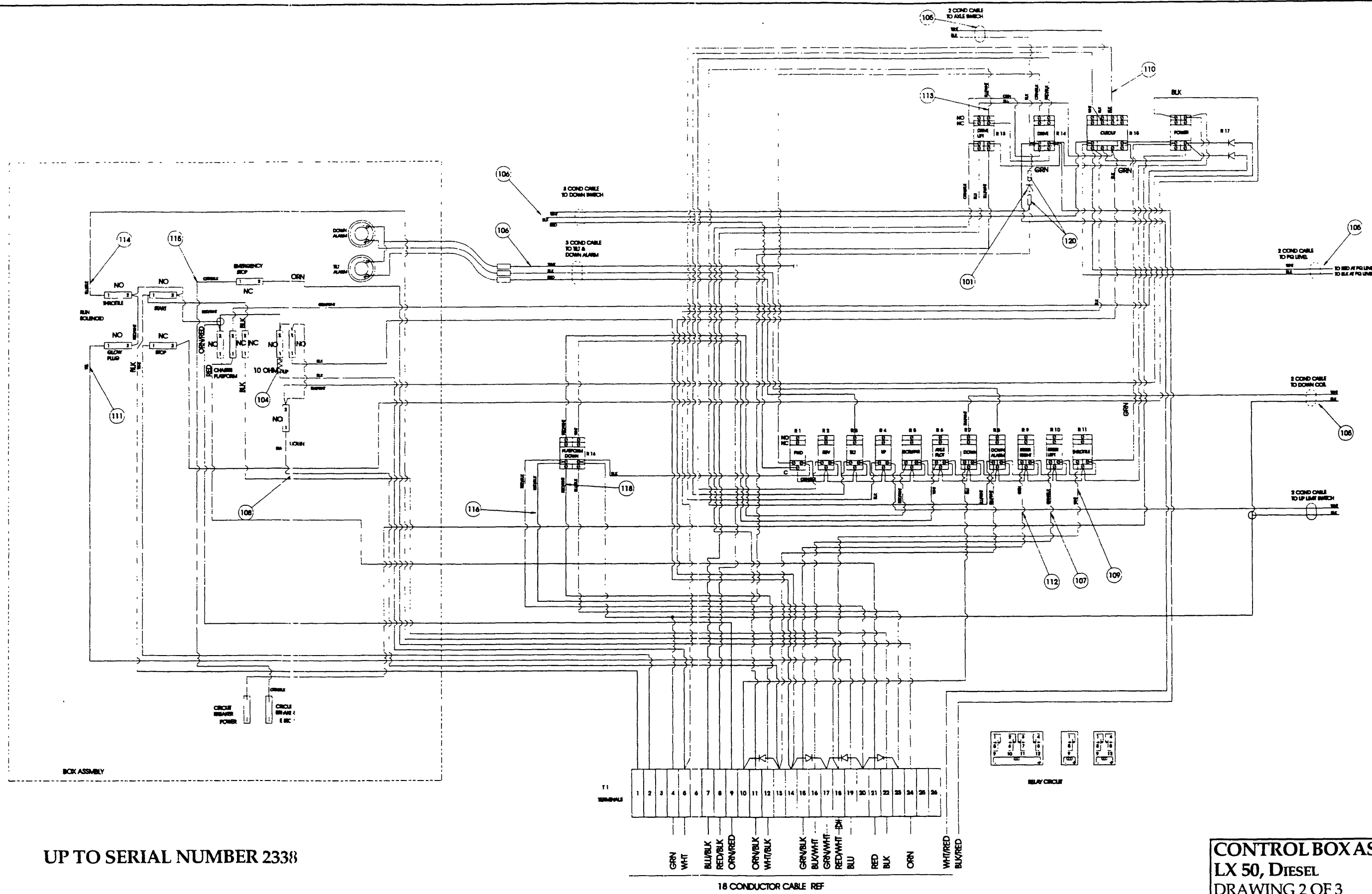

UP TO SERIAL NUMBER 2338

**CONTROL BOX ASSEMBLY**  
LX 50, DIESEL  
DRAWING 2 OF 3

# Illustrated Parts Breakdown

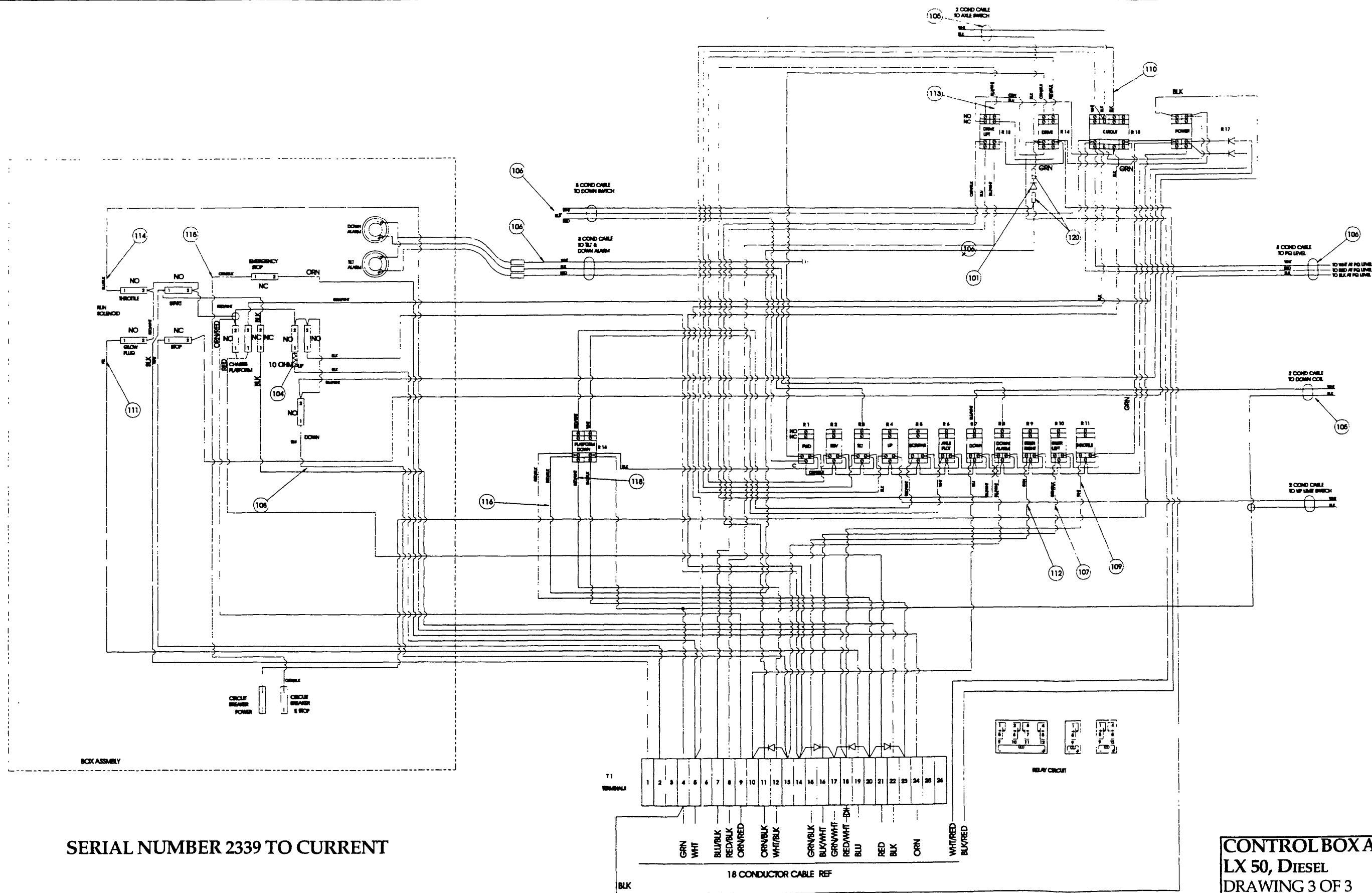

SERIAL NUMBER 2339 TO CURRENT

**CONTROL BOX ASSEMBLY**  
LX 50, DIESEL  
DRAWING 3 OF 3



CONTROL BOX ASSEMBLY, LX50  
 Two Wheel Drive, GAS, DUAL DECK  
 067527-002

ITEM	PART	DESCRIPTION	QTY.
1	067825-000	ENCLOSURE	1
2	067529-003	PANEL ASSEMBLY, DUAL FUEL	1
3	064417-001	MOUNTING LATCH	9
4	064443-001	CONTACT BLOCK, N.O.	8
5	064443-002	CONTACT BLOCK, N.C.	4
6	067652-000	PUSH BUTTON, MOM. FLUSH, GREEN	3
7	067653-000	PUSH BUTTON, MOM. EXT. RED	2
8	067654-000	PUSH BUTTON, MOM. FLUSH, BLK	1
9	066807-003	DOWN ALARM	1
10	029868-007	CIRCUIT BREAKER, 15 AMP	2
11	064446-003	PUSH BUTTON, MUSHROOM, RED	1
13	064445-001	SELECTOR SWITCH, 3 POS.	1
14	011252-004	SCRW, HHC 1/4-20UNC X 1/2	2
15	011248-006	NUT, SELF LOCKING, 3/8-16	4
16	014996-006	FLATWASHER, 3/8"	4
17	029925-011	CABLE CONNECTOR, 3/4"	4
18	064462-009	HOLE PLUG, Ø1.116	2
19	029939-003	CONDUIT NUT, 3/4"	4
21	066807-001	ALARM, TILT	1
22	014996-004	WASHER, 1/4" SAE	2
23	066516-000	PLUG, HOLE 2.09 DIA.	1
24	064445-001	SELECTOR SWITCH, 3 POSITION	1
101	029825-002	DIODE 3 AMP	7
102	029610-002	TERMINAL #8 FORK	37
103	029610-003	TERMINAL #6 FORK	32
104	029731-005	RESISTOR, 10 OHM	1
105	029496-099	CABLE 2 COND 16GA	FT22
106	029447-099	CABLE 3 COND 16GA	FT8
107	005491-099	WIRE 16GA GRN/BLK	FT1
108	029450-099	WIRE 16GA BLU	FT8
109	029451-099	WIRE 16GA WHT	FT7
110	029452-099	WIRE 16GA BLK	FT10
111	029456-099	WIRE 16GA YEL	FT2
112	029457-099	WIRE 16GA GRN	FT1
113	29459-099	WIRE 16GA BLU/WHT	FT5
114	029475-099	WIRE 16GA BLU/BLK	FT6
115	029477-099	WIRE 16GA ORN/BLK	FT4
116	029478-099	WIRE 16GA RED/BLK	FT4
117	029482-099	WIRE 16GA GRN/WHT	FT2
118	029483-099	WIRE 16GA RED/WHT	FT2
120	029620-002	CONN 16GA BUTT	2

# Illustrated Parts Breakdown

Section  
7.2

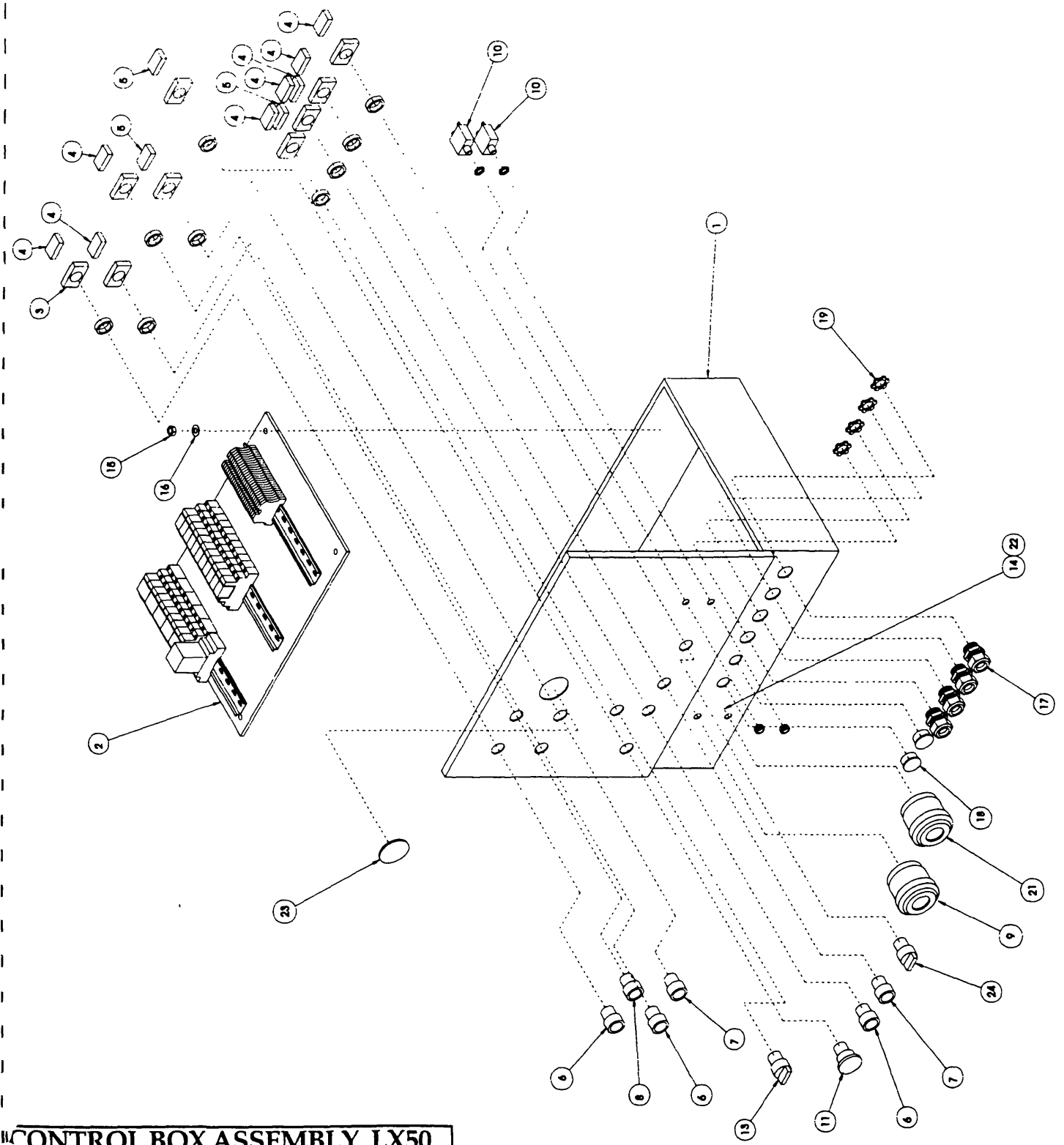

CONTROL BOX ASSEMBLY, LX50  
TWO WHEEL DRIVE, GAS, DUAL DECK  
DRAWING 1 OF 3

# Illustrated Parts Breakdown

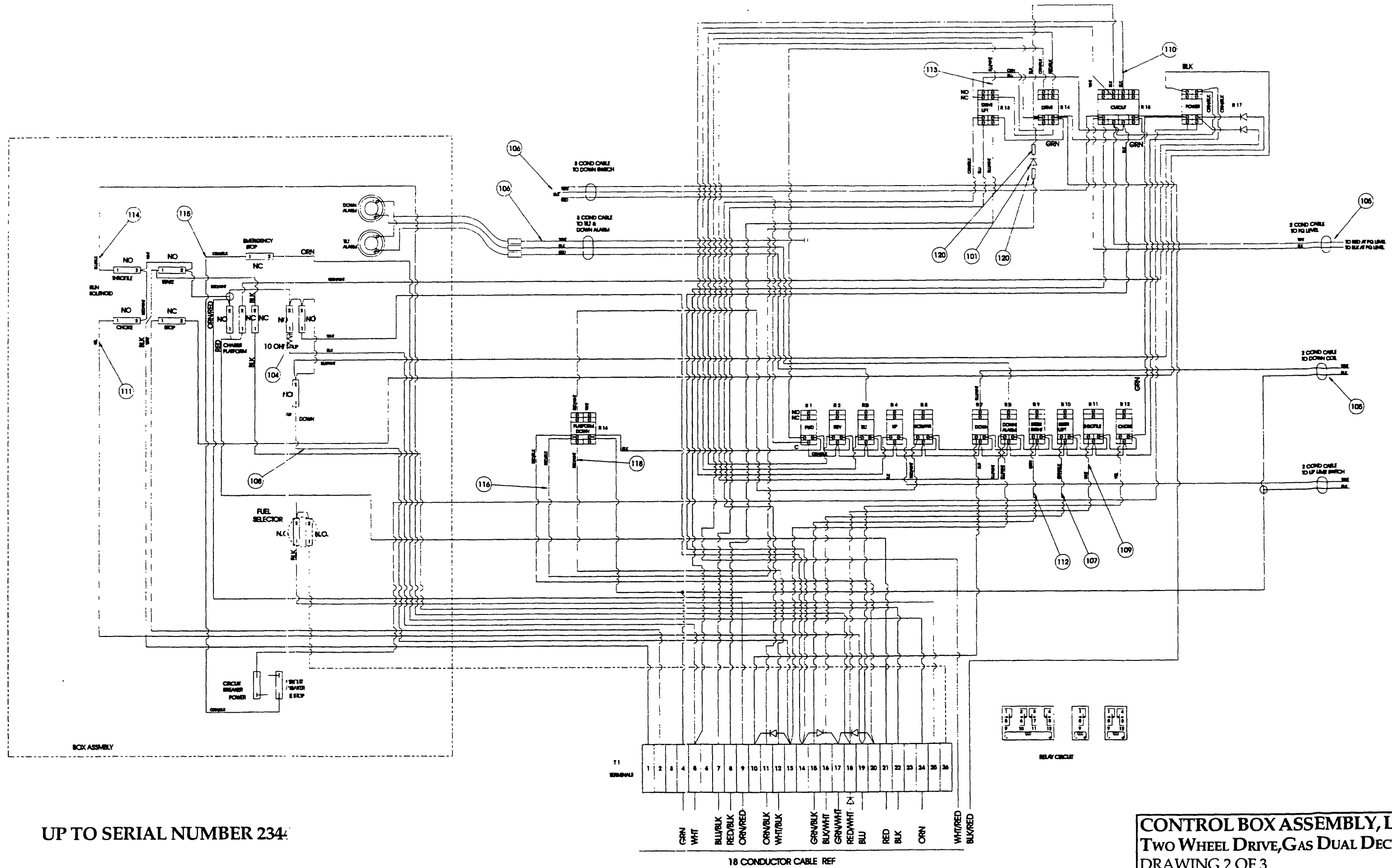

# Illustrated Parts Breakdown

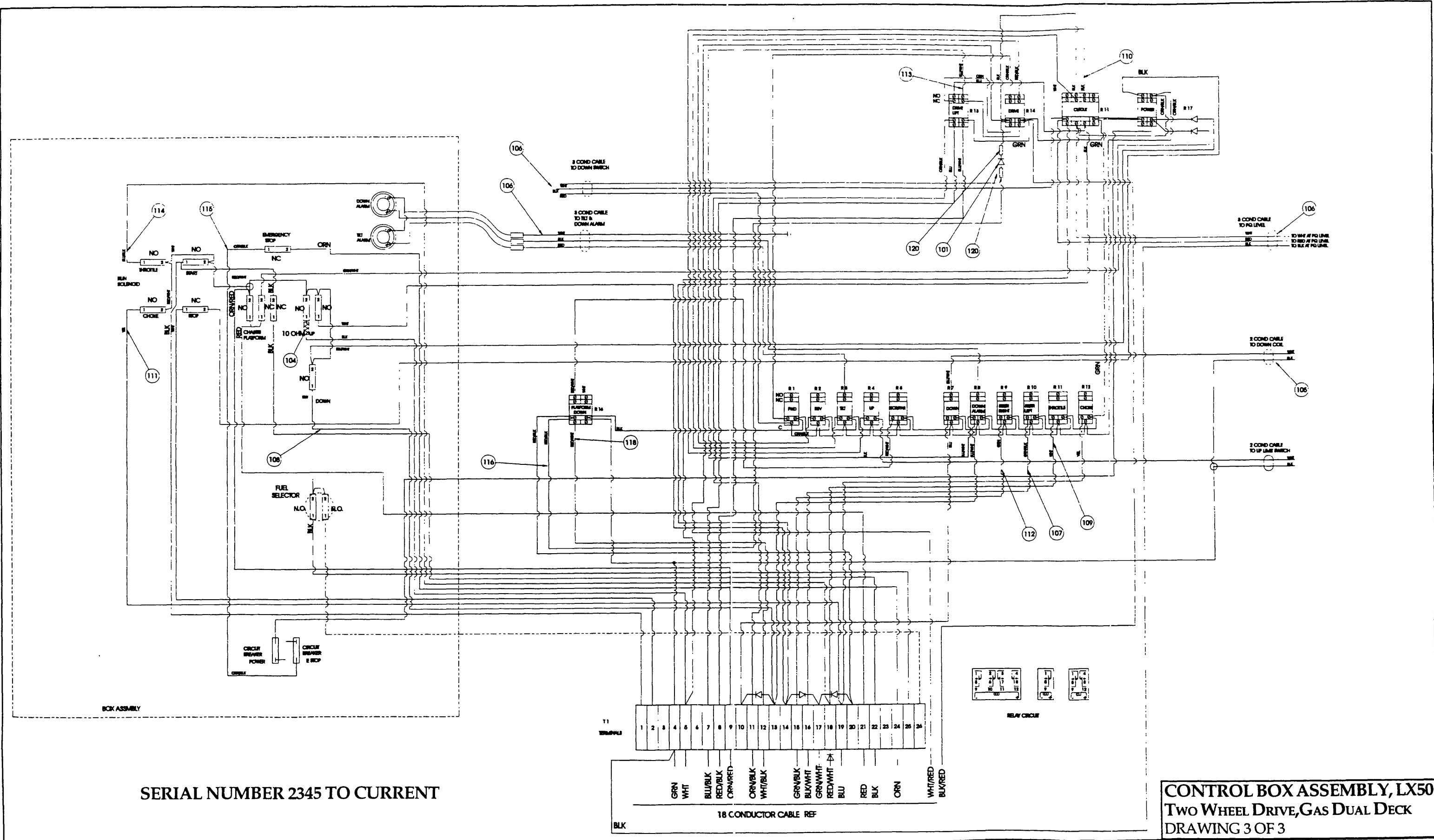

**CONTROL BOX ASSEMBLY, LX50**  
**Two WHEEL DRIVE, DIESEL, DUAL DECK**  
 067527-003

ITEM	PART	DESCRIPTION	QTY.
1	067825-000	ENCLOSURE	1
2	067529-002	PANEL ASSEMBLY, DIESEL 2WD	1
3	064417-001	MOUNTING LATCH	8
4	064443-001	CONTACT BLOCK, N.O	7
5	064443-002	CONTACT BLOCK, N.C	3
6	067652-000	PUSH BUTTON, MOM. FLUSH, GREEN	3
7	067653-000	PUSH BUTTON, MOM. EXT. RED	2
8	067654-000	PUSH BUTTON, MOM. FLUSH, BLK	1
9	066807-003	DOWN ALARM	1
10	029868-007	CIRCUIT BREAKER, 15 AMP.	2
11	064446-003	PUSH BUTTON, MUSHROOM, RED	1
13	064445-001	SELECTOR SWITCH, 3 POS	1
14	011252-004	SCRW, HHC 1/4-20 OUNC X 1/2	2
15	011248-006	NUT, SELF LOCKING, 3/8-16	4
16	014996-006	FLATWASHER, 3/8"	4
17	029925-011	CABLE CONNECTOR, 3/4"	4
18	064462-009	HOLE PLUG, Ø1 1/16	2
19	029939-003	CONDUIT NUT, 3/4"	4
21	066807-001	ALARM, TILT	1
22	014996-004	WASHER, 1/4" SAE	2
23	066516-000	PLUG, HOLE 2.09 DIA.	1
24	064462-029	PLUG, 15/16 DIA. FLUSH	1
101	029825-002	DIODE 3 AMP	8
102	029610-002	TERMINAL #8 FORK	35
103	029610-003	TERMINAL #6 FORK	31
104	029731-005	RESISTOR, 10 OHM	1
105	029496-099	CABLE 2 COND 16GA	FT22
106	029447-099	CABLE 3 COND 16GA	FT8
107	005491-099	WIRE 16GA GRN/BLK	FT1
108	029450-099	WIRE 16GA BLU	FT8
109	029451-099	WIRE 16GA WHT	FT6
110	029452-099	WIRE 16GA BLK	FT10
111	029456-099	WIRE 16GA YEL	FT2
112	029457-099	WIRE 16GA GRN	FT1
113	029459-099	WIRE 16GA BLU/WHT	FT5
114	029475-099	WIRE 16GA BLU/BLK	FT4
115	029477-099	WIRE 16GA ORN/BLK	FT4
116	029478-099	WIRE 16GA RED/BLK	FT4
117	029482-099	WIRE 16GA GRN/WHT	FT2
118	029483-099	WIRE 16GA RED/WHT	FT2
120	029620-002	CONN 16GA BUTT	2

# Illustrated Parts Breakdown

Section  
7.2

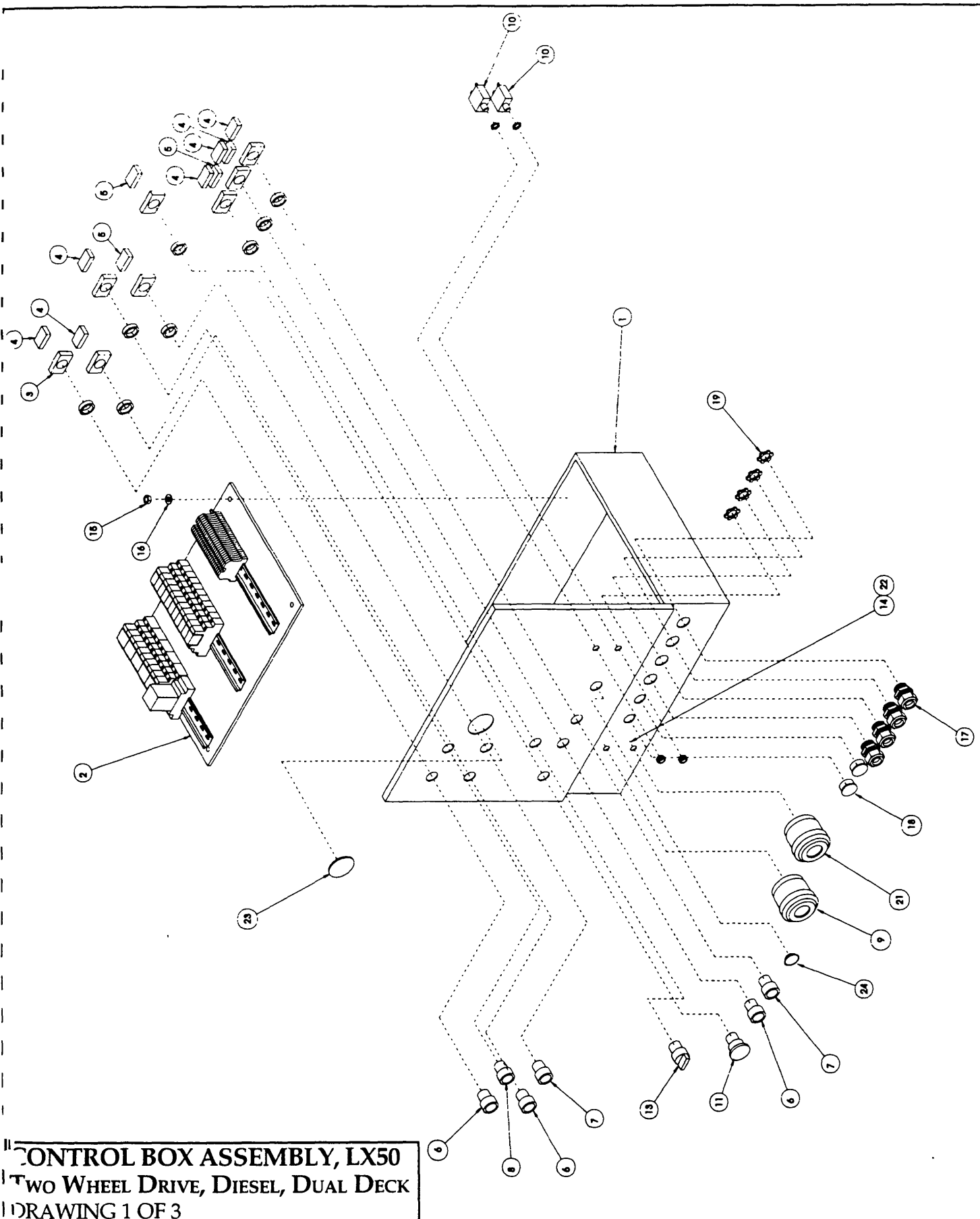

CONTROL BOX ASSEMBLY, LX50  
TWO WHEEL DRIVE, DIESEL, DUAL DECK  
DRAWING 1 OF 3

# Illustrated Parts Breakdown

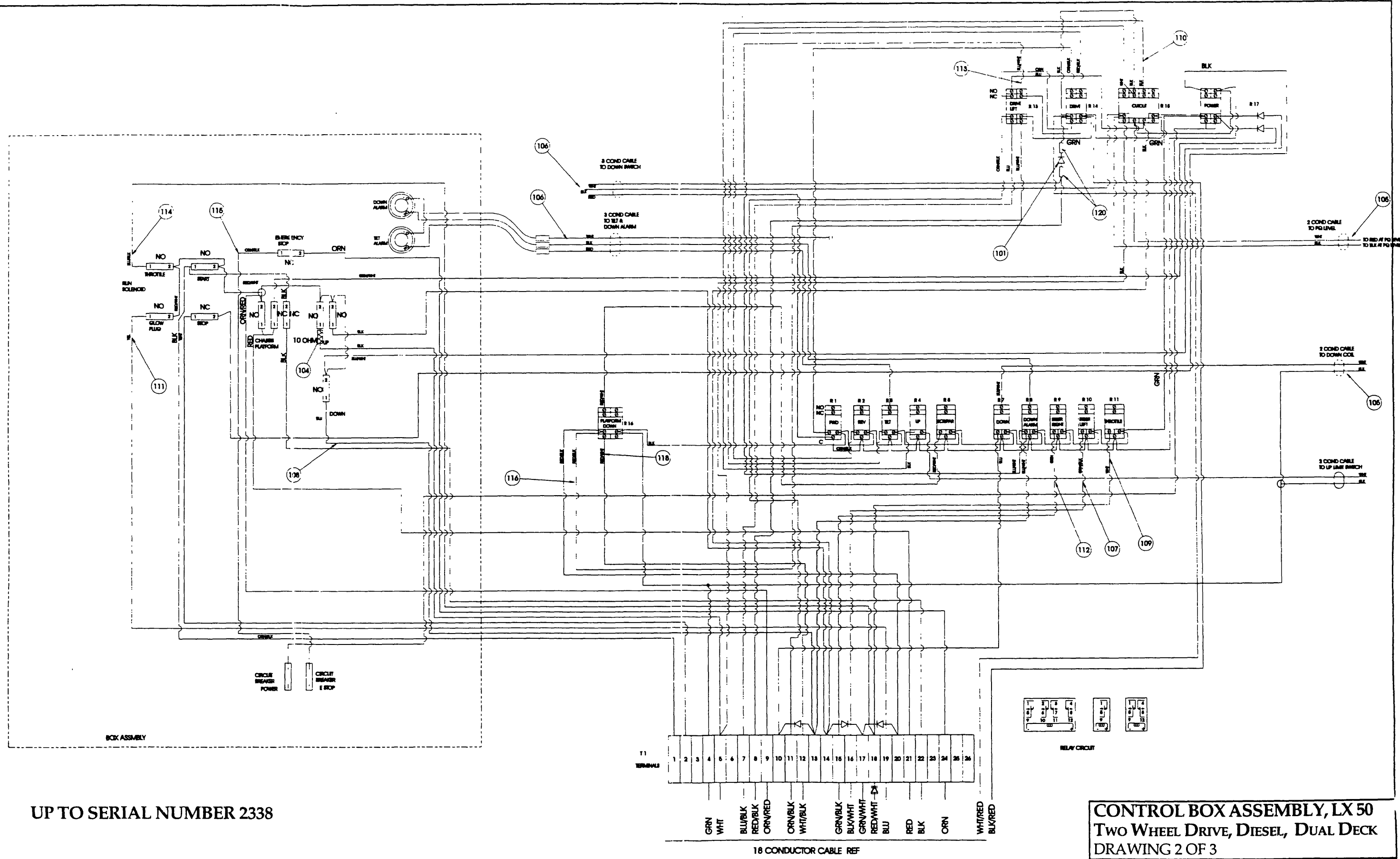

**CONTROL BOX ASSEMBLY, LX 50**  
**TWO WHEEL DRIVE, DIESEL, DUAL DECK**  
**DRAWING 2 OF 3**

# Illustrated Parts Breakdown

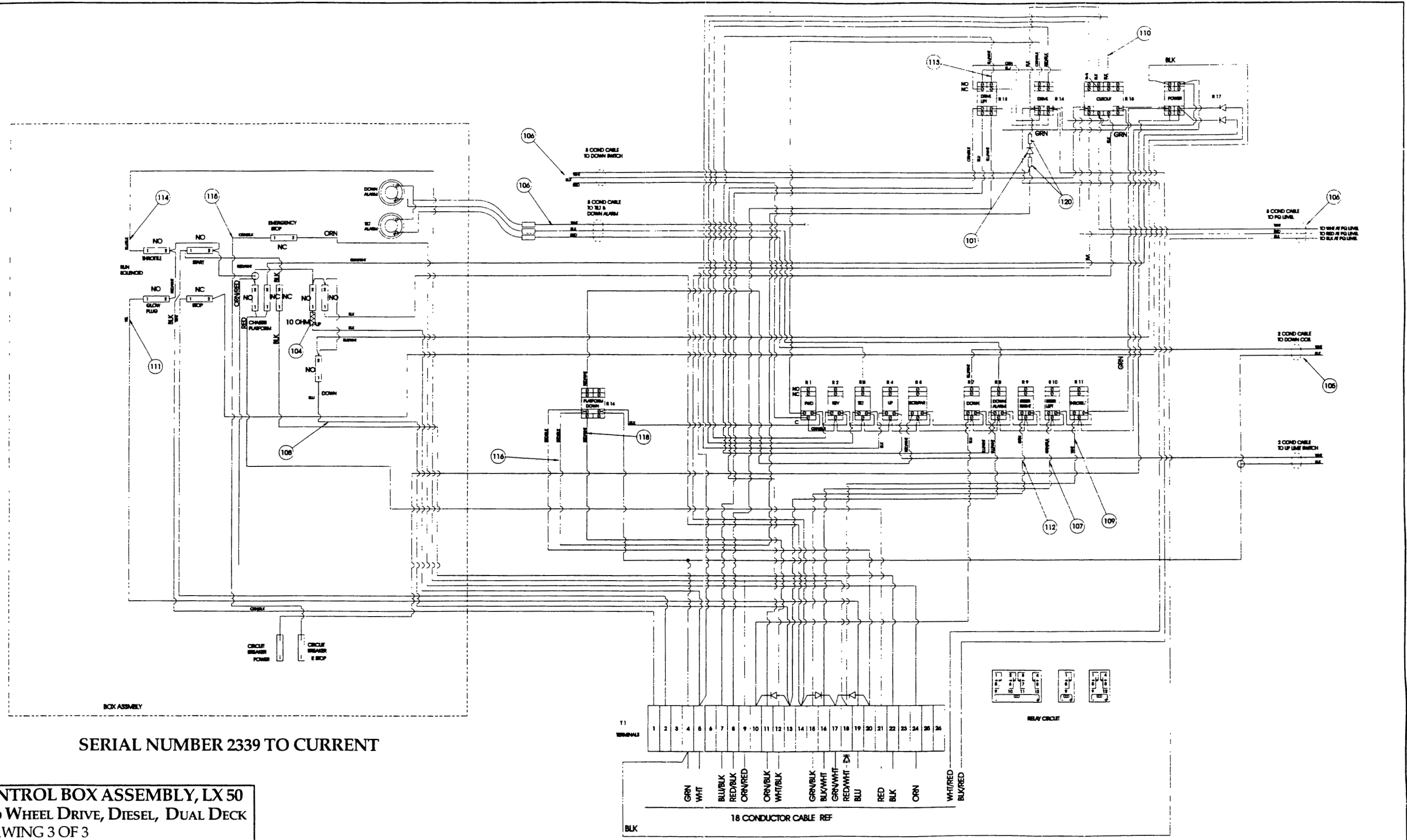

SERIAL NUMBER 2339 TO CURRENT

**CONTROL BOX ASSEMBLY, LX 50**  
**TWO WHEEL DRIVE, DIESEL, DUAL DECK**  
**DRAWING 3 OF 3**



**PANEL ASSEMBLY, LX50**  
**FOUR WHEEL DRIVE, GAS & DUAL FUEL**  
 067529-000

ITEM	PART	DESCRIPTION	QTY.
1	067727-000	PLATE, MOUNTING	1
2	067893-000	MOUNTING RAIL, 12"	3
3	067661-001	RELAY, SPDT	12
4	067661-002	RELAY, DPDT	4
5	067661-004	RELAY, QPDT	1
6	067662-001	SOCKET, RELAY	12
7	067662-002	SOCKET, RELAY	4
8	067662-004	SOCKET, RELAY	1
9	067662-005	RETAINER CLIP	12
10	067662-006	RETAINER CLIP	4
11	067662-007	RETAINER CLIP	1
12	067660-001	TERMINAL BLOCK	13
13	067660-002	TERMINAL BLOCK, BLUE	13
14	067660-003	TERMINAL BLOCK, GROUND	1
15	067660-006	END BRACKET	2
16	011709-004	SCREW	6
17	014996-003	WASHER	6
18	011248-003	ESNA NUT	6

**PANEL ASSEMBLY, LX50**  
**FOUR WHEEL DRIVE, DIESEL**  
 067529-001

ITEM	PART	DESCRIPTION	QTY.
1	067727-000	PLATE, MOUNTING	1
2	067893-000	MOUNTING RAIL, 12"	3
3	067661-001	RELAY, SPDT	12
4	067661-002	RELAY, DPDT	4
5	067661-004	RELAY, QPDT	1
6	067662-001	SOCKET, RELAY	12
7	067662-002	SOCKET, RELAY	4
8	067662-004	SOCKET, RELAY	1
9	067662-005	RETAINER CLIP	12
10	067662-006	RETAINER CLIP	4
11	067662-007	RETAINER CLIP	1
12	067660-001	TERMINAL BLOCK	12
13	067660-002	TERMINAL BLOCK, BLUE	12
14	067660-003	TERMINAL BLOCK, GROUND	1
15	067660-006	END BRACKET	2
16	011709-004	SCREW	6
17	014996-003	WASHER	6
18	011248-003	ESNA NUT	6

**PANEL ASSEMBLY, LX50**  
**TWO WHEEL DRIVE, DIESEL**  
 067529-002

ITEM	PART	DESCRIPTION	QTY.
1	067727-000	PLATE, MOUNTING	1
2	067893-000	MOUNTING RAIL, 12"	3
3	067661-001	RELAY, SPDT	11
5	067661-004	RELAY, QPDT	1
4	067661-002	RELAY, DPDT	4
6	067662-001	SOCKET, RELAY	12
7	067662-002	SOCKET, RELAY	4
8	067662-004	SOCKET, RELAY	1
9	067662-005	RETAINER CLIP	12
10	067662-006	RETAINER CLIP	4
11	067662-007	RETAINER CLIP	1
12	067660-001	TERMINAL BLOCK	12
13	067660-002	TERMINAL BLOCK, BLUE	11
14	067660-003	TERMINAL BLOCK, GROUND	1
15	067660-006	END BRACKET	2
16	011709-004	SCREW	6
17	014996-003	WASHER	6
18	011248-003	ESNA NUT	6

**PANEL ASSEMBLY, LX50**  
**TWO WHEEL DRIVE, GAS & DUAL FUEL**  
 067529-003

ITEM	PART	DESCRIPTION	QTY.
1	067727-000	PLATE, MOUNTING	1
2	067893-000	MOUNTING RAIL, 12"	3
3	067661-001	RELAY, SPDT	11
4	067661-002	RELAY, DPDT	4
5	067661-004	RELAY, QPDT	1
6	067662-001	SOCKET, RELAY	12
7	067662-002	SOCKET, RELAY	4
8	067662-004	SOCKET, RELAY	1
9	067662-005	RETAINER CLIP	12
10	067662-006	RETAINER CLIP	4
11	067662-007	RETAINER CLIP	1
12	067660-001	TERMINAL BLOCK	13
13	067660-002	TERMINAL BLOCK, BLUE	11
14	067660-003	TERMINAL BLOCK, GROUND	1
15	067660-006	END BRACKET	2
16	011709-004	SCREW	6
17	014996-003	WASHER	6
18	011248-003	ESNA NUT	6

# Illustrated Parts Breakdown

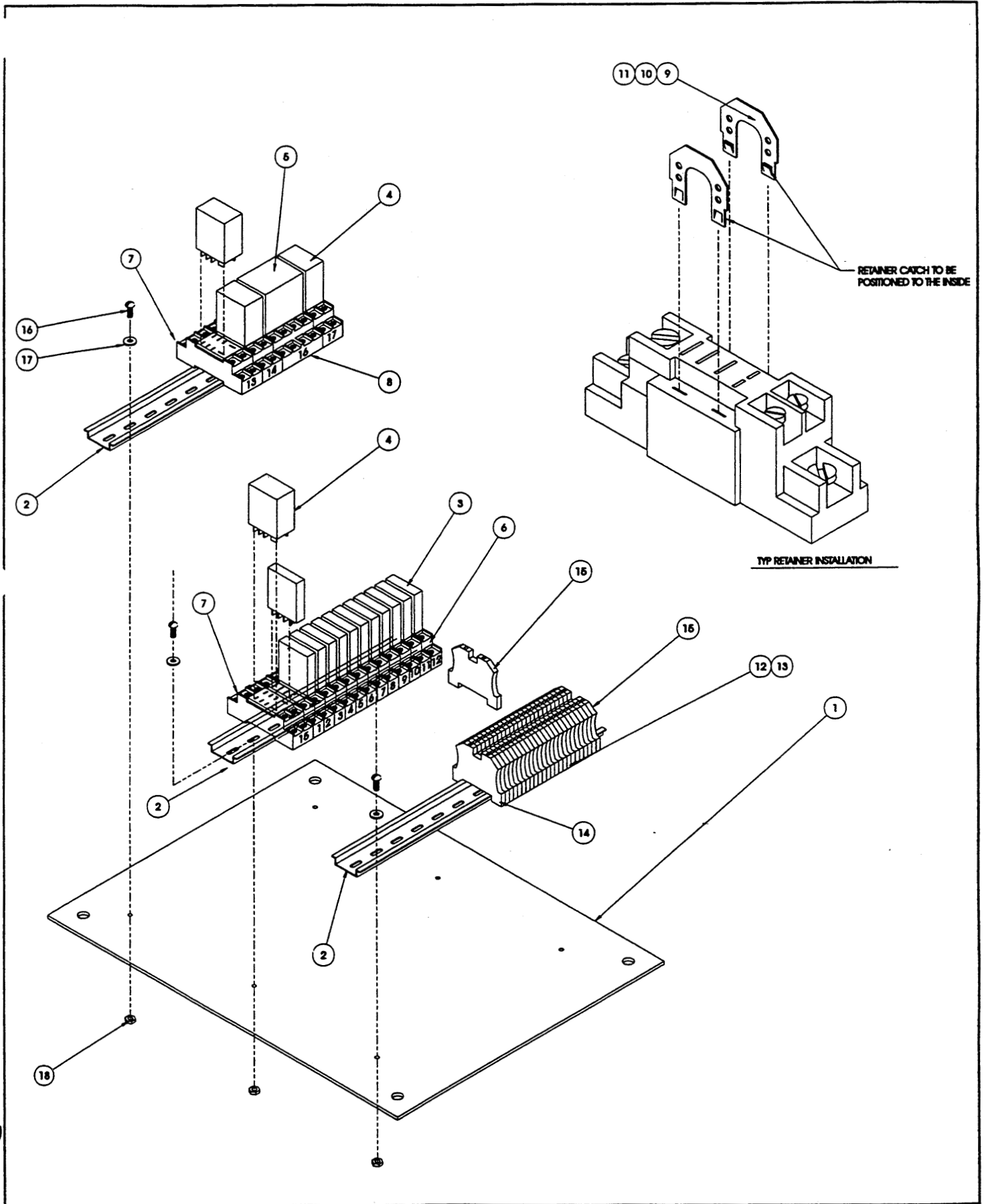

## CONTROLLER ASSEMBLY

LX50

067528-000

ITEM	PART	DESCRIPTION	QTY.
1	067802-000	ENCLOSURE BOX	1
2	067643-001	CONTROLLER, PROPORTIONAL 12V	1
*	015772-001	SWITCH, MICRO	1
*	066544-014	SWITCH, STEERING	1
*	063913-003	BOOT, STEERING SWITCH	2
*	063913-004	ROCKER ASSEMBLY	1
*	066544-010	HANDLE, 2 PIECE	1
*	066544-011	LEVER, INTERLOCK	1
*	066544-012	SWITCH, INTERLOCK	1
*	066544-013	BOOT, JOYSTICK SHAFT	1
*	066544-015	FLANGE, CONTROLLER MOUNTING	1
3	064417-001	MOUNTING LATCH	4
4	064462-007	CAP PLUG 7/8 DIA.	2
5	029925-011	CABLE CONNECTOR, 3/4"	1
6	029939-002	CONDUIT NUT, 1/2"	2
7	029939-003	CONDUIT NUT, 3/4"	1
8	064666-000	KEY SWITCH	1
*	063936-015	KEY ONLY	1
9	067657-000	SELECTOR SWITCH	2
10	067653-000	PUSH BUTTON	1
11	064446-003	MUSHROOM BUTTON	1
12	068133-000	INDICATOR LIGHT	1

ITEM	PART	DESCRIPTION	QTY.
13	067806-000	RING, RETAINING	1
14	063951-001	RELAY	1
15	064443-001	CONTACT BLOCK, N.O.	2
16	064443-002	CONTACT BLOCK, N.C.	3
17	066094-001	PANEL, CONTROLLER L.H.	1
18	067889-000	REAR PLATE, CONTROLLER HANGER	1
19	066095-001	PANEL, CONTROLLER R.H.	1
20	026551-007	RIVET, POP 1/8 .251-.312 GRIP	6
21	064462-002	CAPLUG 1/2" DIA.	4
22	011253-004	SCREW HHC 5/16-18UNC X 1/2	4
23	011715-004	SCREW, #6-32 X 1/2	2
24	011248-047	LOCKNUT, #6-32	2
101	029610-004	CONNECTOR FORK TERM 12-10 GA. #10	15
102	029620-002	CONNECTOR BUTT. 16-14 GA.	4
103	029615-002	CONNECTOR FEMALE PUSH 16-14 GA.	4
104	029452-099	WIRE 16 GA. BLACK	FT1
105	029450-099	WIRE 16 GA. BLUE	FT3
106	029482-099	WIRE 16 GA. GRN/WHT	FT1
109	029453-099	WIRE 16 GA. ORG	FT1
110	063956-003	PLUG, HOUSING	1
111	063956-010	PIN, CONTACT MALE	11
112	029477-099	WIRE 16 GA. ORG/BLK	FT1
113	029454-099	WIRE 16 GA. RED	FT2

\* Not Shown

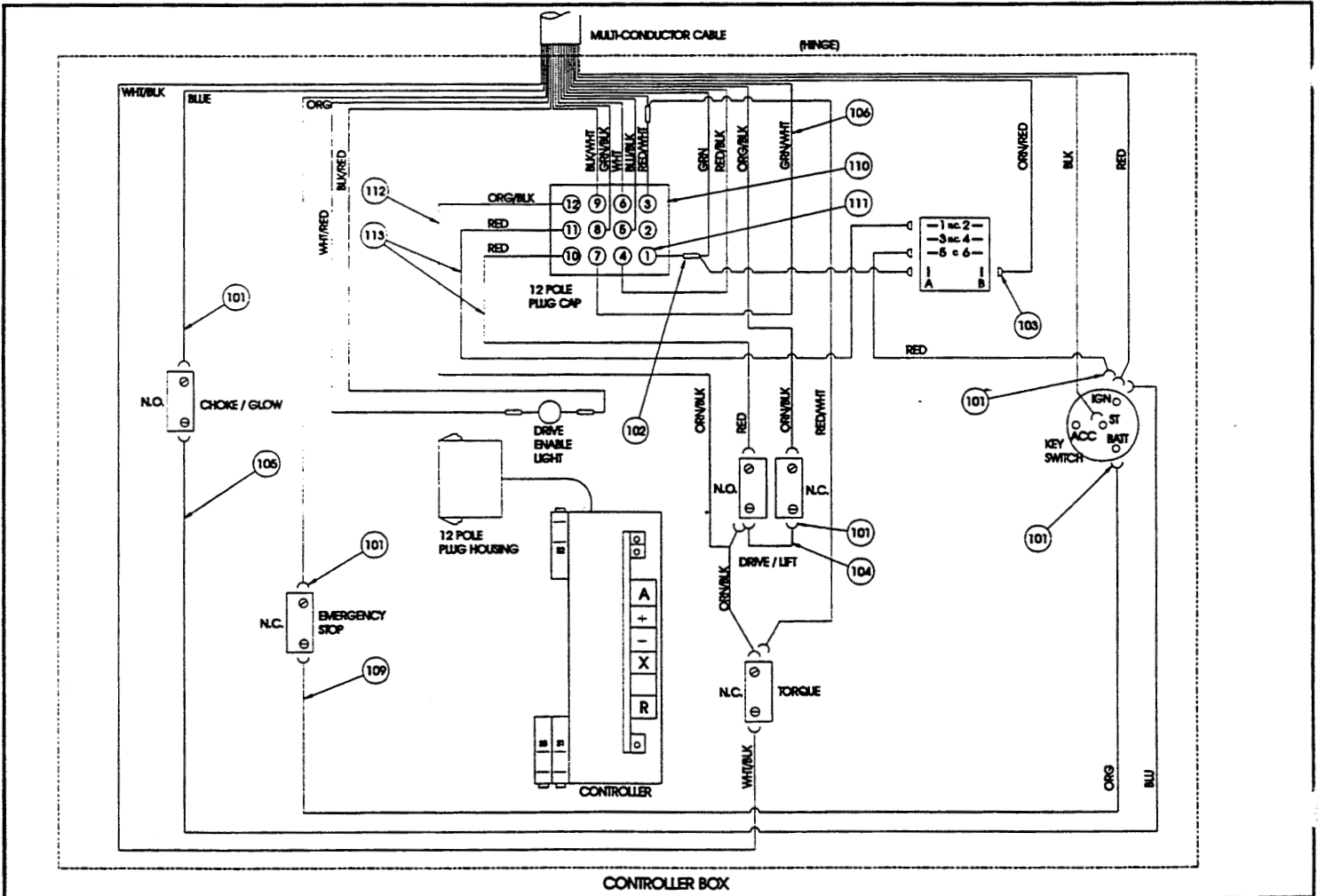

# Illustrated Parts Breakdown

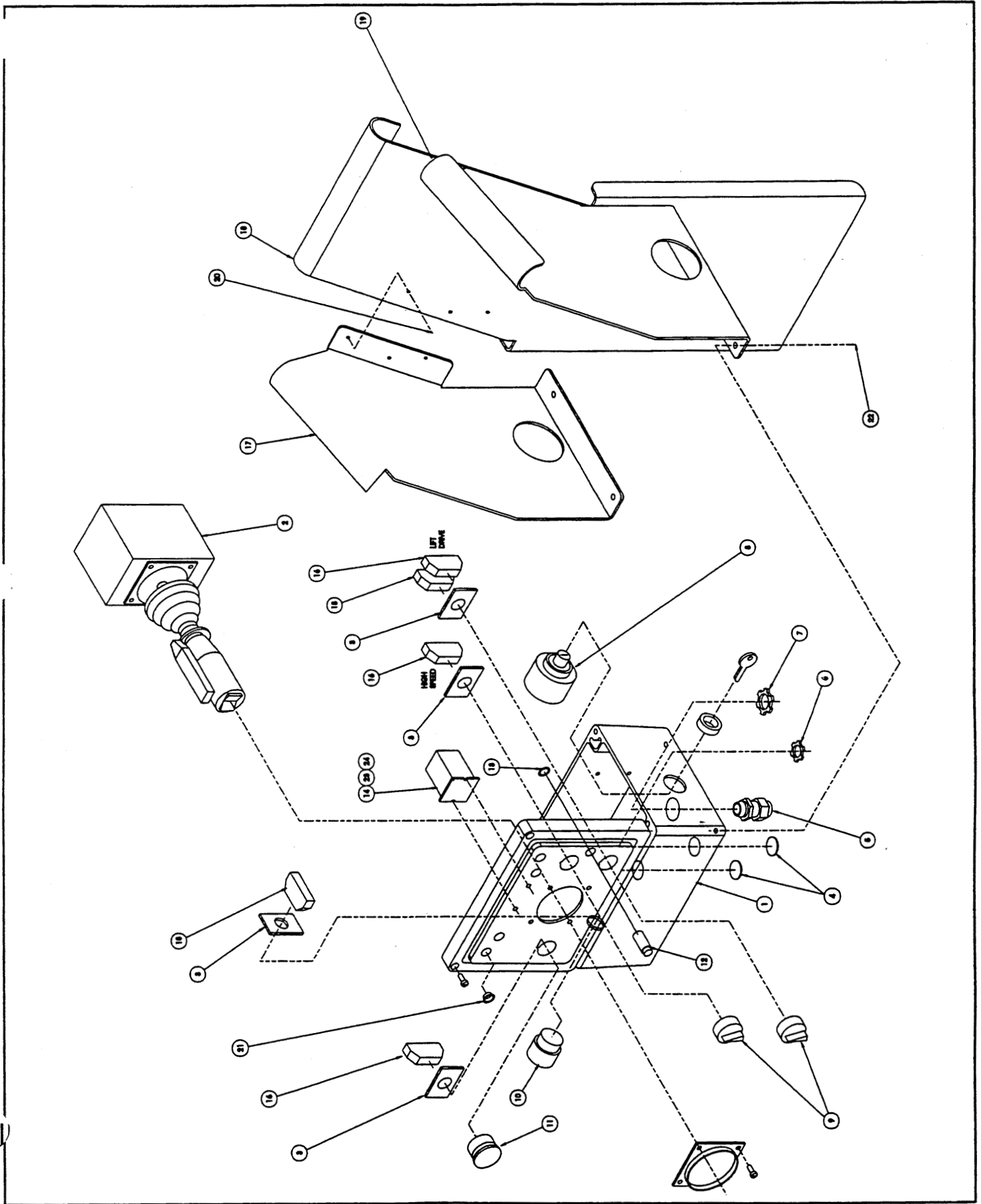

GUARDRAIL ASSEMBLY, LX  
WITHOUT SLIDEOUT DECK  
067530-005

ITEM	PART	DESCRIPTION	QTY.
1	REF	PLATFORM WELDMENT	1
2	067751-002	SIDE GUARDRAIL WELDMENT	3
3	067751-001	GUARDRAIL WELDMENT R.H.	1
4	067883-000	GATE WELDMENT	1
5	003570-000	RETAINING PIN ASSY	1
6	062642-026	BEARING	2
7	066526-002	TORSION SPRING	1
8	067764-001	GATE KICKRAIL WELDMENT	1
9	011254-008	SCREW HHC 3/8-16UNC X 1	7
10	011254-032	SCREW HHC 3/8-16UNC X 4	8
11	064046-000	BRACKET, RAIL MOUNTING	6
12	011248-006	NUT HEX ESNA 3/8-16UNC	31
13	011254-018	SCREW HHC 3/8-16UNC X 2 1/4	4
14	011254-036	SCREW HHC 3/8-16UNC X 4-1/2	2
15	067881-000	END GUARDRAIL WELDMENT	1
16	067880-001	END GUARDRAIL WELDMENT	1
17	011254-014	SCREW HHC 3/8-16UNC X 1 3/4	8
18	067757-000	KICKRAIL WELDMENT	2
19	011254-020	SCR HHC 3/8-16 X 2-1/2	2
20	067712-000	PIVOT TUBE WELDMENT	1
21	067695-000	SPACER	6
22	011739-014	ROLLPIN 3/8D X 1 3/4	1
23	011240-006	WASHER, FLAT STD 3/8	4
24	63666-004	WIRE CHANNEL	1
25	11253-012	SCREW HHC 5/16-18 X 1 1/2	2
26	11240-005	WASHER 5/16 FLAT	2
27	11250-005	NUT 5/16-18 HEX	2
28	67885-000	END RAIL WELDMENT	1

# Illustrated Parts Breakdown

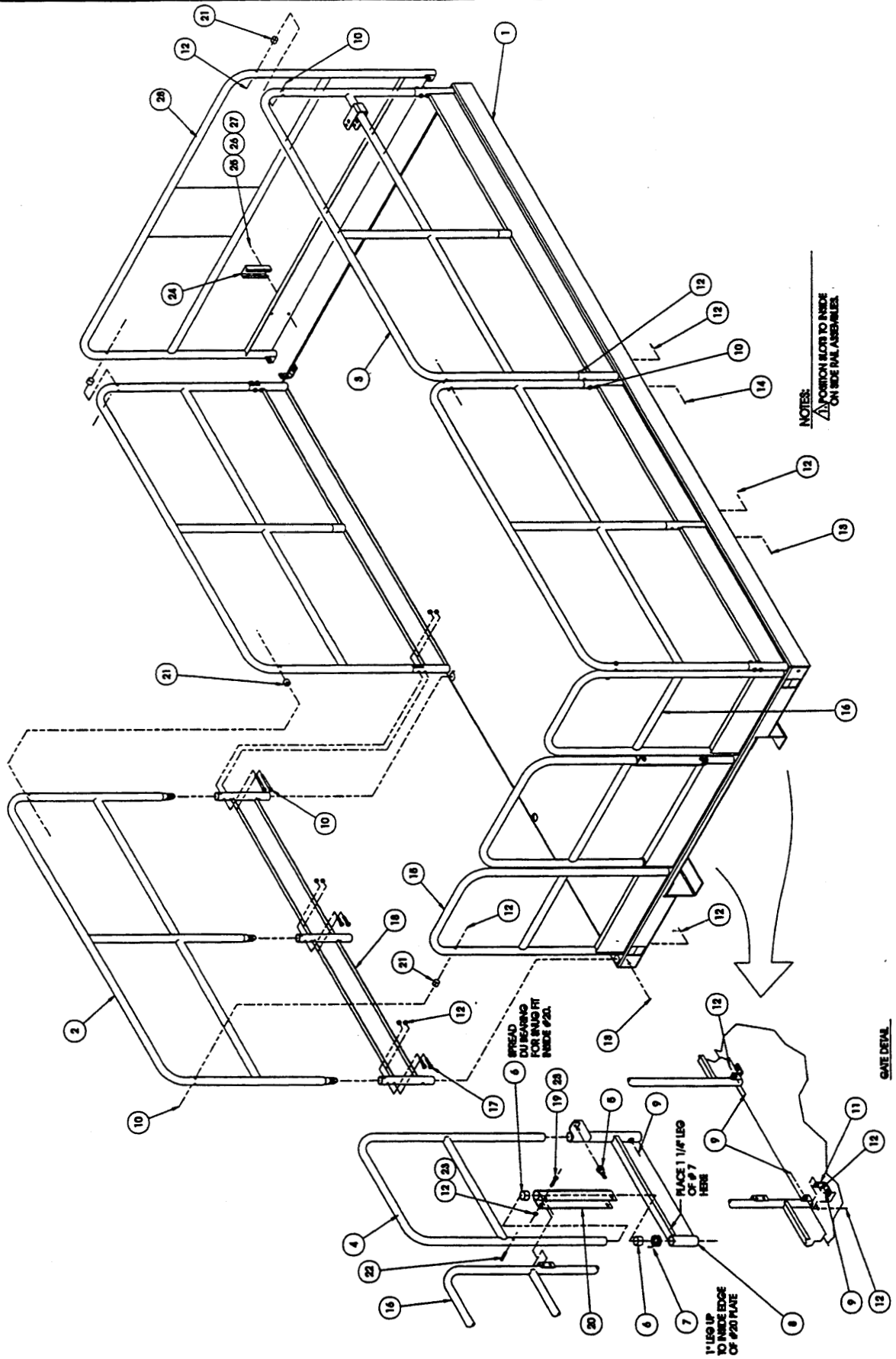

**GUARDRAIL ASSEMBLY, LX**  
**WITH SLIDEOUT DECK**  
067530-004

ITEM	PART	DESCRIPTION	QTY.
1	REF	PLATFORM WELDMENT	1
2	067751-002	SIDE GUARDRAIL WELDMENT	3
3	067751-001	GUARDRAIL WELDMENT R.H.	1
4	067883-000	GATE WELDMENT	1
5	003570-000	RETAINING PIN ASSY	1
6	062642-026	BEARING	2
7	066526-002	TORSION SPRING	1
8	067764-001	GATE KICKRAIL WELDMENT	1
9	011254-008	SCREW HHC 3/8-16UNC X 1	7
10	011254-032	SCREW HHC 3/8-16UNC X 4	6
11	064046-000	BRACKET, RAIL MOUNTING	6
12	011248-006	NUT HEX ESNA 3/8-16UNC	29
13	011254-018	SCREW HHC 3/8-16UNC X 2 1/4	4
14	011254-036	SCREW HHC 3/8-16UNC X 4-1/2	2
15	067881-000	END GUARDRAIL WELDMENT	1
16	067880-001	END GUARDRAIL WELDMENT	1
17	011254-014	SCREW HHC 3/8-16UNC X 1 3/4	8
18	067757-000	KICKRAIL WELDMENT	2
19	011254-020	SCR HHC 3/8-16 X 2-1/2	2
20	067712-000	PIVOT TUBE WELDMENT	1
21	067695-000	SPACER	4
22	011739-014	ROLLPIN 3/8D X 1 3/4	1
23	011240-006	WASHER, FLAT STD 3/8	4

# Illustrated Parts Breakdown

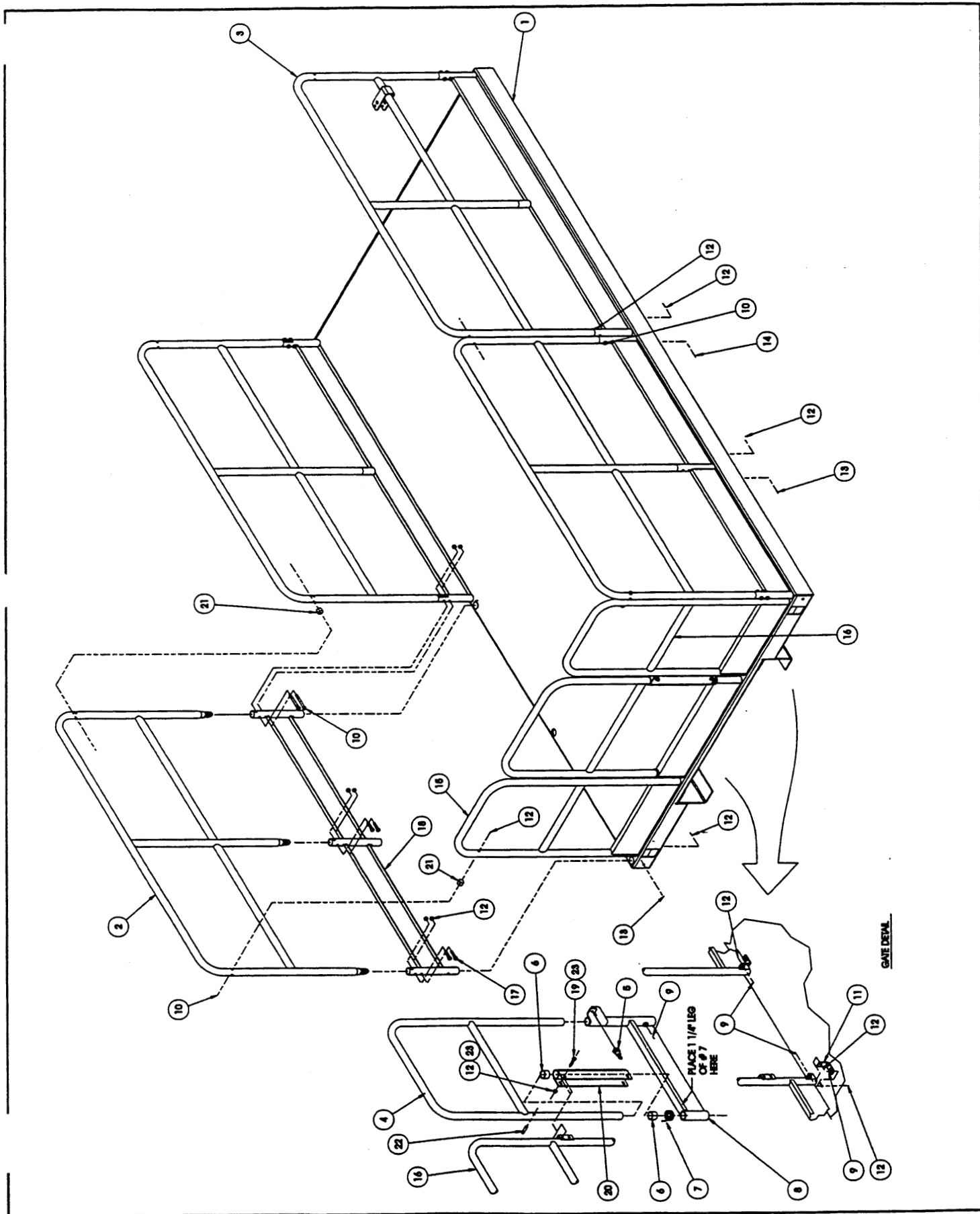



**GUARDRAIL ASSEMBLY**  
**LX DUAL DECK**  
030867-300

ITEM	PART	DESCRIPTION	QTY.
1	030841-101	PLATFORM WELDMENT	REF
2	030841-018	GIARDRAIL WELDMENT	2
4	067883-000	GATE WELDMENT	1
5	003570-000	RETAINING PIN ASSY	1
6	062642-026	BEARING	2
7	066526-002	TORSION SPRING	1
8	067764-001	GATE KICKRAIL WELDMENT	1
9	011254-008	SCREW HHC 3/8-16UNC X 1	6
10	030841-020	GUARDRAIL WELDMENT 3	1
11	030841-021	GUARDRAIL WELDMENT 4	1
12	011248-006	NUT HEX ESNA 3/8-16UNC	60
13	011254-018	SCREW HHC 3/8-16UNC X 2 1/4	28
14	030841-040	STEP WELDMENT	1
15	030841-054	CENTER GUARDRAIL WELDMENT	1
16	067755-001	SWING TUBE	12
17	011254-014	SCREW HHC 3/8-16UNC X 1 3/4	24
19	011254-20	SCR HHC 3/8-16 X 2-1/2	2
20	030841-013	PIVOT TUBE WELDMENT	1
21	067695-000	SPACER	6
22	011739-014	ROLLPIN 3/8D X 1 3/4	1
23	011240-006	WASHER, FLAT STD 3/8	8

# Illustrated Parts Breakdown

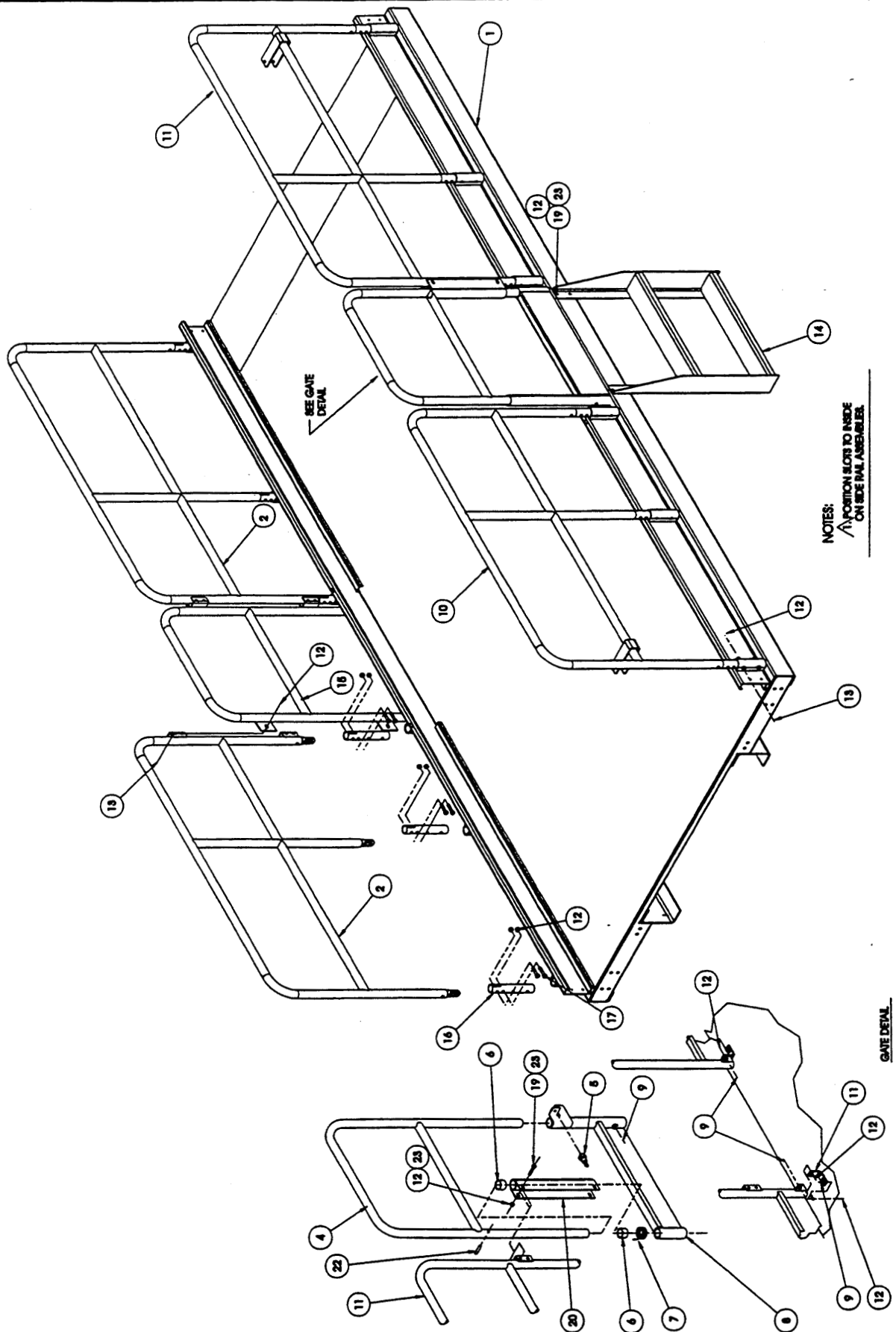

SLIDEOUT DECK ASSEMBLY  
LX50, DUAL DECK  
067886-001

ITEM	PART	DESCRIPTION	QTY.
2	067787-001	SLIDE-OUT DECK WELDMENT	1
3	067760-002	WHEEL, SLIDE-OUT DECK	2
4	066193-000	STOP	2
5	067720-000	ROLLER	2
6	067818-001	ARM, CABLE GUIDE	2
7	067786-001	BRACKET, CABLE GUIDE	1
8	067761-000	PIVOT, PUSH BAR	2
9	067862-003	HANDLE WELDMENT	2
10	066170-002	WEAR PAD	2
11	067776-001	GUARDRAIL WELDMENT	2
12	067778-000	GUARDRAIL WELDMENT	1
13	067755-001	SWING TUBE	2
14	011848-038	CLEVIS PIN, 1/2" DIA. X 2-1/2	2
15	026553-008	RIVET POP ØØ3/16 X .5-.63 GRIP	4
16	011757-005	COTTER PIN, RUE RING	2
17	014996-006	WASHER, FLAT 3/8" DIA	40
18	067695-000	SPACER	4
19	011248-006	LOCKNUT, 3/8-16 UNC ESNA	32
20	012865-099	LOOM, WIRE 3/4"	FT. 1
21	011254-008	SCR. HHC 3/8-16 UNC X 1	10
22	011254-014	SCR. HHC 3/8-16 UNC X 1 3/4	4
23	011254-006	SCR. HHC 3/8-16 UNC X 3/4	8
24	015936-014	SCR. SHOU 3/8-16 UNC X 1 3/4	10
25	011254-032	SCR. HHC 3/8-16 UNC X 4	4
26	067920-000	SPACER, GUARDRAIL	2
27	060086-000	SAFETY WALK (20 X 32)	4
28	066557-001	LABEL PLATFORM CAPY	1
29	067867-001	ROLLER BRACKET REAR WELDMENT L.H.	1
30	067867-000	ROLLER BRACKET REAR WELDMENT R.H.	1
31	063666-004	WIRE CHANNEL	1
32	011253-012	SCR. HHC 5/16-18 X 1-1/2	2
33	011248-005	NUT HEX 5/16-18 ESNA	2
34	011240-005	WASHER 5/16 FLAT STD	4
35	010414-000	LOCKING PIN ASSY 5/16" ØØ	1
36	066556-000	LABEL, WARNING DESEND PLTFM	2
38	066198-000	WEAR PAD	2
39	011252-012	SCR. HH 1/4-20 X 1-1/2	4
40	011248-004	1/4-20 ESNA NUT	4
41	015770-099	HOSE 3/8 DIA X 1-1/2 LG	1
42	067783-003	ROLLER BRACKET RH	2
43	067783-004	ROLLER BRACKET LH	2

# Illustrated Parts Breakdown

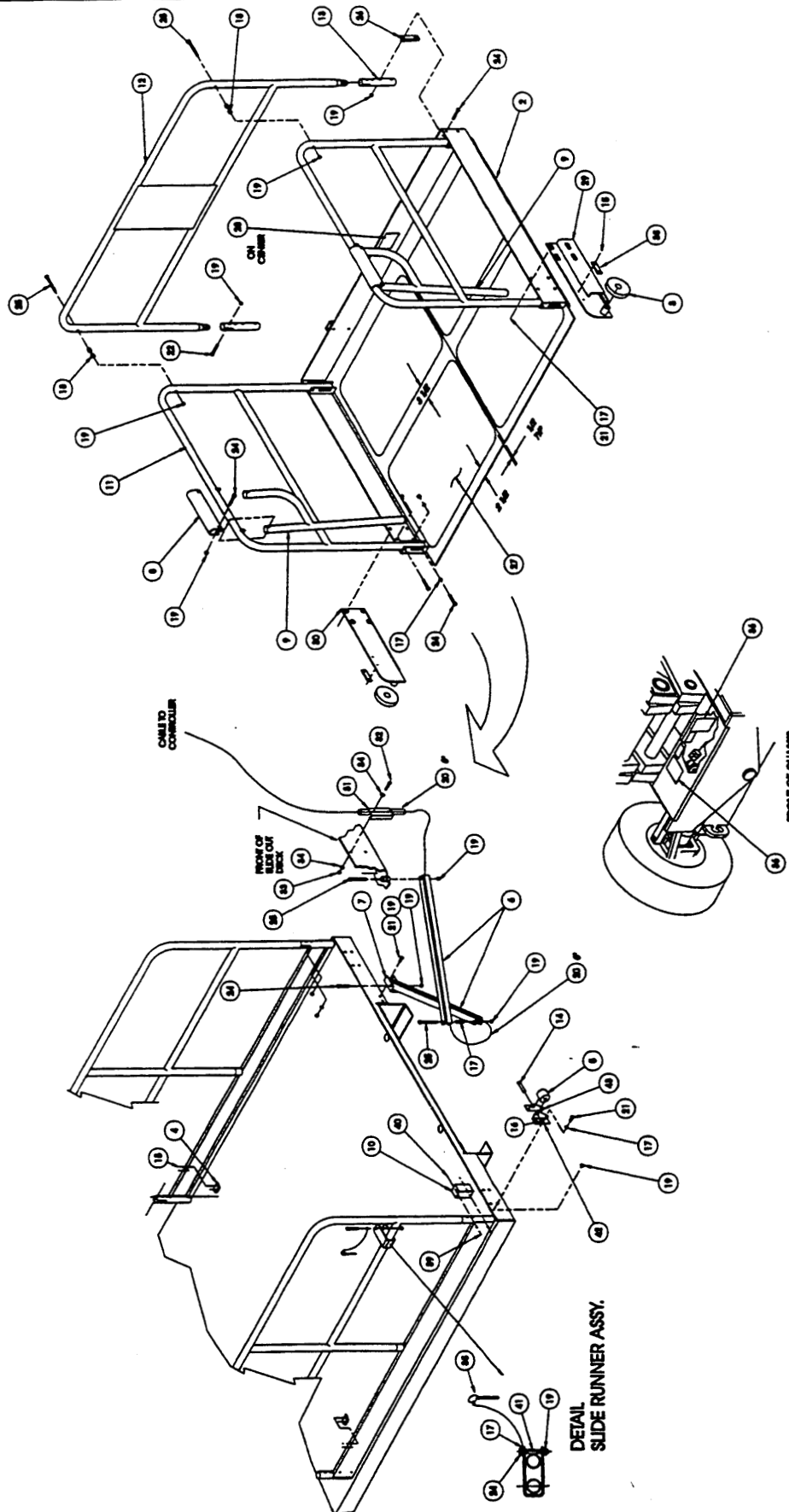

## SLIDEOUT DECK ASSEMBLY - REAR

LX50, DUAL DECK

067886-002

ITEM	PART	DESCRIPTION	QTY.
2	067787-001	SLIDE-OUT DECK WELDMENT	1
3	067760-002	WHEEL, SLIDE-OUT DECK	2
4	066193-000	STOP	2
5	067720-000	ROLLER	2
8	067761-000	PIVOT, PUSH BAR	2
9	067862-003	HANDLE WELDMENT	2
10	066170-002	WEAR PAD	2
11	067776-001	GUARDRAIL WELDMENT	2
12	067778-000	GUARDRAIL WELDMENT	1
13	067755-001	SWING TUBE	2
14	011848-038	CLEVIS PIN, 1/2" DIA. X 2-1/2	2
15	026553-008	RIVET POP ØØ3/16 X .5-.63 GRIP	4
16	011757-005	COTTER PIN, RUE RING	2
17	014996-006	WASHER, FLAT 3/8" DIA	37
18	067695-000	SPACER	4
19	011248-006	LOCKNUT, 3/8-16 UNC ESNA	27
21	011254-008	SCR. HHC 3/8-16 UNC X 1	8
22	011254-014	SCR. HHC 3/8-16 UNC X 1 3/4	4
23	011254-006	SCR. HHC 3/8-16 UNC X 3/4	8
24	015936-014	SCR. SHOU 3/8-16 UNC X 1 3/4	9
25	011254-032	SCR. HHC 3/8-16 UNC X 4	2
26	067920-000	SPACER, GUARDRAIL	2
27	060086-000	SAFETY WALK (20 X 32)	4
28	066557-001	LABEL PLATFORM CAPY	1
29	067867-001	ROLLER BRACKET REAR WELDMENT L.H.	1
30	067867-000	ROLLER BRACKET REAR WELDMENT R.H.	1
35	010414-000	LOCKING PIN ASSY 5/16" ØØ	1
36	066556-000	LABEL, WARNING DESEND PLTFM	1
38	066198-000	WEAR PAD	2
39	011252-012	SCR. HH 1/4-20 X 1-1/2	4
40	011248-004	1/4-20 ESNA NUT	4
41	015770-099	HOSE 3/8 DIA X 1-1/2 LG	1
42	067783-003	ROLLER BRACKET RH	2
43	067783-004	ROLLER BRACKET LH	2

# Illustrated Parts Breakdown

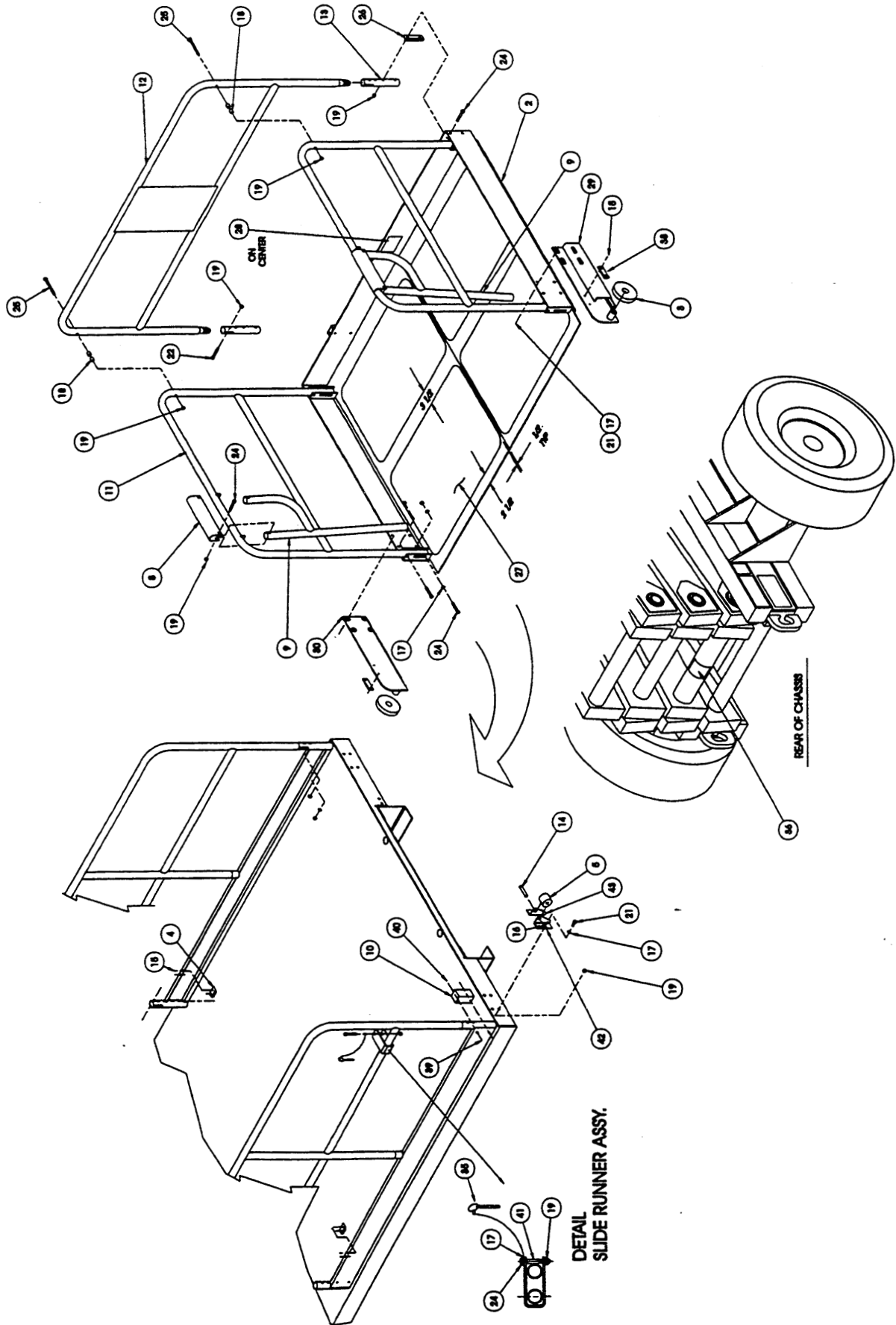

HOSE ASSEMBLY, LX50  
Two Wheel Drive  
067533-012

ITEM	PART	DESCRIPTION	QTY.
1	067680-027	1-1/4 HOSE ASSY X 27 20FJX-20FJX 90°	1
3	067857-334	3/8 HOSE ASSY X 334 6FJX-6FJX 90°	1
4	067676-131	3/4 HOSE ASSY X 131 12FJX-12FJX 90°	1
6	067682-026	1/2 HOSE ASSY X 26 8FJX-8FJX 90°	1
7	067858-108	3/4 HOSE ASSY X 108 12FJX-12FJX	1
8	065234-096	1/4 HOSE ASSY X 96 4FJX-4FJX	1
10	060861-136	3/8 HOSE ASSY X 136 6FJX-6FJX	1
11	060861-141	3/8 HOSE ASSY X 141 6FJX-6FJX	1
12	060861-102	3/8 HOSE ASSY X 529 6FJX-6FJX	1
13	060861-103	3/8 HOSE ASSY X 370 6FJX-6FJX	2
15	067683-085	3/8 HOSE ASSY X 85 6FJX-6FJX45°	2
18	067677-144	5/8 HOSE ASSY X 144 10FJX-10FJX90°	2
19	067684-200	3/8 HOSE ASSY X 200 6FJX-6FJX90°	1
20	067677-112	5/8 HOSE ASSY X 112 10FJX-10FJX90°	2
21	065234-152	1/4 HOSE ASSY X 152 4FJX-4FJX	1
22	065234-014	1/4 HOSE ASSY X 46.5 4FJX-4FJX	1
24	065234-032	1/4 HOSE ASSY X 32 4FJX-4FJX	1
25	065234-001	1/4 HOSE ASSY X 20 4FJX-4FJX	1
26	067685-030	1/2 HOSE ASSY X 30 12MP-10FJX	1
28	067689-022	1/8 HOSE ASSY X 22 2MP-4FJX	1
29	020032-001	FITTING 4MJ-4MJ TEE	REF

# Illustrated Parts Breakdown

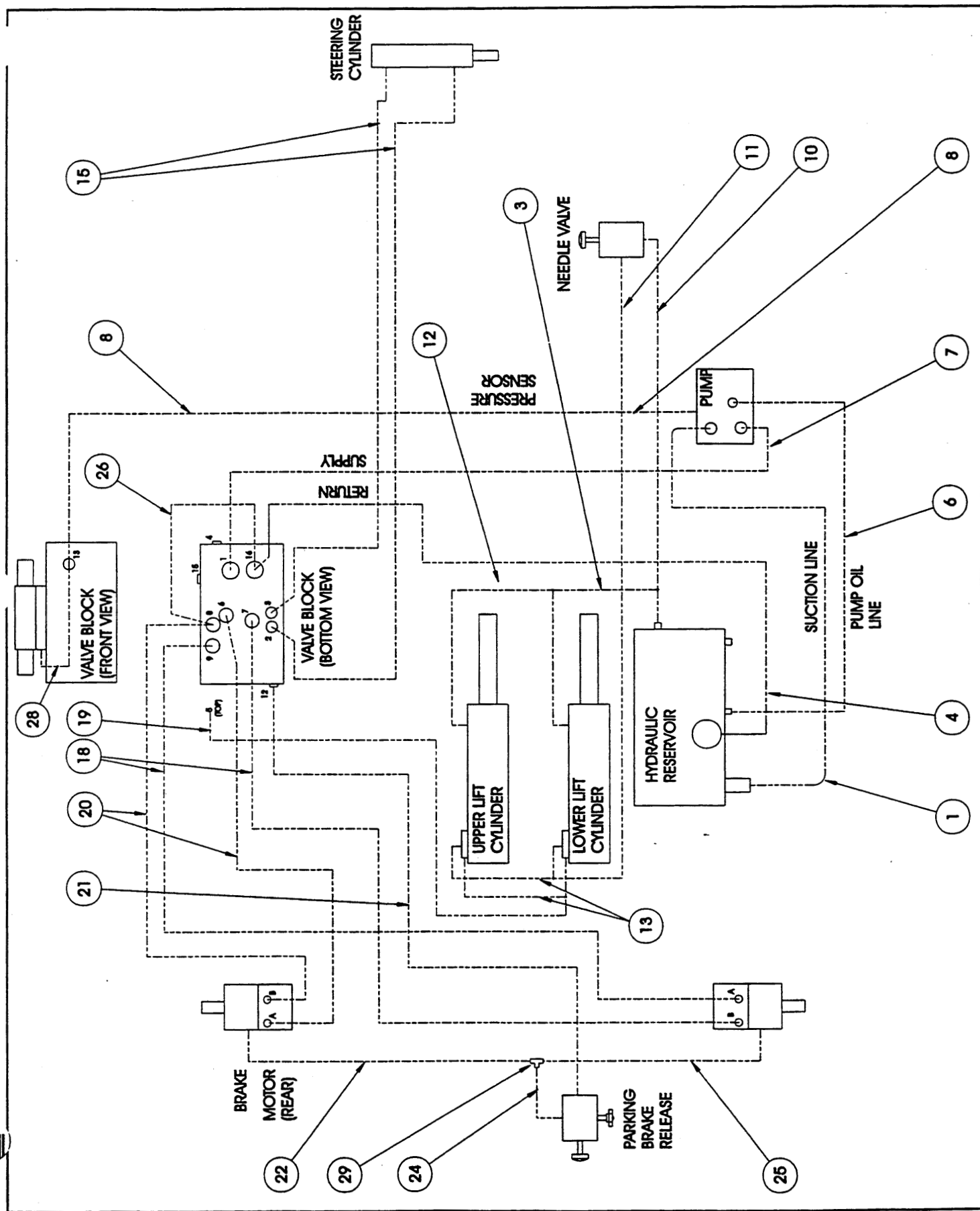



## HOSE ASSEMBLY, LX50

## FOUR WHEEL DRIVE

067533-013

ITEM	PART	DESCRIPTION	QTY.
1	067680-027	1-1/4 HOSE ASSY X 27 20FJX-20FJX 90°	1
2	062192-009	1/4 HOSE ASSY X 65 4FJX-4FJX	1
3	067857-334	3/8 HOSE ASSY X 334 6FJX-6FJX90°	1
4	067676-131	3/4 HOSE ASSY X 131 12FJX-12FJX 90°	1
5	067681-120	1/4 HOSE ASSY X 120 4FJX-4FJX 90°	1
6	067682-026	1/2 HOSE ASSY X 26 8FJX-8FJX 90°	1
7	067858-108	3/4 HOSE ASSY X 108 12FJX-12FJX	1
8	065234-096	1/4 HOSE ASSY X 96 4FJX-4FJX	1
9	067679-044	1/2 HOSE ASSY X 44 10FJX-8FJX 45°	4
11	067681-080	1/4 HOSE ASSY X 80 4FJX-4FJX 90°	1
12	067918-008	1/8 HOSE ASSY X 8 4FJX-4FJX	2
13	067681-100	1/4 HOSE ASSY X 100 4FJX-4FJX 90°	1
14	067681-115	1/4 HOSE ASSY X 115 4FJX-4FJX 90°	1
15	067683-085	3/8 HOSE ASSY X 85 6FJX-6FJX 45°	2
16	067677-090	5/8 HOSE ASSY X 90 10FJX-10FJX 90°	1
17	067677-060	5/8 HOSE ASSY X 60 10FJX-10FJX 90°	1
18	067677-144	5/8 HOSE ASSY X 144 10FJX-10FJX 90°	1
19	067684-200	3/8 HOSE ASSY X 200 6FJX-6FJX 90°	1
20	067677-112	5/8 HOSE ASSY X 112 10FJX-10FJX 90°	1
21	065234-152	1/4 HOSE ASSY X 152 4FJX-4FJX	1
22	065234-014	1/4 HOSE ASSY X 46.5 4FJX-4FJX	1
23	067687-061	5/8 HOSE ASSY X 61 10FJX90-10FJX90	1
24	065234-032	1/4 HOSE ASSY X 32 4FJX-4FJX	1
25	065234-001	1/4 HOSE ASSY X 20 4FJX-4FJX	1
26	067687-100	5/8 HOSE ASSY X 100 10FJX90-10FJX90	1
27	067685-120	1/2 HOSE ASSY X 120 12MP-10FJX	1
28	067689-022	1/8 HOSE ASSY X 22 2MP-4FJX	1
29	020032-001	FITTING 4MJ-4MJ TEE	REF
30	067758-099	HOSE GUARD - NYLON	REF
32	060861-136	3/8 HOSE ASSY X 136 6FJX-6FJX	1
33	060861-141	3/8 HOSE ASSY X 141 6FJX-6FJX	1
34	060861-102	3/8 HOSE ASSY X 529 6FJX-6FJX	1
35	060861-103	3/8 HOSE ASSY X 370 6FJX-6FJX	2

# Illustrated Parts Breakdown

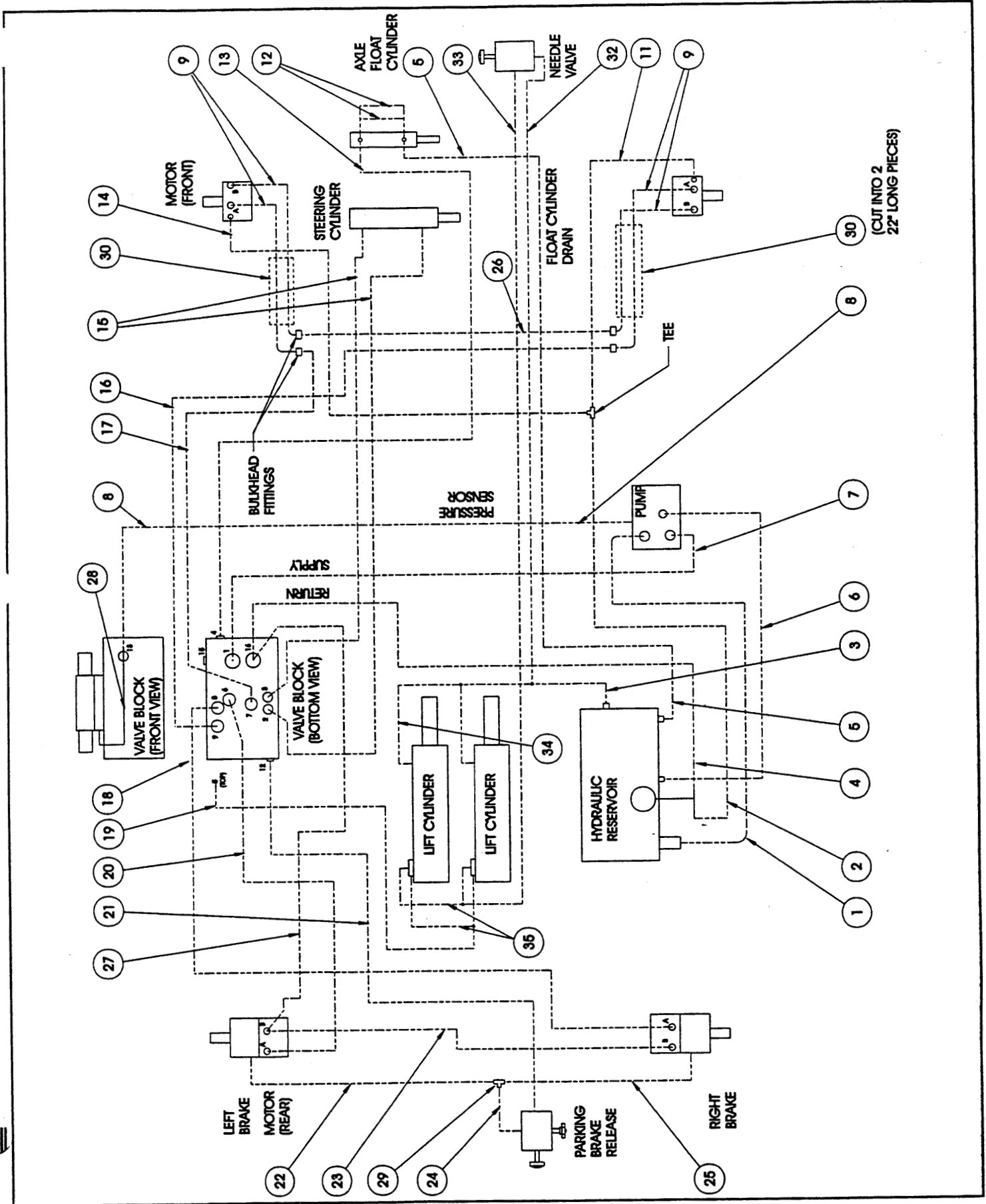

# Illustrated Parts Breakdown

**LABEL KIT, LX50**  
**TWO WHEEL DRIVE**  
 GAS 067532-020, DIESEL 067532-021

ITEM	PART	DESCRIPTION	GAS QTY.	DIESEL QTY.
1	010076-000	MANUAL CASE	1	1
2	010076-001	LABEL-ATTENTION	1	1
3	067903-000	USER MANUAL LX-SERIES	1	1
4	060197-000	LABEL-HYD. FLUID	1	1
5	061205-000	NAME PLATE	1	1
6	061220-001	LABEL-ANSI	1	1
7	060577-000	ANSI MANUAL	1	1
8	064166-000	LABEL-UNLEADED FUEL	1	
9	066552-000	LABEL-WARNING BATTERY	1	1
10	064444-000	LABEL-USA	4	4
11	067642-000	LABEL-CONTROLLER	1	1
12	067638-000	LABEL-MOTOR CONTROLS GAS	1	
12	067638-001	LABEL-MOTOR CONTRLS DIESEL		1
13	067639-000	LABEL-PLATFORM CONTROLS	1	1
14	066550-009	LABEL-DANGER	1	1
15	066551-002	LABEL-CAUTION	1	1
17	30624-024	LABEL-CHOKE	1	
17	67822-000	LABEL-GLOW PLUG		1
19	066554-000	LABEL-READ	1	1
20	066555-000	LABEL-DO NOT ADJUST	1	1
21	063423-000	LABEL-BRAKE RELEASE	1	1
23	061515-000	LABEL-LIFT HERE	1	1
24	066568-000	LABEL-WARNING	1	1
25	027898-000	LABEL-DIESEL FUEL		1
26	066566-000	LABEL-MAX LOAD 1000 LB.	2	2
27	066562-003	LABEL-POLY FILLED TIRES	1	1
28	061683-005	LABEL-UPRIGHT 4 1/2	3	3
29	061683-007	LABEL-UPRIGHT 5 1/2	4	4
30	067644-014	LABEL-LX50 2WD	3	3
31	067644-013	LABEL-LX50 2WD	4	4
33	011248-004	NUT HEX ESNA 1/4-20UNC	4	4
35	011252-008	SCREW HHC 1/4-20UNC X 1	4	4
36	065368-000	TACK	4	4
37	060830-000	SAFETY WALK	4	4
38	066561-001	LABEL, MAINT. BRACE	1	1
39	060086-000	SAFETY WALK 20 X 32	12	12
40	066558-000	LABEL, EMERG. LOWERING	2	2

**LABEL KIT, LX50**  
**FOUR WHEEL DRIVE**  
 GAS 067532-022, DIESEL 067532-023

ITEM	PART	DESCRIPTION	GAS QTY.	DIESEL QTY.
1	010076-000	MANUAL CASE	1	1
2	010076-001	LABEL-ATTENTION	1	1
3	067903-000	USER MANUAL LX-SERIES	1	1
4	060197-000	LABEL-HYD. FLUID	1	1
5	061205-000	NAME PLATE	1	1
6	061220-001	LABEL-ANSI	1	1
7	060577-000	ANSI MANUAL	1	1
8	064166-000	LABEL-UNLEADED FUEL	1	
9	066552-000	LABEL-WARNING BATTERY	1	1
10	064444-000	LABEL-USA	4	4
11	067642-000	LABEL-CONTROLLER	1	1
12	067638-000	LABEL-MOTOR CONTROLS GAS	1	
12	067638-001	LABEL-MOTOR CONTRLS DIESEL		1
13	067639-000	LABEL-PLATFORM CONTROLS	1	1
14	066550-009	LABEL-DANGER	1	1
15	066551-002	LABEL-CAUTION	1	1
17	30624-024	LABEL-CHOKE	1	
17	67822-000	LABEL-GLOW PLUG		1
19	066554-000	LABEL-READ	1	1
20	066555-000	LABEL-DO NOT ADJUST	1	1
21	063423-000	LABEL-BRAKE RELEASE	1	1
23	061515-000	LABEL-LIFT HERE	1	1
24	066568-000	LABEL-WARNING	1	1
25	027898-000	LABEL-DIESEL FUEL		1
26	066566-000	LABEL-MAX LOAD 1000 LB.	2	2
27	066562-003	LABEL-POLY FILLED TIRES	1	1
28	061683-005	LABEL-UPRIGHT 4 1/2	3	3
29	061683-007	LABEL-UPRIGHT 5 1/2	4	4
30	067644-016	LABEL-LX50 4WD	3	3
31	067644-015	LABEL LX50 4WD	4	4
33	011248-004	NUT HEX ESNA 1/4-20UNC	4	4
35	011252-008	SCREW HHC 1/4-20UNC X 1	4	4
36	065368-000	TACK	4	4
37	060830-000	SAFETY WALK	4	4
38	066561-001	LABEL, MAINT. BRACE	1	1
39	060086-000	SAFETY WALK 20 X 32	12	12
40	066558-000	LABEL, EMERG. LOWERING	2	2

# Illustrated Parts Breakdown

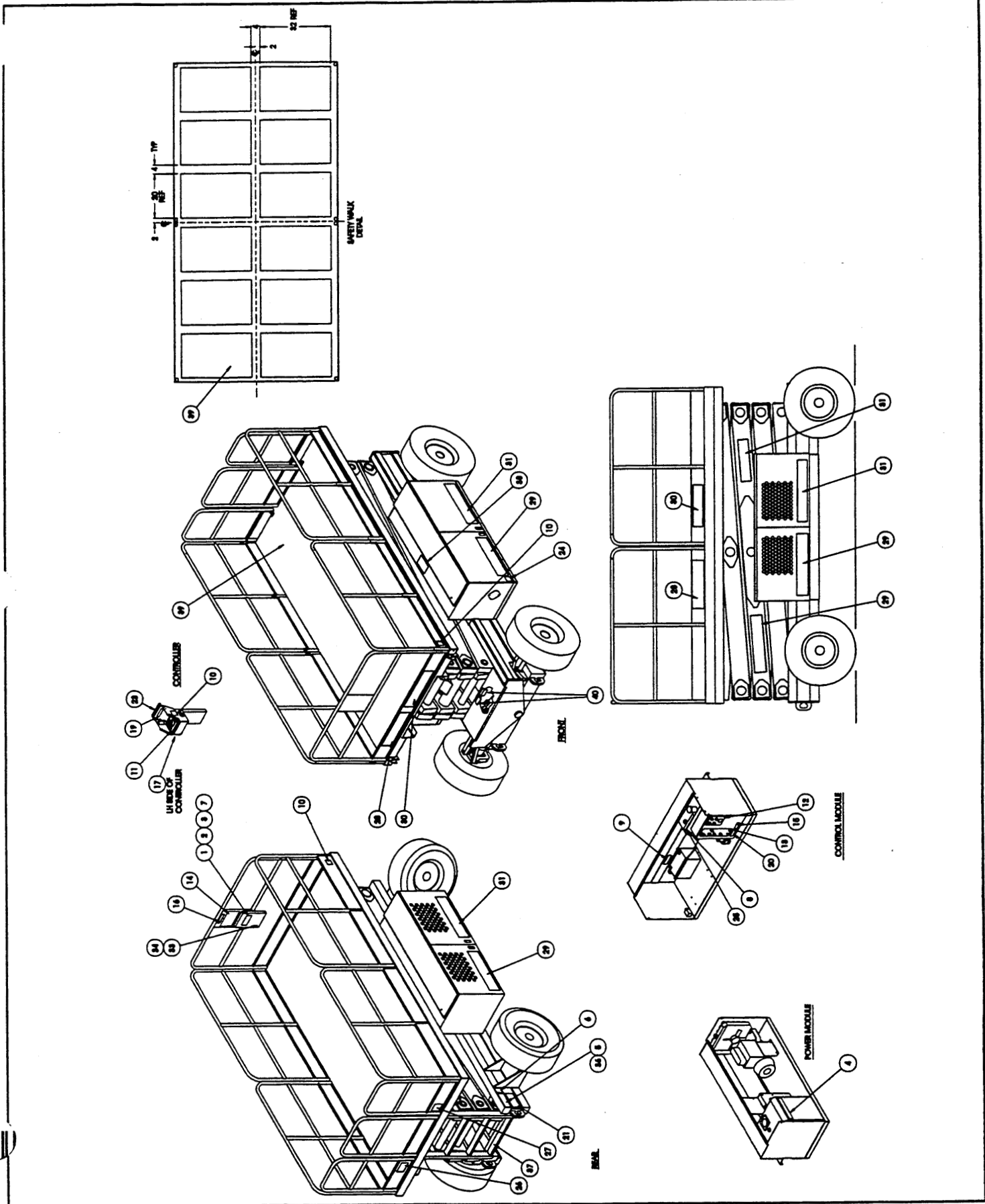

# Illustrated Parts Breakdown

**LABEL KIT, LX50 DUAL DECK**  
**TWO WHEEL DRIVE**  
 GAS 067532-038, DIESEL 067532-039

ITEM	PART	DESCRIPTION	GAS QTY.	DIESEL QTY.
1	010076-000	MANUAL CASE	1	1
2	010076-001	LABEL-ATTENTION	1	1
3	067903-001	USER MANUAL LX-SERIES	1	1
4	060197-000	LABEL-HYD. FLUID	1	1
5	061205-000	NAME PLATE	1	1
6	061220-001	LABEL-ANSI	1	1
7	060577-000	ANSI MANUAL	1	1
8	064166-000	LABEL-UNLEADED FUEL	1	
9	066552-000	LABEL-WARNING BATTERY	1	1
10	064444-000	LABEL-USA	4	4
11	067642-000	LABEL-CONTROLLER	1	1
12	067638-000	LABEL-MOTOR CONTRLS GAS	1	
12	067638-001	LABEL-MOTOR CONTRLS DIESEL		1
13	067639-000	LABEL-PLATFORM CONTROLS	1	1
14	066550-009	LABEL-DANGER	1	1
15	066551-002	LABEL-CAUTION	1	1
17	30624-024	LABEL-CHOKE	1	
17	67822-000	LABEL-GLOW PLUG		1
19	066554-000	LABEL-READ	1	1
20	066555-000	LABEL-DO NOT ADJUST	1	1
21	063423-000	LABEL-BRAKE RELEASE	1	1
22	066562-003	LABEL-POLY FILLED TIRES	1	1
23	061515-000	LABEL-LIFT HERE	1	1
24	066568-000	LABEL-WARNING	1	1
25	027898-000	LABEL-DIESEL FUEL		1
26	066557-000	LABEL-MAX LOAD 750 LB.	2	2
27	061683-004	LABEL-UPRIGHT 2-1/2	1	1
28	061683-005	LABEL-UPRIGHT 4 1/2	2	2
29	061683-007	LABEL-UPRIGHT 5 1/2	3	3
30	067644-019	LABEL-LX50 2WD	5	5
31	067644-013	LABEL-LX50 2WD	1	1
33	011248-004	NUT HEX ESNA 1/4-20UNC	4	4
35	011252-008	SCREW HHC 1/4-20UNC X 1	4	4
36	065368-000	TACK	4	4
37	060830-000	SAFETY WALK	4	4
38	066561-001	LABEL, MAINT. BRACE	1	1
39	060086-000	SAFETY WALK 20 X 32	12	12
40	066558-000	LABEL, EMERG. LOWERING	2	2

**LABEL KIT, LX50 DUAL DECK**  
**FOUR WHEEL DRIVE**  
 GAS 067532-040, DIESEL 067532-041

ITEM	PART	DESCRIPTION	GAS QTY.	DIESEL QTY.
1	010076-000	MANUAL CASE	1	1
2	010076-001	LABEL-ATTENTION	1	1
3	067903-001	USER MANUAL LX-SERIES	1	1
4	060197-000	LABEL-HYD. FLUID	1	1
5	061205-000	NAME PLATE	1	1
6	061220-001	LABEL-ANSI	1	1
7	060577-000	ANSI MANUAL	1	1
8	064166-000	LABEL-UNLEADED FUEL	1	
9	066552-000	LABEL-WARNING BATTERY	1	1
10	064444-000	LABEL-USA	4	4
11	067642-000	LABEL-CONTROLLER	1	1
12	067638-000	LABEL-MOTOR CONTRLS GAS	1	
12	067638-001	LABEL-MOTOR CONTRLS DIESEL		1
13	067639-000	LABEL-PLATFORM CONTROLS	1	1
14	066550-009	LABEL-DANGER	1	1
15	066551-002	LABEL-CAUTION	1	1
17	30624-024	LABEL-CHOKE	1	
17	67822-000	LABEL-GLOW PLUG		1
19	066554-000	LABEL-READ	1	1
20	066555-000	LABEL-DO NOT ADJUST	1	1
21	063423-000	LABEL-BRAKE RELEASE	1	1
22	066562-003	LABEL-POLY FILLED TIRES	1	1
23	061515-000	LABEL-LIFT HERE	1	1
24	066568-000	LABEL-WARNING	1	1
25	027898-000	LABEL-DIESEL FUEL		1
26	066557-000	LABEL-MAX LOAD 750 LB.	2	2
27	061683-004	LABEL-UPRIGHT 2-1/2	1	1
28	061683-005	LABEL-UPRIGHT 4 1/2	2	2
29	061683-007	LABEL-UPRIGHT 5 1/2	3	3
30	067644-020	LABEL-LX50 4WD	5	5
31	067644-015	LABEL LX50 4WD	1	1
33	011248-004	NUT HEX ESNA 1/4-20UNC	4	4
35	011252-008	SCREW HHC 1/4-20UNC X 1	4	4
36	065368-000	TACK	4	4
37	060830-000	SAFETY WALK	4	4
38	066561-001	LABEL, MAINT. BRACE	1	1
39	060086-000	SAFETY WALK 20 X 32	12	12
40	066558-000	LABEL, EMERG. LOWERING	2	2

# Illustrated Parts Breakdown

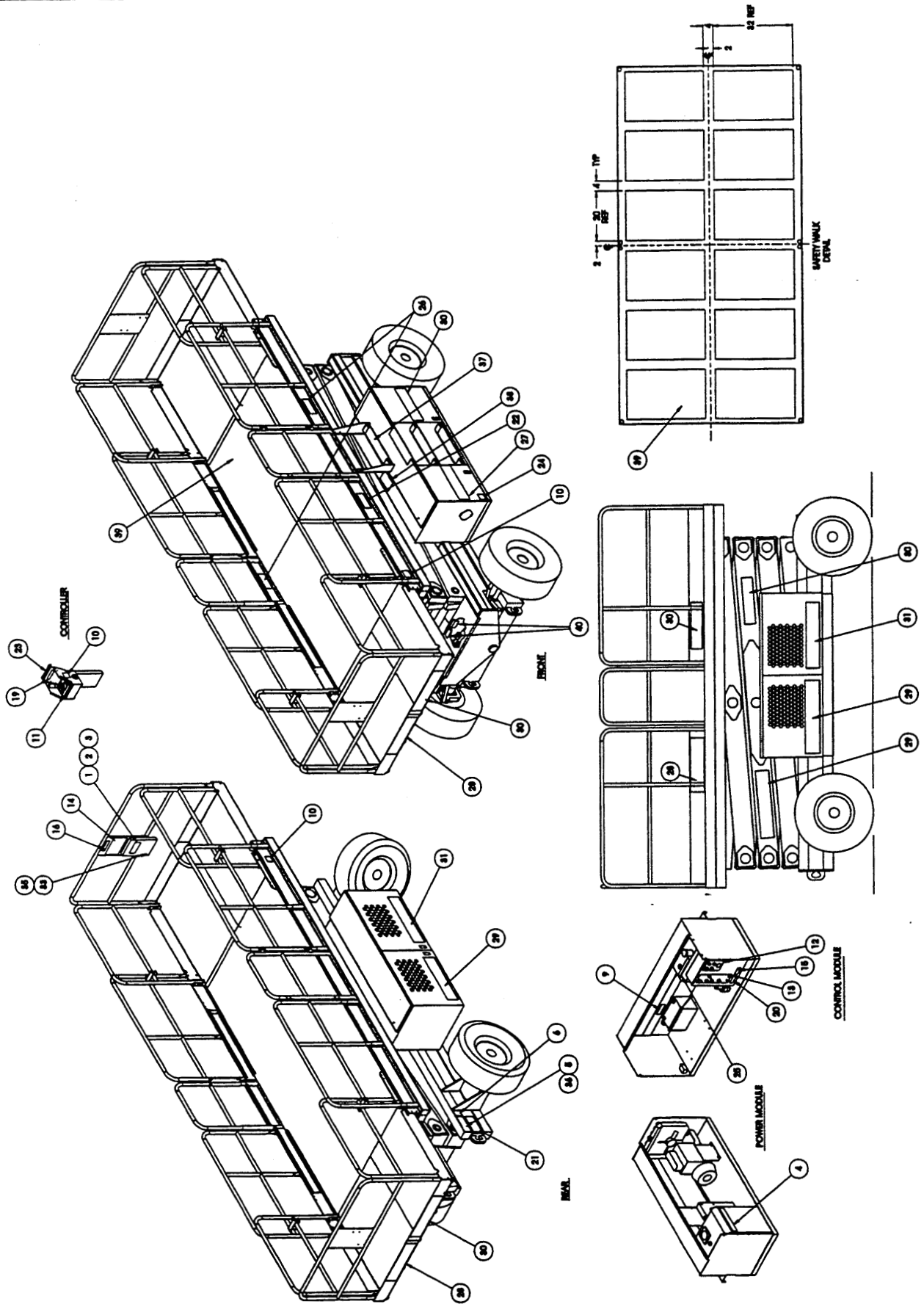

# Illustrated Parts Breakdown

## DUAL FUEL ASSEMBLY

LX50 STANDARD, 067905-000

LX50 DUAL DECK, 067905-001

ITEM	PART	DESCRIPTION	QTY.
1	067615-051	GASOLINE SHUT-OFF VALVE(LP-1)	1
2		FILTER(LP-2)	1
3		SOLENOID(LP-3)	1
4	067615-052	SOLENOID/FILTER(LP-2)	1
5	067615-055	REGULATOR / VAPORIZER(LP-5)	1
6	067615-056	FTG, 1/8 MPT - 1/4 HOSE BARB	1
7	067615-057	FTG, 90° STREET EL 1/4 PIPE	1
8	067615-058	FTG, 90° ELBOW 4 MPT - 6 MJ	2
9	067615-059	FTG, 90° 6 MPT - 5/16 HOSE BARB	2
10	067615-060	1/2" DIA. LP HOSE X 17" LG.	1
11	067615-060	1/4" DIA. HOSE X 23" LG.	1
12		1/4" DIA. HOSE X 13" LG.	1
13	067615-063	5/16 DIA. HOSE X 15" LG.	1
14	067615-064	HOSE CLAMP 5/16"	10
15	067615-065	HOSE CLAMP 1/2"	2
17	067615-067	FTG, STR 8 MPT -1/2 HOSE BARB	1
18		FTG, 90° 4 MPT - 4 MPT	1
19	067615-069	FTG, STR. 2 NPT - 5/16 HOSE BARB	2
20	067615-070	FEMALE ADAPTER (PROPANE TANK)	1

ITEM	PART	DESCRIPTION	QTY.
21	067615-073	FTG, STR 2MP-6MJ BRASS	1
22	067615-075	RELIEF VALVE 400 PSI	1
23	067615-074	FTG, 2-2-2 STR TEE BRASS	1
25	067615-049	HOSE ASSY X 100	1
26	064189-001	DECAL	1
27	011248-006	LOCKNUT 3/8-16 UNC ESNA	4
28	011254-008	SCRW, HHC 3/8-16 UNC X 1	4
29	027823-000	TANK MOUNTING BRACKET	1
30	027934-003	FUEL TANK, PROPANE	21
30	027934-009	FUEL TANK, PROPANE - DUAL DECK	1
31	064421-000	DECAL	1
32	011252-006	SCRW, HHC 1/4-20 UNC X 3/4	2
33	011248-004	LOCKNUT, 1/4-20 UNC ESNA	2
101	067660-001	TERM BLOCK (TAN)	1
102	064443-001	CONTACT BLOCK N.O.	1
103	029616-002	TERMINAL, FEMALE PUSH 16-14GA .25	1
104	029610-006	CONN FORK 16-14GA. #6	2
105	029601-011	TERMINAL, RING 16-14GA. #6	2
106	029452-099	WIRE, 16 AWG BLACK	FT13

67905-000  
STANDARD

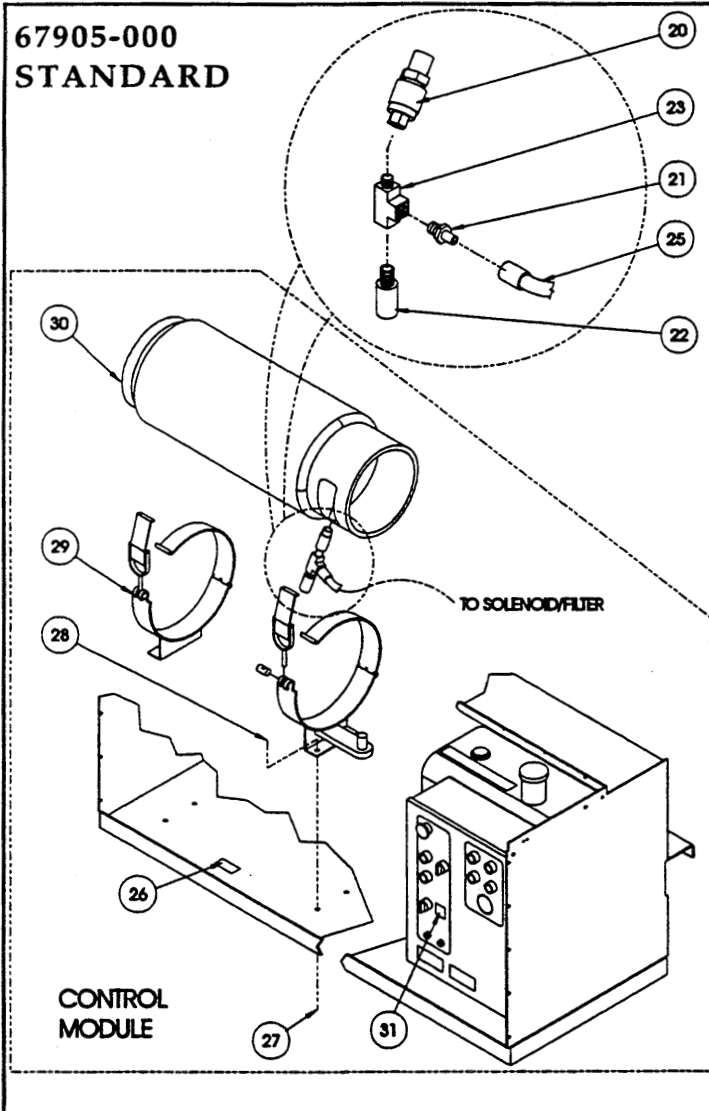

67905-001  
DUAL DECK

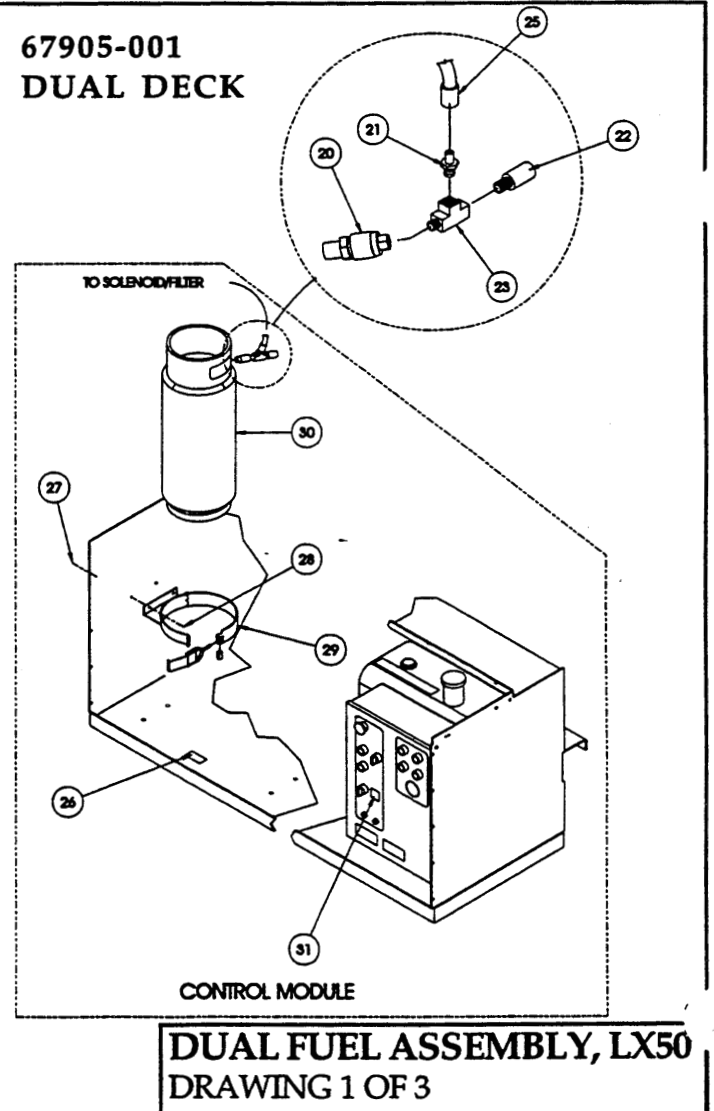

DUAL FUEL ASSEMBLY, LX50  
DRAWING 1 OF 3

NOTE  
1. ITEM #41 SOLIDROUNDER OR ITEM #2 & #3 (EARTHCON SOLENOID & RUBER) MAY BE SUPPLIED WITH KIT.  
2. SPRINGS ON WHICH SOLIDROUNDER IS SUPPLIED WITH KIT, HALF PIPE ELBOW (ITEM 16) OR STREET ELBOW (ITEM 7) WILL BE USED. THE OTHER PART WILL BE EXCESS.

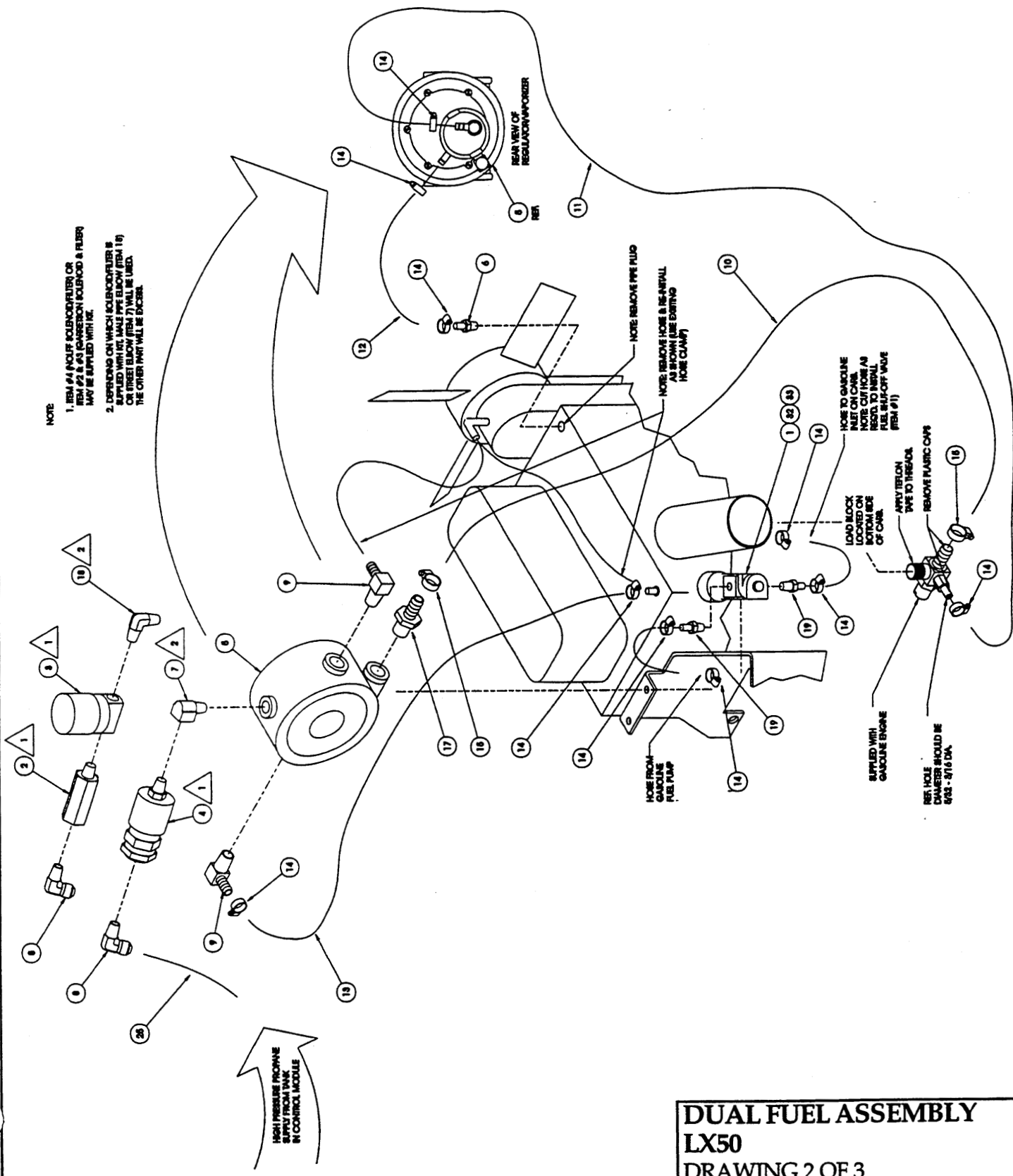

**DUAL FUEL ASSEMBLY  
LX50  
DRAWING 2 OF 3**



# Illustrated Parts Breakdown

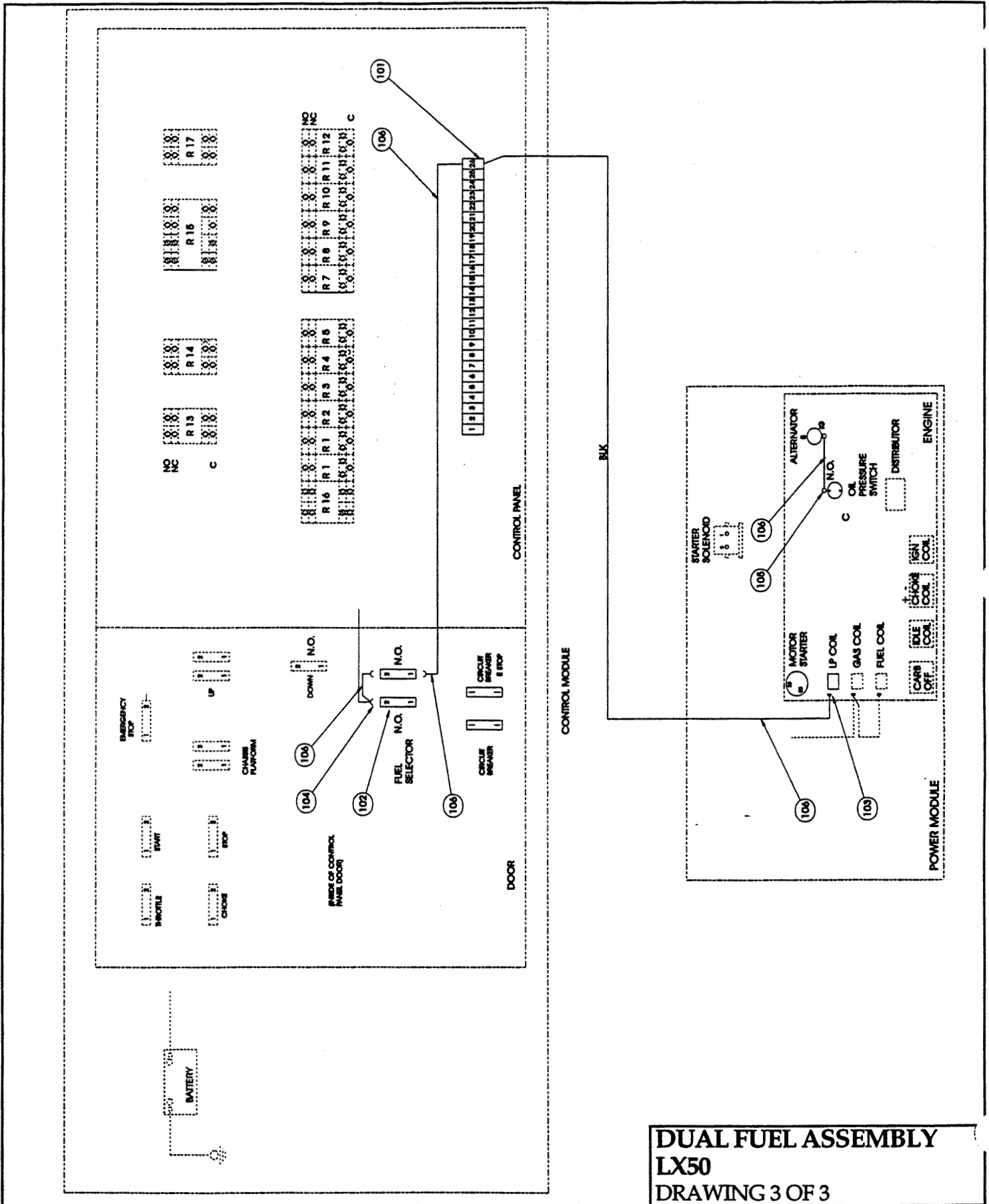

**DUAL FUEL ASSEMBLY  
LX50  
DRAWING 3 OF 3**

NOTES:

# Illustrated Parts Breakdown

**GENERATOR OPTION, LX**  
**DUAL FUEL**  
 067848-000

ITEM	PART	DESCRIPTION	QTY.
1	REF	MODULE TRAY WELDMENT	REF
2	REF	FUEL TANK	REF
3	REF	ENGINE	REF
4	027979-000	GENERATOR	1
5	064212-000	CORD ASSY	1
6	063949-045	SHEAVE, WOODS AK46 WITH 5/8 BORE	1
7	011675-070	V-BELT 4L370	1
8	067528-000	CONTROLLER	REF
9	012797-000	SWITCH, TOGGLE	1
10	008271-000	SWITCH GUARD	1
11	064211-000	DECAL, ON-OFF	1
12	011254-010	BOLT 3/8-16 X 1 1/4	10
13	011248-006	ESNT 3/8-16	10
14	064793-000	RADIATOR BRACKET	1
15	065916-000	MOUNTING PLATE, GENERATOR	1

ITEM	PART	DESCRIPTION	QTY.
16	029610-004	CONN FORK 16-14 #10	3
17	029825-002	DIODE, 3 AMP	1
18	029620-002	CONN, BUTT 16 GA	1
19	029483-099	WIRE 16 GA RED/WHT	1 FT
20	063956-002	PIN, MALE CONTACT	1
21	029454-099	WIRE, 16 GA	1 FT
22	067907-000	POWER TO PLATFORM OPT. (NOT SHOWN)	REF.
23	063969-001	PULLEY, IDLER	1
24	063969-002	PULLEY MOUNT, ECCENTRIC	1
25	011266-008	SCREW HHC 1/2-20 UNF X 1	1
26	064792-000	IDLER BRACKET	1
27	064791-000	SHEAVE	1
28	063961-030	SCREW HHC M8-1.25 X 30	3
29	011238-005	WASHER 5/16 SPLIT LOCK	3
30	011240-006	WASHER 3/8 FLAT	10

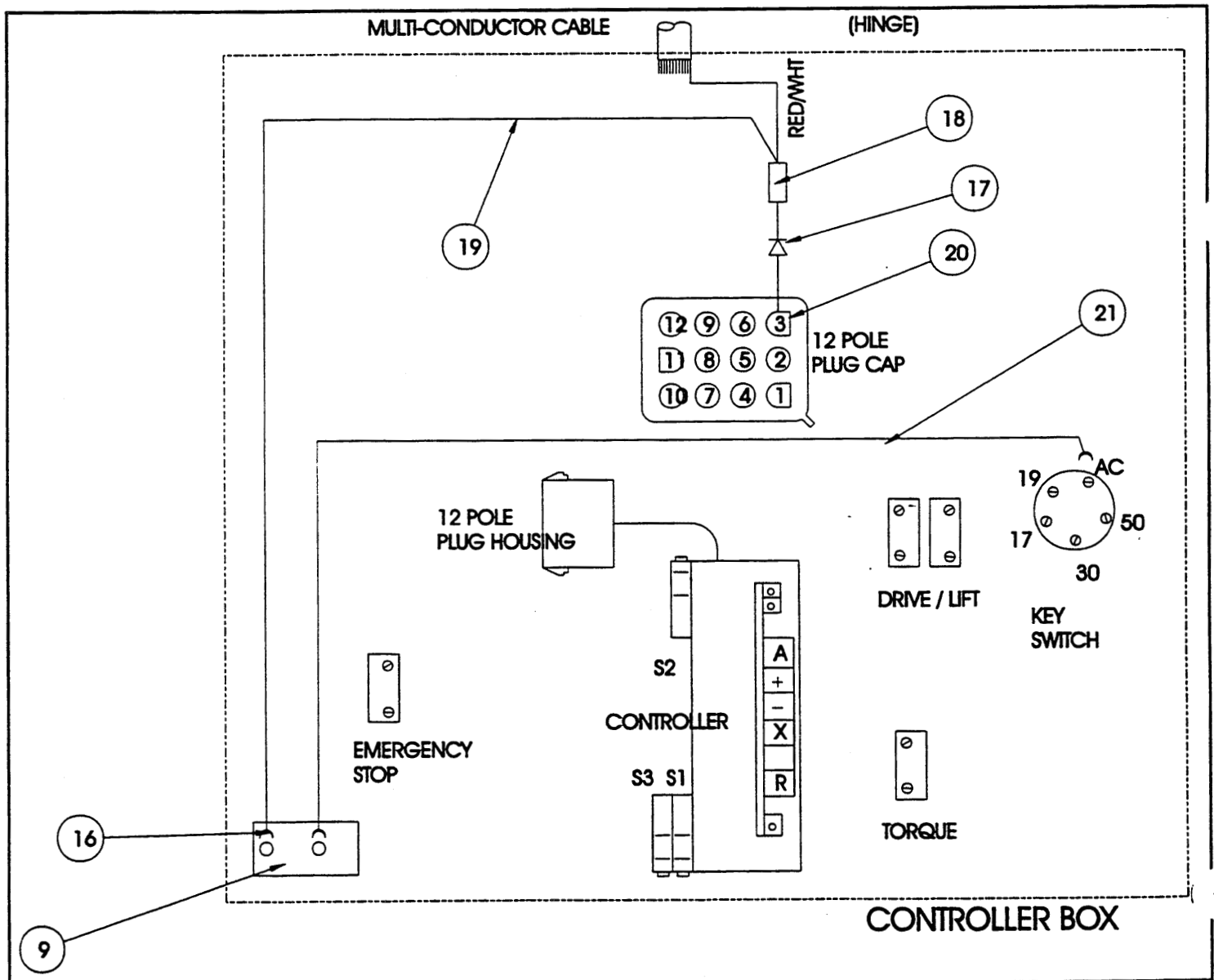

# Illustrated Parts Breakdown

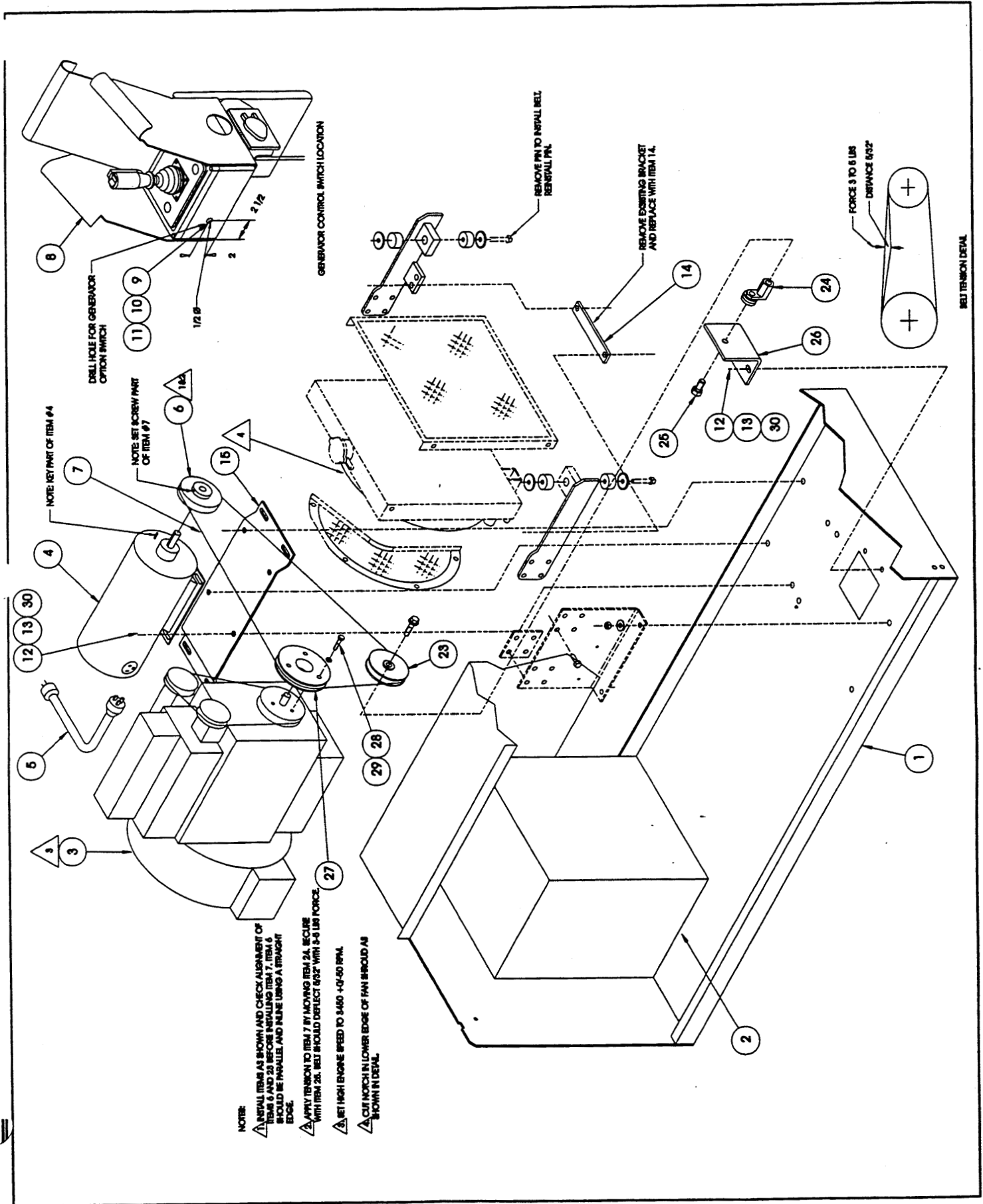

# Illustrated Parts Breakdown

## GENERATOR OPTION, LX

DIESEL

067849-000

ITEM	PART	DESCRIPTION	QTY.
1	REF	MODULE TRAY WELDMENT	REF
2	REF	FUEL TANK	REF
3	067614-000	ENGINE	REF
4	027979-000	WINCO GENERATOR	1
5	064212-000	CORD ASSY	1
6	063949-042	SHEAVE, GENERATOR- WOODS AC 40- 5/8 BORE	1
7	011994-011	V-BELT 3L-360	1
8	067528-001	CONTROLLER	REF
9	012797-000	SWITCH, TOGGLE	1
10	008271-000	SWITCH GUARD	1
11	064211-000	DECAL, ON-OFF	1
12	011254-010	BOLT 3/8-16 X 1 1/4	10
13	011248-006	ESNT 3/8-16	10
14	067614-021	DUAL SHEAVE - KUBOTA #17213-74281	1

ITEM	PART	DESCRIPTION	QTY.
15	065916-000	MOUNTING PLATE, GENERATOR	1
16	029610-004	CONN FORK 16-14 #10	3
17	029825-002	DIODE, 3 AMP	1
18	029620-002	CONN, BUTT 16 GA	1
19	029483-099	WIRE 16 GA, RED WHT	1 FT
20	063956-002	PIN, MALE CONTACT	1
21	029454-099	WIRE, 16 GA RED	1 FT
22	067907-000	POWER TO PLATFORM OPT. (NOT SHOWN)	REF
23	063969-001	PULLEY, IDLER	1
24	063969-002	PULLEY MOUNT, ECCENTRIC	1
25	064792-000	IDLER BRACKET	1
26	011266-008	SCREW HHC 1/2-20 UNF X 1	1
27	011240-006	WASHER 3/8 FLAT	10

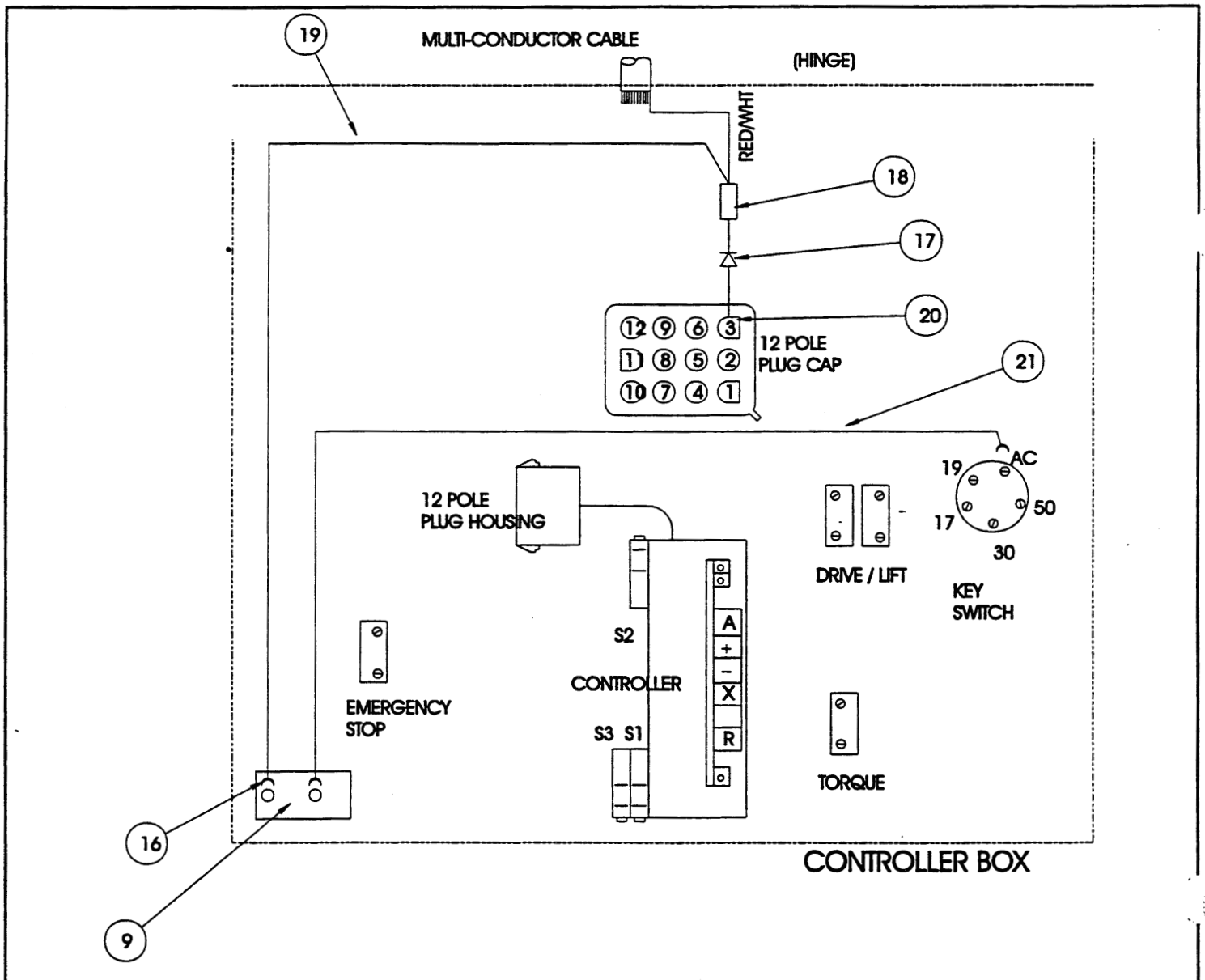

# Illustrated Parts Breakdown

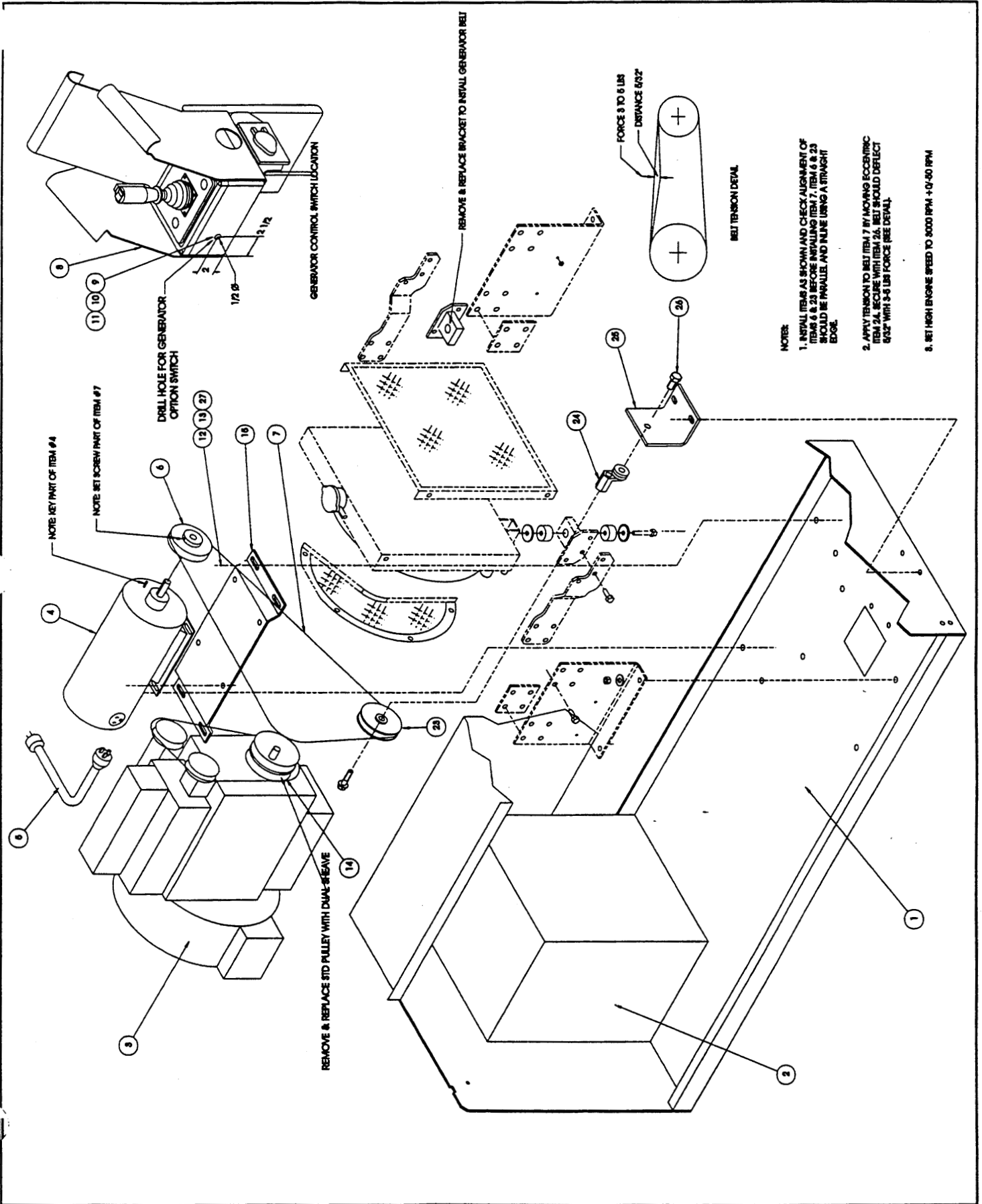

- NOTE:
1. INSTALL ITEM AS SHOWN AND CHECK ALIGNMENT OF ITEM 6 & 23 BEFORE INSTALLING ITEM 7. ITEM 6 & 23 SHOULD BE PARALLEL AND IN LINE USING A STRAIGHT EDGE.
  2. APPLY TENSION TO BELT ITEM 7 BY MOVING ECCENTRIC ITEM 24. SECURE WITH ITEM 25. BELT SHOULD DEFLECT 5/32" WITH 3-6 LBS FORCE (SEE DETAIL).
  3. SET HIGH ENGINE SPEED TO 3000 RPM +/- 40 RPM

**REMOVABLE CONTROLLER OPTION  
LX50  
061898-002**

ITEM	PART	DESCRIPTION	QTY.
1	028800-003	PLUG CONNECTOR (FEMALE)	1
2	028800-004	PIN CONTACT (MALE)	15
3	028800-015	PLUG SEALING	16
4	028800-016	RECEPTACLE CONNECTR W/ CLAMP (MALE)	1
5	028800-005	SOCKET CONTACT (FEMALE)	15
8	030719-001	110 VAC BRACKET	1
10	011254-020	SCREW HHC GRD5 3/8-16UNC X 2 1/2	2
11	011240-006	WASHER 3/8 STD FLAT	4
12	011248-006	NUT HEX ESNA 3/8-16	2
13	068761-000	LOCKING WEDGE-CONN	1
14	068760-001	CONNECTOR-RECEPTACLE	1
15	068762-000	PIN-CONTACT	9
16	068761-001	LOCKING WEDGE -CONN	1
17	068760-000	PLUG - CONNECTOR	1
18	068762-001	SOCKET-CONTACT	9
19	068764-000	PLUG-CONNECTOR	6
20	068908-000	BOOT ELECT. PLUG	1
21	068908-001	BOOT ELECT. RECEPTACLE	1

Items 8 through 12 see note 10.

Items 13 through 21 see note 11.

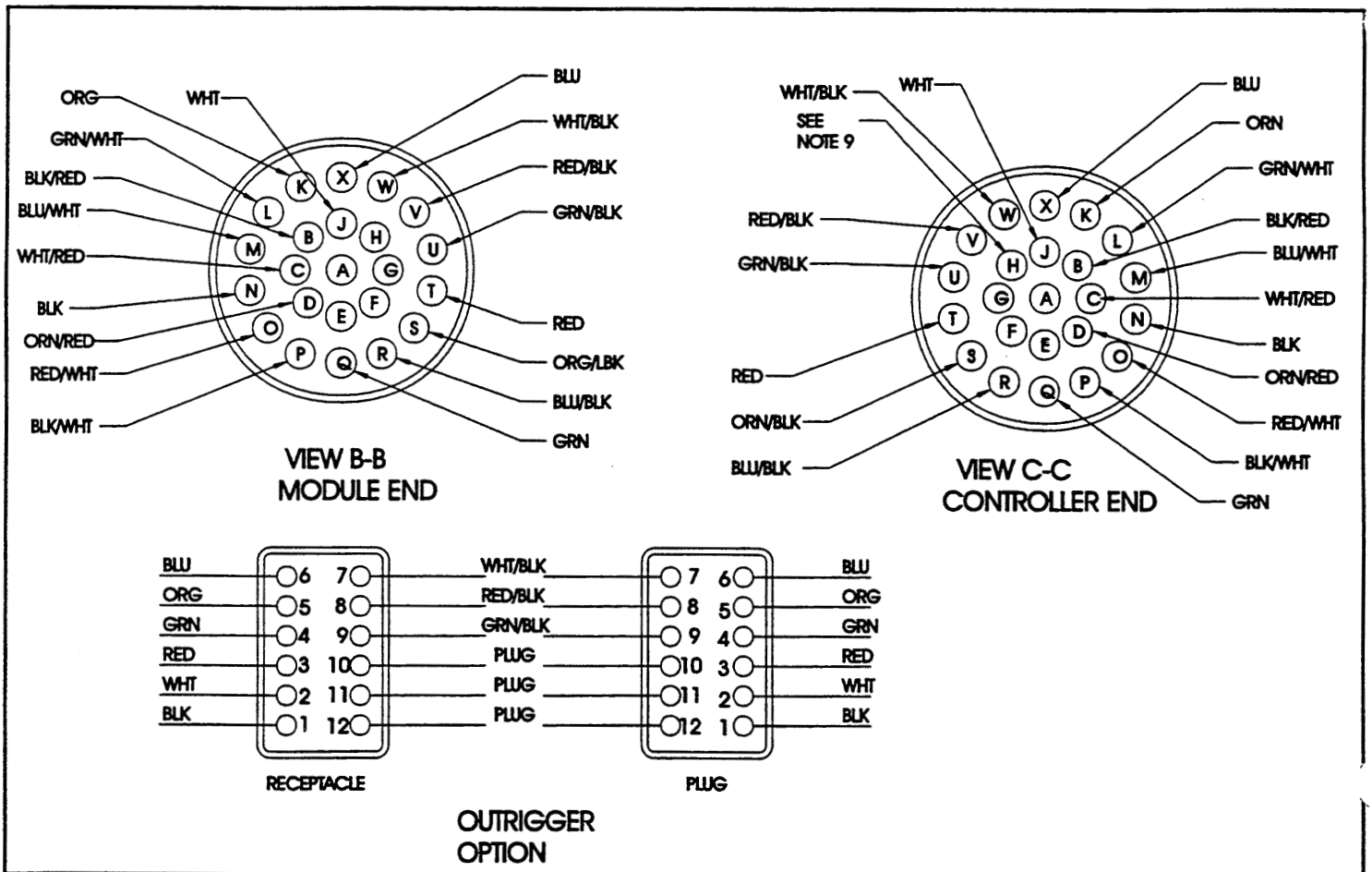

# Illustrated Parts Breakdown

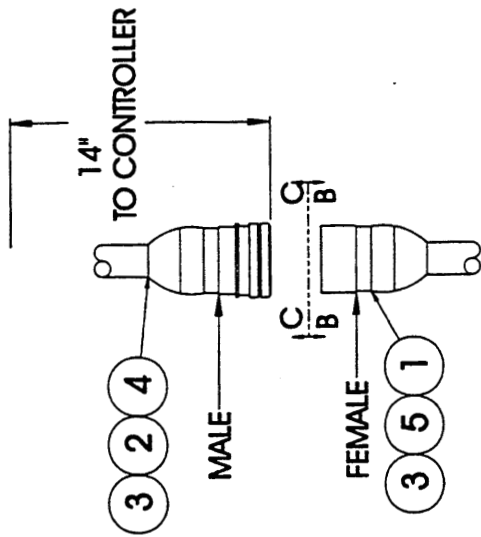

1. CUT OFF CONTROL CABLE 14 INCHES BELOW STRAIN RELIEF ON CONTROLLER.
2. CUT OUTER CABLE COVER OF LINKAGE CABLE BACK APPROXIMATELY 1-1/2 INCH AND STRIP APPROXIMATELY 1/4 INCH OF EACH END.
3. CRIMP SOCKETS (28800-005) ONTO WIRE ENDS AND INSERT INTO CONNECTOR (28800-016). REF. VIEW B-B.
4. CUT OUTER CABLE COVER OF CONTROLLER END BACK APPROXIMATELY 1-1/2 INCH AND STRIP APPROXIMATELY 1/4 INCH OF EACH END.
5. SLIDE BOOT AND CLAMP ONTO CABLE.
6. CRIMP PINS (28800-004) ONTO WIRE ENDS AND INSERT INTO CONNECTOR (28800-003). REF. VIEW C-C.
7. CLAMP BOOT TO CONNECTOR.
8. CONNECT CONTROLLER AND TEST MACHINE FOR PROPER FUNCTION.
9. USE TERMINAL "H" FOR HORN OPTION OR IF AUX WIRE IS REQUIRED.
10. ITEM #8 THRU 12 REQD ONLY FOR 110 VAC.
11. ITEM # 13 THRU 21 REQD ONLY OUTRIGGER OPTION.

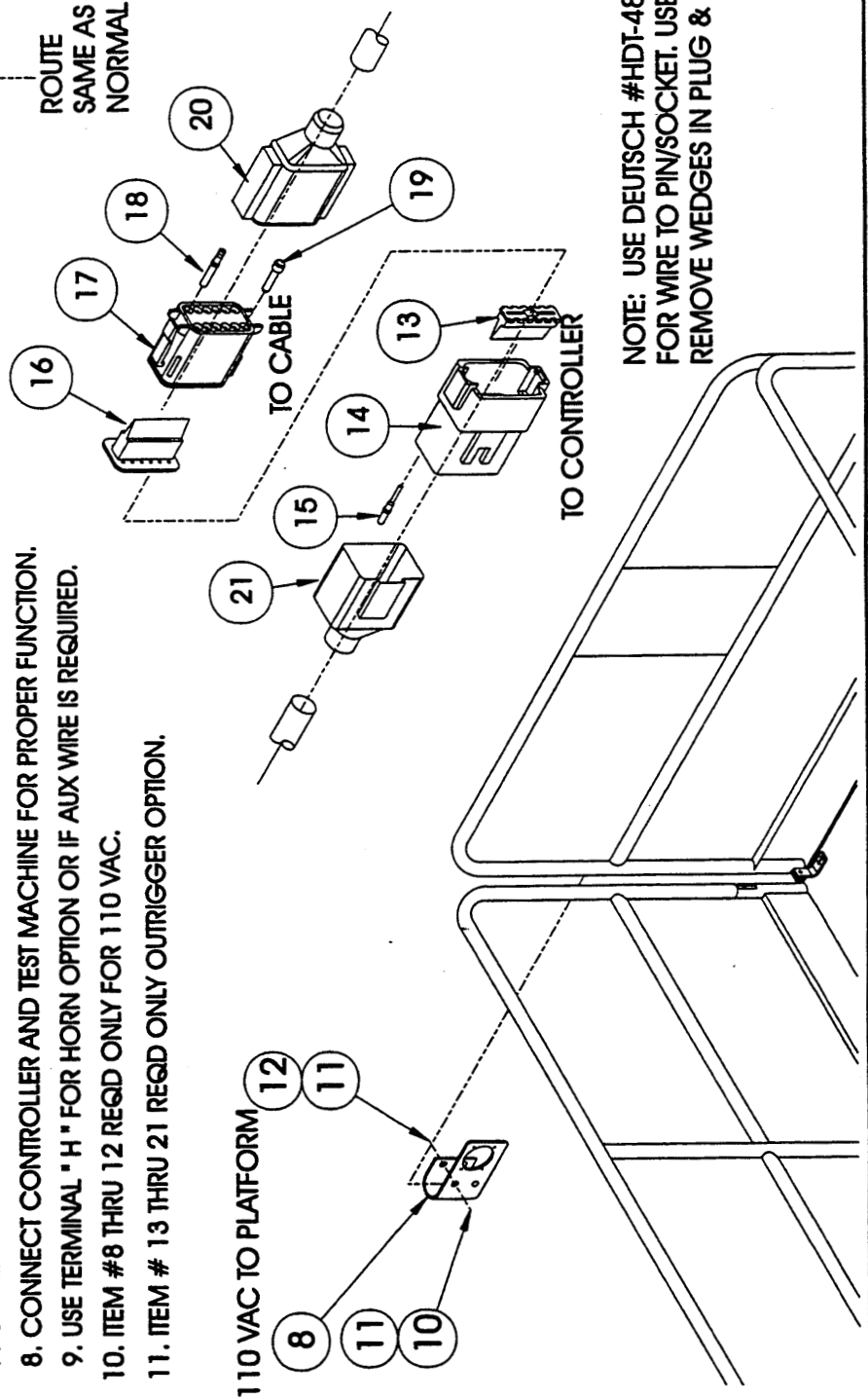



## HORN OPTION

LX50

067908-000

ITEM	PART	DESCRIPTION	QTY.
1	011252-008	SCREW HHC 1/4-20 X 1	2
2	011248-004	NUT HEX 1/4-20	2
3	029452-099	WIRE 16 GA BLACK	FT75
5	029610-002	CONNECTOR FORK	3
6	029601-014	CONNECTOR RING	1
7	029615-002	CONNECTOR PUSH	2
8	029958-001	HORN 24VDC	1
9	063917-000	SWITCH PUSHBUTTON	1

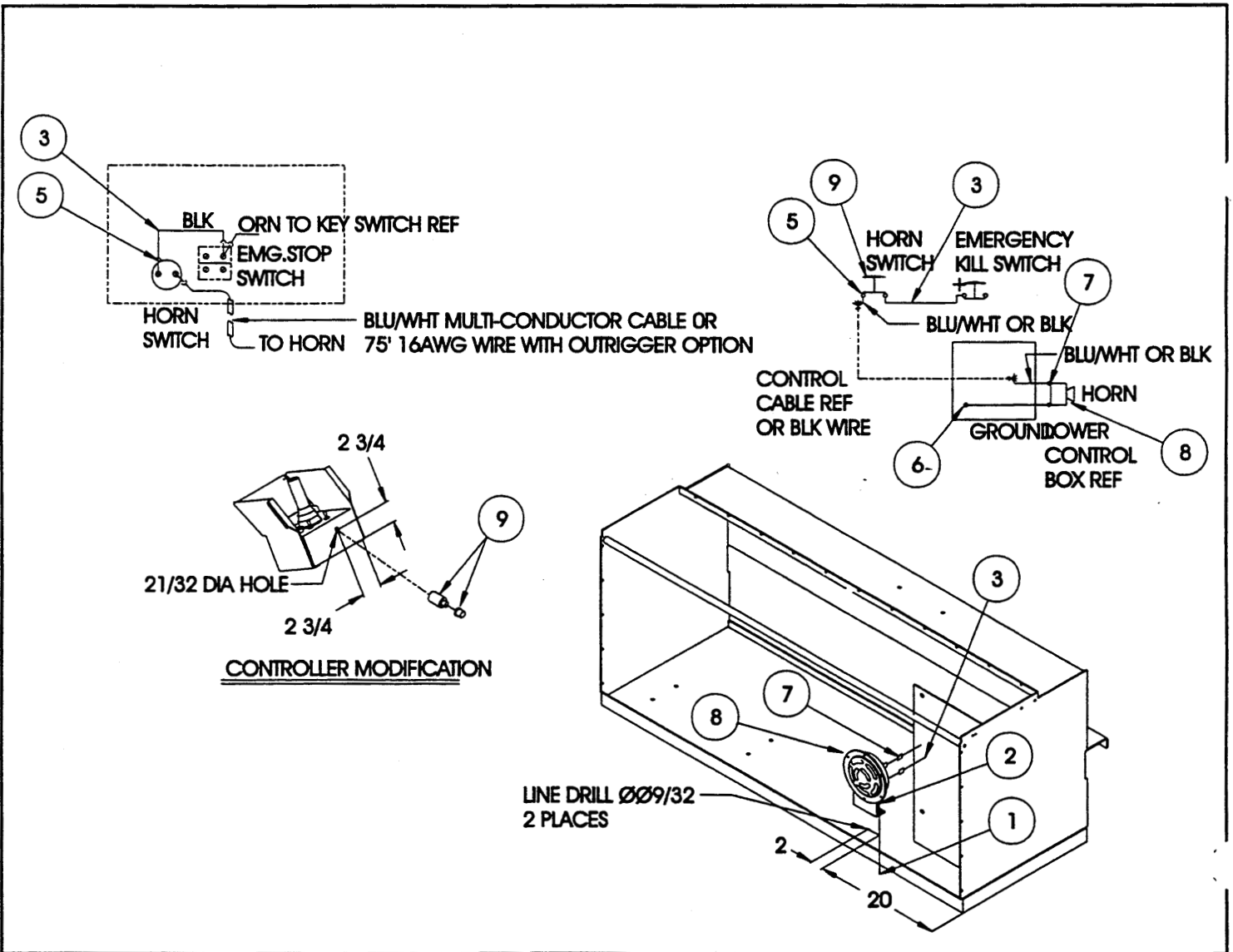

# Illustrated Parts Breakdown

## AMBER BEACON OPTION

\_X50

067947-000

ITEM	PART	DESCRIPTION	QTY.
1	012848-004	LIGHT 12-24 VOLT	2
2	063193-000	LIGHT BRACKET	2
3	029702-000	FUSE HOLDER	1
4	029704-002	FUSE 2 AMP	1
5	029610-002	CONN FORK 16-14 #8	1
6	029601-013	CONN RING 16-14 #10	1
7	029620-002	CONN BUTT 16-14	4
8	029496-099	WIRE 16 AWG 2 COND	FT18
9	011249-003	NUT HEX ESNA #10-32	4
10	011826-004	SCREW MACH.RD.HD. #10-32 X 1/2	4

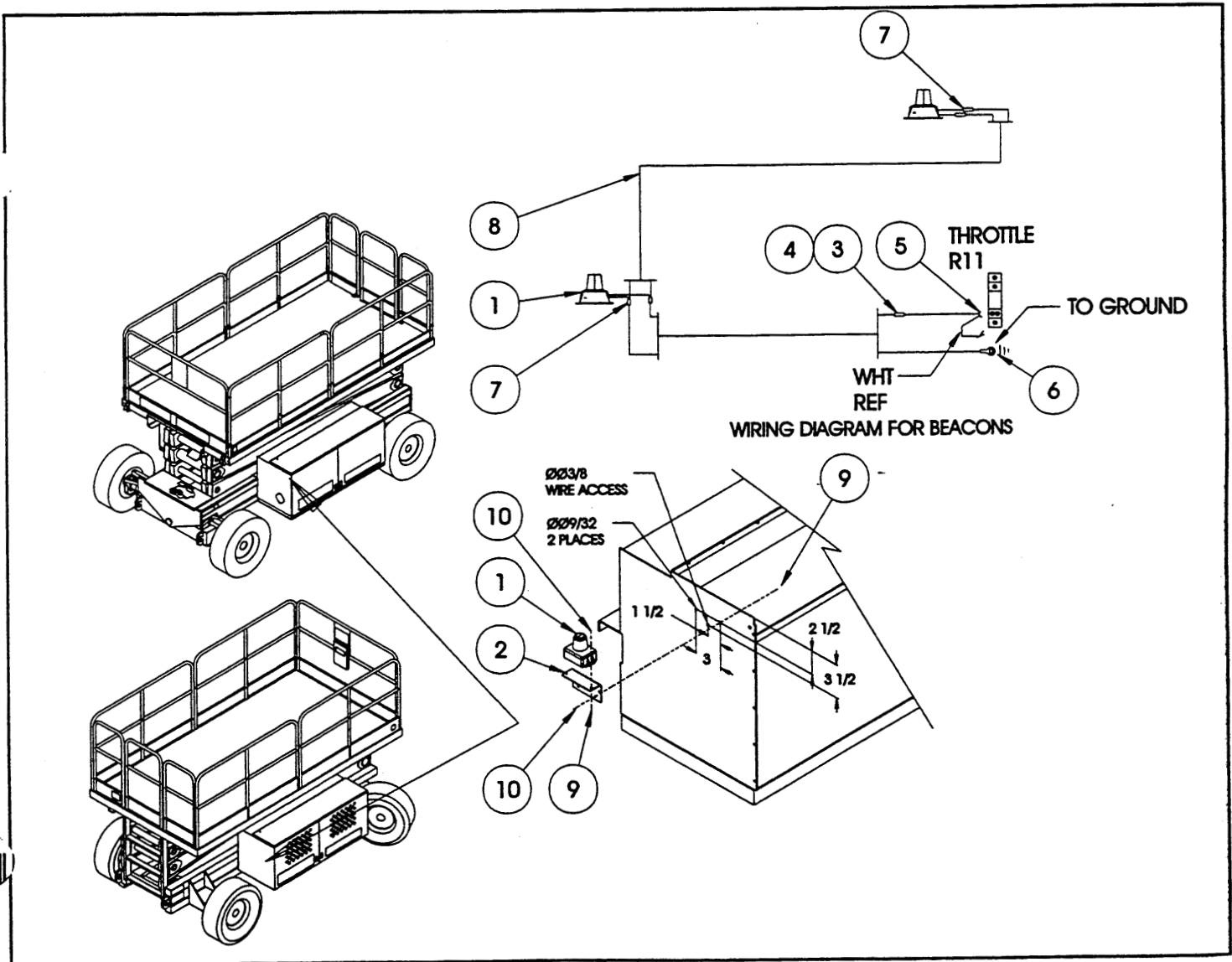

## POWER TO PLATFORM OPTION

LX50

067907-000

ITEM	PART	DESCRIPTION	QTY.
1	011715-006	SCREW, RD HD 6-32 X 3/4 LG	10
2	008942-001	OUTLET	1
3	064520-000	POWER BRACKET	1
4	029495-099	WIRE 14 GA 3-COND	84FT
5	REF	CONTROLLER	REF
7	029961-000	INLET PLUG	1
6	REF	CONTROL MODULE	1
8	029961-001	SEAL, INLET PLUG	2
9	029962-000	ELEC BOX COVER	1
10	011248-047	NUT #6-32 ESNA	10
11	068639-000	LABEL-POWER TO PLATFORM	1

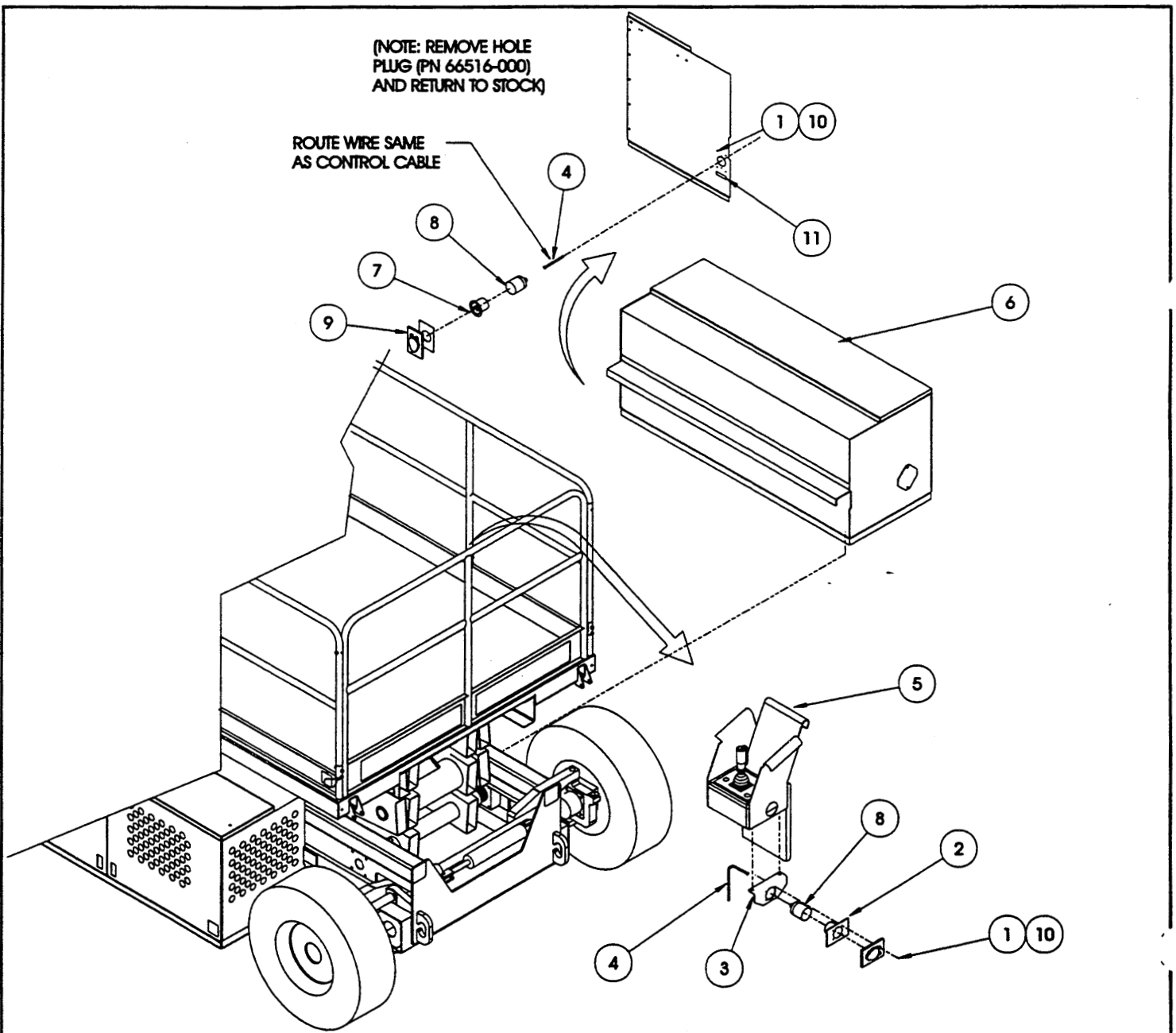

NOTES:

# Illustrated Parts Breakdown

## OUTRIGGER OPTION

LX50

067950-000

ITEM	PART	DESCRIPTION	QTY.
1	067844-000	OUTRIGGER SUPPORT WELDMENT	4
2	067840-000	OUTRIGGER CYL.	4
3	067957-000	CONTROL MODULE ASSY	1
4	064794-000	LEVEL MOUNT	1
5	067954-000	CONTROLLER ASSY	1
6	011240-008	WASHER 1/2 STD FLAT	32
7	011246-008	NUT HEX ESNA 1/2-13 UNC	16
8	011256-020	SCREW HHC 1/2-13UNC X 2 1/2	16
9	062881-000	SWITCH BALL	4
10	063921-006	SWITCH PRESS.	4
11	066516-004	PLUG	4
12	064462-002	GROMMET, CAPLUG #GRO-1/2-UL	4
13	011941-005	FITTING 6MB-6MJ	4
14	011934-004	FITTING 6MBH-6MJ 90	4
15	011937-003	FITTING 6FJX-6MJ 90	4
16	066556-001	LABEL CAUTION	4
17	067642-001	LABEL CONTROLLER	1
18	066551-003	LABEL TIPPING	1
20	067953-000	HOSE KIT / INST. (NOT SHOWN)	1
21	014924-008	U-BOLT	2
22	011248-004	NUT HEX 1/4-20 ESNA	4
23	005133-000	SPRING	3
24	000942-000	ORBIT LEVEL	1
25	011721-008	SCREW RD HD MACH 4-40 X 1	3
26	011248-049	NUT HEX 4-40 ESNA	3

## OUTRIGGER ASSEMBLY

LX50 DUAL DECK

067950-001

ITEM	PART	DESCRIPTION	QTY.
1	067844-000	OUTRIGGER SUPPORT WELDMENT	4
2	067840-000	OUTRIGGER CYL.	4
3	067957-001	CONTROL MODULE ASSY	1
4	064794-000	LEVEL MOUNT	1
5	067954-000	CONTROLLER ASSY	1
6	011240-008	WASHER 1/2 STD FLAT	32
7	011246-008	NUT HEX ESNA 1/2-13 UNC	16
8	011256-020	SCREW HHC 1/2-13UNC X 2 1/2	16
9	062881-000	SWITCH BALL	4
10	063921-006	SWITCH PRESS.	4
11	066516-004	PLUG	4
12	064462-002	GROMMET, CAPLUG #GRO-1/2-UL	4
13	011941-005	FITTING 6MB-6MJ	4
14	011934-004	FITTING 6MBH-6MJ 90	4
15	011937-003	FITTING 6FJX-6MJ 90	4
16	066556-001	LABEL CAUTION	4
17	067642-001	LABEL CONTROLLER	1
18	066551-003	LABEL TIPPING	1
20	067953-000	HOSE KIT / INST. (NOT SHOWN)	1
21	014924-008	U-BOLT	2
22	011248-004	NUT HEX 1/4-20 ESNA	4
23	005133-000	SPRING	3
24	000942-000	ORBIT LEVEL	1
25	011721-008	SCREW RD HD MACH 4-40 X 1	3
26	011248-049	NUT HEX 4-40 ESNA	3

# Illustrated Parts Breakdown

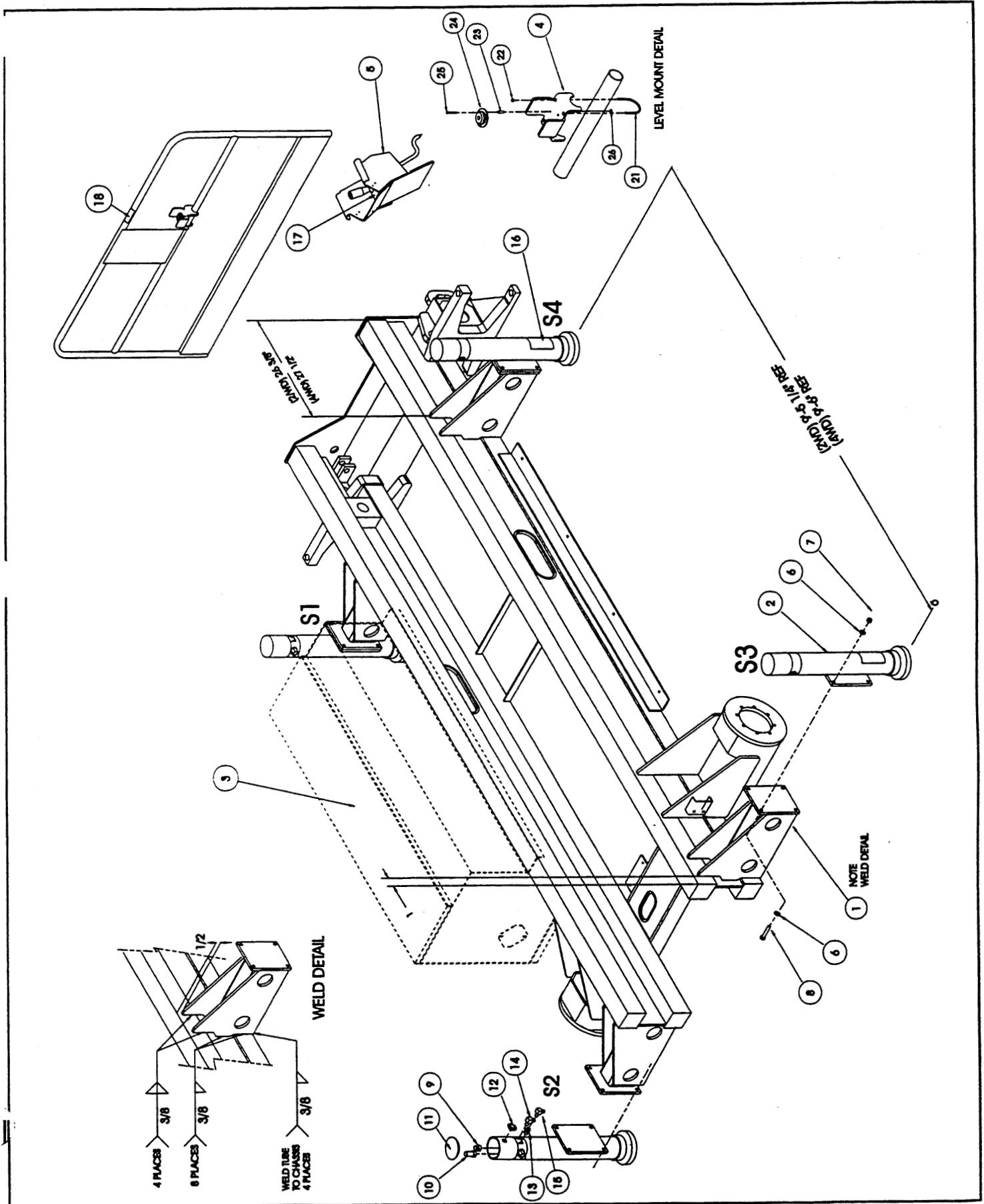

**CONTROL BOX ASSEMBLY/OUTRIGGER  
LX50  
067957-000**

ITEM	PART	DESCRIPTION	QTY.
1	067661-001	RELAY SPDT	10
2	067662-001	SOCKET RELAY	10
3	067662-005	RETAINER CLIP	20
5	029620-002	CONN BUTT 16-14	20
6	029610-003	CONN FORK #8 16-14	66
7	005469-099	WIR 16 AWG 9 COND	FT4
8	029931-003	CONN FM PUSH 16-14 1/4	16
9	029601-014	CONN RING 1/4 16-14	3
10	020733-005	FITTING TEE 12FLX-12MJ-12MJ	1
11	014693-003	FITTING ADA 12FJ-6MJ	1
12	011934-024	FITTING ADA 10MBH-6MJ 90° EL	1
13	067956-000	VALVE BLOCK ASSY	1
14	011252-032	SCREW HHC 1/4-20UNC X 4	2
15	011248-004	NUT HEX ESNA 1/4-20UNC	2
16	011941-013	FITTING 10MB-6MJ STR	1
17	029601-014	TERMINAL, RING Ø 1/4	1
18	029496-099	WIRE 2 CONND. 16 GA	FT 70

# Illustrated Parts Breakdown

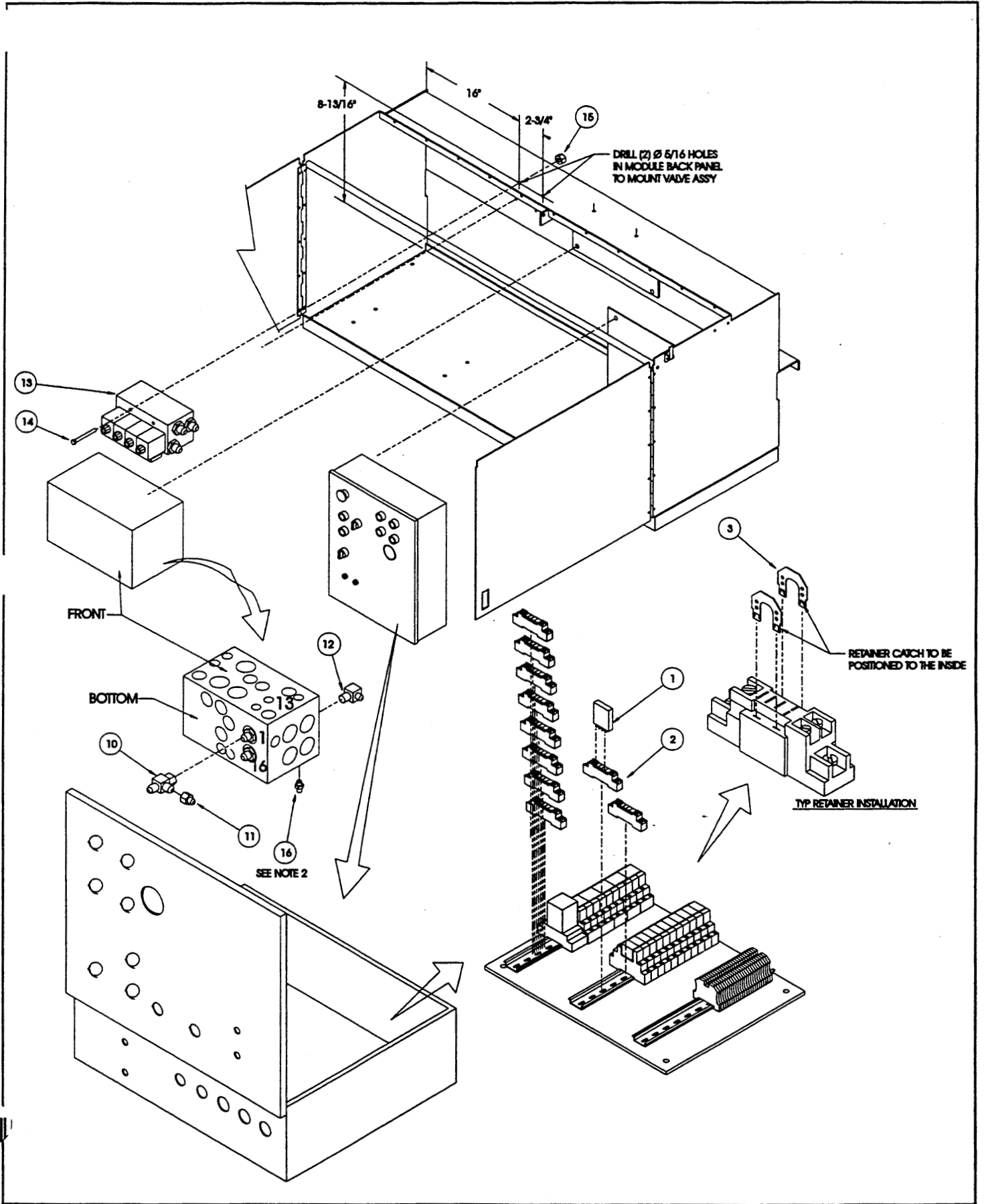



# Illustrated Parts Breakdown

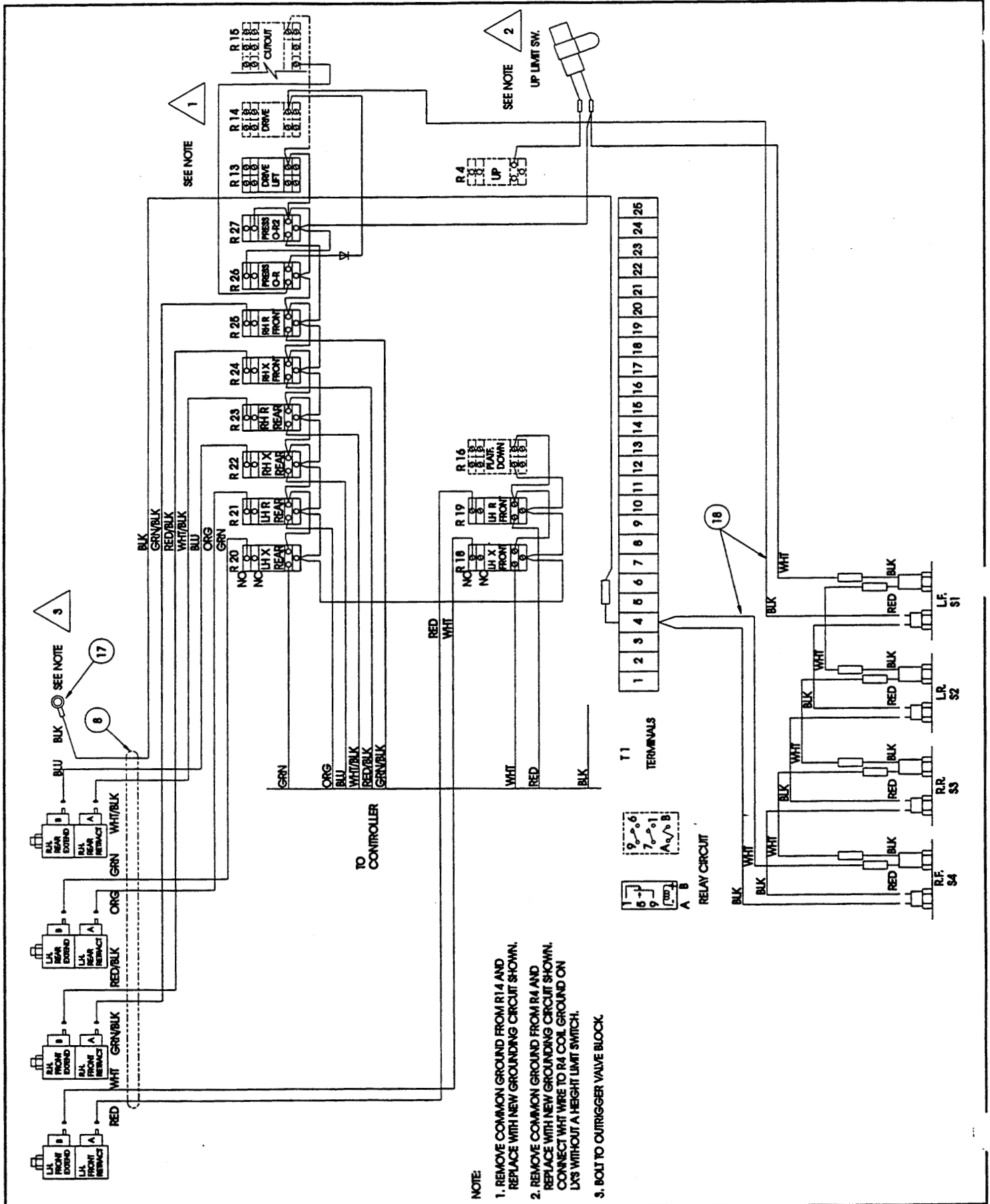

NOTE:

1. REMOVE COMMON GROUND FROM R14 AND REPLACE WITH NEW GROUNDING CIRCUIT SHOWN.
2. REMOVE COMMON GROUND FROM R4 AND REPLACE WITH NEW GROUNDING CIRCUIT SHOWN. CONNECT WHT WIRE TO R4 COIL GROUND ON LX3 WITHOUT A HEIGHT LIMIT SWITCH.
3. BOLT TO OUTRIGGER VALVE BLOCK.

NOTES:

**CONTROL BOX ASSEMBLY/OUTRIGGER  
LX50 DUAL DECK  
067957-001**

ITEM	PART	DESCRIPTION	QTY.
1	067661-001	RELAY SPDT	10
2	067662-001	SOCKET RELAY	10
3	067662-005	RETAINER CLIP	20
5	029620-002	CONN BUTT 16-14	20
6	029610-003	CONN FORK #8 16-14	66
7	005469-099	WIR 16 AWG 9 COND	FT4
8	029931-003	CONN FM PUSH 16-14 1/4	16
9	029601-014	CONN RING 1/4 16-14	3
10	020733-005	FITTING TEE 12FLX-12MJ-12MJ	1
11	014693-003	FITTING ADA 12FJ-6MJ	1
12	011934-024	FITTING ADA 10MBH-6MJ 90° EL	1
13	067956-000	VALVE BLOCK ASSY	1
14	011252-032	SCREW HHC 1/4-20UNC X 4	2
15	011248-004	NUT HEX ESNA 1/4-20UNC	2
16	011941-013	FITTING 10MB-6MJ STR	1
17	029601-014	TERMINAL, RING Ø 1/4	1
18	029496-099	WIRE 2 CONND. 16 GA	FT 70
19	063497-001	MERCURY SWITCH	1
20	013919-013	CLAMP	1
21	014066-008	1/4-AB X 1 SELF TAPPING SCREW	1

# Illustrated Parts Breakdown

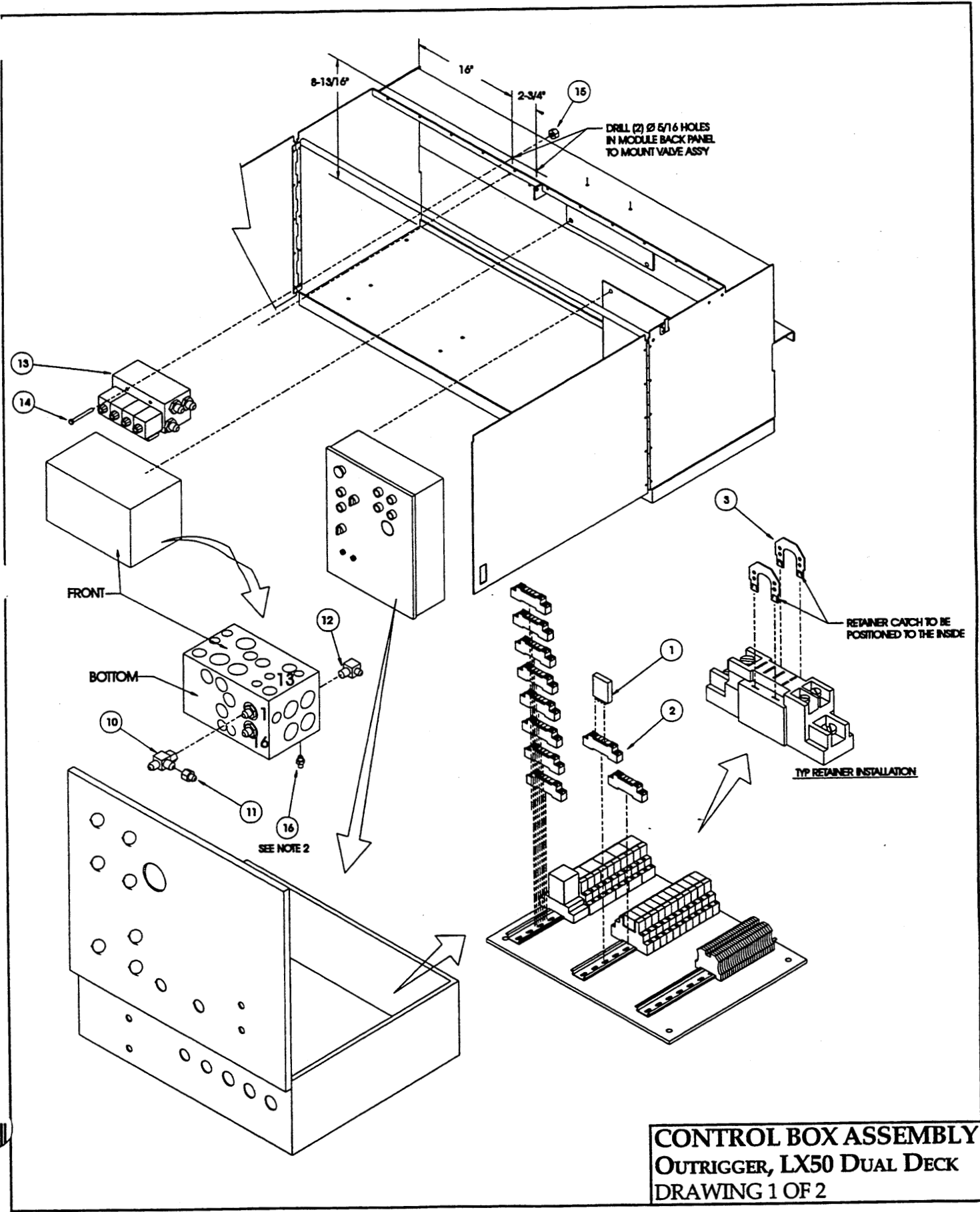

# Illustrated Parts Breakdown

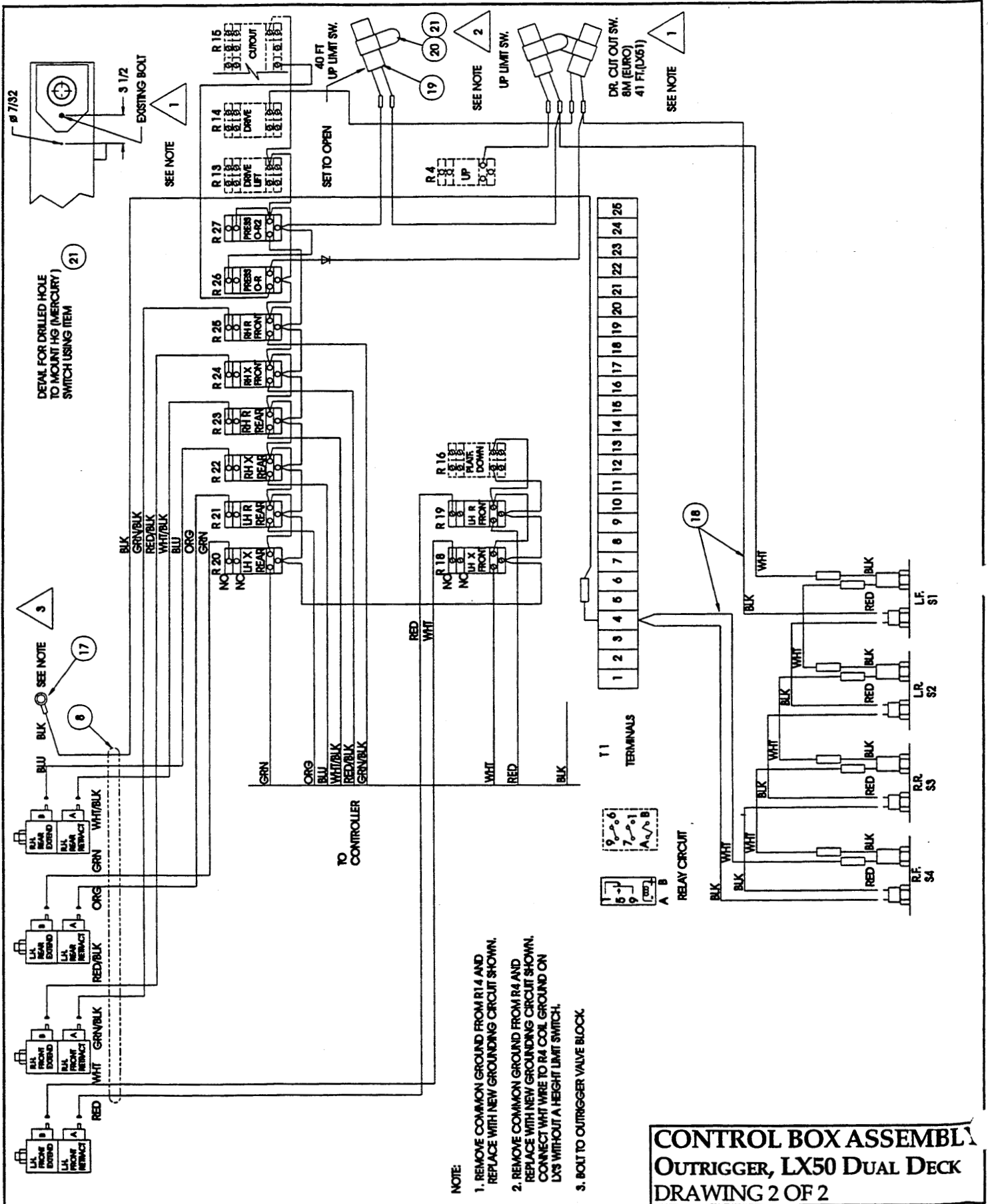

# Illustrated Parts Breakdown

## VALVE BLOCK ASSEMBLY/OUTRIGGER

\_X50

067956-000

ITEM	PART	DESCRIPTION	QTY.
1	067525-000	VALVE BLOCK OUTRIGGER	1
2	011934-001	FITTING 90° EL 4MBH-4MJ	1
3	011941-001	FITTING STR 4MB-4MJ	1
4	011941-005	FITTING STR 6MB-6MJ	10
5	063664-008	FITTING ORIFICE .070	1
6	011937-003	FITTING 90° EL 6FJX-6MJ	2
7	067956-003	VALVE W/ COIL #8 4-WAY	4

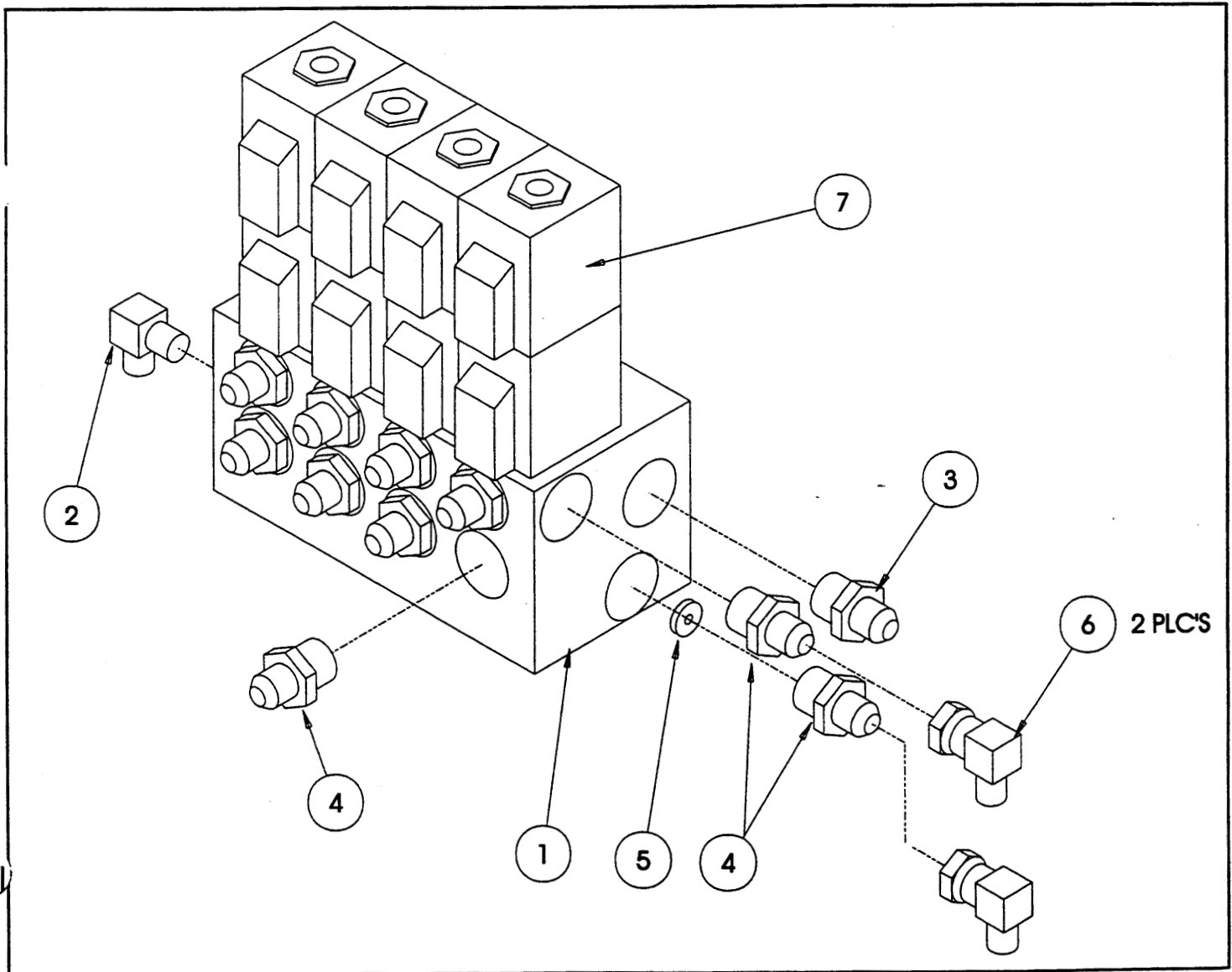

# Illustrated Parts Breakdown

## CONTROLLER ASSEMBLY/OUTRIGGER

LX50

067954-000

ITEM	PART	DESCRIPTION	QTY.
1	012798-000	TOGGLE SWITCH SPDT-MOMENTARY	4
2	068133-000	LIGHT, GREEN INDICATOR	1
3	029610-004	CONN. FORK #10 12-10GA.	16
4	005469-099	WIRE 16AWG X 9 COND.	FT95
5	029452-099	WIRE 16AWG BLK	FT1

ITEM	PART	DESCRIPTION	QTY.
6	029925-000	CONN. CABLE	1
7	029939-002	NUT LOCK 1/2NPT	1
8	067806-000	RING, SELF LOCKING 1/2	1
9	029872-000	SWITCH BOOT	4

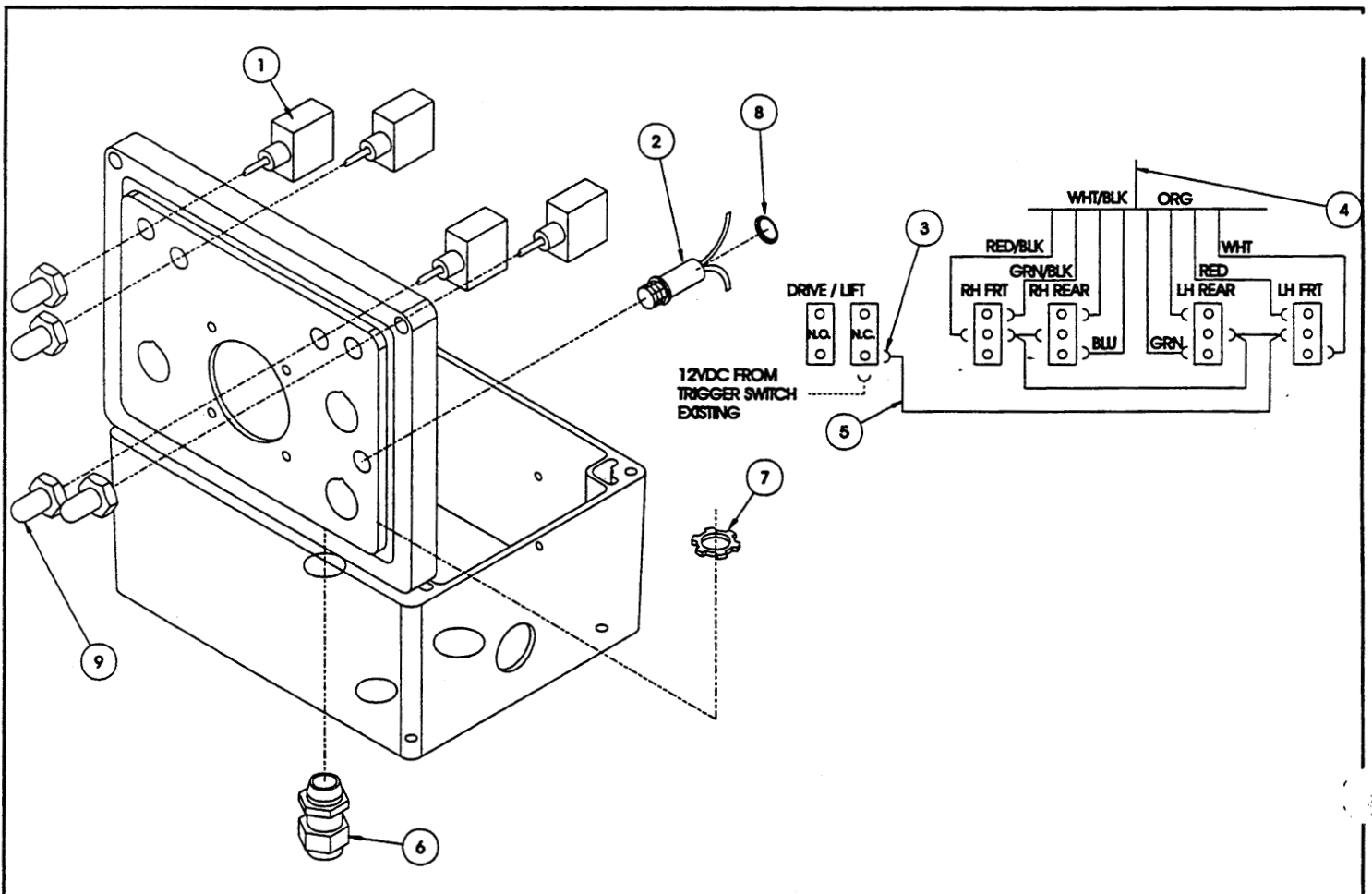

# Illustrated Parts Breakdown

## MOTION ALARM OPTION

LX50

067909-000

ITEM	PART	DESCRIPTION	QTY.
1	029452-099	WIRE 16 GA BLK	FT2
2	029610-002	TERMINAL #8 FORK	4
3	029825-002	DIODE 3 AMP	3

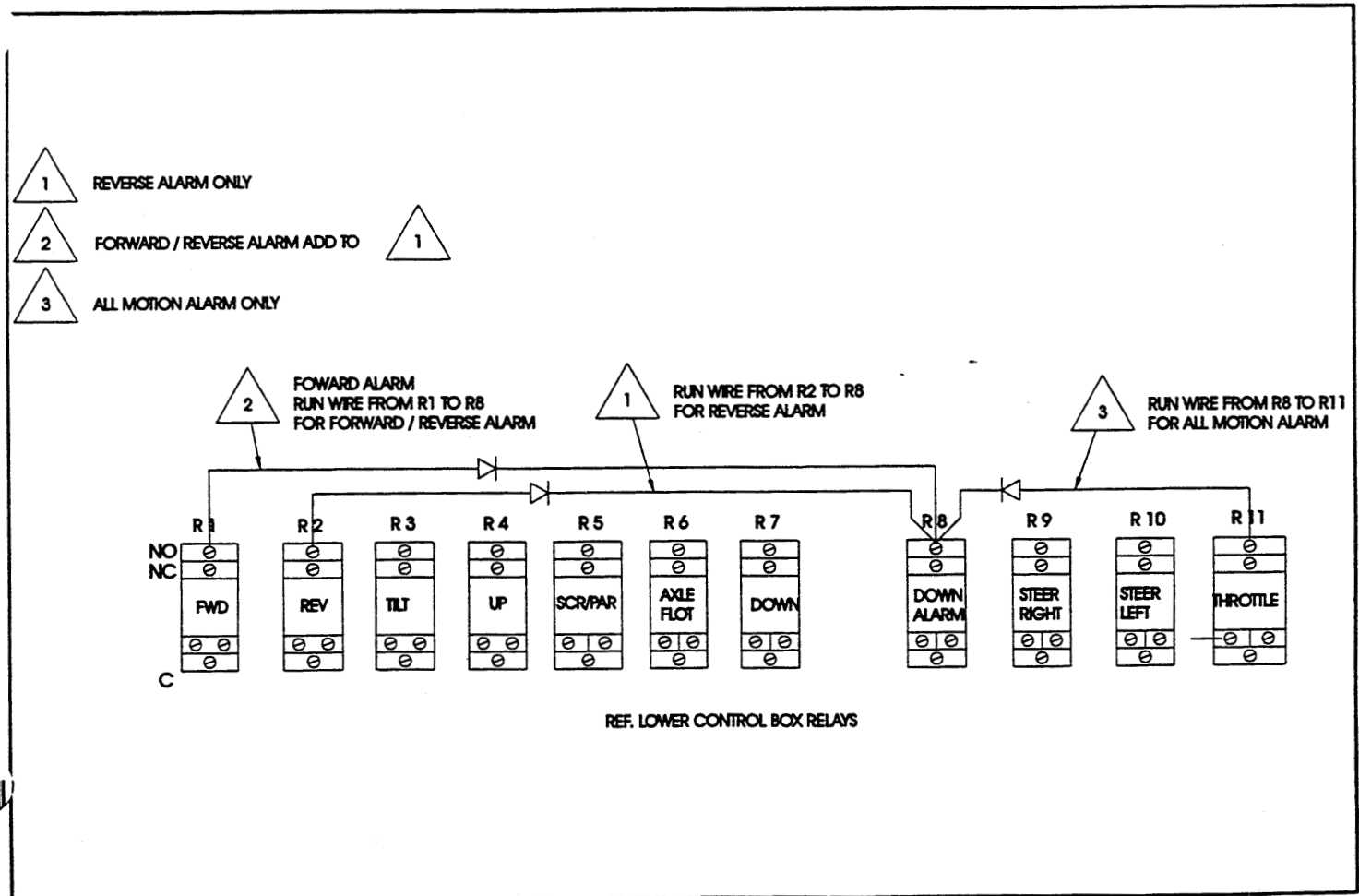



NOTES:

---

**UpRight, Inc.**

801 South Pine Street  
Madera, California 93637

TEL: 559-662-3900

FAX: 559-673-6184

PARTS: 1-888-UR-PARTS

PARTS FAX: 1-800-669-9884

**UpRight**

Call Toll Free in U.S.A.

1-800-926-LIFT

P/N 067904-003

12-02

**UpRight**

Unit S1, Park West Industrial Park

Friel Avenue

Nangor Road

Dublin 12, Ireland

TEL: +353 1 620 9300

FAX: +353 1 620 9301