

# UpRight

---



# SB60

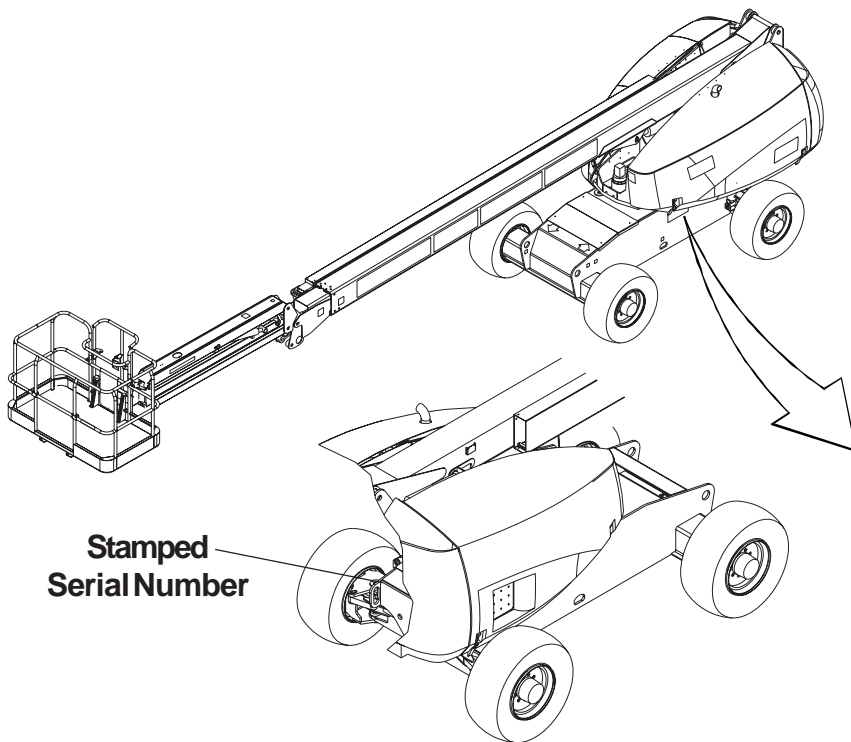
***WORK PLATFORMS***

**Service &  
Parts Manual**

# SERVICE & PARTS MANUAL

## SB60

Gas & Diesel Models  
Serial Numbers 1000 to current



When contacting UpRight for service or parts information, be sure to include the MODEL and SERIAL NUMBERS from the equipment nameplate. Should the nameplate be missing the SERIAL NUMBER is also stamped on top of the chassis in the rear.

<b>UpRight Inc.</b>	
1775 PARK ST. SELMA CALIFORNIA 93662 USA	
Model: _____	Serial number: _____
GVW: _____ lbs. _____ kg.	Mfg. date: _____
Maximum allowable incline of machine when elevated: _____ deg.	
Occupants and equipment must not exceed the rated maximum load: _____ lbs. _____ kg	
Maximum platform occupants: _____	
Maximum allowable side force on platform: _____ lbs. _____ N	
Maximum platform height: _____ ft. _____ m	
Maximum platform reach: _____ ft. _____ m	
Maximum allowable wind speed: _____ mph _____ km/h	
Maximum hydraulic system pressure: _____ psi _____ bar	
Maximum system voltage: _____ vdc	
This machine is manufactured to comply with ANSI A92.5-1992.	
CAUTION: CONSULT OPERATOR'S MANUAL BEFORE USE.	
THIS PLATFORM IS NOT ELECTRICALLY INSULATED	

# UpRight

Call Toll Free in U.S.A.  
**1-800-926-LIFT**

**UpRight, Inc.**  
1775 Park Street  
Selma, California 93662  
TEL: 559/891-5200  
FAX: 559/896-9012  
PARTS: 1-888-UR-PARTS  
PARTSFAX: 559/896-9244

**100029-000**

9902 .2K Rev-A

# Foreword

## Introduction

### HOW TO USE THIS MANUAL

This manual is divided into 6 sections. The right hand pages of each section is marked with a black tab that lines up with one of the thumb index tabs on the right side of this page. You can quickly find each section without looking through the table of contents which follows this page. The section number printed at the top corner of each page can also be used as a quick reference guide.

### SPECIAL INFORMATION



#### DANGER



Indicates the hazard or unsafe practice **will** result in severe injury or death.



#### WARNING



Indicates the hazard or unsafe practice **could** result in severe injury or death.



#### CAUTION



Indicates the hazard or unsafe practice could result in **minor** injury or property damage.

NOTES: Give helpful information.

### WORKSHOP PROCEDURES

**CAUTION:** Detailed descriptions of standard workshop procedures, safety principles and service operations are not included. Please note that this manual does contain warnings and cautions against some specific service methods which could cause personal injury, or could damage a machine or make it unsafe. Please understand that these warnings cannot cover all conceivable ways in which service, whether or not recommended by UpRight, Inc., might be done, or of the possible hazardous consequences of each conceivable way, nor could UpRight Inc. investigate all such ways. Anyone using service procedures or tools, whether or not recommended by UpRight Inc., must satisfy themselves thoroughly that neither personal safety nor machine safety will be jeopardized.

All information contained in this manual is based on the latest product information available at the time of printing. We reserve the right to make changes at any time without notice. No part of this publication may be reproduced, stored in retrieval system, or transmitted, in any form by any means, electronic, mechanical, photocopying, recording, or otherwise, without the prior written permission of the publisher. This includes text, figures and tables.

## Introduction & Specifications

1.0

General description and machine specifications.

## Operation

2.0

Operating instructions and safety rules.

## Maintenance

3.0

Preventative maintenance and service information.

## Troubleshooting

4.0

Causes and solutions to typical problems.

## Schematics

5.0

Schematics and valve block diagram with description and location of components.

## Illustrated Parts Breakdown

6.0

Complete parts lists with illustrations.

0

1.3

2.7

4.1

5.5

6.8

8.25

# Forword

## *NOTES*

## 1.0 Introduction

### PURPOSE

The purpose of this service and parts manual is to provide instructions and illustrations for the operation and maintenance of the SB60 Work Platform manufactured by UpRight, Inc. of Selma, California.

### SCOPE

The manual includes procedures for proper operation, maintenance, adjustment, and repair of this product as well as recommended maintenance schedules and troubleshooting.

## 1.1 General Description

The SB60 Work Platform consists of the platform, controller, elevating assembly, power module, control module, and chassis.

### Platform

The platform has a reinforced steel floor, 43.5 inch (1.11 m) high guardrails with midrail, 6 inch (152 mm) toeboards and an entrance gate at the side of the platform.

**⚠ WARNING ⚠**

**DO NOT** use the maintenance platform without guardrails properly assembled and in place.

### Platform Controller

The platform controller contains the controls to operate the machine. It is located at the front of the platform cage. The foot switch must be depressed to operate any function from the platform. A complete explanation of control functions can be found in *Section 2*.

### Elevating Assembly

The hydraulic pump, driven by the engine, powers the cylinders. Solenoid operated valves control raising and lowering.

### Chassis

The chassis is a structural frame that supports all the components of the SB60 Work Platform. The Platform is raised and lowered using an extendable boom with jib. Boom functions, Jib functions, Cage Rotate and Leveling are achieved using single stage cylinders.

### Turret

The Turret is mounted on the Chassis. It supports the Elevating Assembly, Power Module and Control Module. The Turret is capable of rotating 360° on the Chassis.

## PURPOSE OF EQUIPMENT

The objective of the SB60 Work Platform is to provide a quickly deployable, self propelled, variable height work platform to elevate personnel and materials to overhead work areas.

## SPECIAL LIMITATIONS

Travel with the platform raised is limited to a creep speed range.

Elevating of the Work Platform is limited to firm, level surfaces **only**. Any degree of slope greater than 5° will sound a warning alarm when machine is elevated. If machine is lowered, a light will illuminate on platform control box.

**⚠ DANGER ⚠**

The elevating function shall **ONLY** be used when the work platform is level and on a firm surface. The work platform is **NOT** intended to be driven over uneven, rough or soft terrain when elevated.

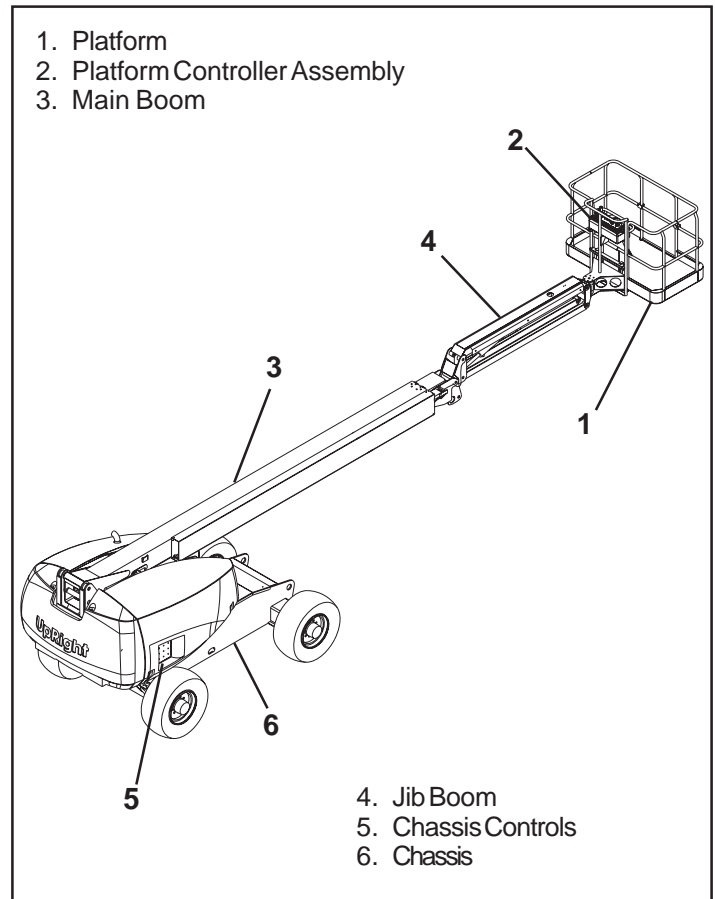
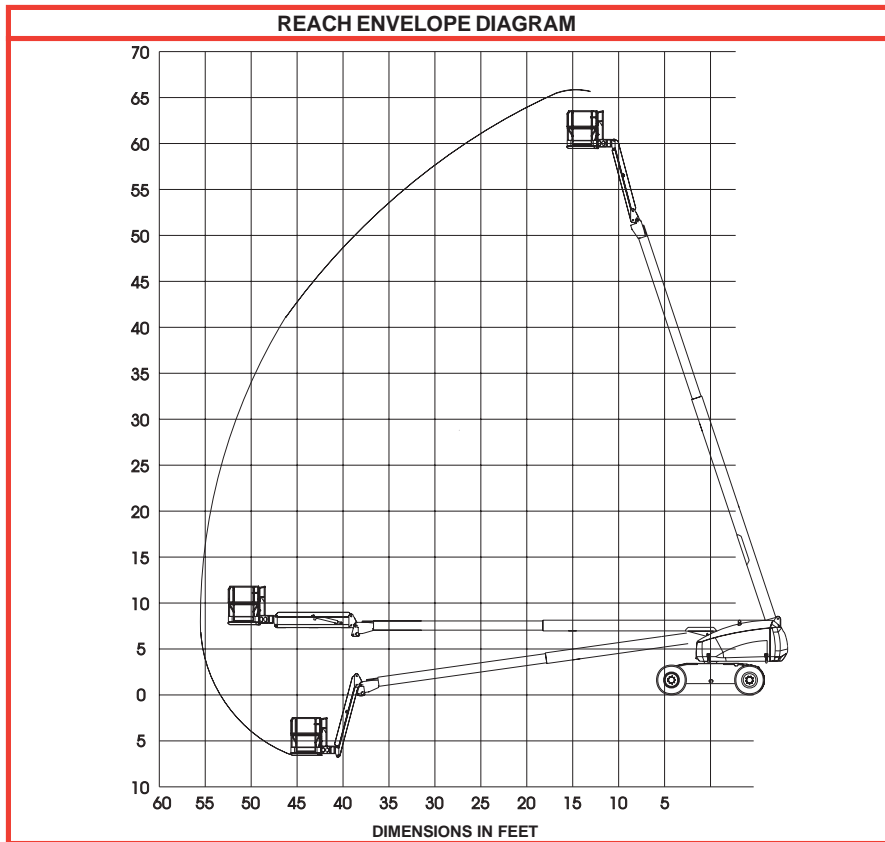


Figure 1-1: SB60 Work Platform

## 1.2 Specifications



ITEM	SPECIFICATION	ITEM	SPECIFICATION
Height		Dimensions (boom stowed)	
Working height maximum	66 ft.	Platform Size	39 in. x 72 in. opt. 39 in. x 96 in.
Platform height maximum	60 ft.	Guardrail height	43 1/2 in.
Platform step in height	6 in.	Toeboards	6 in.
Up and over height	7 ft. 6 in.	Maximum platform capacity	500 lbs.
Drivable height	60 ft.	Maximum no. of occupants	2
Horizontal outreach	52 ft. 8 in.	Weight \ Gasoline	23,700 lbs.
Turret rotation	360 deg. continuous	Weight \ Diesel	24,100 lbs.
Platform rotation	180 deg.	Overall height (Stowed)	8 ft. 6 in.
Tail swing	53 in.	Overall length (Stowed)	29 ft. 8 3/4 in.
Jib length	8 ft.	Overall width	7 ft. 11 3/4 in.
Jib arc	150 deg.	Wheelbase	8 ft. 6 in.
Insideturning radius	12 ft. 6 in.	Wheeltrack	59 in.
Outsideturning radius	22 ft. 2 in.	Ground Clearance	11 1/2 in.
Drivespeed (lowered)	4 mph	Powersource \ Gasoline	GM 3.0 Liter
Drivespeed (elevated)	.7 mph	Powersource \ Diesel	Perkins 704-30
Gradability	4%	System voltage	12VDC
Controls	Electric Proportional	Maximum Hyd. Pressure	5000 psi
Tires	14 ply lug tread (80 psi)		

Table 1-1: Specifications

\* Specifications subject to change without notice.

Meets or exceeds all applicable requirements of OSHA and ANSI A92.5-1992

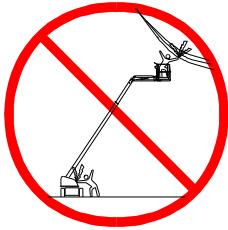
# OPERATION

## WARNING

All personnel shall carefully read, understand and follow all safety rules, operating instructions, and the Scaffold Industry Association's MANUAL OF RESPONSIBILITIES (ANSI A92.5) before operating or performing maintenance on any UpRight boom supported aerial work platform.

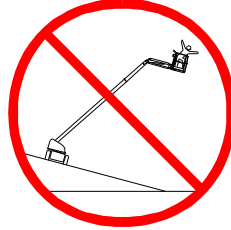
## SAFETY RULES

### Electrocution Hazard



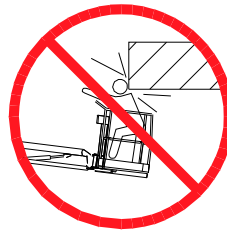
**NEVER** operate the machine within ten (10) feet of power lines. **THIS MACHINE IS NOT INSULATED.**

### Tip Over Hazard



**NEVER** operate the boom or drive with platform elevated unless on firm level surface.

### Collision Hazard



**NEVER** position the platform without first checking for overhead obstructions or other hazards.

### Fall Hazard



**NEVER** climb, stand or sit on platform guard-rails or midrail.

**ALL** occupants must wear an approved fall restraint properly attached to designated platform anchorage point. Attach only one fall restraint to each anchorage point.

**NEVER** exceed maximum platform load of 500 lbs. (225 kg) and two (2) occupants.

**NEVER** exceed 45 lbs. (200 N) of side force per occupant.

**DISTRIBUTE** all platform loads evenly on the platform.

**NEVER** operate the machine without first surveying the work area for surface hazards such as holes, drop-offs, bumps, curbs, or debris; and avoiding them.

**OPERATE** machine only on surfaces capable of supporting wheel loads.

**NEVER** elevate the machine when wind speeds exceed 28 mph (12.5 m/sec.).

**IN CASE OF EMERGENCY** push emergency stop button to deactivate all powered functions.

**ALWAYS** close and secure sliding rail after entering platform.

**NEVER** exit or enter platform while elevated.

**NEVER** use ladders, scaffolding, or other items to gain height; work only from the platform floor.

**NEVER** climb down elevating assembly while platform is elevated.

**INSPECT** the machine thoroughly for cracked welds, loose or missing hardware, hydraulic leaks, loose wire connections, and damaged cables or hoses before using.

**VERIFY** that all labels are in place and legible before using.

**NEVER** use a machine that is damaged, not functioning properly, or has damaged or missing labels.

**IF ALARM SOUNDS** while boom is elevated, **STOP**, carefully retract boom and lower platform without rotating. Move machine to a firm, level surface.

**NEVER** attach overhanging loads or use boom as a crane.

**NEVER** alter operating or safety systems without manufacturers written consent.

**NEVER** charge batteries near sparks or open flame. Charging batteries emit explosive hydrogen gas.

**NEVER** replace any component or part with anything other than original UpRight replacement parts without the manufacturer's written consent.

**NEVER** tow the machine. Transport by truck or trailer only.

**AFTERUSE**, secure the work platform from unauthorized use by turning both keyswitches off and removing key.

### California Proposition 65 Warning

Gasoline and diesel engine exhaust and some of their constituents are known to the State of California to cause cancer, birth defects, and other reproductive harm.

## Introduction

This manual covers the operation of internal combustion powered models of the SB60 Boom.

## Pre-Operation and Safety Inspection

Carefully read, understand and follow all safety rules, labels, and operating instructions, then perform the following steps each day before use.

Perform a complete visual inspection of the entire unit prior to operating. Check the following areas for discrepancies:

1. Open panels and check hydraulic components / hoses for damage or leaks. Check electrical components / wiring for damage or loose connections.
2. Inspect chassis, axles, hubs, and steering linkage for damage, deformation, buckled paint, loose or missing hardware, and cracked welds.
3. Check tires for damage, punctures, and inflation; tire pressure must be 80 psi (5.5 bar)
4. Check all hoses / cables for wear.
5. Inspect elevating assembly for damage, deformation, buckled paint, loose or missing hardware, and cracked welds.
6. Inspect platform and guardrails for damage, deformation, buckled paint, loose or missing hardware, and cracked welds. Insure that gate operates freely and latches securely.
7. Check Hydraulic fluid level with platform fully lowered.
8. Check fluid level in batteries (see battery maintenance, page 2-8).
9. Check fuel level, add fuel if necessary (see *fueling*, page 2-8).
10. Check engine oil level.
11. Check air filter. Replace if necessary.
12. Set gasoline/propane selector to desired position. Set to center position to purge the system when switching fuels. If the machine is to be operated on propane, open the supply valve on the tank.

**NOTE:** When using LP gas, use clean, water free liquid petroleum gas, preferably from a bulk storage tank.

### ⚠ WARNING ⚠

NEVER remove the cap from a hot radiator. Hot coolant can cause severe burns.

13. Ensure that radiator is cold, check coolant level. Add if necessary.



### WARNING



If you smell propane, close the supply valve on the tank immediately until you have located and corrected the leak.

## SYSTEM FUNCTION INSPECTION

**Note:** Refer to figures 2-2 through 2-5 for chassis and platform control locations.

1. Before performing the following tests, check area around machine and overhead for obstructions, holes, drop-offs, and debris.
2. Turn chassis key switch to chassis, and pull out emergency stop switches at the chassis control panel and at the platform control panel.
3. Retract locking bolt. See figure 2-1.
4. Press the engine start button to crank the engine; release when engine starts. If engine is cold: press the glow plug button and hold for six seconds prior to starting diesel models.
5. Push in the chassis emergency stop button, engine should stop. Repeat for platform emergency stop button. Return both emergency stop buttons to the on position, and start engine.
6. Operate each function switch to raise / lower, extend / retract, rotate left / right, each section of the elevating assembly and observe the operation of the machine. All functions should operate through full cycle smoothly.
7. Turn chassis key switch to platform.
8. Mount the platform, and attach approved fall restraint to designated platform anchorage point. Attach only one fall restraint to each point.
9. While engaging the hand interlock, move the drive control handle forward and reverse. Observe that proportional functions operate smoothly, and that brakes apply quickly after control is released.
10. While engaging the hand interlock, operate steer switch to left and right. Observe that steering wheels turn properly.



Figure 2-1: Locking bolt



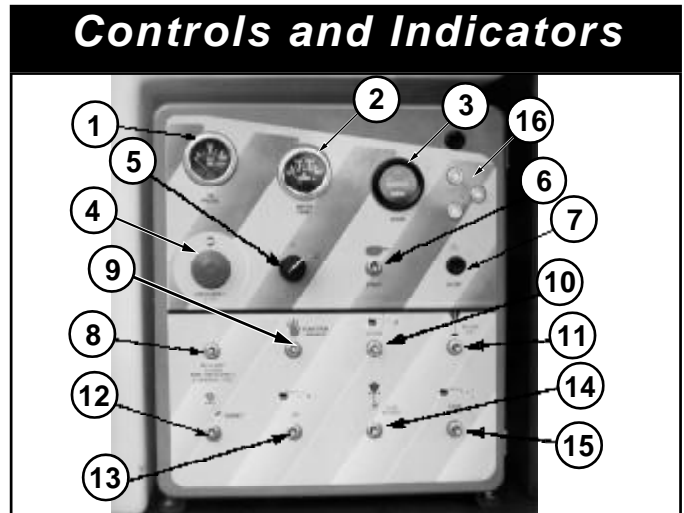
11. While depressing foot switch, operate boom controls. Observe that boom operates smoothly, and that boom raise and lower, turret rotation, and boom extension and retraction operate proportionally in conjunction with stroke of handle. Observe that platform maintains level when boom is elevated.
12. With the boom elevated five degrees above horizon or greater, operate drive control handle. Observe that drive speed is limited to creep (1 foot [.30m] per second). Lower upper boom to stowed position.
13. Press the service horn button. Observe that horn is audible.

**NOTE: Hand interlock controls drive/steer functions only.**

**NOTE: Foot switch controls boom functions only.**

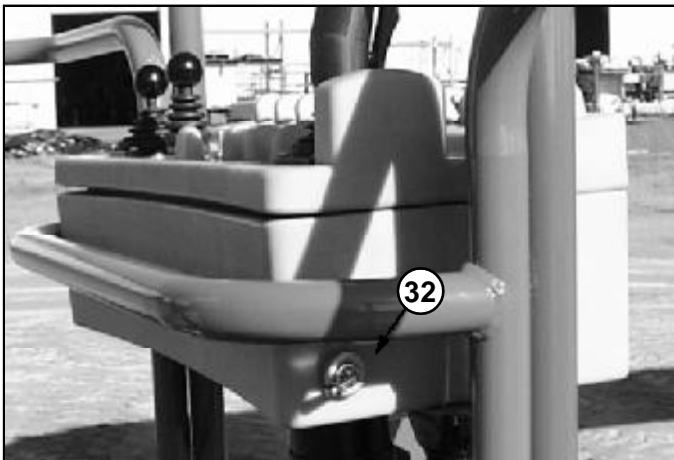
**⚠ WARNING ⚠**

DO NOT use a machine that is damaged or malfunctioning. Tag and remove the unit from service until it is repaired.

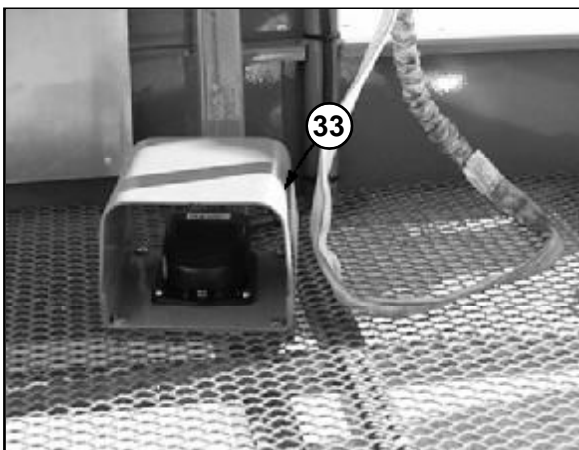


**Figure 2-4: Chassis Controls**

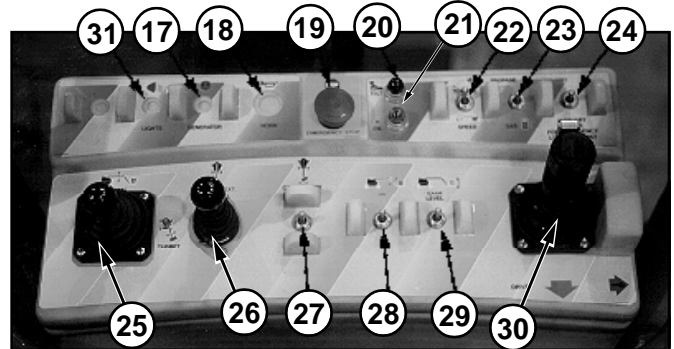
1. Oil pressure gauge
2. Water temperature gauge
3. Hourmeter
4. Emergency stop
5. Key switch
6. Engine start
7. Glow plug (Diesel only)
8. Auxiliary power for emergency lowering only
9. Function enable
10. Boom control
11. Boom extension control
12. Turret control
13. Jib control
14. Cage rotation
15. Cage level control
16. Circuit breaker



**Figure 2-2: Platform Controls**



**Figure 2-3: Platform Controls**



**Figure 2-5: Platform Controls**

17. Generator (optional)
18. Horn button
19. Emergency stop
20. Tilt warning indicator
21. Low oil pressure indicator
22. Torque/Speed selector
23. Fuel selector (Gasoline only)/Glow plug (Diesel only)
24. Auxiliary power for emergency lowering only
25. Boom/Turret control
26. Boom extension control
27. Cage rotate control
28. Jib control
29. Cage level control
30. Drive control handle/interlock
31. Lights (optional)
32. Engine start switch
33. Foot interlock switch

## Operation

Before operating work platform insure that:

Pre-operation and safety inspection has been completed, and any discrepancies have been corrected.

System function inspection has been performed.

Operator has been thoroughly trained on the operation of the machine.

Work area is clear of all obstructions, holes, drop-offs, or persons in the route of travel.

Surface is capable of supporting wheel loads.

Refer to figures 2-2 through 2-5 for control locations.



### Emergency Stop

At any time during operation, press the emergency stop button to stop all functions in an emergency.



### Service Horn

At any time during operation, press the service horn button to sound an audible warning if necessary.



### WARNING

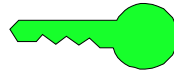


**Always** wear an approved fall restraint properly attached to designated platform anchorage point when driving or operating the machine (see figure 2-6).

Attach only one fall restraint to each anchorage point.



Figure 2-6: Typical Fall Restraint Anchorage Point



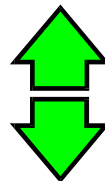
## Starting the engine

### From the lower controls

1. Turn the chassis key switch to chassis position.
2. Press the start button to crank the engine. Release when the engine starts.
3. Diesel Engines: When the engine is cold, press and hold the glow plug button for six seconds prior to starting.

### From the platform controls

1. Turn the chassis key switch to platform controls.
2. Turn the platform rotary switch fully clockwise to crank the engine. Release when engine starts.
3. Diesel Engines: When the engine is cold, press and hold the glow plug button for six seconds prior to starting.



## Driving

### With Boom Lowered

1. Turn chassis key switch to platform, and pull out the chassis emergency stop switch.
2. Mount the platform and close sliding rail.
3. Attach approved fall restraint to designated platform anchorage point. Attach only one fall restraint to each point.
4. Start engine.
5. Check that the area around and above the work platform is clear of obstructions, holes, drop-offs, persons in the route of travel, and the surface is capable of supporting wheel loads.
6. Engage the interlock switch and move the drive control handle forward to travel forward and rearward to travel in the reverse direction.

**Note:** When the boom is rotated to the front of the chassis (steering wheels aft) directions of travel and steering will be reversed. Observe the color coded arrows on the control panel near the drive control handle, and on the chassis. They will indicate the direction of travel when the drive control handle is moved.

## With Boom Elevated

Travel with boom elevated is restricted to firm level surfaces only.

When driving elevated, the machine will travel at creep speed (1 foot [.30 m] per second).

### Steering

1. While engaging the hand interlock, push the steering switch (located on top of the control handle) to the left to turn left, and right to turn right.

**Note: Steering is not self centering. Wheels must be returned to the straight ahead position by operating the steering switch.**

## POSITIONING THE PLATFORM

Positioning the platform as close as possible to the work area requires some planning. First, you must survey the work site to find a suitable place to park the machine. This must be a firm level area as close as possible to the work area. Take into consideration all obstructions on the ground and overhead and avoid them.

Always, before operating any function, check the area around and overhead for any obstructions or electrical conductors.



### WARNING



**NEVER** exit the platform while the boom is elevated. Keep both feet firmly on platform floor at all times. Do not use planks, ladders, or any other device on the platform for achieving additional height or reach.

## Multifunction Controls

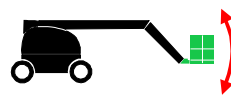
The UpRight SB60 employs the use of multifunction controls. This means that any two functions can operate at full speed simultaneously.

The turret may be rotated while driving if necessary to make turns in tight areas. All other boom functions will not operate while driving.

## Lower Control Operation

All boom functions will operate at fixed speed.

1. Turn chassis keyswitch to chassis controls.
2. With engine running, operate boom control switches to position the platform.



## Leveling the Platform



### WARNING



DO NOT operate the machine if the platform does not maintain level when elevated.

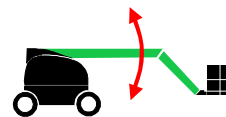
**Note: Platform leveling can be performed only with the boom stowed and should be done only to calibrate the automatic leveling system.**

While depressing the foot switch, move the platform level control switch forward to swing the platform upward, rearward to swing the platform downward. Release the switch to stop leveling. Leveling can be performed only when boom is stowed and retracted.



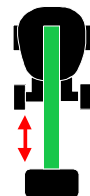
## Rotating the Turret

While depressing the foot switch, move the boom rotation joystick to the right to rotate right, left to rotate left. Release the switch to stop rotation. The turret rotation will function at a speed proportional to the stroke of the joystick. Make sure the area around the boom is clear of all obstructions before rotating the turret.



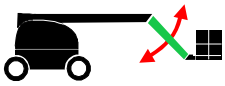
## Elevating the Boom

While depressing the foot switch, move the joystick forward to elevate the boom, rearward to lower the boom. Release the control lever to stop elevating / lowering. The boom elevate will function at a speed proportional to the stroke of the joystick.



## Extending the Boom

While depressing the foot switch, move the boom extension control joystick rearward to extend the boom, forward to retract the boom. Release the control lever to stop extending / retracting. The boom extension will function at a speed, proportional to the stroke of the joystick.



## Elevating the Jib

While depressing the foot switch, push the jib control switch forward to elevate the jib, rearward to lower the jib. Release the control lever to stop elevating / lowering.



## Rotating the Platform

While depressing the foot switch, toggle the control switch left to rotate left, right to rotate right. Release the switch to stop rotation.

## EMERGENCY OPERATION

In the event of an engine failure, the elevating assembly may be lowered using the following procedure.



### WARNING



**NEVER** climb down the elevating assembly. If controls do not respond, follow the emergency lowering procedure.

## Lowering Elevating Assembly

1. Engage the auxiliary power unit switch.
2. Operate any boom function in the normal manner.

Note: Auxiliary battery is capable of one emergency lowering cycle before requiring recharge. Battery is recharged while engine is in operation.

## EMERGENCY TOWING



### CAUTION



DO NOT tow the machine faster than 3 mph. Faster speeds will damage drive components and void warranty.



### WARNING



There are no brakes when the center caps are installed in the inverted position.

Perform the following only when the machine will not operate under its own power and it is necessary to move the machine or when winching onto a trailer for transportation.

1. Insure that the platform is fully lowered, and that the turret is rotated so that the platform is to the rear of the machine.
2. Refer to figure 2-7 and disengage all four drive hubs. Remove two (2) screws and center cap. Reinstall center cap in the opposite direction.



### WARNING



Chock wheels before disengaging hubs. Machine may roll.

3. When ready to move the machine, remove the chocks. Tow or winch into position and replace chocks.
4. Attach adequate chain/cable of sufficient strength for towing the machine to the front or rear tie down lugs.
5. Engage all four drive hubs by returning the center caps to their original orientation.

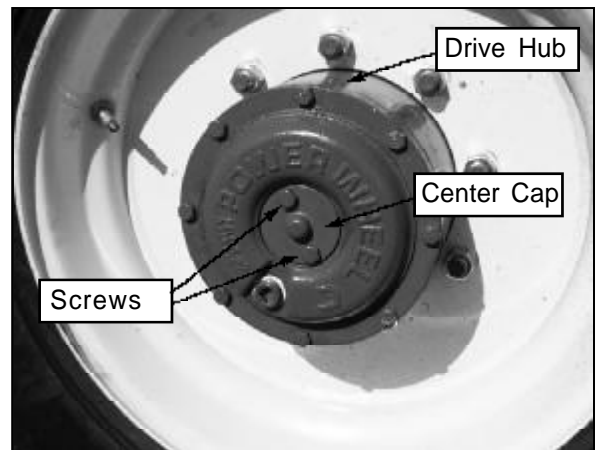


Figure 2-7: Drive Hub (Operating position shown)

## Switching Fuels (Gas / Propane Only)

1. With the engine running push the Fuel Selector Switch to the center position.
2. After the engine has quit running select the appropriate fuel supply.
3. Restart the engine.

## AFTER USE EACH DAY

1. Ensure that the platform is fully lowered.
2. Park the machine on level ground, preferably under cover, secure against vandals, children or unauthorized operation.
3. Turn the key switch to **OFF** and remove the key to prevent unauthorized operation.

# Transportation

## BY CRANE

### ⚠️ WARNING ⚠️

Stand clear of machine when lifting.  
Check specifications on back page, insure that crane and slings are of correct capacity to lift weight of unit.

1. Insure that boom is fully lowered and retracted.
2. Attach straps to chassis lifting lugs only. Insure that straps are adjusted properly to keep unit level when lifting.

## BY TRUCK OR TRAILER

1. Insure that boom is fully lowered and retracted.
2. Maneuver the machine onto bed of truck / trailer.
3. When winching, follow instructions for emergency towing on page 2-6. Attach winch cable to front tie down lugs.

### ⚠️ CAUTION ⚠️

Do not winch machine faster than 3 mph.

4. After winching, insure that all four drive hubs are engaged by returning the center caps to their original orientation.
5. Secure the machine to the transport vehicle using chains / straps of adequate load capacity (refer to specifications Table 1-1) attached to chassis tie down lugs. (see figures 2-8 and 2-10)
6. Place wooden block (4" x 4" x 36") under platform support braces as shown. (Figure 2-9)
7. Attach ratchet strap under platform floor grating, over support braces. (Figure 2-9) Do not over tighten.

### ⚠️ WARNING ⚠️

NEVER elevate the machine while on a truck or trailer.



Figure 2-8: Front chassis tie down lifting lugs.

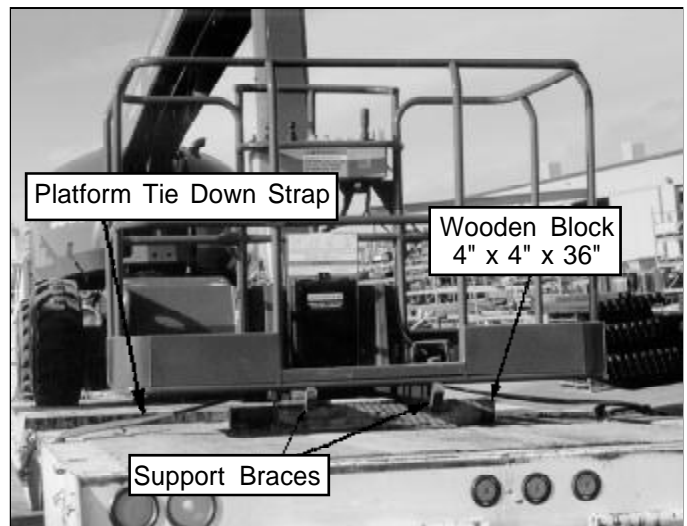


Figure 2-9: Securing the machine for transportation.



Figure 2-10: Rear chassis tie down lifting lugs.

# Maintenance

## FUELING

### Gasoline

1. Open left turret cover, open fill pipe cap. (see figure 2-11)
2. Fill to capacity with unleaded motor fuel only.
3. Fuel tank full capacity is 42 US gallons.

### Diesel

1. Open left turret cover, open fill pipe cap. (see figure 2-11)
2. Fill to capacity with diesel motor fuel only, grade #1-D, or #2-D. Use distillate fuel only, do not use residual or blend.
3. Fuel tank full capacity is 42 US gallons.

## HYDRAULIC OIL

1. Open left turret cover and check oil level at sight gauge with the boom stowed and retracted. Engine running or stopped. (see figure 2-12)
2. If necessary, fill to capacity with clean ISO compatible hydraulic oil.
3. Clean area around cap before opening.
4. Open filler / breather cap to add hydraulic oil.
5. Replace cap.

## LUBRICATION

Refer to service manual for lubrication chart and guidelines.



Figure 2-11: Fuel tank

## BATTERY MAINTENANCE



### WARNING



Hazard of explosive gas mixture. Keep sparks, flame and smoking materials away from batteries.

Always wear safety glasses when working with batteries.

Battery fluid is highly corrosive. Rinse away any spilled fluid thoroughly with clean water.

Check battery fluid level daily, especially if work platform is being used in a warm, dry climate.

If electrolyte level is lower than 3/8 in. (10 mm) above plates add distilled water only. DO NOT use tap water it will shorten battery life.

Keep terminals and top of battery clean.

## TIRES

Tire selection can affect the stability of the machine. Use only tires supplied by UpRight (15-19.5 NHS Tubeless 14 Ply Rating ) unless approved by the manufacturer in writing. Check tire air pressure daily. (80 psi) (5.5 bar)

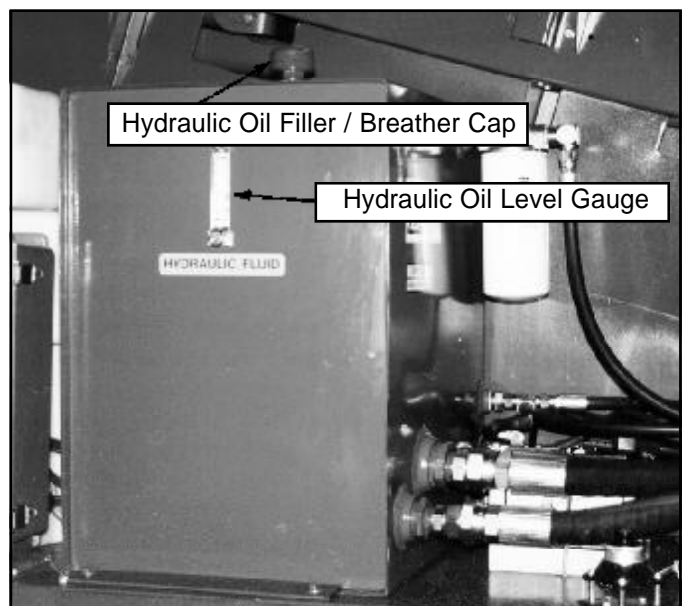


Figure 2-12: Hydraulic Oil Tank

## 3.0 Introduction



### WARNING



Be sure to read, understand and follow all information in the *Operation Section* of this manual before attempting to operate or perform service on any SB60 Work Platform.

This section contains procedures for the operation inspection, adjustment, scheduled maintenance, and repair/removal of the SB60.

*Section 2.0* will aid in understanding the operation and function of the various components and systems of the SB60 and help in diagnosing and repair of the machine.

Refer to Table 3-1, Preventative Maintenance Checklist, for recommended maintenance intervals.

**NOTE: Torque all hardware to torques listed on page 3-29 unless otherwise specified.**

## TERMINOLOGY

**TERMINAL BLOCKS:** Located in upper and lower control boxes. Designated by **TB##**. (##) designates the number of the block which is written on the terminal block. "R" right or "L" may follow the number.

**WIRE COLOR:** Indicated by **color/color**. First color refers to insulation color and second color indicates stripe. If second color is not given there is no stripe.

**FORWARD:** Front of machine indicated by yellow arrows on chassis.

**AFT:** Rear of machine indicated by orange arrows on machine.

## GENERAL PROCEDURES

**CONTACT BLOCKS:** Removed by inserting a flat screwdriver into the slot at either end of block and prying outward. Installed by pressing into an empty slot.

**SWITCH MOUNT BASE:** Assembled to back of switch actuator. Removed by rotating the small black lever counterclockwise and lifting off base.

**TERMINAL BLOCKS:** Remove wires by inserting a small flat bladed screwdriver into square beside wire. Install wires by stripping 1/2" of insulation, inserting screwdriver in square and inserting wire. Be sure no strands are bend backwards. Replace wires with same rating and type.

## SPECIAL TOOLS

The following is a list of special tools which may be required to perform certain maintenance procedures on the SB60 work platform.

- SuperFlex Optimizer (P/N 100329-000)
- Optimizer cord (P/N 100329-005)
- 0-1000 PSI Hydraulic Pressure Gauge with Adapter Fittings (UpRight P/N 014124-010)
- 0-3000 PSI Hydraulic Pressure Gauge with Adapter Fittings (UpRight P/N 014124-030)
- 0-6000 PSI Hydraulic Pressure Gauge with Adapter Fittings (UpRight P/N 014124-060)
- 0-30 Gallon Hydraulic Flow Meter With 0-3000 P.S.I. Simulated Load and Adapter Fittings (UpRight P/N 67040-000)
- Adapter Fitting (UpRight P/N 063965-002)
- Inclinometer (UpRight P/N 010119-000)
- Crimping Tool (UpRight P/N 028800-009)
- Terminal Removal Tool (P/N 028800-006)
- Deutsch Field Kit (Small) (P/N 030899-000)
- Deutsch Field Kit (Large) (P/N 030898-000)

## 3.1 Preventative Maintenance (Table 3-1)

The complete inspection consists of periodic visual and operational checks, together with all necessary minor adjustments to assure proper performance. Daily inspection will prevent abnormal wear and prolong the life of all systems. The inspection and maintenance schedule is to be performed at regular intervals. Inspection and maintenance shall be performed by personnel who are trained and familiar with mechanical and electrical procedures.

<b>!</b>	<b>WARNING</b>	<b>!</b>
<p>Before performing preventative maintenance, familiarize yourself with the operation of the machine.</p> <p>Always block the elevating assembly whenever it is necessary to perform maintenance while the platform is elevated.</p>		



Figure 3-1: Large Deutsch Field Kit



Figure 3-2: Small Deutsch Field Kit



# Maintenance

The preventative maintenance table has been designed to be used primarily for machine service and maintenance repair. Please photocopy this page and use the table as a checklist when inspecting the machine for service.

Preventative Maintenance Table Key

### Interval

- Daily=each shift or every day
- 50h/30d=every 50 hours or 30 days
- 250h/6m=every 250 hours or 6 months
- 1000h/2y=every 1000 hours or 2 years

- Y=Yes/Acceptable
- N=No/Not Acceptable
- R=Repaired/Acceptable

## Preventative Maintenance Report

Date: \_\_\_\_\_  
 Owner: \_\_\_\_\_  
 Model No: \_\_\_\_\_  
 Serial No: \_\_\_\_\_  
 Serviced By: \_\_\_\_\_  
 Service Interval: \_\_\_\_\_

**Table 3-1: Preventative Maintenance Checklist**

COMPONENT	INSPECTION OR SERVICES	INTERVAL	Y	N	R
Batteries	Check electrolyte level	Daily			
	Clean exterior	3M			
	Clean terminals	3M			
Engine Oil and Filter	Check level and condition	Daily			
	Check for leaks	Daily			
	Change oil and filter (Duel Fuel)	200H			
	Change oil and filter (Diesel)	500H			
Engine Fuel System	Check fuel level	Daily			
	Check for leaks	Daily			
	Replace fuel filter	6M			
	Check air cleaner	Daily			
Engine Coolant	Check coolant level (with engine cold)	Daily			
	Replace coolant	2Y			
Hydraulic Oil	Check oil level	Daily			
	Change filter	6M			
*See Note	Drain and replace oil with ISO 46 compatible oil	2Y			
Hydraulic System	Check for leaks	Daily			
	Check hose connections	30D			
	Check hoses for exterior wear	30D			
Emergency Hydraulic System	Check operation of emergency override power unit	Daily			
Controller	Check operation of all controls	Daily			
Control Cable	Check the exterior of the cable for pinching, binding or wear	Daily			
Platform Floor and Rails	Check fasteners for proper torque	Daily			
	Check welds for cracks	Daily			
	Check condition of platform	Daily			
	Check condition of anchorage points	Daily			
	Check condition of operators manual	Daily			
Tires	Check for damage	Daily			
	Check air pressure (80 psi [5.5 bar])	Daily			
	Check lug nuts (torque to 90 ft. lbs. [123 Nm])	30D			
Hydraulic Drive System	Check hydraulic drive motor operation	Daily			
	Check hose, fittings, and valve block for leaks	Daily			

\* ISO grade 46, for temperatures above 32F (0 C).

\* For colder climates: ISO grade 32, for temperature range of 0 F (-17C) up to 32F (0 C).

\* ISO grade 15, for temperatures below 0 F (-17C).

**Table 3-1: Preventative Maintenance Checklist (cont'd.)**

COMPONENT	INSPECTION OR SERVICES	INTERVAL	Y	N	R
Hydraulic Pump	Check for leaks at mating surfaces	30D			
	Check for hose fitting leaks	Daily			
	Check mounting bolts for proper torque	30D			
	Wipe clean	30D			
Torque Hubs	Check for leaks	Daily			
	Check Oil level	250H/6M			
	Change Oil after break-in	50H/30D			
	Change Oil (SAE 90 wt. gear oil)	2000h/2y			
	Torque hub mounting hardware to 190 ft/lbs	6M			
Steering System	Check hardware & fittings for proper torque	6M			
	Check linkage for wear areas	30D			
	Check for missing/loose retainers	30D			
	Check steering cylinder for leaks	Daily			
Elevating Assembly	Inspect for structural cracks	Daily			
	Check pivot points for wear	30D			
	Check pivot pin retaining bolts for proper torque	30D			
	Check members for deformation	Daily			
Chassis	Check hoses for pinch or rubbing points	Daily			
	Check component mounting for proper torque	6M			
	Check welds for cracks	Daily			
	Check swing bearing bolt (torque to 190 ft/lbs)	6M			
Lift Cylinders	Check the cylinder rods for wear	30D			
	Check pivot pin retaining bolts for proper torque	30D			
	Check seals for leaks	30D			
	Inspect pivot points for wear	30D			
	Check fittings for proper torque	30D			
Entire Unit	Check for and repair collision damage	Daily			
	Check fasteners for proper torque	3M			
	Check for corrosion-remove and repaint	3M			
	Lubricate	30D			
Labels	Check for peeling, missing, or unreadable labels & replace	Daily			
Turret	Check ring gear for proper lubrication and wear	Daily			
	Check planetary oil level	150H/3M			
	Check Lubricate ring gear (MoS <sub>2</sub> grease)	150H/3M			

### 3.2 Supporting Elevating Assembly (Figure 3-3)



#### WARNING



Never perform service on the work platform in the elevating assembly area while platform is elevated without first blocking the elevating assembly.

DO NOT stand in elevating assembly area while deploying or storing brace.

7. Push lower button and gradually lower platform until overhead hoist is supporting the elevating assembly.

#### Removal

1. Using chassis controls, gradually raise platform until boom is free of support.
2. Remove support.
3. Push lower button to completely lower platform.

#### Installation

1. Park the work platform on firm level ground.
2. Fully retract upper boom.
3. Verify platform emergency stop switch is ON.
4. Turn platform/chassis switch to **CHASSIS**.
5. Using the Elevate Boom Switch, elevate platform 8-12 inches.
6. Using an overhead hoist (preferred) or jackstand with minimum capacity of Two tons; Support the boom.

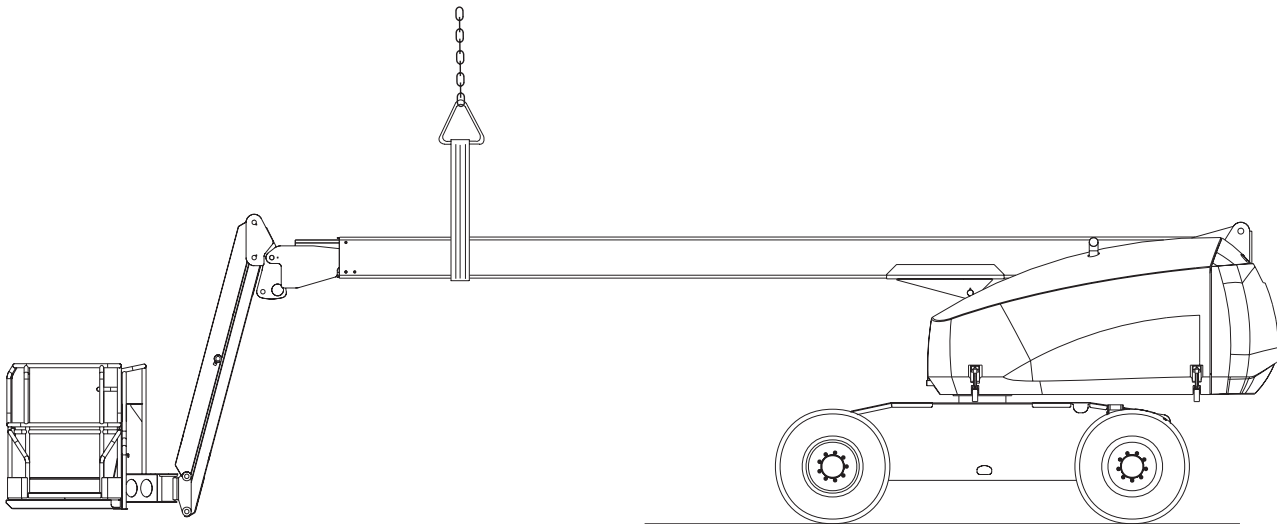


Figure 3-3: Supporting Elevating Assembly

## 3.3 Battery Maintenance

### **WARNING**

Hazard of explosive gas mixture. Keep sparks, flame, and smoking material away from battery.

Always wear safety glasses when working with batteries.

Battery fluid is highly corrosive. Thoroughly rinse away any spilled fluid with clean water.

### **BATTERY INSPECTION AND CLEANING**

Check battery fluid level daily, especially if work platform is being used in a warm, dry climate. If required, add distilled water **ONLY**. Use of tap water will shorten battery life.

The battery should be inspected regularly for signs of cracks in the case, electrolyte leakage and corrosion of the terminals. Inspect cables for worn spots or breaks in the insulation and for broken cable terminals.

Clean the battery when it shows signs of corrosion at the terminals or when electrolyte has overflowed during charging. Use a baking soda solution to clean the batteries, taking care not to get the solution inside the cells. Rinse thoroughly with clean water. Clean battery and cable contact surfaces to a bright metal finish whenever a cable is removed.

### **WARNING**

Hazard of explosive gas mixture. Keep sparks, flame, and smoking material away from battery.

Always wear safety glasses when working with batteries.

Battery fluid is highly corrosive. Thoroughly rinse away any spilled fluid with clean water.

## **BATTERY CHARGING**

### **WARNING**

Charge the battery only in a well ventilated area.

Do not charge the battery when the work platform is in an area containing sparks or flames.

Permanent damage will result if the battery is not immediately recharged after discharging.

Never leave the charger unattended for more than two days.

Never disconnect the cables from the battery when the charger is operating.

Keep the charger dry.

Charge battery as follows:

1. Check the fluid level. If the electrolyte level is lower than 3/8 in. (10mm) above the plates, add clean, distilled water only.
2. Connect the charger plug to a properly grounded outlet of the proper voltage and frequency.
3. Use a charger which turns off automatically when the batteries are fully charged.

### 3.4 Lubrication

Refer to Table 3-1 for the lubrication intervals and Figures 3-4 and 3-5 for location of items that require lubrication service. Refer to the appropriate sections for lubrication information on the Steering Linkage, Torque hubs, Hydraulic Oil, Filter, and Engine Oil and Filter.

#### GREASE FITTINGS

Wipe each grease fitting before and after greasing. Using multipurpose grease in a grease gun, pump the grease into the fitting until grease just begins to appear at the edges of the pivot, wipe off any excess grease.

#### HYDRAULIC OIL AND FILTER

##### Fluid Level

With the platform fully lowered, check oil level on sight gauge. If the oil is NOT in operating range, add hydraulic fluid until oil is visible in operating range on dipstick or visible in sight gauge. DO NOT fill above operating range or when the platform is elevated.

##### Oil and Filter Replacement

1. Operate the platform for 10-15 minutes to bring the hydraulic oil up to normal operating temperature.

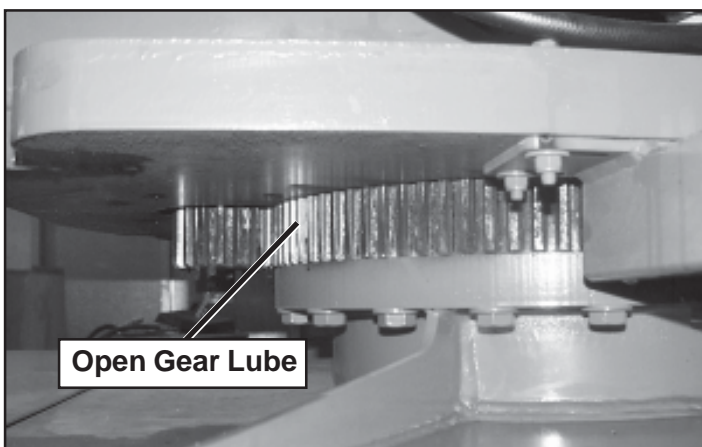


Figure 3-4: Slew Gear

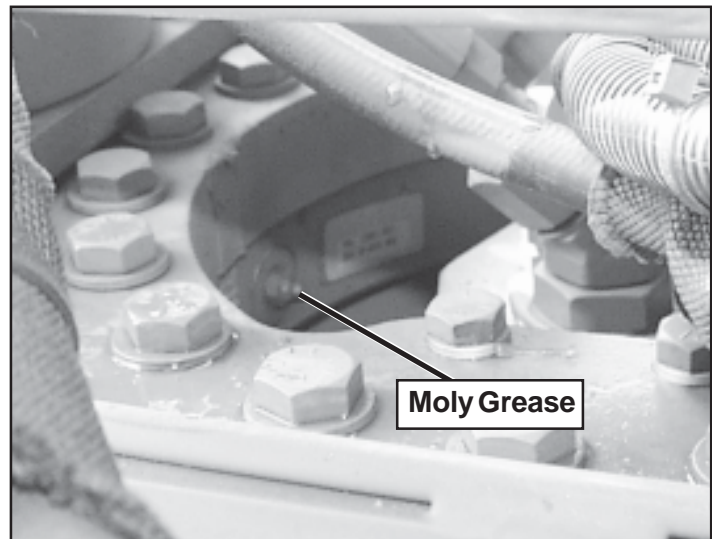


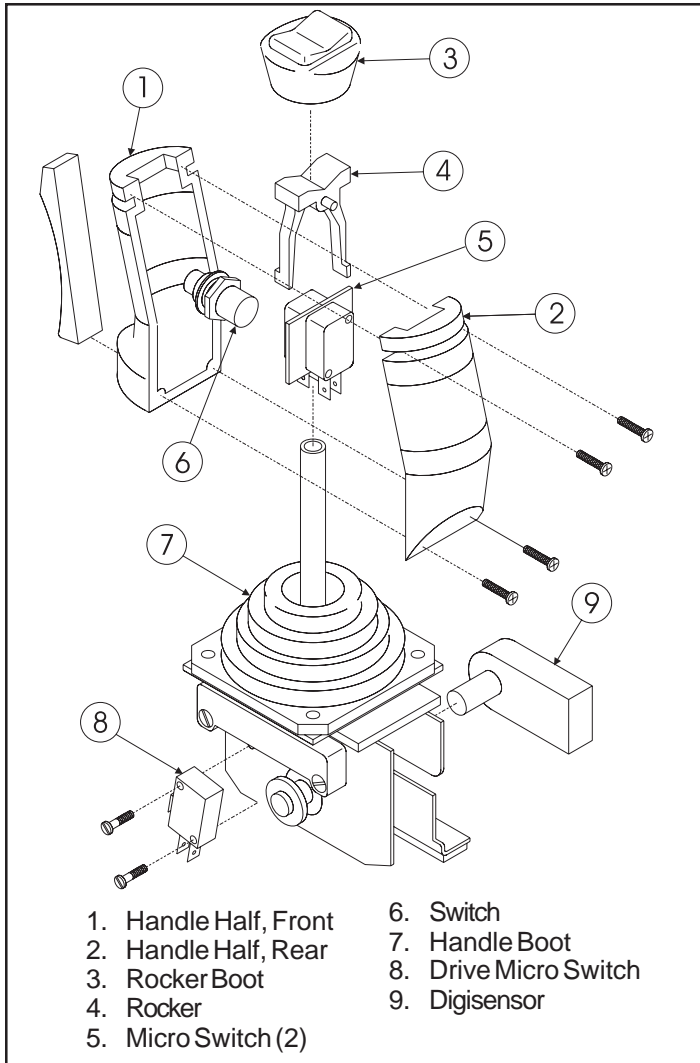
Figure 3-5: Slew Gear Grease Fitting

#### ⚠ CAUTION ⚠

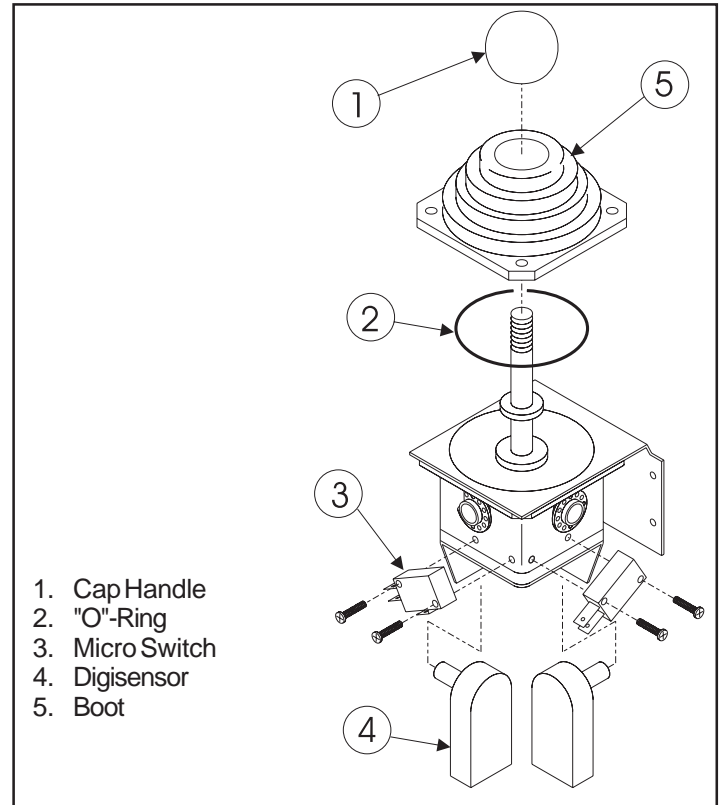
The hydraulic oil may be hot enough to cause burns. Wear safety gloves and safety glasses when handling hot oil.

2. Provide a suitable container to catch the drained oil.
3. Remove the drain plug and allow all oil to drain into the container. Be sure to dispose of oil properly.
4. Reinstall the drain plug.
5. Remove filter element from filter head (located beside valve block).
6. Apply a thin film of clean hydraulic oil (ISO No. 46) to the gasket of the replacement filter.
7. Thread replacement filter onto the filter head until the gasket makes contact then rotate 3/4 of a turn further.
8. Fill the hydraulic oil tank to operating level on sight gauge with ISO #46 hydraulic oil.

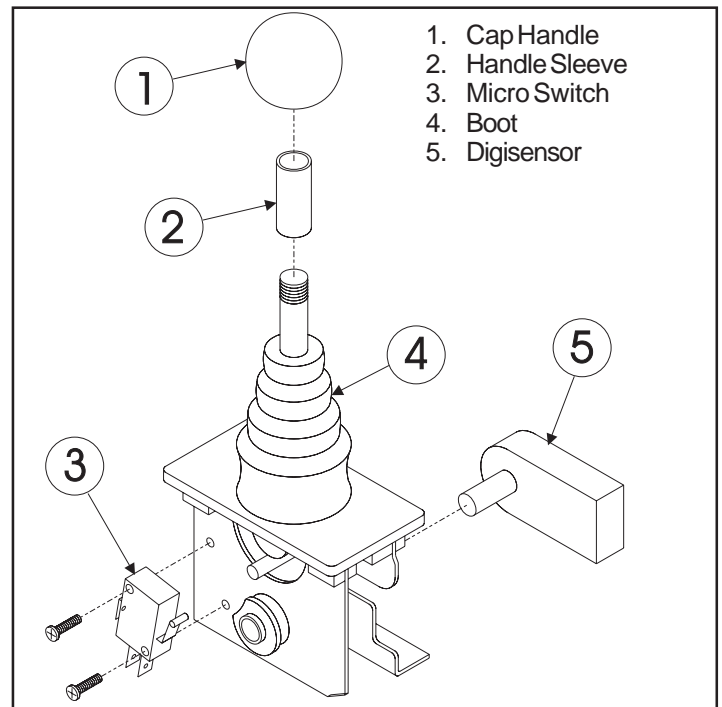
**NOTE: For service information on the engine refer to your engine manual (located in platform manual box or available from UpRight Inc.).**



**Figure 3-6: Proportional Controller**



**Figure 3-7: Lift Controller**



**Figure 3-8: Boom Extend Controller**

## 3.5 Proportional Controllers

### JOYSTICK HANDLE

#### (FIGURES 3-3 THRU 3-5)

1. If necessary, remove handle assembly from controller box.
2. Remove and replace defective parts.
3. If replacing Digisensor, adjust Digisensor to neutral (both LED's on) when joystick is centered.

**NOTE: Check that controller operates correctly when handle is pushed completely forward and reverse.**

Refer to pages 6-50 (Gas) and 6-54 (Diesel) for repair part numbers.

## Superflex Controller

The SuperFlex controller is adjusted at the factory. If problems are suspected with the controller, use the optimizer (P/N 100329-000) to check for proper controller settings.

1. Check that proper voltage is supplied to the controller.
2. Be sure all cables and wiring are properly connected..
3. Be sure ground wiring is in good condition.
4. Be sure all machine interlock switches are working properly.

There are three LED's on the controller.

The CPU (CenterLED) flashes if the system is O.K.

If the center LED is on steady the controller must be replaced.

The INPUT LED (Left LED) flashes whenever one or more joysticks is activated.

If the INPUT LED does not flash when a joystick is activated, check the wiring for the joystick.

If the INPUT LED is on steady there is a short (+12 volts) to the joystick.

The OUTPUT LED (right LED) flashes when an output signal is active.

If the OUTPUT LED is on steady there is a short to the output function.

## Superflex Optimizer (Figure 3-10)

Use the Optimizer to test the operation of the controller and joysticks. SB60 presets are shown.

1. Plug the Optimizer with cord into the controller.
2. Operate each machine function. The Optimizer will display each setting.
3. If the function is out of adjustment, use the plus and minus adjustment keys on the optimizer to reset to the proper setting.

**NOTE: Be sure to press RUN key after making adjustments or the new setting will be lost.**

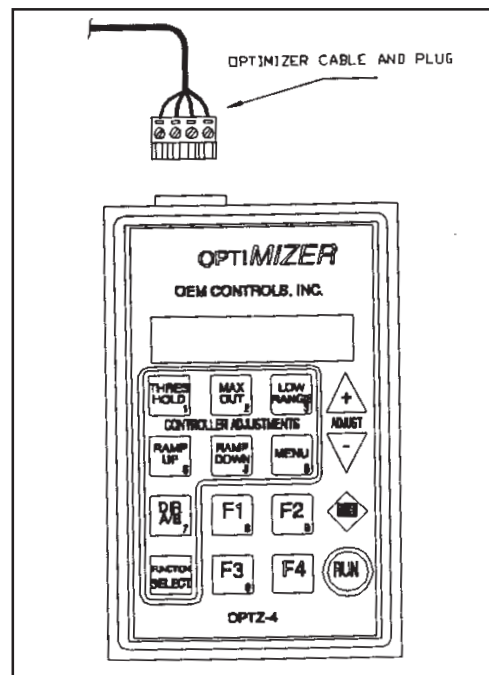


Figure 3-9: Optimizer

**SUPERFLEX PRESETS:**

FUNCTION	MAX	THRESHOLD	RAMP ON	RAMP OFF
EXTEND	95%	40%	0.5	0.2
RETRACT	95%	40%	0.5	0.2
LIFT, UP	95%	34.5%	0.5	0.2
LIFT, DOWN	95%	28%	0.5	0.2
SWING, LEFT/RIGHT	80%	32.5%	0.5	0.5
DRIVE, FWD./REV.	65%	28%	0.8	0.8
DUAL RANGE	33%			

STOPPING DISTANCE NOT TO EXCEED 6.5 FEET

**ADJUSTMENTS TO BE MADE FROM THESE PRESETS BASED ON SPEED MEASUREMENTS.**

**SPEED MEASUREMENTS:**

BOOM FUNCTIONS LIFT AND EXTEND OPERATED SIMULTANEOUSLY ELEVATING TO FULL HEIGHT AND RETURNING TO STOWED POSITION.  
 FULL CYCLE TIME: 115-135 SEC.  
 HALF CYCLE, UP: 60-70 SEC.  
 HALF CYCLE DOWN: 55-65 SEC.

BOOM FUNCTIONS OPERATED INDIVIDUALLY.  
 EXTEND: 55-65 SEC.  
 RETRACT: 30-45 SEC.  
 LIFT: 60-65 SEC.  
 LOWER: 50-60 SEC.

TURNTABLE (TURRET) ROTATE:  
 FULL 360° ROTATION; 90 SEC. FULL 360±5 SEC.

JIB UP/DOWN:  
 40/30 SEC. ±5 SEC.  
 FLOW CONTROL ON MAIN VALVE BLOCK.

PLATFORM ROTATE:  
 16 SEC. ±2 SEC.  
 FULL 180° ROTATION  
 FLOW CONTROL ON VALVE BLOCK IN JIB BOOM.

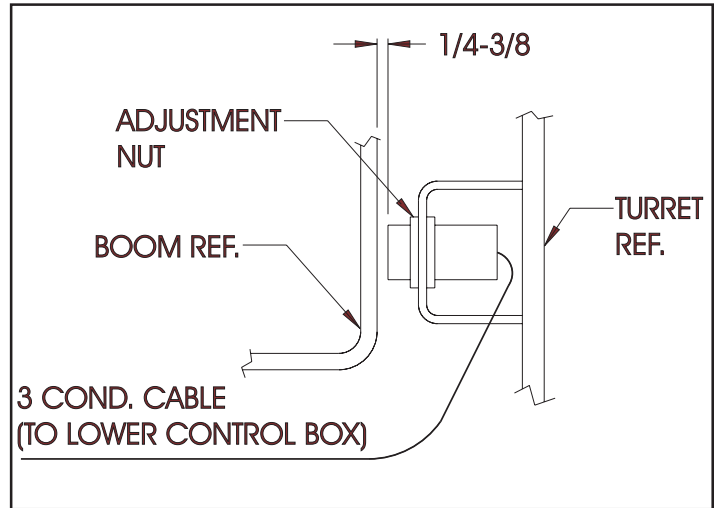
STEER:  
 LOCK TO LOCK 7 SEC. ±1 SEC.

DRIVE SPEEDS:

	SPEED	20 FT. TIME
HIGH SPEED	3.8 TO 4.2 MPH	3.6 TO 3.2 SEC.
LOW SPEED	0.5 TO 0.7 MPH	27.3 TO 19.5 SEC.

## 3-6 Boom Proximity Switch (Figure 3-6)

The Platform Down Switch bypasses the Tilt Sensor when the platform is fully lowered and closes the circuit to the Platform Down Relay, which allows high speed travel, cage trim function and turret rotation.



**Figure 3-10: Proximity Switch**

**⚠ WARNING ⚠**

DO NOT attempt to adjust Limit Switches without first blocking the elevating assembly (see section 3.1).

1. Lower the Platform completely.
2. With the Platform / Chassis switch on Chassis, push the Tilt Sensor base to test the alarm circuit.
3. If the alarm sounds, elevate the platform and adjust the position of the switch 1/4" to 3/8". Lower the platform and retest. If down limit switch is properly adjusted, the tilt alarm will not sound.
4. With platform elevated, repeat step 2. When switch is properly adjusted, alarm will sound.

### 3.7 Tilt Sensor (Figure 3-7)

The Tilt Sensor has three wires; red-power (12v in), black-ground, and white-output (12v out) . To verify the sensor is working properly there are two LED's under the sensor; green indicates the sensor is on (has power), red indicates the sensor is level and the white wire is 'hot' (12v out).

1. Check tires for proper pressure.
2. Place machine on firm level surface  $\pm 1/4^\circ$ .
3. Use Inclinometer to ensure that the front and rear of the chassis are level within  $\pm 1/4^\circ$ .
4. Adjust the three leveling locknuts until the bubble is centered in the circle on the attached bubble level.
5. Elevate the platform until down limit switch opens and push the tilt sensor base to test the alarm circuit. Alarm should sound.

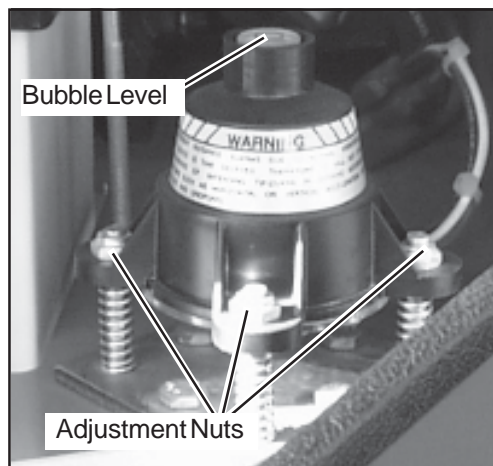


Figure 3-11: Tilt Sensor

### 3.8 Hydraulic Manifold (Figure 3-12)

It is not necessary to remove the manifold to perform all maintenance procedures. Prior to performing maintenance, determination if the manifold needs to be removed.

#### REMOVAL

1. Disconnect the battery.
2. Tag and disconnect the solenoid valve leads from the terminal strip.
3. Tag, disconnect and plug hydraulic hoses.
4. Remove the bolts that hold the manifold to the mounting bracket.
5. Remove manifold block.

#### DISASSEMBLY

**NOTE: Mark all components as they are removed so as not to confuse their location during assembly. Refer to Figure 3-12 often to aid in disassembly and assembly.**

1. Remove coils from solenoid valves.
2. Remove spool valve cover and spool valve.
3. Remove solenoid valves, lift relief valve, counterbalance valves and divider combiner valve.
4. Remove fittings, plugs, springs, balls and orifices.

#### CLEANING AND INSPECTION

1. Wash the manifold in cleaning solvent to remove built up contaminants and then blow out all passages with clean compressed air.
2. Inspect the manifold for cracks, thread damage and scoring where O-rings seal against internal and external surfaces.
3. Wash and dry each component and check for thread damage, torn or cracked O-rings and proper operation.
4. Replace parts and O-rings found unserviceable.

#### ASSEMBLY

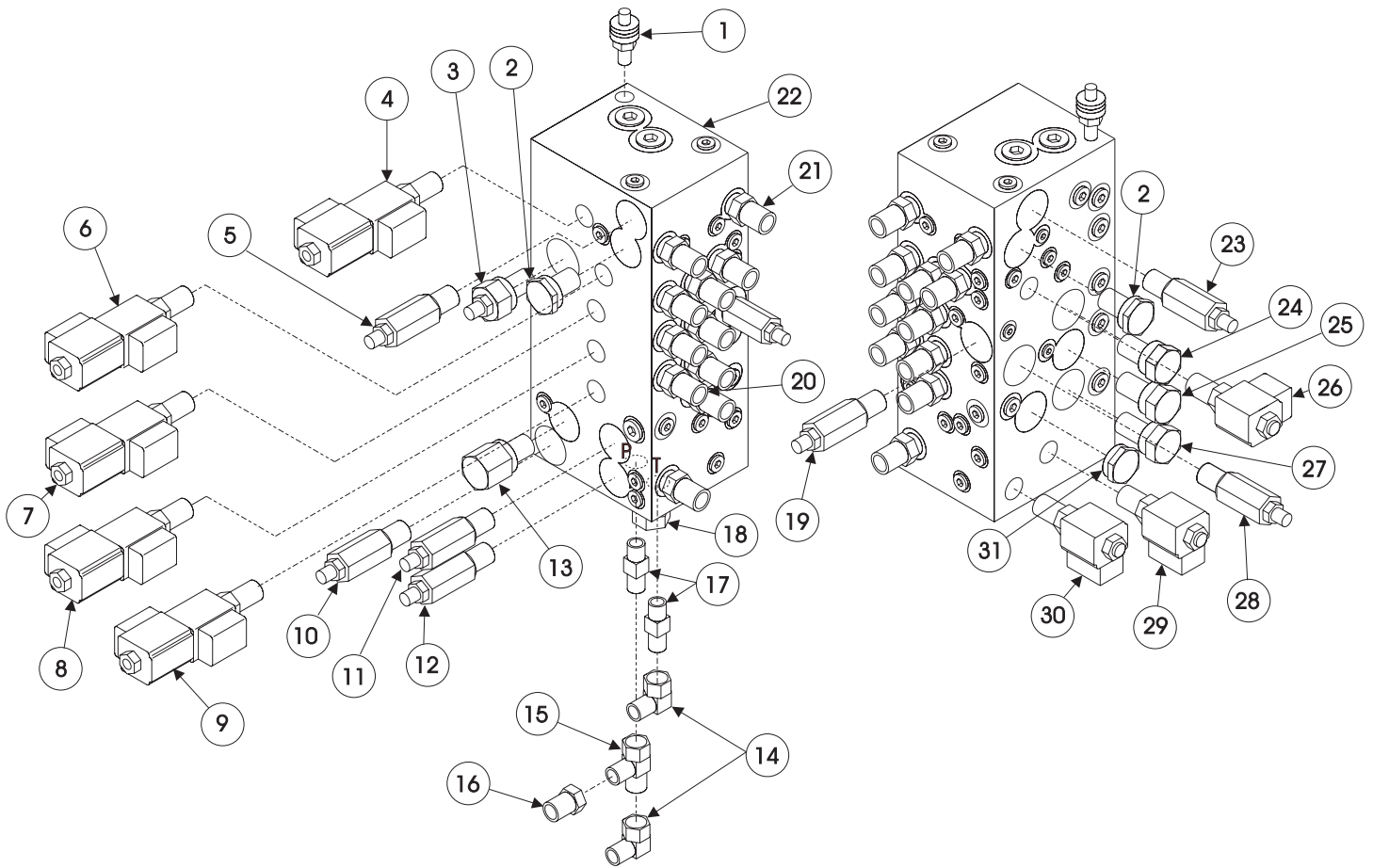
**NOTE: Lubricate all O-rings before installation to prevent damage to O-rings. Seat all balls in manifold block by lightly tapping on the ball with a brass drift punch.**

1. Install fittings, plugs, springs, balls and orifices. Use one drop of Locktite #242 on each screw-in orifice.
2. Install solenoid valves, lift relief valve, counterbalance valves, divider combiner valve, and spool valve.
3. Install coils on solenoid valves.

#### INSTALLATION

1. Attach manifold assembly to mounting plate with bolts.
2. Connect Solenoid leads to terminal strip (as previously tagged).
3. Connect hydraulic hoses. Be certain to tighten hoses to manifold.
4. Reconnect the battery.
5. Operate each hydraulic function and check for proper operation and leaks.
6. Adjust lift relief and counterbalance valve pressures according to instructions in Section 3-9.





- |                                 |                          |
|---------------------------------|--------------------------|
| 1. Pressure Test Port           | 16. Fitting              |
| 2. Check Valve                  | 17. Fitting              |
| 3. Flow Control Valve           | 18. Shuttle Valve        |
| 4. Steering                     | 19. Relief Valve         |
| 5. Steer Left Relief            | 20. Fitting              |
| 6. Cage Level                   | 21. Fitting              |
| 7. Swing (Turret)               | 22. Valve Block          |
| 8. Lift Boom                    | 23. Steer Right relief   |
| 9. Boom Extend                  | 24. Compensator          |
| 10. Main Relief                 | 25. Compensator          |
| 11. High Pressure Extend Relief | 26. Boom Power           |
| 12. Low Pressure Extend Relief  | 27. Compensator          |
| 13. Bypass Valve                | 28. Boom Lift Relief     |
| 14. Fitting                     | 29. Dump                 |
| 15. Fitting                     | 30. High Pressure Extend |
|                                 | 31. Check Valve          |

**Figure 3-12: Hydraulic Manifold**

### 3.9 Drive Pump Settings (Figure 3-13)

**NOTE:** Pump is properly adjusted at factory. Pump settings should only be checked if pump failure is suspected.

#### MAIN RELIEF VALVES

Main relief valves "A" and "B" should be bench tested off the machine.

**NOTE:** Main relief valves should be adjusted to 5300 PSI.

#### PUMP REMOVAL

1. Mark, disconnect and plug the hose assemblies.
2. Mark and disconnect the electric cables.
3. Remove hardware which secures pump and remove from machine.

#### PUMP INSTALLATION

1. Install pump using hardware previously removed.
2. Unplug and reconnect the hydraulic hoses.
3. Reconnect the electric cables.
4. Fill the tank with clean hydraulic fluid.
5. Check the oil level in the hydraulic tank before operating the work platform.
6. Operate the pump and check for leaks and proper operation.
7. Replenish hydraulic fluid if necessary.

**IMPORTANT:** If replacing the pump, be sure the pump and hydraulic tank are filled with oil before starting the engine. Damage to the pump may occur if it is run without first being filled with oil.

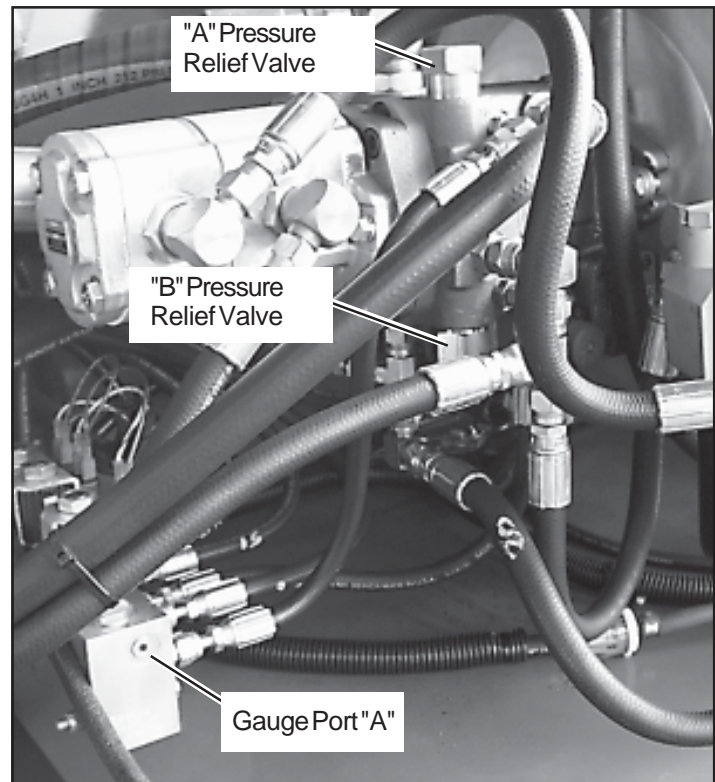


Figure 3-13: Hydraulic Pump

## 3.10 TORQUE HUBS

**Note:** Change fluid in torque hubs after the first 50 hours of operation. Change every 1000 hours thereafter.

### *Changing Fluid*

**NOTE:** It is not necessary to remove torque hub to change fluid.

1. Raise axle using an Eight ton hydraulic jack. Place Eight ton jackstands under each end of axle.
2. Remove wheel and rotate torque hub so drain plug on side is at bottom of hub.
3. Remove drain plugs at bottom of hub and front cover and drain oil from unit.
4. Rotate hub so plug opening in front cover is slightly above half full position and side plug opening is at the top.
5. Fill unit with 90 wt. gear oil until oil comes out front plug opening (torque hub must be 1/2 full).
6. Replace plugs.
7. Install wheel and lower machine to the ground.

### *Torque Hub Removal*

1. Park the work platform on firm level ground and block the wheels to prevent the work platform from rolling.
2. Disconnect battery negative terminal.
3. Loosen the wheel lug nuts on the torque hub to be removed.
4. Raise the axle of the work platform using a 8-ton jack.
5. Position two 8-ton jack stands under the axle to prevent the work platform from falling if the jack fails.
6. Remove the wheel nuts and wheel.
7. Disconnect hydraulic brake line from brake.



### **CAUTION**



Clean all fittings before disconnecting the hose assemblies.

Plug all port holes and hose assemblies **IMMEDIATELY** to prevent contamination from dust and debris.

8. Mark and remove hoses from drive motor.
9. Remove mounting bolts from drive motor.
10. Separate drive motor from brake. Discard gasket.
11. Separate brake from torque hub. Discard gasket.
12. Remove 1/2-20 nuts and washers from torque hub.
13. Remove torque hub.

### *Installation*

**NOTE:** Torque all hardware to torques listed on page 3-28 unless otherwise specified.

1. Install the torque hub using hardware previously removed.
2. Using SAE 90W weight gear lube fill torque hub. Torque hub must be half full.
3. Install new gasket and brake.
4. Install new gasket and drive motor.
5. Secure assembly using washers and bolts.
6. Connect hydraulic brake lines.
7. Connect hoses to drive motor.
8. Install wheels. Torque lug nuts to 160ft. lbs. (217 Nm).
9. Bleed brake lines if necessary.
10. Remove jack stands and lower rear end.
11. Connect battery terminal.
12. Operate machine and check for proper operation of torque hub. Check function of brake.

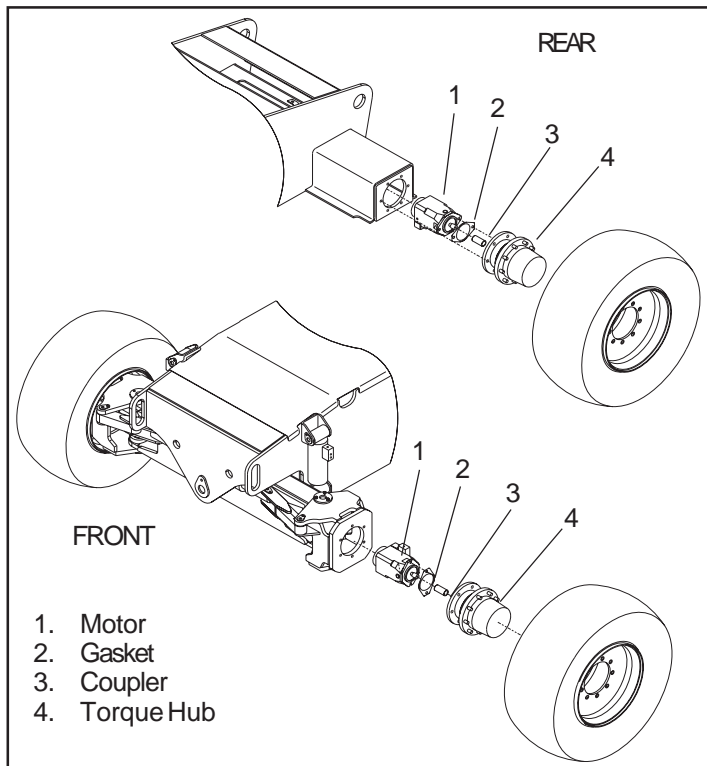


Figure 3-14: Torque Hub Assembly

### DISASSEMBLY OF TORQUE HUB (REFER TO FIG. 3-15)

1. Slide the coupling (1) from splines on input shaft (2).
2. Position the assembly upright on face of spindle (3).
3. Remove the disengage cover (31) if necessary.
4. Remove eight bolts (29) and the large cover (28) from the unit. The thrust washer (25) and the disengage plunger (26) usually remain attached to the large cover (28) when it is removed. Remove thrust washer (25), disengage plunger (26) and "O" ring (27) from the large cover (28).
5. Remove primary sun gear (24) from end of input shaft (2).
6. Remove the primary carrier assembly (22).
7. Remove the secondary carrier assembly (21).
8. Remove the input shaft (2) from spindle (3). Remove the retaining rings (17), washers (18), and disengage spring (19) from input shaft (2) only if replacement is required.
9. One tab of lock washer (15) will be engaged in slot of bearing nut (16); bend back to release. Remove the bearing nut (16), lock washer (15) and thrust washer (14).

**Note:** A special locknut wrench is required for the removal of the bearing locknut. The Bearing Locknut Tool, Bearing Cone Driver and Spindle/Shaft Drive Tool are included in Service Kit, part number 100254-020.

10. Bolt Spindle Drive Tool, (Service Kit #100254-020), to ring gear (20). Grade 8 bolts should be used. Drive spindle (3) from hub (11) by turning center bolt of Spindle Drive Tool. Care should be taken to avoid damaging splines and threads on spindle.

**Note:** Bearing cone (13) has been designed with a press fit with respect to spindle (3). Considerable force will be required to remove cone from spindle.

11. Remove Spindle Drive Tool from ring gear (20).
12. Remove the eighteen bolts (9) and washers (10) from hub (11) and remove ring gear (20). It may be necessary to strike ring gear (20) with a rubber mallet to loosen from hub (11).
13. Remove the boot seal (4) and oil seal (5) and bearing cones (6 & 13) from hub (11). Inspect bearing cups (7 & 12) in position and remove only if replacement is required.

### ASSEMBLY OF TORQUE HUB

1. Press new bearing cups (7 & 12) in each side of the hub (11). It is recommended that bearing cups (7 & 12) and cones (6 & 13) be replaced in sets.
2. Assemble bearing cone (6) into cup (7) at seal end of hub (11) and press a new seal (5) into hub (11). Install boot seal (4) on hub (11) if unit is so equipped.
3. Position spindle (3) upright on bench. Lubricate lips of seal (5) and lower hub (11) onto spindle (3). Hub (11) should be centered as it is lowered over spindle (3) to prevent seal damage.
4. Assemble bearing cone (13) over spindle (3). Press bearing cone (13) over spindle bearing journal using press and cylindrical Bearing Cone Driver (Service Kit #100254-020). Press bearing cone (13) down until rollers just touch cup (12). Take care to avoid pressing cone (13) to far. **Note: If a press is not available, place Bearing Cone Driver tool over splined end of spindle (3) on the edge of bearing cone (13) and drive into place with hammer or mallet. If this method is used, care must be taken to avoid damage to bearing cone and spindle.**
5. Install thrust washer (14) with tab in keyway of spindle and bearing nut (16). **DO NOT install lock washer (15) at this time.**
6. Clean mating surfaces and apply a bead of silicone sealant to face of hub (11) that mates with ring gear (20). See instructions on sealant package. Hub (11) is attached to ring gear (20) with 18 3/8-24 grade 8 hex head cap screws (9) and flat washers (10). Torque cap screws to 52-50 lb.-ft. (70-81 Nm).

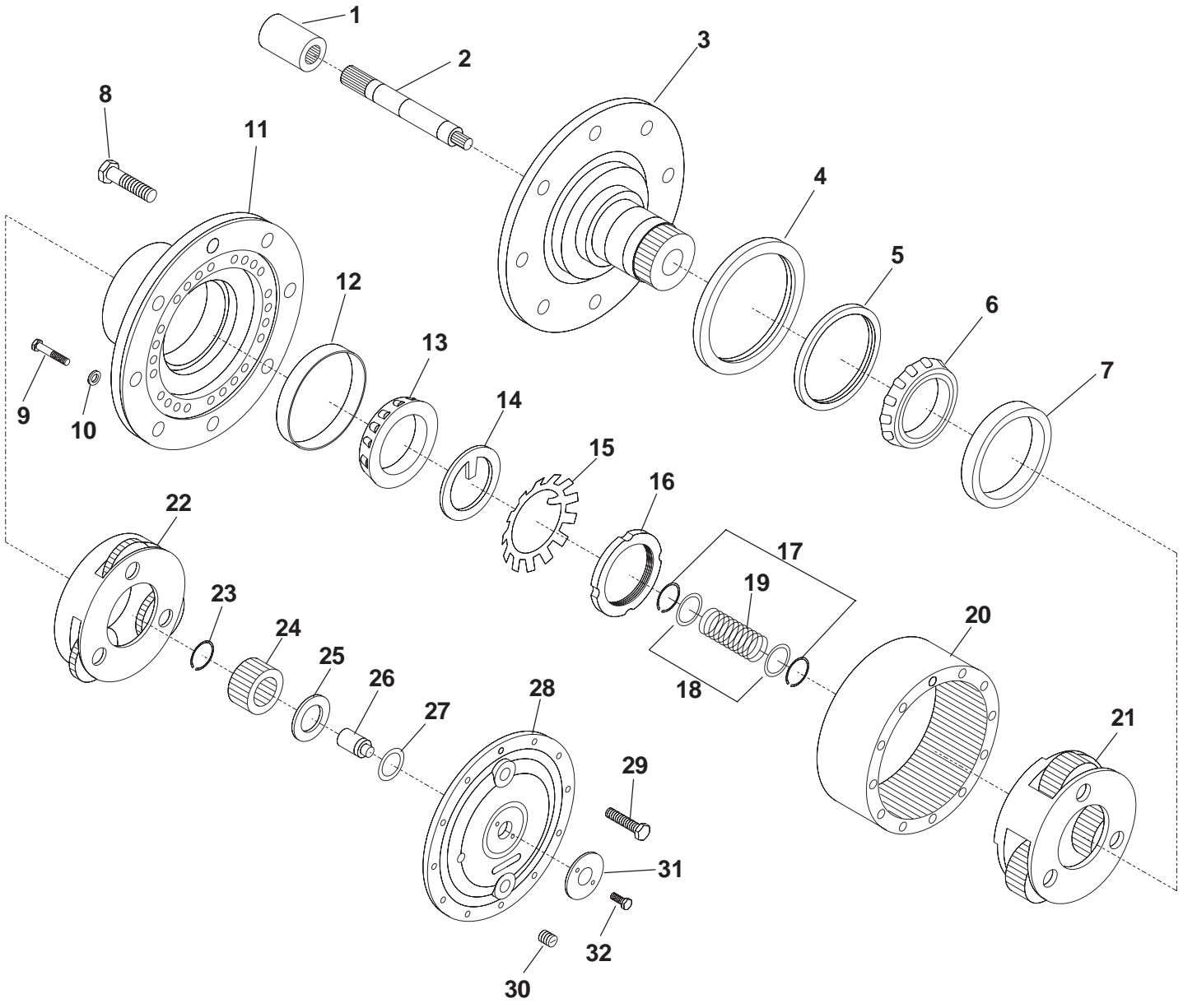
7. Place Spindle Drive Tool (Service Kit #100254-020), over spindle (3) and bolt or pin to ring gear (20). Make sure center bolt of Drive Tool is not touching spindle and is prevented from rotating by jam nuts provided on tool.
8. Check initial rolling torque by installing a lb.-in. torque wrench (arm or dial type) on center nut of Spindle Drive Tool and turning hub (11) slowly and steadily with the torque wrench. Note mean torque. An initial bearing torque of greater than 52 lb.-in. with boot seal installed or 46 lb.-in. without boot seal means that the cone (13) was pressed on to tightly in step 4. In this case, back off bearing cone (13) by pressing spindle (3) out of cone (13) until initial preload is relieved. See step 10 of disassembly procedure.
9. Torque bearing nut (16) with Bearing Locknut Tool (Service Kit #100254-020) until a bearing rolling torque of 42-50 lb.-in., with a boot seal installed, or 38-46 lb.-in., without a boot seal is reached. This may require several trials of pressing the cone (13) by torquing the nut (16) and then checking the rolling torque. Rotate hub (11) by hand as nut is being tightened in order to seat bearings.  
**NOTE: Up to 250 lb.-ft. of torque may have to be applied to bearing nut (16) in order to press cone (13) into position.**
10. Remove bearing nut (16) and install lock washer (15). Replace bearing nut (16).
11. Re-torque bearing nut (16) to 60-70 lb.-ft. (80-90 Nm.)
12. Secure bearing nut (16) by bending a lock washer (15) tab into one of four bearing nut slots. If no tab aligns with a slot, the nut may be tightened until one of the slots aligns with a lock washer tab.
13. Assemble a washer (18), spring (19), a second washer (18), and a retaining ring (17) in the middle grooves of input shaft (2). Install a second retaining ring (17) in groove near small end of input shaft (2).
14. Assemble the splined end of the input shaft (2) down into spindle (3).
15. Assemble the secondary carrier assembly (21) to spindle (3) at splines.
16. Assemble the primary carrier assembly (22) into the ring gear (20). It will be necessary to rotate carrier to align secondary sun gear {part of primary carrier assembly (22)} with planet gear teeth in secondary carrier assembly (21). Assemble primary sun gear (24) over input shaft (2). Rotate primary sun gear (24) to align input shaft (2) to gear splines and gear teeth in primary carrier assembly (22).
17. Lubricate "O" ring (27) and assemble in groove inside cover hole, push disengage plunger (26) into cover (28) with pointed end facing inside of unit.
18. Assemble the thrust washer (25) with tangs engaged with cover (28). **NOTE: A small amount of grease applied to the back side of thrust washer (25) will hold washer in place.** Apply a bead of silicone sealant to end of face of ring gear (20). Assemble cover (28) aligning holes of cover and ring gear. Assemble the eight 5/16-18 x 1 inch hex head bolts (29). Torque bolts to 20-25 lb.-ft. (27-34 Nm).
19. Assemble the disengage cover (31) with dimpled center protruding out if wheel is to be used to drive the vehicle. Assemble and torque the two 5/16-18 x 1/2 inch bolts (32). Torque bolts to 10-20 lb.-ft. (13-27 Nm).
20. Invert the torque hub assembly and assemble the coupling (1), with counterbore out, to the input shaft (2).
21. After motor is assembled to drive or drive is sealed at spindle, fill with lubricant to proper level and replace all plugs.

## **CARRIER ASSEMBLIES**

Do not attempt to to service primary or secondary carrier assemblies.

## **SEALING COMPOUND**

Silastic RTV732 sealer and General Electric Silimate RTV No. 1473 or RTV No. 1503 are currently recommended for sealing gasket surfaces. Sealant should be applied in a continuous bead, which should be centered on the surface to be sealed but should move to the inside of the hole at each bolt hole location.



- 1. Coupling
- 2. Input Shaft
- 3. Spindle
- 9. Hex Head Bolt (Grade 8)
- 10. Flat Washer
- 11. Hub
- 16. Bearing Nut
- 17. Retaining Ring
- 18. Washer
- 19. Disengage Spring
- 20. Ring Gear
- 21. Secondary Carrier Assy.
- 22. Primary Carrier Assy.
- 23. Retaining Ring
- 24. Primary Sun Gear
- 26. Disengage Plunger
- 28. Large Cover
- 29. Hex Head Bolt
- 30. Magnetic Plug
- 31. Disengage Cover
- 32. Hex Head Bolt
- 33. Quick Disconnect Gasket
- 34. Quick Disconnect Assy.
- 35. Hex Head Bolt

Service Kit (100254-020) contains:

4. Boot Seal	12. Bearing, Cup
5. Oil Seal	13. Bearing, Cone
6. Bearing, Cone	14. Thrust Washer
7. Bearing, Cup	15. Lock Washer
8. Wheel Bolt	25. Thrust Washer
	27. O-Ring

**Figure 3-15: Torque Hub**

## 3.11 Setting Hydraulic Pressures

Figure (3-16,3-17) shows complete hydraulic manifold assembly.

**Note:** Check hydraulic pressures whenever the pump, manifold or any relief valve has been serviced or replaced.

### MAIN RELIEF VALVE

1. Operate the hydraulic system 10-15 minutes to warm the oil.
2. Install a 0-3000 PSI pressure gauge to the pressure testport.
3. Retract boom completely.
4. While activating the boom retract function, set the pressure to 2700 PSI (186 bar) maximum by slowly turning the adjusting screw. Turning the adjusting screw clockwise increases pressure and counterclockwise decreases pressure.
5. Remove the pressure gauge and reinstall all plugs.

### OTHER RELIEF VALVES

1. Operate the hydraulic system 10-15 minutes to warm the oil.
2. Install a 0-3000 PSI pressure gauge to the pressure testport.
3. Completely extend function to be checked.
4. Continue activating function and set the pressure by slowly turning the adjusting screw until the correct pressure reads on the pressure gauge. Turning the adjusting screw clockwise increases pressure and counterclockwise decreases pressure.
5. Remove the pressure gauge and reinstall all plugs.

### COUNTERBALANCE RELIEF VALVES

1. If any counterbalance relief valve is faulty, completely lower the jib, and retract the boom.
2. Replace or recalibrate the counterbalance valve.
3. Slowly cycle function related to replaced counterbalance valve several times to remove air from system.

#### SPECIFICATIONS AND ADJUSTMENTS

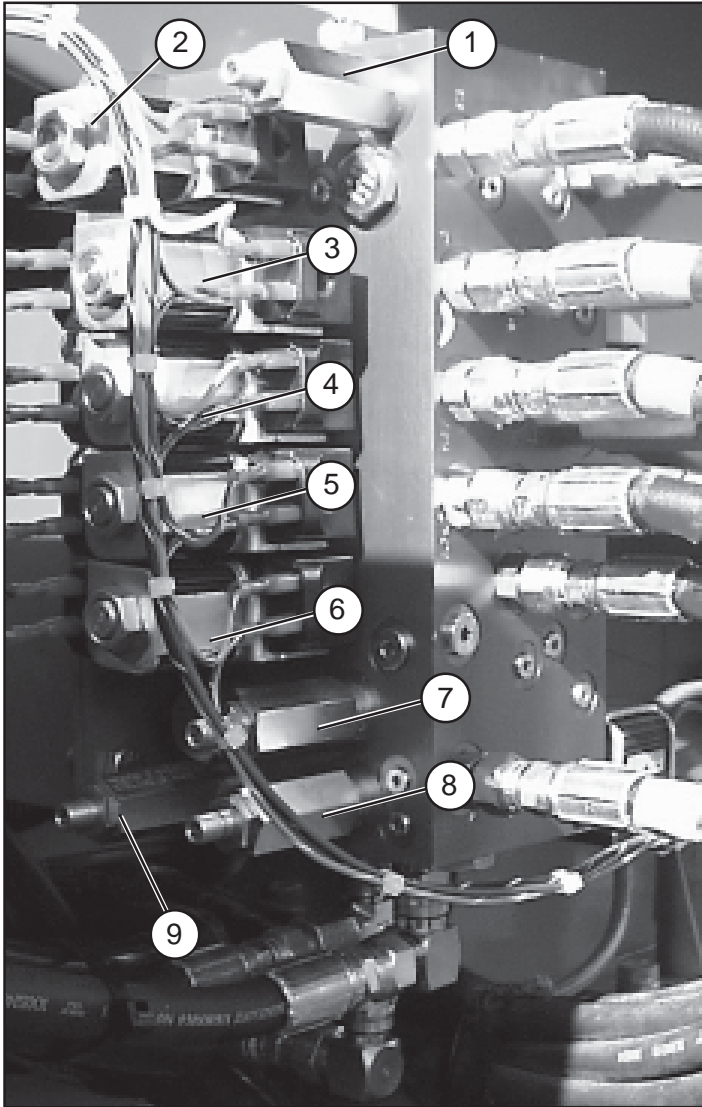
##### HYDRAULIC PRESSURE:

##### COUNTERBALANCE VALVES; (VALVES PRESET)

LIFT	3000 PSI	
SWING	1000 PSI	LEFT AND RIGHT
EXTEND	1500 PSI	
RETRACT	3000 PSI	
LEVEL SYSTEM	PSI	3000 MASTER AND SLAVE 1500
JIB	PSI	JIB UP 3000 - JIB DOWN 1000
AXLE LOCK	3000 PSI	
PLATFORM ROTATE	1000 PSI	(MAY DEVIATE TO PREVENT CHATTER)

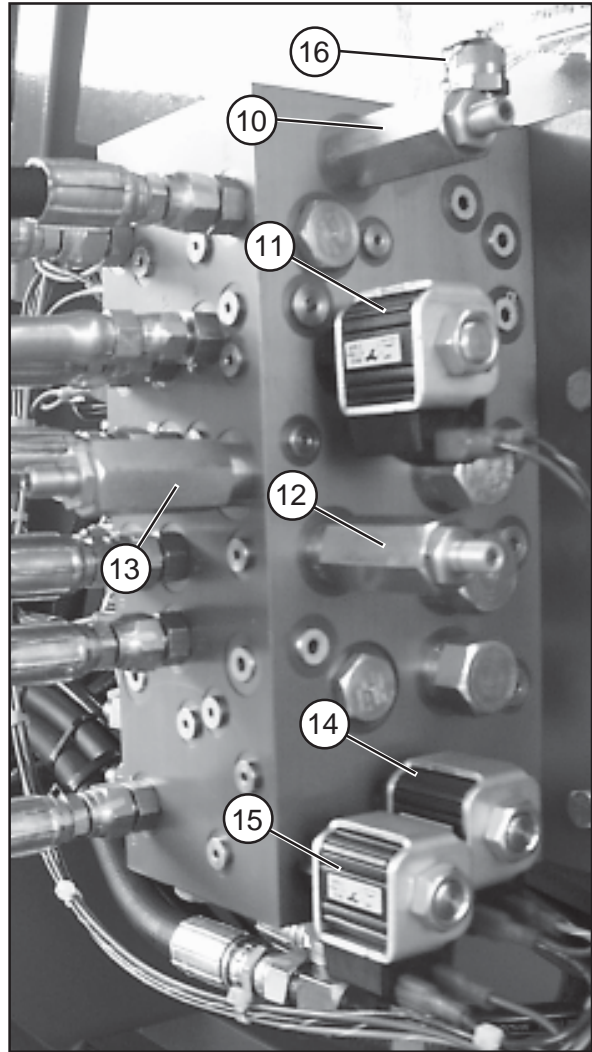
##### RELIEF VALVES;

MAIN PRESSURE	2700 PSI	
STEER CROSSOVERS	2700 PSI	BOTH DIRECTIONS
BOOM LOWERING	1450 PSI	
SWING SYSTEM	1000 PSI	
EXTEND, HIGH ANGLE	2200 PSI	
EXTEND, LOW ANGLE	1750 PSI	
JIB LOWER	1400 PSI	
PLATFORM ROTATOR	2000 PSI	BOTH DIRECTIONS



**Figure 3-16: Valve Manifold**

- 1. Steer Left Relief
- 2. Steering
- 3. Cage Level
- 4. Swing (Turret)
- 5. Lift Boom
- 6. Boom Extend
- 7. High Pressure Extend Relief
- 8. Low Pressure Extend Relief
- 9. Main Relief



**Figure 3-17: Valve Manifold**

- 10. Steer Right Relief
- 11. High Pressure Extend
- 12. Boom Lift Relief
- 13. Swing Relief
- 14. Dump
- 15. Boom Power
- 16. Pressure Test Port



## 3.12 Master Cylinder

### REMOVAL

1. Raise elevating assembly until master cylinder pins are accessible.
2. Support the cage assembly (refer to Figure 3-1).
3. Remove rod end retaining.
4. Mark and disconnect hoses and immediately cap the openings to prevent contamination.
5. Using a metal drift, remove rod end pin.
6. Remove base end pin retaining bolt and pin.
7. Carefully remove master cylinder.

### DISASSEMBLY

**Note: Provide a clean work area for this operation, and observe clean assembly practices. Seals and hydraulic cylinder components are highly sensitive to contamination that may not be visible to the naked eye.**

1. Unscrew head from cylinder.
2. Carefully pull rod assembly from cylinder.
3. Clamp rod end in vise and remove locknut and piston.
4. Slide the head off of the rod.
5. Remove seal kit components (wipers, rod seals, o-rings and backup rings) from head and piston.
6. Thoroughly clean all parts with solvent. Rinse the inside of the tube and allow to drain. A high pressure rinse and wipe with a lint free rag is preferable.
7. Inspect the rod, head, piston, and tube for scratches, pits, or polishing. Check seal grooves and sealing surfaces. Scratches or pits deep enough to catch the fingernail are unacceptable, replace the cylinder. Polishing is a sign of uneven loading. When this occurs, the surface should be checked for roundness. Cylinders not round within .007" should be replaced.

### ASSEMBLY

**NOTE: Torque all hardware to torques listed on page 3-29 unless otherwise specified.**

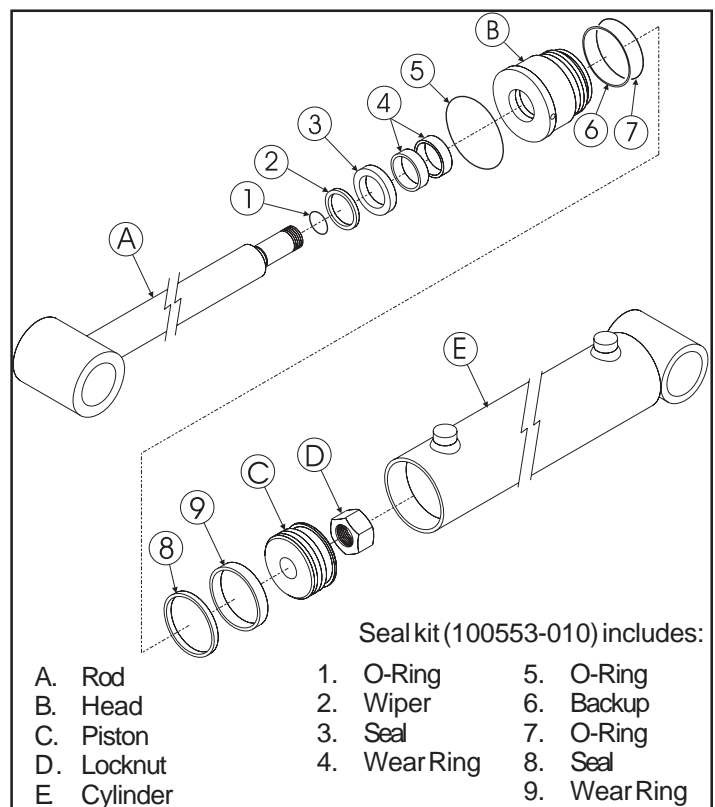
1. Lubricate all components and seals with clean hydraulic oil prior to assembly.

**Note: To avoid cutting the seals, do not use sharp edged tools during seal replacement. After installing seals allow at least one hour for the seals to elastically restore to their original shape before assembling cylinder.**

2. Install new seal kit to piston and head.
3. Lubricate rod wiper and seal with hydraulic oil and slide head onto rod.
4. Install piston and locknut (torque locknut to 375 - 450 ft/lbs) onto rod.
5. Lubricate seals on piston and head with hydraulic oil.
6. Carefully slide rod assembly into cylinder.
7. Thread head into cylinder.

### INSTALLATION

1. Follow steps from "REMOVAL" section in reverse order to install cylinder.
2. Remove boom support.
3. Slowly raise and lower boom several times. Check hydraulic connections for leaks. Check for proper slave cylinder operation.



**Figure 3-18: Master Cylinder**

### 3.13 Slave Cylinder

#### REMOVAL

1. Extend boom until slave cylinder base end pin is accessible. Support the cage assembly.
2. Remove rod end pin retaining bolt.
3. Mark and disconnect hoses and immediately cap the openings to prevent contamination.
4. Using a metal drift, remove rod end pin.
5. Remove base end pin retaining bolt and remove pin.
6. Carefully remove slave cylinder.

#### DISASSEMBLY

**Note: Provide a clean work area for this operation and observe clean assembly practices. Seals and hydraulic cylinder components are highly sensitive to contamination that may not be visible to the naked eye.**

1. Unscrew head from cylinder.
2. Carefully pull rod assembly from cylinder.
3. Clamp rod end in vise and turn off locknut.
4. Slide the head off of the rod.
5. Remove seal kit components (wipers, rod seals, o-rings and backup rings) from head, piston and seal block.
6. Thoroughly clean all parts with solvent. Rinse the inside of the tube and allow to drain. A high pressure rinse and wipe with a lint free rag is preferable.
7. Inspect parts for scratches, pits, or polishing. Check seal grooves and sealing surfaces. Scratches or pits deep enough to catch the fingernail are unacceptable; replace the cylinder. Polishing is a sign of uneven loading. When this occurs, the surface should be checked for roundness. Cylinders not round within .007" should be replaced.

#### ASSEMBLY

**NOTE: Torque all hardware to torques listed on page 3-29 unless otherwise specified.**

1. Lubricate all components and seals with clean hydraulic oil prior to assembly.

**Note: To avoid cutting the seals, do not use sharp edged tools during seal replacement. After installing seals allow at least one hour for the seals to elastically restore to their original shape before assembling cylinder.**

2. Install new seal kit items to piston and head.
3. Lubricate rod wiper and seal with hydraulic oil and slide head onto rod.
4. Install piston and locknut onto rod.
5. Lubricate seals on piston and head with hydraulic oil.
6. Carefully slide rod assembly into cylinder.
7. Thread head into cylinder.
8. Clean set screw in loctite primer. Install set screw using loctite #242.

#### INSTALLATION

1. Follow steps from "REMOVAL" section in reverse order to install cylinder.
2. Remove boom support.
3. Slowly raise and lower boom several times. Check hydraulic connections for leaks. Check for proper slave cylinder operation.

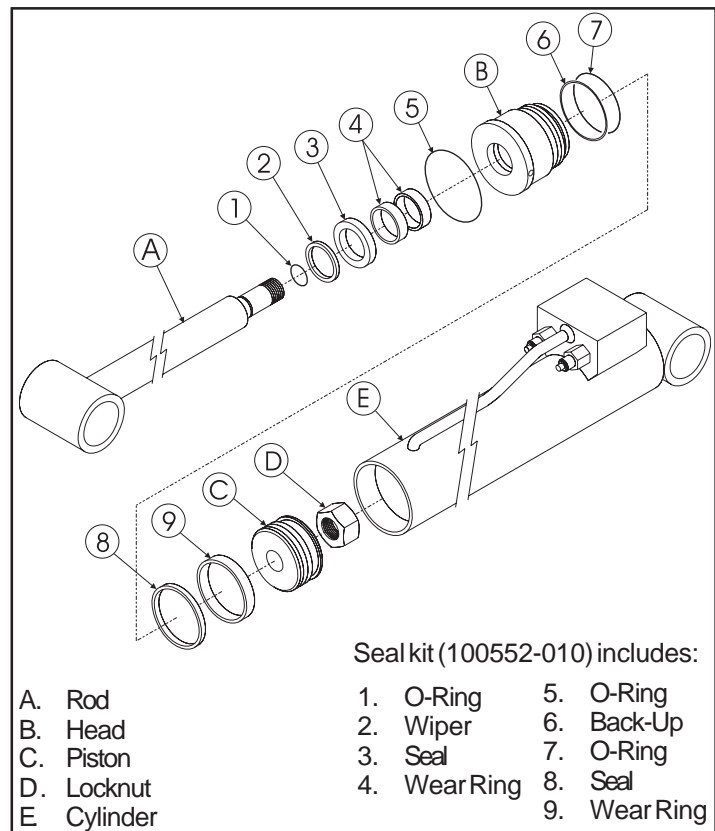


Figure 3-19: Slave Cylinder

## 3.14 Axle Lock Cylinder

### Removal

**Note:** Boom should be in fully lowered position before performing this operation.

1. Mark and disconnect hoses and immediately cap the openings to prevent contamination.
2. Remove hardware which secures axle lock cylinder. Remove cylinder.

### DISASSEMBLY

**Note:** Provide a clean work area for this operation, and observe clean assembly practices. Seals and hydraulic cylinder components are highly sensitive to contamination that may not be visible to the naked eye.

1. Unscrew head from cylinder
2. Carefully pull shaft assembly from cylinder.
3. Secure rod end and turn locknut off of rod.
4. Remove piston and slide the head off of the rod.
5. Remove seal kit components (wipers, rod seals, o-rings and backup rings) from head and piston.
6. Thoroughly clean all parts with solvent. Rinse the inside of the tube and allow to drain. A high pressure rinse and wipe with a lint free rag is preferable.
7. Inspect cylinder parts for scratches, pits, or polishing. Check seal grooves and sealing surfaces. Scratches or pits deep enough to catch the fingernail are unacceptable, replace the cylinder. Polishing is a sign of uneven loading. When this occurs, the surface should be checked for roundness. Cylinders not round within .007" should be replaced.

### ASSEMBLY

**NOTE:** Torque all hardware to torques listed on page 3-29 unless otherwise specified.

1. Lubricate all components and seals with clean hydraulic oil prior to assembly.

**Note:** To avoid cutting the seals, do not use sharp edged tools during seal replacement. After installing seals allow at least one hour for the seals to elastically restore to their original shape before assembling cylinder.

2. Install new seal kit items to piston and head.
3. Lubricate rod wiper and seal with hydraulic oil and slide head onto rod.

4. Install piston and locknut (torque locknut to 175-200 ft/lbs) onto rod.
5. Lubricate seals on piston and head with hydraulic oil.
6. Carefully slide rod assembly into cylinder.
7. Thread head into cylinder.

### INSTALLATION

1. Follow steps from "REMOVAL" section in reverse order to install cylinder.
2. Slowly cycle cage rotate cylinder several times. Check hydraulic connections for leaks. Check for proper cylinder operation.

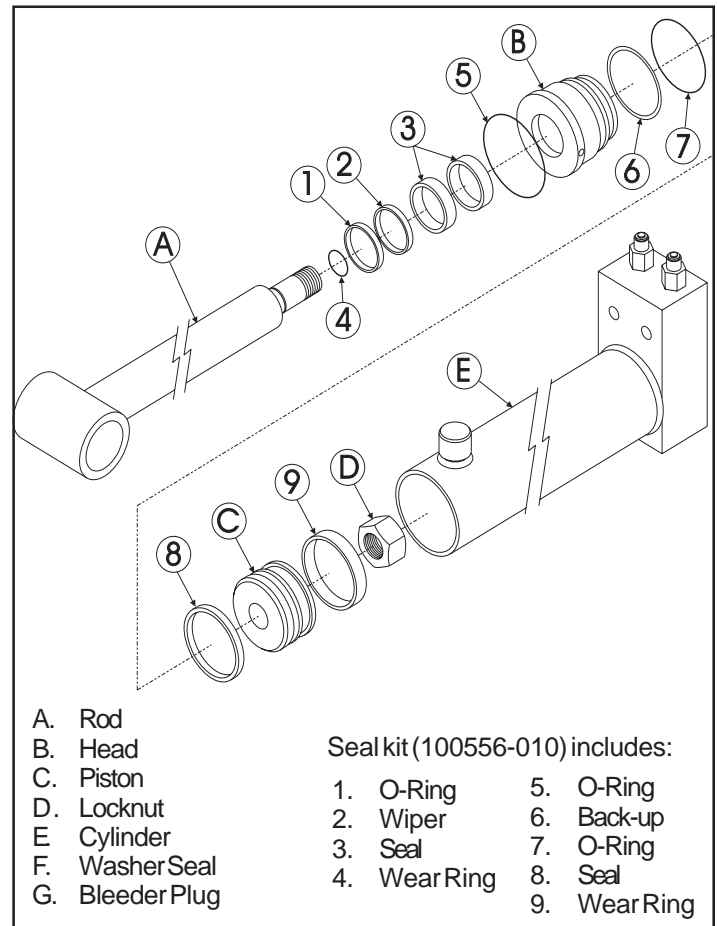


Figure 3-20: Axle Lock Cylinder

### 3.15 Steering Cylinder

#### REMOVAL

1. Mark and disconnect hoses and immediately cap the openings to prevent contamination.
2. Remove hardware which secures steering arms to rod ends.
3. Remove hardware which secures steering cylinder to the chassis. Remove steering cylinder.

#### DISASSEMBLY

**Note: Provide a clean work area for this operation, and observe clean assembly practices. Seals and hydraulic cylinder components are highly sensitive to contamination that may not be visible to the naked eye.**

1. Mark heads for position on cylinder. Unscrew heads from cylinder.

**IMPORTANT: Heads must be installed onto same end of cylinder as they were removed from.**

2. Carefully pull rod assembly from cylinder.
3. Remove seal kit components (wipers, rod seals, o-rings and backup rings) from heads and piston.
4. Thoroughly clean all parts with solvent. Rinse the inside of the tube and allow to drain. A high pressure rinse and wipe with a lint free rag is preferable.
5. Inspect cylinder parts for scratches, pits, or polishing. Check seal grooves and sealing surfaces. Scratches or pits deep enough to catch the fingernail are unacceptable, replace the cylinder. Polishing is a sign of uneven loading. When this occurs, the surface should be checked for roundness. Cylinders not round within .007" should be replaced.

#### ASSEMBLY

**NOTE: Torque all hardware to torques listed on page 3-29 unless otherwise specified.**

1. Lubricate all components and seals with clean hydraulic oil prior to assembly.

**Note: To avoid cutting the seals, do not use sharp edged tools during seal replacement. After installing seals allow at least one hour for the seals to elastically restore to their original shape before assembling cylinder.**

2. Install new seal kit items to piston and heads.
3. Lubricate seals on piston.
4. Carefully slide rod assembly into cylinder.
5. Thread heads into cylinder.

**IMPORTANT: Heads must be installed onto same end of cylinder as they were removed from.**

#### INSTALLATION

1. Follow steps from "REMOVAL" section in reverse order to install cylinder.
2. Slowly steering cylinder several times. Check hydraulic connections for leaks. Check for proper cylinder operation.

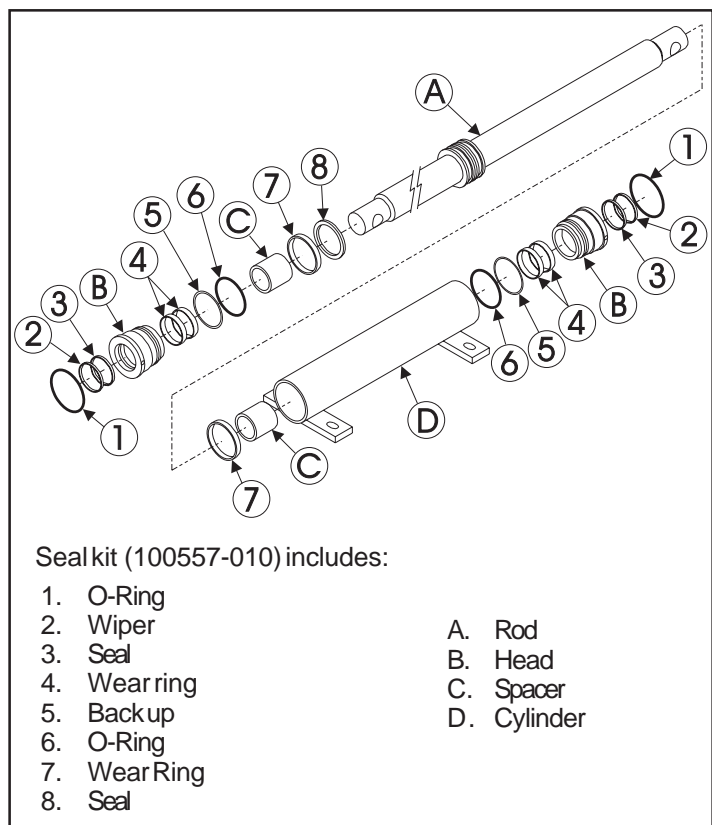


Figure 3-21: Steering Cylinder

## 3.16 Jib Cylinder

### REMOVAL

1. Using an overhead hoist or crane, support the cage assembly at a convenient working height.
2. Mark and disconnect hoses and immediately cap the openings to prevent contamination.
3. Remove hardware which secures jib cylinder pins.

**NOTE: Jib cylinder is heavy. Take appropriate measures to support cylinder.**

4. Remove jib cylinder pins. Remove jib cylinder.

### DISASSEMBLY

**Note: Provide a clean work area for this operation, and observe clean assembly practices. Seals and hydraulic cylinder components are highly sensitive to contamination that may not even be visible to the naked eye.**

1. Remove counterbalance valves from cylinder.
2. Unscrew head from cylinder.
3. Carefully pull shaft assembly from cylinder.
4. Secure rod end and locknut off of rod.
5. Slide the piston and head off of the rod.
6. Remove seal kit components (wipers, rod seals, o-rings and backup rings) from head and piston.
7. Thoroughly clean all parts with solvent. Rinse the inside of the tube and allow to drain. A high pressure rinse and wipe with a lint free rag is preferable.
7. Inspect cylinder parts for scratches, pits, or polishing. Check seal grooves and sealing surfaces. Scratches or pits deep enough to catch the fingernail are unacceptable, replace the cylinder. Polishing is a sign of uneven loading. When this occurs, the surface should be checked for roundness. Cylinders not round within .007" should be replaced.

### ASSEMBLY

**NOTE: Torque all hardware to torques listed on page 3-29 unless otherwise specified.**

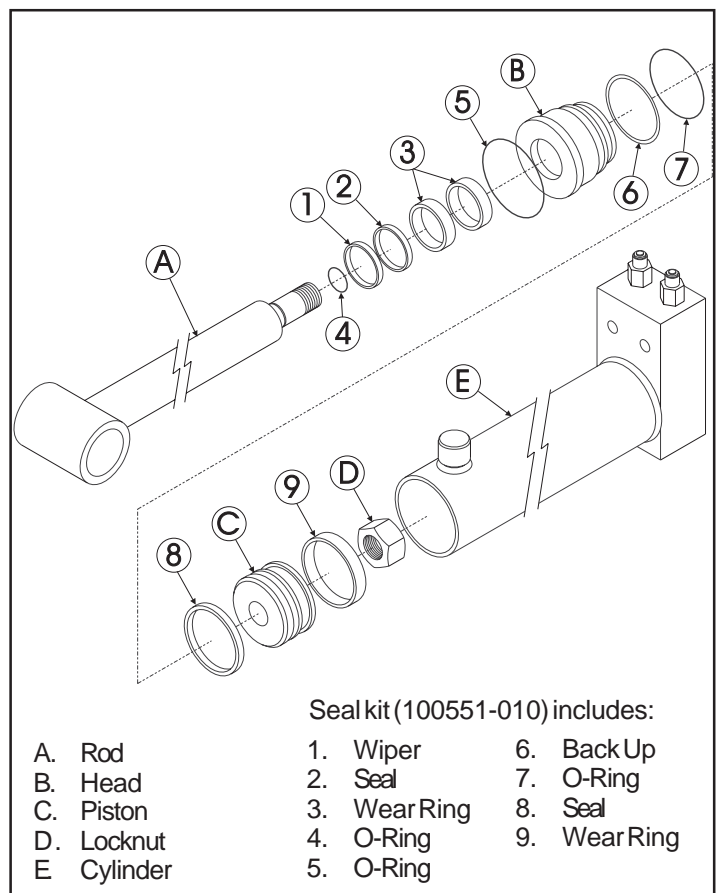
1. Lubricate all components and seals with clean hydraulic oil prior to assembly.

**Note: To avoid cutting the seals, do not use sharp edged tools during seal replacement. After installing seals allow at least one hour for the seals to elastically restore to their original shape before assembling cylinder.**

2. Install new seal kit items to piston and head.
3. Lubricate rod wiper and seal with hydraulic oil and slide head onto rod.
4. Install piston and locknut (torque locknut to 375-450 ft/lbs) onto rod.
5. Lubricate seals on piston and head with hydraulic oil.
6. Carefully slide rod assembly into cylinder.
7. Thread head into cylinder.

### INSTALLATION

1. Follow steps from "REMOVAL" section in reverse order to install cylinder.
2. Slowly cycle jib cylinder several times. Check hydraulic connections for leaks. Check for proper cylinder operation.



**Figure 3-22: Jib Cylinder**

### 3.17 Lift Cylinder

#### REMOVAL

1. Raise elevating assembly until cylinder pins are accessible.
1. Support the elevating assembly (refer to Figure 3-1).
2. Mark and disconnect hoses and immediately cap the openings to prevent contamination.
3. Remove hardware which secures cylinder. Remove cylinder.

#### DISASSEMBLY

**Note: Provide a clean work area for this operation, and observe clean assembly practices. Seals and hydraulic cylinder components are highly sensitive to contamination that may not be visible to the naked eye.**

1. Unscrew head from cylinder
2. Carefully pull shaft assembly from cylinder.
3. Secure end of rod and turn locknut off of rod.
4. Slide piston and head off of the rod.
5. Remove seal kit components (wipers, rod seals, o-rings and backup rings) from head and piston.
6. Thoroughly clean all parts with solvent. Rinse the inside of the tube and allow to drain. A high pressure rinse and wipe with a lint free rag is preferable.
7. Inspect cylinder parts for scratches, pits, or polishing. Check seal grooves and sealing surfaces. Scratches or pits deep enough to catch the fingernail are unacceptable, replace the cylinder. Polishing is a sign of uneven loading. When this occurs, the surface should be checked for roundness. Cylinders not round within .007" should be replaced.

#### ASSEMBLY

**NOTE: Torque all hardware to torques listed on page 3-29 unless otherwise specified.**

1. Lubricate all components and seals with clean hydraulic oil prior to assembly.

**Note: To avoid cutting the seals, do not use sharp edged tools during seal replacement. After installing seals allow at least one hour for the seals to elastically restore to their original shape before assembling cylinder.**

2. Install new seal kit items to piston and head.
3. Lubricate rod wiper and seal with hydraulic oil and slide head onto rod.
4. Slide piston onto rod.

5. Install locknut (torque locknut to 1900-2400 ft/lbs) onto rod.
6. Lubricate seals on piston and head with hydraulic oil.
7. Carefully slide rod assembly into cylinder.
8. Thread head into cylinder.

#### INSTALLATION

1. Follow steps from "REMOVAL" section in reverse order to install cylinder.
2. Slowly cycle cylinder several times. Check hydraulic connections for leaks. Check for proper cylinder operation.

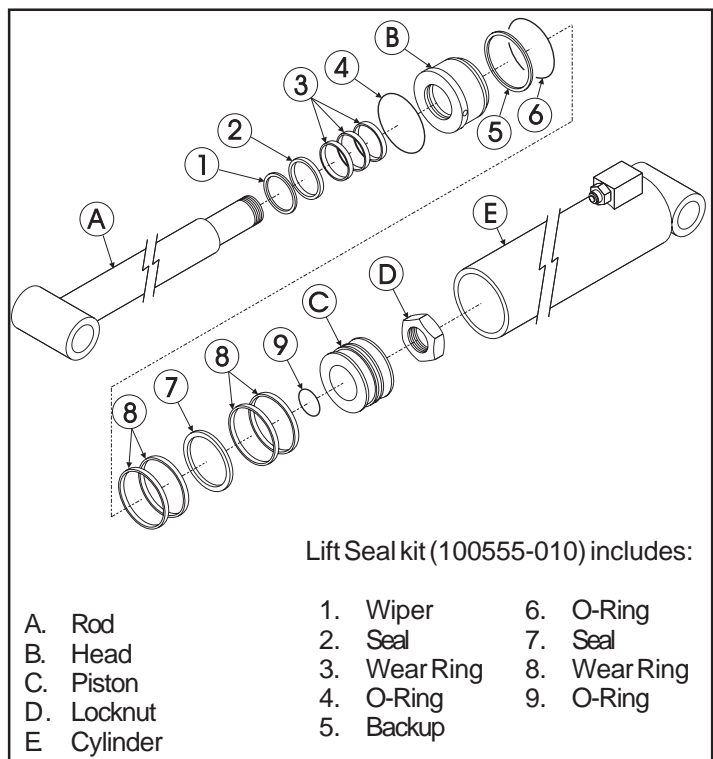


Figure 3-23: Lift Cylinder

## 3.18 Boom Extend Cylinder

### DISASSEMBLY

**Note:** Provide a clean work area for this operation, and observe clean assembly practices. Seals and hydraulic cylinder components are highly sensitive to contamination that may not be visible to the naked eye.

1. Remove set screw and unscrew head from cylinder.
3. Carefully pull shaft assembly from cylinder.
4. Secure rod end and turn locknut off of shaft.
5. Slide the head off of the rod.
6. Remove seal kit components (wipers, rod seals, o-rings and backup rings) from head and piston.
7. Thoroughly clean all parts with solvent. Rinse the inside of the tube and allow to drain. A high pressure rinse and wipe with a lint free rag is preferable.
8. Inspect cylinder parts for scratches, pits, or polishing. Check seal grooves and sealing surfaces. Scratches or pits deep enough to catch the fingernail are unacceptable, replace the cylinder. Polishing is a sign of uneven loading. When this occurs, the surface should be checked for roundness. Cylinders not round within .007" should be replaced.

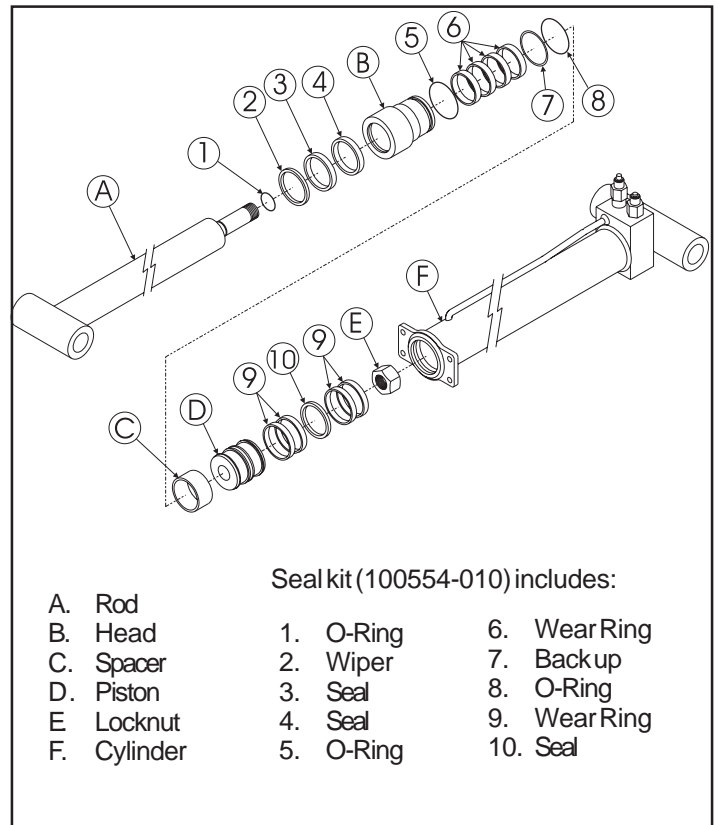
### ASSEMBLY

**NOTE:** Torque all hardware to torques listed on page 3-29 unless otherwise specified.

1. Lubricate all components and seals with clean hydraulic oil prior to assembly.

**Note:** To avoid cutting the seals, do not use sharp edged tools during seal replacement. After installing seals allow at least one hour for the seals to elastically restore to their original shape before assembling cylinder.

2. Install new seal kit items to piston and head.
3. Lubricate rod wiper and seal with hydraulic oil and slide head onto rod.
4. Install locknut onto rod (torque locknut to 525-640 ft/lbs).
5. Lubricate seals on piston and head with hydraulic oil.
6. Carefully slide rod assembly into cylinder.
7. Thread head into cylinder.



**Figure 3-24: Boom Extend Cylinder**

## 3.19 Rotary Actuator

### Theory of Operation

The HP-9K Series rotary actuator is a simple mechanism that uses the sliding spline operating concept to convert linear piston motion into powerful shaft rotation. Each actuator is composed of a housing (01) and only two moving parts: the central shaft with integrated bearing tube and mounting flange (02), and the annular piston sleeve (03). Helical spline teeth machined on the shaft engage matching splines on the inside diameter of the piston. The outside diameter of the piston carries a second set of splines, of opposite hand, which engage with matching splines in the housing. As hydraulic pressure is applied, the piston is displaced axially within the housing - similar to the operation of a hydraulic cylinder - while the splines cause the shaft to rotate. When the control valve is closed, oil is trapped inside the actuator, preventing piston movement and locking the shaft in position.

The shaft is supported radially by the large upper radial bearing (302) and the lower radial bearing (303). Axially, the shaft is separated from the housing by the upper and lower thrust rings (304). The end cap (04) is adjusted for axial clearance and locked in position by set screws (105).

Displacement and torque are identical for clockwise and counter-clockwise rotation.

### Disassembly and Inspection

Place on a clean workbench with ample room for all internal parts as they are removed. Remove all hydraulic fittings. Loosen set screws (105) and unthread end cap (04). Use a small grinder to remove the set screw thread stakes if necessary. Remove the stop tube (400), if furnished. The shaft is now free to move up and out of engagement with the piston sleeve (03). Note the timing marks on the spline teeth - small punch marks on the face of each gear. See Figure 3-27. Correct orientation of the marks will greatly simplify actuator timing upon reassembly. *Do not remove any component without first locating the timing marks.*

After removing the shaft, the piston sleeve (03) can now be moved down and out of the housing. Remove all seals and bearings from their grooves. Clean all parts thoroughly and inspect for wear. A small amount of wear in the spline teeth will have little effect on the actuator strength. New spline sets are manufactured with a backlash of about .005" per mating set. After long service, a backlash of about .015" per set may still be acceptable in most cases, depending on the required accuracy of the application.

Check the housing ring gear for wear. Inspect the cylinder bore for wear and scratches. The surface finish should be 32 RMS or better; rehone if necessary. The wear rings (302)(303) should have a maximum radial clearance of .006". A clearance in excess of .008" requires replacement. Rough and grooved shaft journals require shaft replacement.

### Assembly and Testing

Wash all parts thoroughly in cleaning solvent and blow dry. Coat all sealing and working surfaces with a good grade hydraulic oil. Install seals and bearings in the piston sleeve, shaft, and end cap oriented as seen in Figure 3-25. The gap on the wear rings (302) (303) should not exceed .125". Place the actuator in a vertical position and install the piston sleeve (03) in timed relation to the housing. Apply firm pressure as the new seals enter the housing and become compressed by the housing chamber. **CAUTION:** Take care to insure the piston sleeve does not mar the cylinder bore. The timing marks must be aligned for proper shaft orientation, see Figure 3-27.

The shaft (02) is installed by again aligning the proper punched timing marks, see Figure 3-27. Use masking tape to temporarily tape the threaded portion of the shaft to help clear the piston seal (200). Turn the actuator upside-down and install the stop tube (400), if furnished.

Apply antiseize to threaded and surrounding areas of the end cap (04) and thread onto the shaft. Torque the end cap to 60 ft/lb.

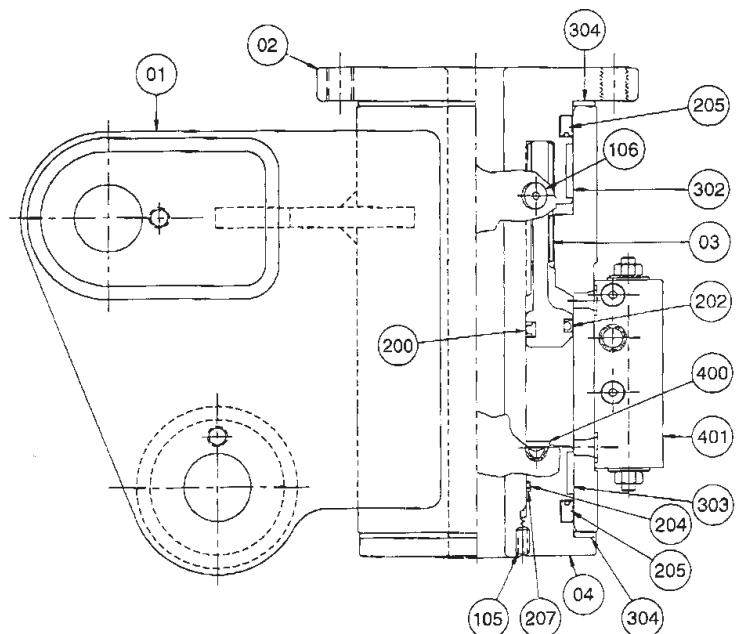


Figure 3-25



Test the actuator for proper operation and leakage prior to securing the endcap with set screws. Mark the relative position of endcap and housing and check the marks periodically during the tests below to ensure that the endcap does not back out. Apply pressure to the actuator ports and check breakaway. The breakaway should be about 200 PSI. Alternately apply pressure to port on the opposite side of the piston and check for axial movement. The axial movement should not exceed .020". If the axial movement is excessive re-tighten the end cap. Apply 3000 PSI pressure to one port until piston bottoms out and the actuator rotation stops. Remove non-pressurized hydraulic line and check for internal and external leakage. Repeat leakage test on opposite actuator port.

Install set screws (105) and stake to insure they will not back out during actuator operation.

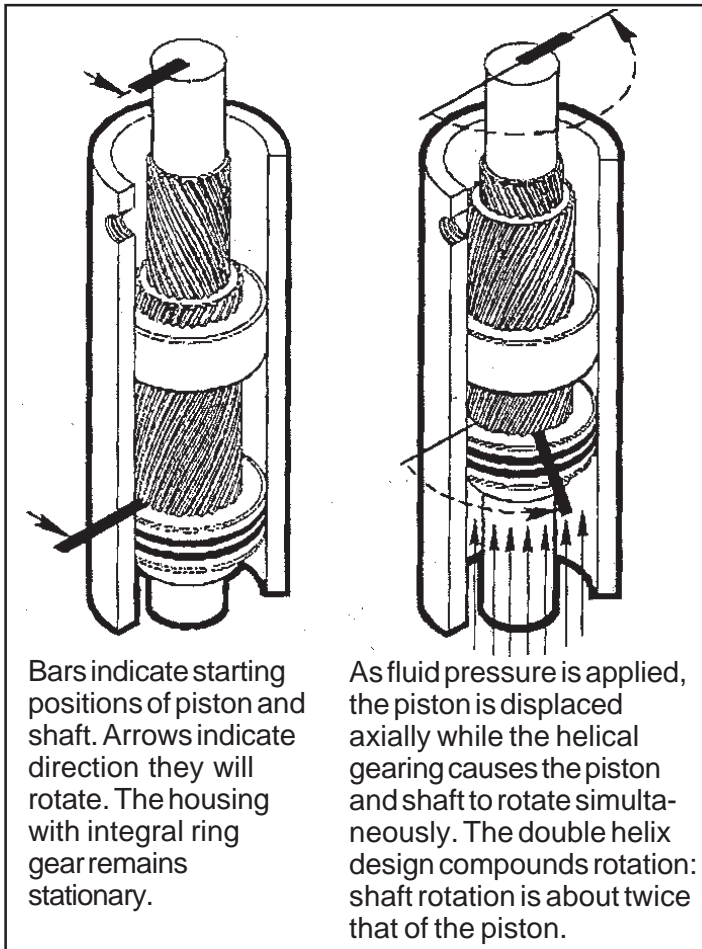


Figure 3-26

## Hydraulic Line Attachment

The hydraulic lines from the control valve to the actuator should be as short as possible. If the lines hold more oil than the actuator displaces, the oil is cycled back and forth, and not allowed to flow to tank for filtering and cooling, resulting in accelerated actuator wear.

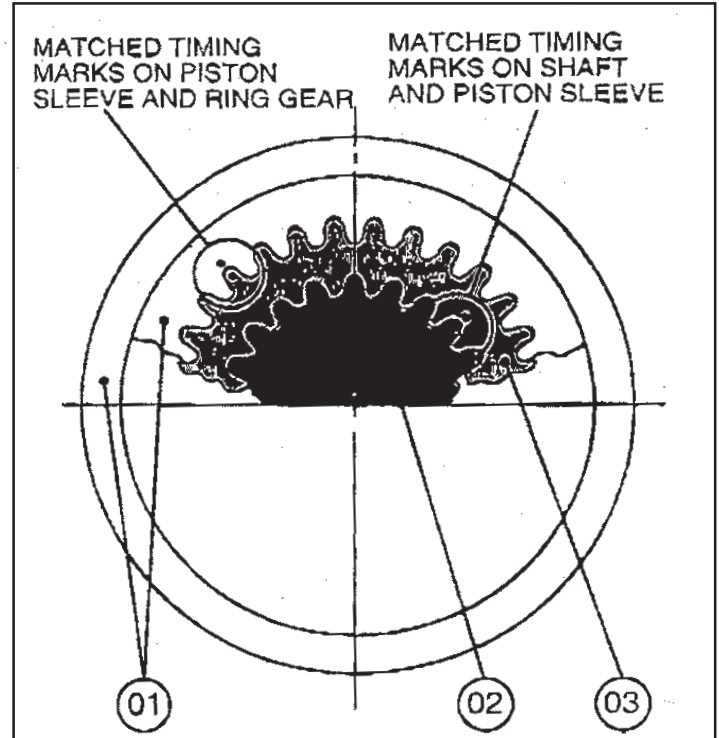


Figure 3-27

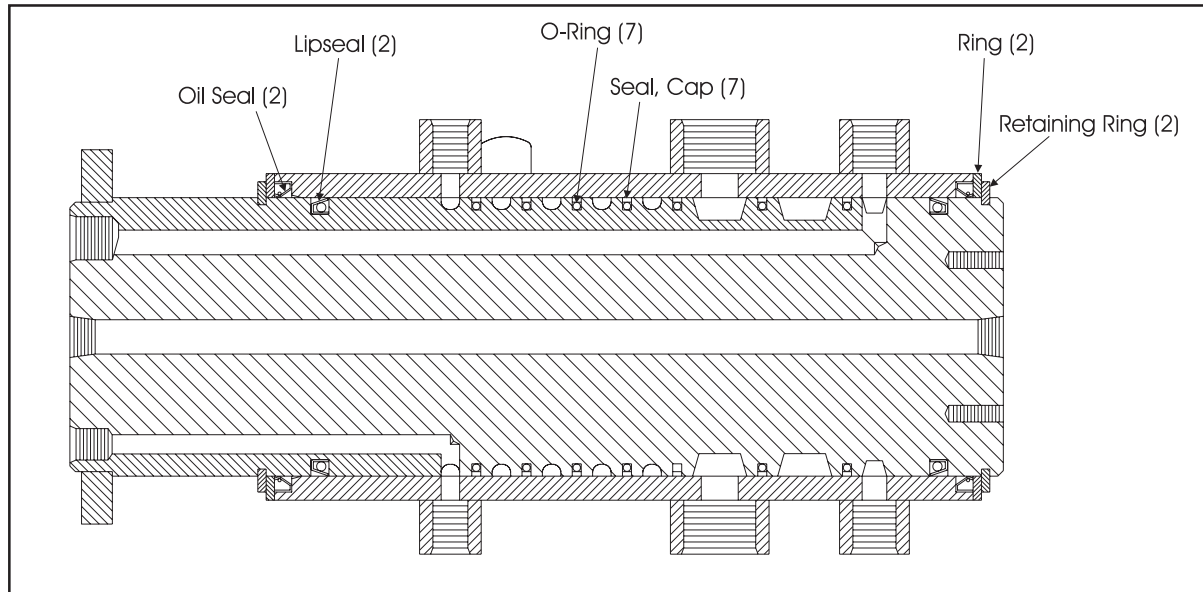


Figure 3-28: Rotary Manifold

### 3.20 ROTARY MANIFOLD REMOVAL

1. Mark and tag all hoses.
2. Remove all hoses from Rotary Manifold.
3. Remove Rotary Manifold from machine.

**Note:** Provide a clean work area for this operation, and observe clean assembly practices. Seals and O-Rings are highly sensitive to contamination that may not be visible to the naked eye.

### DISASSEMBLY

1. Remove Retaining Rings from each end of Rotary Manifold.
2. Carefully slide body out of housing.
3. Remove seal kit components (O-Rings, Seals, and Retaining Rings).
4. Thoroughly clean all parts with solvent. Rinse the inside of the tube and allow to drain. A high pressure rinse and wipe with a lint free rag is preferable.
5. Inspect the body and housing for scratches, pits, or polishing. Check seal grooves and sealing surfaces. Scratches or pits deep enough to catch the fingernail are unacceptable, replace the manifold.

### ASSEMBLY

**Note:** Torque all hardware and fittings to torques listed on page 3-29 unless otherwise specified.

1. Lubricate all seals with clean hydraulic oil prior to assembly.
2. Install new seals on body and housing.
3. Carefully slide body into housing.
4. Reinstall Rings and Retaining Rings.

### INSTALLATION

1. Installation is reverse of removal.
2. Replenish hydraulic fluid in tank.
3. Run hydraulic system for several minutes to remove air from hydraulic lines. Cycle cylinders for each boom function.
4. Rotate turret completely.
5. Check Rotary Manifold for leaks. Check that all boom functions are operating properly.

## 3.21 LONG TERM STORAGE

If the work platform is to be placed in long term storage (dead storage) follow these recommended preservation procedures.

### PRESERVATION

1. Clean painted surfaces. If paint is damaged, repaint.
2. Fill the hydraulic tank to operating level. Fluid will be visible at the sight gauge.

**IMPORTANT: Do not fill the hydraulic tank while the platform is elevated.**

**NOTE: Do not drain the hydraulic system prior to long term storage.**

3. Coat exposed portions of cylinder rods with a preservative such as multipurpose grease and wrap with a barrier material.
4. Coat all exposed unpainted metal surfaces with preservative.
5. Service the engine according to the manufacturers recommendations.
6. Remove the battery and place in alternative service.

## 3.22 Torque Specifications (Tables 3-3 & 3-4)

### FASTENERS

Use the following values to torque fasteners used on UpRight Work Platforms unless a specific torque value is called out for the part being installed.

**Table 3-3: Bolt Torque**

THREAD SIZE <small>American National Std.-UNC (course) Grade 5</small>	WIDTH ACROSS FLATS	TORQUE VALUE	
		ENGLISH	METRIC
1/4	7/16	110 In/Lbs	12 N·m
5/16	1/2	190 In/Lbs	22 N·m
3/8	9/16	30 Ft/Lbs	41 N·m
7/16	5/8	50 Ft/Lbs	68 N·m
1/2	3/4	75 Ft/Lbs	102 N·m
5/8	1 5/16	150 Ft/Lbs	203 N·m
3/4	1 1/8	250 Ft/Lbs	339 N·m
7/8	1 15/16	400 Ft/Lbs	542 N·m
1	1 1/2	600 Ft/Lbs	813 N·m

### HYDRAULIC COMPONENTS

Use the following values to torque hydraulic components used on UpRight Work Platforms.

**Note: Always lubricate threads with clean hydraulic oil prior to installation.**

**Table 3-4: Hydraulic Component Torque**

TYPE: SAEPART SERIES	CARTRIDGE POPPET		FITTINGS		HOSES	
	(Ft/Lbs)	(Nm)	(Ft/Lbs)	(Nm)	(In/Lbs)	(Nm)
#4	N/A	N/A	N/A	N/A	135-145	15-16
#6	N/A	N/A	10-20	14-27	215-245	24-28
#8	25-30	34-41	25-30	34-41	430-470	49-53
#10	35-40	47-54	35-40	47-54	680-750	77-85
#12	85-90	115-122	85-90	115-122	950-1050	107-131
#16	130-140	176-190	130-140	176-190	1300-1368	147-155

Coil nuts: 30 IN/Lbs (3 Nm)

NOTES:

## 4.0 Introduction

The following section on troubleshooting provides guidelines on the types of problems users may encounter in the field, helps determine the cause of problems, and suggests proper corrective action.

Careful inspection and accurate analysis of the symptoms listed in the Troubleshooting Guide will localize the trouble more quickly than any other method. This manual cannot cover all possible problems that may occur. If a specific problem is not covered in this manual, call our toll free number for service assistance.

Referring to *Section 2.0* and *5.0* will aid in understanding the operation and function of the various components and systems of the SB60 and help in diagnosing and repair of the machine.

### GENERAL PROCEDURE

Use the charts on the following pages to help determine the cause of a fault in your UpRight SB60.

1. Verify your problem.  
Do a full function test from both platform controls and chassis controls and note all functions that are not operating correctly.
2. Narrow the possible causes of the malfunction.  
Use the troubleshooting guide to determine which components are common to all circuits that are not functioning correctly.
3. Identify the problem component.  
Test components that are common to all circuits that are not functioning correctly. Remember to check wires and terminals between suspect components. Be sure to check connections to battery negative.
4. Repair or replace component found to be faulty.
5. Verify that repair is complete.  
Do a full function test from both platform and chassis controls to verify that all functions are operating correctly and machine is performing to specified values.

**NOTE: Spike protection diodes at components have been left out of the charts to eliminate confusion.**



### WARNING



When troubleshooting, ensure that the work platform is resting on a firm, level surface.  
When performing any service which requires the platform to be raised, the Elevating Assembly must be blocked.  
Disconnect the battery ground cable when replacing or testing the continuity of any electrical component.

FOR SERVICE ASSISTANCE, IN THE U.S.A., CALL:

**1-800-926-5438**

FROM OUTSIDE THE USA, CALL 1-559-896-5150

## THEORY OF OPERATION

The operating functions of the SB60 are powered by two hydraulic pumps.

The large Rexroth pump powers the drive wheels and the smaller Barnes pump powers all the other functions.

Driving, Lift, Turret and Boom Extend operations are controlled from a SuperFlex controller located in the platform control box.

All other functions are operated by switches or levers located in the platform or Chassis control boxes.

There is an emergency power unit to provide power to lower the platform in case of engine failure.

## TROUBLESHOOTING

1. Verify your problem.

Do a full function test from platform controls and chassis controls and note all functions that are not operating correctly.

2. Narrow the possible causes of the malfunction.

Determine which components are common to all circuits that are not functioning correctly.

3. Identify the problem component.

Test components that are common to all circuits that are not functioning correctly. Remember to check wires and terminals between suspect components. Be sure to check connections to battery negative.

4. Repair or replace component found to be faulty.

5. Verify that repair is complete.

Do a full function test from platform and chassis controls to verify that all functions are operating correctly and machine is performing to specified values.

## SPECIAL TOOLS

Following is a list of tools which may be required to perform certain maintenance procedures on the SB60.

Flow Meter with Pressure Gauge (UpRight P/N 067040-000)

0-1000 PSI Hydraulic Pressure Gauge with Adapter Fittings (UpRight P/N 014124-010)

0-3000 PSI Hydraulic Pressure Gauge with Adapter Fittings (UpRight P/N 014124-030)

Adapter Fitting (UpRight P/N 063965-002)

Inclinometer (UpRight P/N 010119-000)

SuperFlex Optimizer (UpRight P/N 100329-000)

Crimping Tool (UpRight P/N 028800-009)

Terminal Removal Tool (UpRight P/N 028800-006)

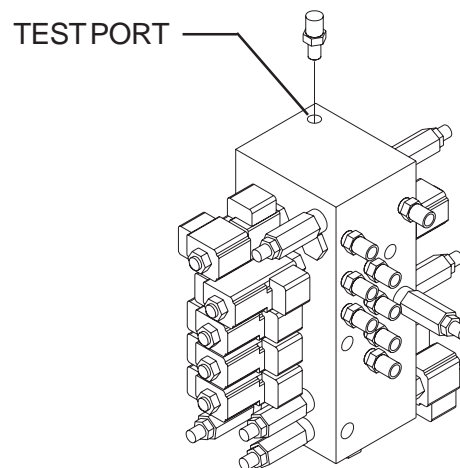
## ADJUSTMENT PROCEDURES

Hydraulic settings must be checked whenever a component is repaired or replaced.

Remove counter balance valves and "bench test" them if they are suspect.

Connect a pressure meter of appropriate range to the test port located on top of the hydraulic manifold.

Correct pressure settings are listed in the hydraulic schematic (UpRight Drawing #100027-000).



Refer to SuperFlex Optimizer settings listed in SuperFlex manual supplied with Optimizer.

## CHECKING PUMP PRESSURES

Remove hose from pumpport and connect pressure tester.

# Troubleshooting

Table 4-1 Trouble Shooting Guide - Hydraulic Schematic

COMPONENT	FUNCTION																	
	Engine Start and Run	Drive Forward	Drive Reverse	Second speed Drive	Steer Right	Steer Left	Axle Float	Brake Release	Boom Raise	Boom Lower	Boom Extend	Boom Retract	Jib Raise	Jib Lower	Platform Rotate	Turret Rotate	Cage Level	Emergency down
2 Speed Valve				X														
Auxillary Pump									X		X		X		X			X
Axle Lock PO Check		X	X	X														
Axle Lock Valve		X	X	X														
Boom Flow Divider .9GPM													X	X	X		X	
Boom Power Valve													X	X	X			
Boom Power LS CV								X	X	X	X	X	X	X	X	X	X	
Brake								X										
Brake Valve								X										
Bypass Valve								X										
Down Relief									X									
Drive Motor		X	X	X														
Dump Valve								X	X	X	X	X	X	X	X	X	X	X
Extend Cylinder										X	X							
Extend Hydrostat Valve										X	X							
Extend LS CV										X	X							
Extend Orifice 2 GPM										X								
Extend Overcenter Valve										X	X							
Extend Relief										X	X							
Extend Shuttle Valve										X	X							
Extend Valve										X	X							
Flow Divider For / Aft		X	X	X														
Flow Divider Side / Side		X	X	X														
Hydrostatic Pump		X	X	X			X											
Jib Cylinder													X	X				
Jib Overcenter Valves													X	X				
Jib Relief Down														X				
Jib Valve													X	X				
L S Bleed								X	X	X	X	X	X	X	X	X	X	
Level Valve																		X
Level Valve LS CV																		X
Lift Cylinder								X	X									
Lift Hydrostat Valve								X	X									
Lift LS CV								X	X									
Lift Orifice 3.5 GPM								X	X									
Lift Overcenter Valve									X									
Lift Shuttle Valve								X	X									
Lift Valve								X	X									
Main Relief								X	X	X	X	X	X	X	X	X	X	
Master Cylinder																		X
Master Cylinder Overcenter Valves																		X
Oscillating Axle Cylinder							X											
Platform Rotator																X		
Platform Rotator Flow Divider .2 GPM																X		
Platform Rotator Relief Valves																X		
Platform Rotator Valve																X		
Pump					X	X		X	X	X	X	X	X	X	X	X	X	
Retract Orifice 4.5 GPM												X						
Retract Relief												X						
Return Filter								X	X	X	X	X	X	X	X	X	X	X

# Troubleshooting

Table 4-1 Trouble Shooting Guide - Hydraulic Schematic (continued)

COMPONENT	FUNCTION																	
	Engine Start and Run	Drive Forward	Drive Reverse	Second speed Drive	Steer Right	Steer Left	Axle Float	Brake Release	Boom Raise	Boom Lower	Boom Extend	Boom Retract	Jib Raise	Jib Lower	Platform Rotate	Turret Rotate	Cage Level	Emergency down
Rotary Coupling		X	X		X	X	X	X										
Slave Cylinder																	X	
Slave Cylinder Overcenter Valves																	X	
Steer LS CV																	X	
Steer Orifice					X	X												
Steer PO Check Lt						X												
Steer PO Check Rt					X													
Steer Relief LT						X												
Steer Relief RT					X													
Steer Valve					X	X												
Steering Cylinder					X	X												
Suction Screen		X	X	X			X											
Suction Screen					X	X	X	X	X	X	X	X	X	X	X	X	X	
Swing Hydrostat Valve															X			
Swing LS CV															X			
Swing Motor															X			
Swing Orifice 3.5 GPM															X			
Swing Overcenter Valve															X			
Swing Relief															X			
Swing Shuttle Valve															X			
Swing Valve															X			
Battery	X																	
Battery Aux																		X
Charge Isolator																		X
Starter Motor	X																	
Alternator	X																	
LPG Shutoff	X																	
LPG Vacuum Switch	X																	
Fuel Pump	X																	
Distributor	X																	
Ignition Coil	X																	
Governor Controller	X																	
Throttle Actuator	X																	
Aux Pump																		X
Aux Pump Relay																		X
Level Sensor																		
Forward Proportional Valve		X		X														
Reverse Proportional Valve			X	X														
Water Temperature Gauge	X																	
Water Temperature Sending Unit	X																	
Oil Pressure Gauge	X																	
Oil Pressure Sending Unit	X																	
Hour Meter	X																	
Oil Pressure Switch	X																	
Aux Power Relay Coil																		X
Aux Power Relay Contacts																		X
Propane Relay Coil	X																	
Propane Relay Contacts	X																	
Gasoline Relay Coil	X																	



# Troubleshooting

Table 4-2 Trouble Shooting Guide - Electrical Schematic

FUNCTION COMPONENT	Engine Start and Run	Drive Forward	Drive Reverse	Second speed Drive	Steer Right	Steer Left	Axle Float	Brake Release	Boom Raise	Boom Lower	Boom Extend	Boom Retract	Jib Raise	Jib Lower	Platform Rotate	Turret Rotate	Cage Level	Emergency down
	Gasoline Relay Contacts	X																
Start Relay Coil	X																	
Start Relay Contacts	X																	
Ignition Relay Coil	X																	
Ignition Relay Contacts	X																	
Boom Power Relay Coil													X	X	X			
Boom Power Relay Contacts												X	X	X				
Boom Solenoid												X	X	X				
Brake / Hi Throttle Relay Coil		X	X															
Brake / Hi Throttle Relay Contacts		X	X					X										
Brake Solenoid		X	X					X										
Dump / Mid Throttle Relay Coil					X	X	X		X	X	X	X	X	X	X	X	X	X
Dump / Mid Throttle Relay Contacts					X	X	X		X	X	X	X	X	X	X	X	X	X
Dump Solenoid					X	X	X		X	X	X	X	X	X	X	X	X	X
Tilt Relay Coil		X	X						X	X	X	X	X	X	X	X	X	X
Tilt Relay Contacts		X	X						X	X	X	X	X	X	X	X	X	X
Aux Power Relay Coil																		X
Aux Power Relay Contacts																		X
Drive Interlock Switch Lift		X	X	X														
Drive Interlock Switch Extend		X	X	X														
Drive Interlock Switch Jib		X	X	X														
Shift Solenoid				X														
Shift Relay Coil				X														
Shift Relay Contacts				X														
Steer Right Solenoid					X													
Steer Right Relay Coil					X													
Steer Right Relay Contacts					X													
Steer Left Solenoid						X												
Steer Left Relay Coil						X												
Steer Left Relay Contacts						X												
Trim Up Solenoid																		X
Trim Up Relay Coil																		X
Trim Up Relay Contacts																		X
Trim Down Solenoid																		X
Trim Down Relay Coil																		X
Trim Down Relay Contacts																		X
Axle Lock Solenoid		X	X															
Axle Lock Relay Coil		X	X															
Axle Lock Relay Contacts		X	X															
Lift Cushion Upper Hg Switch									X									
Superflex Controller		X	X	X	X	X	X	X	X	X	X	X	X	X	X	X		
Jib Up Solenoid													X					
Jib Up Relay Coil													X					
Jib Up Relay Contacts													X					
Jib Down Solenoid														X				
Jib Down Relay Coil														X				
Jib Down Relay Contacts														X				
Jib Switch													X	X				
Platform Rotate Right Solenoid															X			
Platform Rotate Right Relay Coil															X			

# Troubleshooting

Table 4-2 Trouble Shooting Guide - Electrical Schematic (continued)

COMPONENT	FUNCTION																	
	Engine Start and Run	Drive Forward	Drive Reverse	Second speed Drive	Steer Right	Steer Left	Axle Float	Brake Release	Boom Raise	Boom Lower	Boom Extend	Boom Retract	Jib Raise	Jib Lower	Platform Rotate	Turret Rotate	Cage Level	Emergency down
Platform Rotate Right Relay Contacts															X			
Platform Rotate Left Solenoid															X			
Platform Rotate Left Relay Coil															X			
Platform Rotate Left Relay Contacts															X			
Platform Rotate Switch															X			
Level Switch																	X	
Max Jib Angle Hg Switch												X						
Lift / Lower Joystick								X	X									
Swing Joystick															X			
Ext / Ret Joystick										X	X							
Steer Right Switch				X														
Steer Left Switch					X													
Interlock Switch		X	X	X														
Drive Joystick		X	X	X	X	X												
Torque Switch		X	X															
Foot Switch						X	X	X	X	X	X	X	X	X	X	X	X	
Platform E / Stop	X	X	X	X	X	X	X	X	X	X	X	X	X	X	X	X	X	
Oil Pressure Lamp (Orange)	X																	
Tilt Lamp (Red)		X	X	X	X	X	X	X	X	X	X	X	X	X	X	X	X	X
Tilt Alarm								X	X	X	X	X	X	X	X	X	X	X
Cage Stowed Relay Coil				X													X	
Cage Stowed Relay Contacts				X													X	
Multi Function Relay Coil								X	X	X	X	X	X				X	X
Multi Function Relay Contacts								X	X	X	X	X	X				X	X
Fuel Select Switch	X																	
Start Switch Platform	X																	
Aux Power Switch Platform																		X
Chassis E / Stop	X																	
Circuit Breaker	X																	
Circuit Breaker	X																	
Circuit Breaker 10 Amp	X																	
Key Switch	X																	
Aux Power Switch Chassis																		X
Chassis Control Power Relay Coil								X	X	X	X	X	X	X	X	X	X	
Chassis Control Power Relay Contacts								X	X	X	X	X	X	X	X	X	X	
Lower Control Interlock Switch								X	X	X	X	X	X	X	X	X		
Lower Control Start Switch	X																	
High Pressure Extend Relay Coil										X								
High Pressure Extend Relay Contacts										X								
High Pressure Extend Solenoid										X								

## 5.0 Introduction

This section contains electrical and hydraulic power schematics, and associated information for maintenance purposes.

The diagrams are to be used in conjunction with Section 4 "*Troubleshooting*". They allow understanding of the makeup and functions of the systems for checking, tracing, and faultfinding during trouble analysis.

The components that comprise the electrical and hydraulic systems are given a reference designation and are explained as to function and location in the following tables.

### *Section 5-1 Electrical Schematics*

Figure 5-1 Electrical Schematic, Gas Model

Figure 5-2 Electrical Schematic, Diesel Model

Figure 5-3 Electrical Schematic, Dual Fuel Model

### *Section 5-2 Hydraulic Schematics*

Figure 5-4 Hydraulic Schematic

Main Valve Block Assembly

*Section 5-3 Differential Lock (Valve Block Assembly)*

*Section 5-4 Front & Rear Drive Check valves*

*Section 5-5 Motion Control (Valve Block Assembly)*

*Section 5-6 Lower Controller Assembly - Diesel*

*Section 5-7 Lower Controller Assembly - Gas*

*Section 5-8 Upper Controller Assembly - Diesel*

*Section 5-9 Upper Controller Assembly - Gas*

*Section 5-10 Engine Module Assembly - Diesel*

*Section 5-11 Engine Module Assembly - Gas*

## 5.1 Electrical Schematics- Gas 100026-000

**Table 5-1: Electrical Schematic Legend, Gasoline Model - 100026-000**

REFERENCE DESIGNATION	NAME	FUNCTION	LOCATION
ALM1	Tilt Alarm	Sounds audible warning when level sensor trips R8	Upper Control Assy
ALM2	Horn	Warning Alarm	Chassis
ALT1	Alternator	Charge battery	Eng Module Assy
BATT1	Battery, 12V	Main Power	Eng Module Assy
BATT2	Battery, 12V	Aux Power	Chassis
BCH1	Battery Charge Isolator	Selects battery for charging	Engine Module Assy
C1	Controller	Drive	Upper Control Assy
C2	Controller	Boom Extend	Upper Control Assy
C3	Controller	Turret Rotate	Upper Control Assy
C4	Controller	Lift/Lwr	Upper Control Assy
C5	Controller	Superflex	Lower Control Assy
C6	Controller	Governor	Lower Control Assy
CB1	Breaker, 20A	Main Power	Lower Control Assy
CB2	Breaker, 20A	Main Power	Lower Control Assy
CB3	Breaker, 20A	Main Power	Lower Control Assy
COIL1	Coil	Provide spark to distributo	Eng Module Assy
D3	Diode	Ignition Block (Aux)	Upper Control Assy
D4	Diode	Ignition Block	Upper Control Assy
D5	Diode	Power to ignition Circuit	Lower Control Assy
D6	Diode	Interlock	Lower Control Assy
D7	Diode	Dump	Lower Control Assy
D8	Diode	Interlock signal to Superflex	Upper Control Assy
D9	Diode	Spike Protection	Upper Control Assy
D10	Diode	Spike Protection	Upper Control Assy
D11	Diode	Spike Protection	Upper Control Assy
D12	Diode	Spike Protection	Upper Control Assy
D13	Diode	Boom Power (Jib Up)	Upper Control Assy
D14	Diode	Boom Power (Jib Down)	Upper Control Assy
D15	Diode	Boom Power (Cage Right)	Upper Control Assy
D16	Diode	Boom Power (Cage Left)	Upper Control Assy
D17	Diode	Spike Protection	Lower Control Assy
D18	Diode	Spike Protection	Lower Control Assy
D19	Diode	Spike Protection	Lower Control Assy
D20	Diode	Spike Protection	Lower Control Assy
D21	Diode	Spike Protection	Lower Control Assy
D22	Diode	Spike Protection	Lower Control Assy
D23	Diode	Superflex Power	Lower Control Assy
D24	Diode	Dump Control	Lower Control Assy
D25	Diode	Steer Right	Lower Control Assy
D26	Diode	Steer Left	Lower Control Assy
D27	Diode	Spike Protection	Lower Control Assy
D28	Diode	Spike Protection	Lower Control Assy
D29	Diode	Spike Protection	Lower Control Assy
D30	Diode	Spike Protection	Lower Control Assy
D31	Diode	Spike Protection	Lower Control Assy
D32	Diode	Spike Protection	Lower Control Assy
D33	Diode	Spike Protection	Lower Control Assy
D34	Diode	Spike Protection	Lower Control Assy
D35	Diode	Power to Boom Power Relay	Lower Control Assy
D36	Diode	Fuel Pump	Engine Module
D37	Diode	Power Switch	Lower Control Assy
D38	Diode	Power Switch	Lower Control Assy
D39	Diode	To Mid Range Throttle	Lower Control Assy
D40	Diode	Platform to Boom Power Relay	Lower Control Assy
D41	Diode	Boom Power	Lower Control Assy
D42	Diode	Dump Mid/Throt	Lower Control Assy
D43	Diode	Foot Interlock to Swing Control	Upper Control Assy
D44	Diode	Hand Interlock to Swing Control	Upper Control Assy
D45	Diode	Hand Interlock to Superflex	Upper Control Assy
DSTR1	Distributor	Provides spark to plugs	Eng Module Assy
L1	Oil Press Lamp	Lights on low pressure	Upper Control Assy
L2	Tilt Lamp	Lights on excessive angle	Upper Control Assy
MTR1	Hour Meter	Tracks hours run	Lower Control Assy
MTR2	Oil Press Meter	Displays oil pressure	Lower Control Assy
MTR3	Water Temp Meter	Displays water temperature	Lower Control Assy
PMP1	Main Pump	Supplies oil to hydraulics	Eng Module Assy
PMP2	Aux Pump	Supplies oil to hydraulics	Eng Module Assy
PMP3	Fuel Pump	Supplies fuel to engine	Eng Module Assy
R1	Relay	Shift	Lower Control Assy
R2	Relay	Steer R	Lower Control Assy
R3	Relay	Steer L	Lower Control Assy

REFERENCE DESIGNATION	NAME	FUNCTION	LOCATION
R4	Relay	Trim Up	Lower Control Assy
R5	Relay	Trim Dn	Lower Control Assy
R6	Relay	Axle Lock	Lower Control Assy
R7	Relay	Aux Power	Lower Control Assy
R8	Relay	Tilt	Lower Control Assy
R9	Relay	Dump/Mid Throt	Lower Control Assy
R10	Relay	Brake/High Throt	Lower Control Assy
R11	Relay	Boom Power	Lower Control Assy
R12	Relay	Ignition	Lower Control Assy
R13	Relay	Start	Lower Control Assy
R14	Relay	Hi Press Extend	Lower Control Assy
R15	Relay	Power Switch	Lower Control Assy
R16	Relay	Chassis Cont Power	Lower Control Assy
R20	Relay	Platform Cont Power	Lower Control Assy
R21	Relay	Multi-Func Cut-Out	Upper Control Assy
R22	Relay	Cage Stowed	Upper Control Assy
R23	Relay	Cage Left	Upper Control Assy
R24	Relay	Cage Right	Upper Control Assy
R25	Relay	Jib Down	Upper Control Assy
R26	Relay	Jib Up	Upper Control Assy
R27	Relay	Horn	Lower Control Assy
S1	Switch	Level	Upper Control Assy
S2	Switch	Jib	Upper Control Assy
S3	Switch	Platform Rotate	Upper Control Assy
S4	Switch	Aux Power	Upper Control Assy
S5	Switch	Torque	Upper Control Assy
S7	Switch	Emergency Stop	Upper Control Assy
S8	Switch	Emergency Stop	Upper Control Assy
S9	Switch	Emergency Stop	Upper Control Assy
S10	Switch	Foot Interlock	Upper Control Assy
S11	Switch	Start	Lower Control Assy
S12	Switch	Aux Power	Lower Control Assy
S13	Switch	Level	Lower Control Assy
S14	Switch	Jib	Lower Control Assy
S15	Switch	Platform Rotate	Lower Control Assy
S16	Switch	Lift/Lower	Lower Control Assy
S17	Switch	Swing	Lower Control Assy
S18	Switch	Extend/Retract	Lower Control Assy
S19	Switch	Interlock	Upper Control Assy
S20	Switch	Chassis/Platform Key Switch	Lower Control Assy
S21	Switch	Emergency Stop	Lower Control Assy
S22	Switch	Max Platform Angle Limit	Chassis
S23	Switch	Proximity Switch	Inside Turret next to Boom pivot
S24	Switch	High Drive Interlocks Extend	End of Base Boom under Carrier Track
S26	Switch	Oil Pressure	Control Module
SOL1	Solenoid	Jib Up	Chassis
SOL2	Solenoid	Jib Down	Chassis
SOL3	Solenoid	Cage Rotate Right	Chassis
SOL4	Solenoid	Cage Rotate Left	Chassis
SOL5	Solenoid	Shift	Lower Control Assy
SOL6	Solenoid	Steer Right	Lower Control Assy
SOL7	Solenoid	Steer Left	Lower Control Assy
SOL8	Solenoid	Trim Up	Lower Control Assy
SOL9	Solenoid	Trim Down	Lower Control Assy
SOL10	Solenoid	Axle Lock	Lower Control Assy
SOL11	Solenoid	Lift Up	Lower Control Assy
SOL12	Solenoid	Lift Down	Lower Control Assy
SOL13	Solenoid	Swing Left	Lower Control Assy
SOL14	Solenoid	Swing Right	Lower Control Assy
SOL15	Solenoid	Extend	Lower Control Assy
SOL16	Solenoid	Retract	Lower Control Assy
SOL17	Solenoid	Dump	Lower Control Assy
SOL18	Solenoid	Brake	Lower Control Assy
SOL19	Solenoid	Boom	Lower Control Assy
SNSR1	Level Sensor	Trip R8 on excess tilt	Control Module
SNSR2	Oil Press Sending Unit	Provides input to oil pressure meter	Eng Module Assy
SNSR3	Temp Sending Unit	Provides input to temperature meter	Eng Module Assy
STR1	Starter	Turns engine	Eng Module Assy

100026-000

11X17

page to be placed here. This page is FPO

## 5.1 Electrical Schematics - Diesel 100026-004

**Table 5-2: Electrical Schematic Legend, Diesel Model - 100026-004**

REFERENCE DESIGNATION	NAME	FUNCTION	LOCATION
A1	Tilt Alarm	Sounds audible warning when level sensor trips R8	Upper Control Assy
A2	Horn	Warning Alarm	Chassis
ALT1	Alternator	Charge battery	Eng Module Assy
BATT1	Battery, 12V	Main Power	Eng Module Assy
BATT2	Battery, 12V	Aux Power	Chassis
BCI1	Battery Charge Isolator	Selects battery for charging	Engine Module Assy
C1	Controller	Drive	Upper Control Assy
C2	Controller	Boom Extend	Upper Control Assy
C3	Controller	Boom Lift/Turret Rotate	Upper Control Assy
C4	Controller	Superflex	Lower Control Assy
C5	Controller	Governor	Eng Module Assy
CB1	Breaker, 20A	Main Power	Lower Control Assy
CB2	Breaker, 20A	Main Power	Lower Control Assy
CB3	Breaker, 20A	Main Power	Lower Control Assy
D1	Diode	Ignition Block (Aux)	Upper Control Assy
D2	Diode	Ignition Block	Upper Control Assy
D3	Diode	Swing Control	Upper Control Assy
D4	Diode	Manual Controls	Upper Control Assy
D5	Diode	Manual Controls	Upper Control Assy
D6	Diode	Spike Protection	Upper Control Assy
D7	Diode	Spike Protection	Upper Control Assy
D8	Diode	Spike Protection	Upper Control Assy
D9	Diode	Spike Protection	Upper Control Assy
D10	Diode	Boom Power (Jib Up)	Upper Control Assy
D11	Diode	Boom Power (Jib Down)	Upper Control Assy
D12	Diode	Boom Power (Cage Right)	Upper Control Assy
D13	Diode	Boom Power (Cage Left)	Upper Control Assy
D14	Diode	Swing Control	Upper Control Assy
D15	Diode	Ignition Block	Upper Control Assy
D16	Diode	Ignition Block	Lower Control Assy
D17	Diode	Lower Control Interlock	Lower Control Assy
D18	Diode	Spike Protection	Lower Control Assy
D19	Diode	Spike Protection	Lower Control Assy
D20	Diode	Spike Protection	Lower Control Assy
D21	Diode	Spike Protection	Lower Control Assy
D22	Diode	Spike Protection	Lower Control Assy
D23	Diode	Spike Protection	Lower Control Assy
D24	Diode	Steer Left	Lower Control Assy
D25	Diode	Steer Right	Lower Control Assy
D26	Diode	Dump Control	Lower Control Assy
D27	Diode	Governor Control Isolation	Lower Control Assy
D28	Diode	Governor Control Isolation	Lower Control Assy
D29	Diode	Superflex Power	Lower Control Assy
D30	Diode	Aux Power Isolation (Dump)	Lower Control Assy
D31	Diode	Aux Power Isolation (Boom)	Lower Control Assy
D32	Diode	Aux Power Isolation (Boom)	Lower Control Assy
D33	Diode	Main/Aux Power Isolation	Lower Control Assy
D34	Diode	Main/Aux Power Isolation	Lower Control Assy
D35	Diode	Glow Block	Lower Control Assy
D36	Diode	Main/Aux Power Isolation	Lower Control Assy
D37	Diode	Alternator Isolation	Eng Module Assy
L1	Oil Press Lamp	Lights on low pressure	Upper Control Assy
L2	Tilt Lamp	Lights on excessive angle	Upper Control Assy
MTR1	Hour Meter	Records hours run	Lower Control Assy
MTR2	Oil Press Meter	Displays oil pressure	Lower Control Assy
MTR3	Water Temp Meter	Displays water temperature	Lower Control Assy
PMP1	Main Pump	Supplies oil to hydraulics	Eng Module Assy
PMP2	Aux Pump	Supplies oil to hydraulics	Eng Module Assy
R1	Relay	Shift	Lower Control Assy
R2	Relay	Steer R	Lower Control Assy
R3	Relay	Steer L	Lower Control Assy
R4	Relay	Trim Up	Lower Control Assy
R5	Relay	Trim Dn	Lower Control Assy
R6	Relay	Axle Lock	Lower Control Assy
R7	Relay	Aux Power	Lower Control Assy
R8	Relay	Tilt	Lower Control Assy
R9	Relay	Dump/Mid Throt	Lower Control Assy
R10	Relay	Brake/High Throt	Lower Control Assy
R11	Relay	Boom Power	Lower Control Assy
R12	Relay	Ignition	Lower Control Assy

REFERENCE DESIGNATION	NAME	FUNCTION	LOCATION
R13	Relay	Start	Lower Control Assy
R14	Relay	Hi Press Extend	Lower Control Assy
R15	Relay	Power Switch	Lower Control Assy
R16	Relay	Chassis Cont Power	Lower Control Assy
R17	Relay	Glow Plug	Eng Module Assy
R18	Relay	Fuel Shutoff	Eng Module Assy
R19	Relay	Glow	Lower Control Assy
R20	Relay	Platform Cont Power	Lower Control Assy
R21	Relay	Multi-Func Cut-Out	Upper Control Assy
R22	Relay	Cage Stowed	Upper Control Assy
R23	Relay	Cage Left	Upper Control Assy
R24	Relay	Cage Right	Upper Control Assy
R25	Relay	Jib Down	Upper Control Assy
R26	Relay	Jib Up	Upper Control Assy
R27	Relay	Horn	Lower Control Assy
R28	Throttle Relay	Intermediate Speed	Engine Module
R29	Throttle Relay	High Speed	Engine Module
S1	Switch	Level	Upper Control Assy
S2	Switch	Jib	Upper Control Assy
S3	Switch	Platform Rotate	Upper Control Assy
S4	Switch	Aux Power	Upper Control Assy
S5	Switch	Glow Plugs	Upper Control Assy
S6	Switch	Torque	Upper Control Assy
S7	Switch	Emergency Stop	Upper Control Assy
S8	Switch	Emergency Stop	Upper Control Assy
S9	Switch	Emergency Stop	Upper Control Assy
S10	Switch	Ignition	Upper Control Assy
S11	Switch	Horn	Upper Control Assy
S12	Switch	Max Platform Angle Limit	Chassis
S13	Switch	Oil Pressure	Chassis
S14	Switch	Proximity Switch	Inside Turret near Boom pivot
S15	Switch	Foot Interlock	Upper Control Assy
SOL1	Solenoid	Jib Up	Chassis
SOL2	Solenoid	Jib Down	Chassis
SOL3	Solenoid	Cage Rotate Right	Chassis
SOL4	Solenoid	Cage Rotate Left	Chassis
SOL5	Solenoid	Shift	Lower Control Assy
SOL6	Solenoid	Steer Right	Lower Control Assy
SOL7	Solenoid	Steer Left	Lower Control Assy
SOL8	Solenoid	Trim Up	Lower Control Assy
SOL9	Solenoid	Trim Down	Lower Control Assy
SOL10	Solenoid	Axle Lock	Lower Control Assy
SOL11	Solenoid	Lift Up	Lower Control Assy
SOL12	Solenoid	Lift Down	Lower Control Assy
SOL13	Solenoid	Swing Left	Lower Control Assy
SOL14	Solenoid	Swing Right	Lower Control Assy
SOL15	Solenoid	Extend	Lower Control Assy
SOL16	Solenoid	Retract	Lower Control Assy
SOL17	Solenoid	Dump	Lower Control Assy
SOL18	Solenoid	Brake	Lower Control Assy
SOL19	Solenoid	Boom	Lower Control Assy
SOL20	Solenoid	Engages eng starter	Eng Module Assy
SOL21	Solenoid	Extend high pressure	Lower Control Assy
SOL22	Solenoid	Fuel Shutoff	Eng Module Assy
SNSR1	Level Sensor	Trip R8 on excess tilt	Lower Control Assy
SNSR2	Oil Press Sending Unit	Provides input to oil pressure meter	Eng Module Assy
SNSR3	Temp Sending Unit	Provides input to temperature meter	Eng Module Assy
STR1	Starter	Turns engine	Eng Module Assy
SW1	Switch	Glow	Lower Control Assy
SW2	Switch	Extend/Retract	Lower Control Assy
SW3	Switch	Level/Trim	Lower Control Assy
SW4	Switch	Start	Lower Control Assy
SW5	Switch	Lift/Lower	Lower Control Assy
SW6	Switch	Platform Rotate	Lower Control Assy
SW7	Switch	Keypresswitch - Selector	Lower Control Assy
SW8	Switch	Enable	Lower Control Assy
SW9	Switch	Jib	Lower Control Assy
SW10	Switch	Emergency Stop	Lower Control Assy
SW11	Switch	Aux Power	Lower Control Assy
SW12	Switch	Swing - Slew	Lower Control Assy
SW13	Switch	Oil Pressure	Eng Module Assy

**100026-003**

**11X17**

**page to be placed here. This page is FPO**



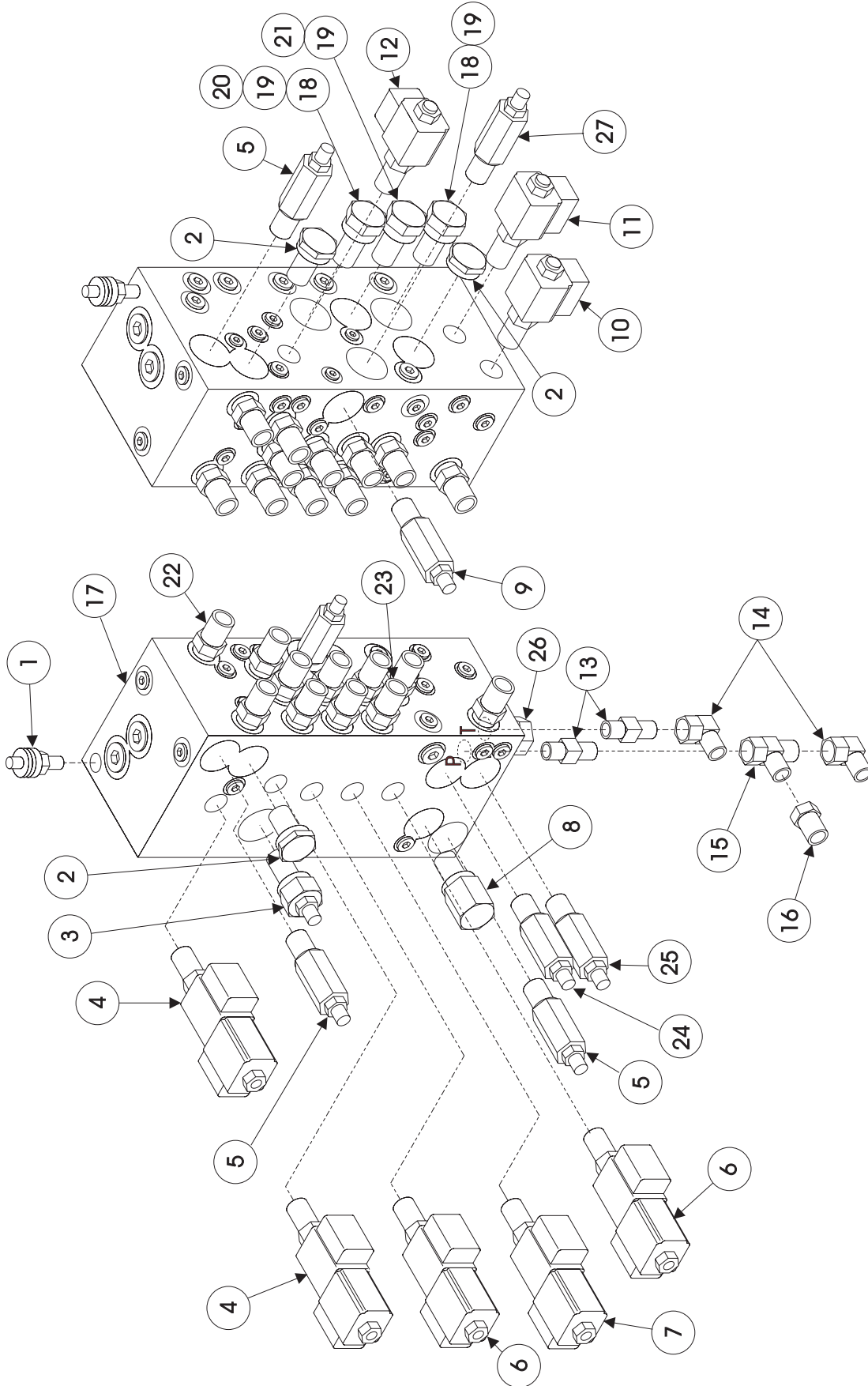








# Schematics

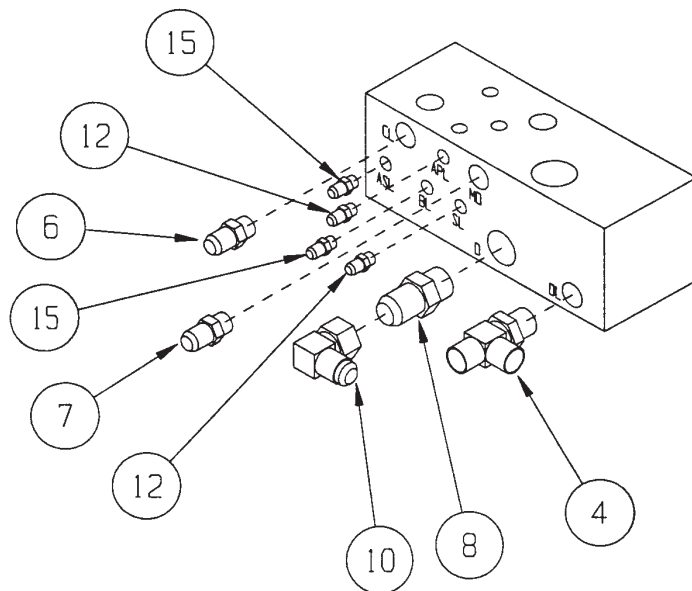
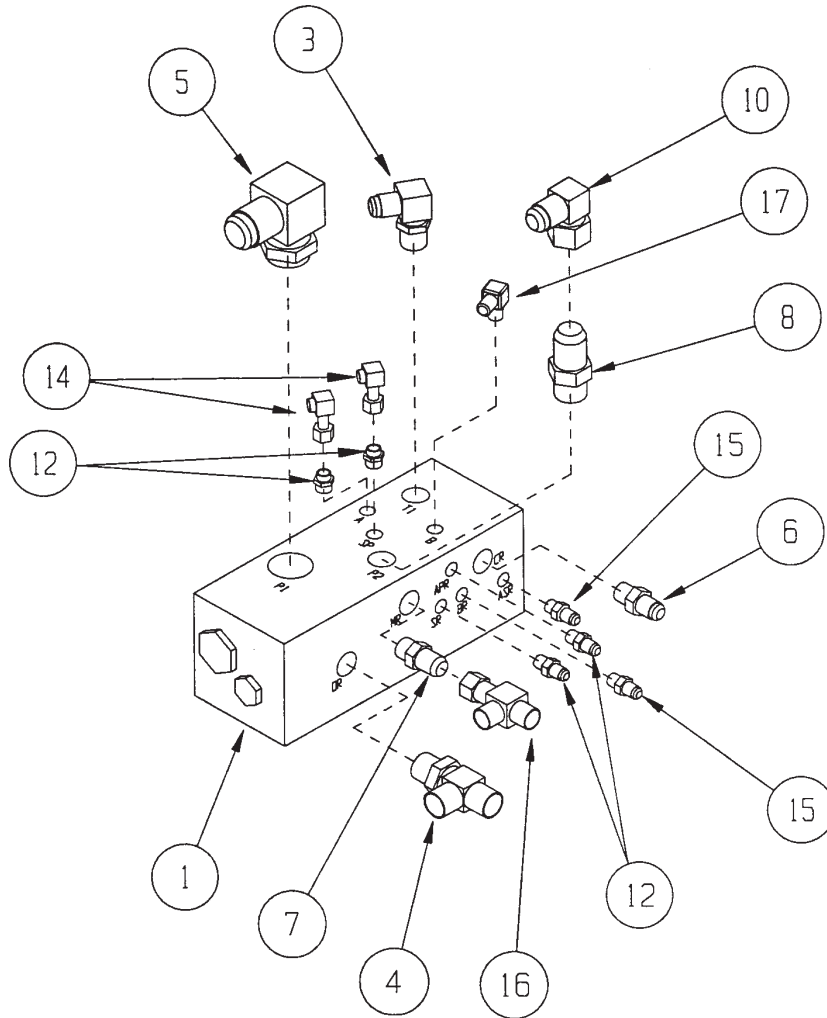


## VALVE BLOCK ASSEMBLY, MAIN

100264-000

ITEM	PART	DESCRIPTION	QTY.
1	063965-001	FITTING TEST	1
2	100245-010	CHECK VALVE (30PSI)	3
3	100245-014	FLOW CONTROL VALVE	1
4	100245-008	3/4 WAY SOLENOID VALVE (CLOSEDCENTER)	1
5	100245-027	RELIEF VALVE	2
6	100245-007	3/4 WAY PROP. DIR. VALVE (FLOATINGCENTER)	2
7	100245-030	3/4 WAY PROP. DIR. VALVE (CLOSEDCENTER)	1
8	100245-004	DIVERTER VALVE	1
9	100245-026	RELIEF VALVE	1
10	100245-012	2/2 WAY SOLENOID VALVE N/O	1
11	100245-002	2/2 WAY SOLENOID VALVE N/O	1
12	100245-013	2/2 WAY SOLENOID VALVE N/C	1
13	011941-010	FITTING 8MB-8MJ ST	2
14	011937-004	FITTING 8FJ-8MJ 90°	2
15	020733-003	FITTING 8FJ-8MJ-8MJ	1
16	014693-004	FITTING 8FJ-6MJ ST	1
17	100245-001	VALVE BLOCK, STERLING #9S000501-E	1
18	100245-005	DIVERTER VALVE	1
19	100245-023	ORIFICE PLUG	6
20	100245-017	ORIFICE PLUG	1
21	100245-016	COMPENSATOR	1
22	011941-004	FITTING 6MB-4MJ	1
23	011941-005	FITTING 6MB-6MJ	10
24	100245-028	RELIEF VALVE	1
25	100245-024	RELIEF VALVE	1
26	100245-011	SHUTTLE VALVE	1
27	100245-025	RELIEF VALVE	1

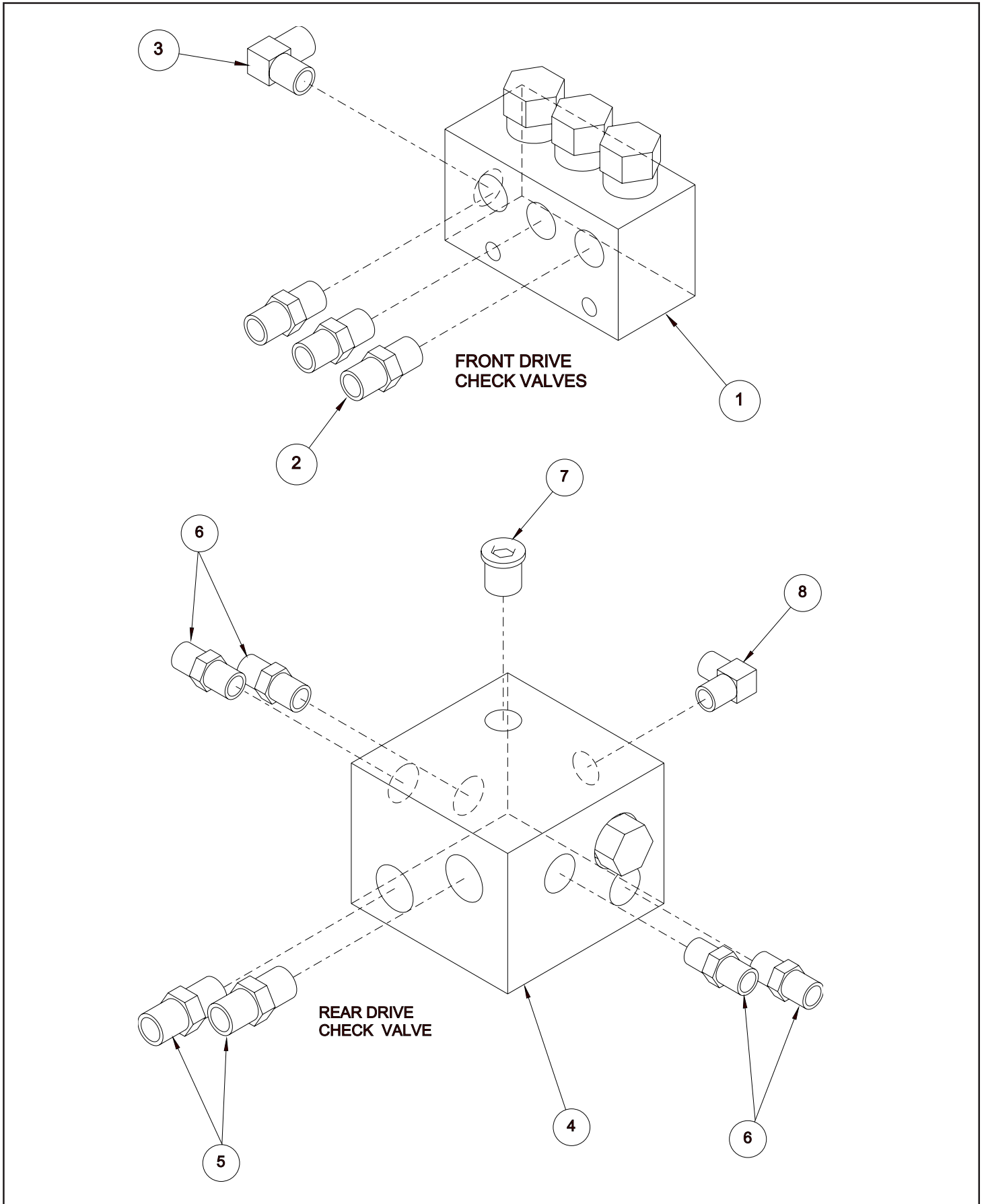
# Schematics



## ***Differential Lock (Valve Block Assembly) 100317-000***

ITEM	PART	DESCRIPTION	QTY.
1	100282-000	DIFF-LOCK VALVE BLOCK	1
3	011934-013	FITTING, 90° ADAPTER 12MB-8MJ	1
4	100444-004	FITTING, TEE 8MFFOR-8MB-8MFFOR	2
5	100434-023	FITTING, 90° ADAPTER 12MFFOR-16MB	1
6	011941-010	FITTING, STR. ADAPTER 8MB-8MJ	2
7	100432-015	FITTING, STR. ADAPTER 8MFFOR-8MB	2
8	100432-027	FITTING, STR. ADAPTER 12MFFOR-12MB	2
10	100435-005	FITTING, 12MFFORS-12FFORS90°	2
11	100433-001	FITTING, 45° 4MFFOR-4MB	1
12	100432-002	FITTING, STR. 4MFFOR-4MB	6
14	100435-001	FITTING, 4MFFORS-4FFORS90°	2
15	011941-001	FITTING STR. ADAPTER 4MB-4MJ	4
16	100448-002	FITTING, TEE FF2114T-0808S	1
17	011934-001	FITTING 90° ADAPTER 4MB-4MJ	1

# Schematics

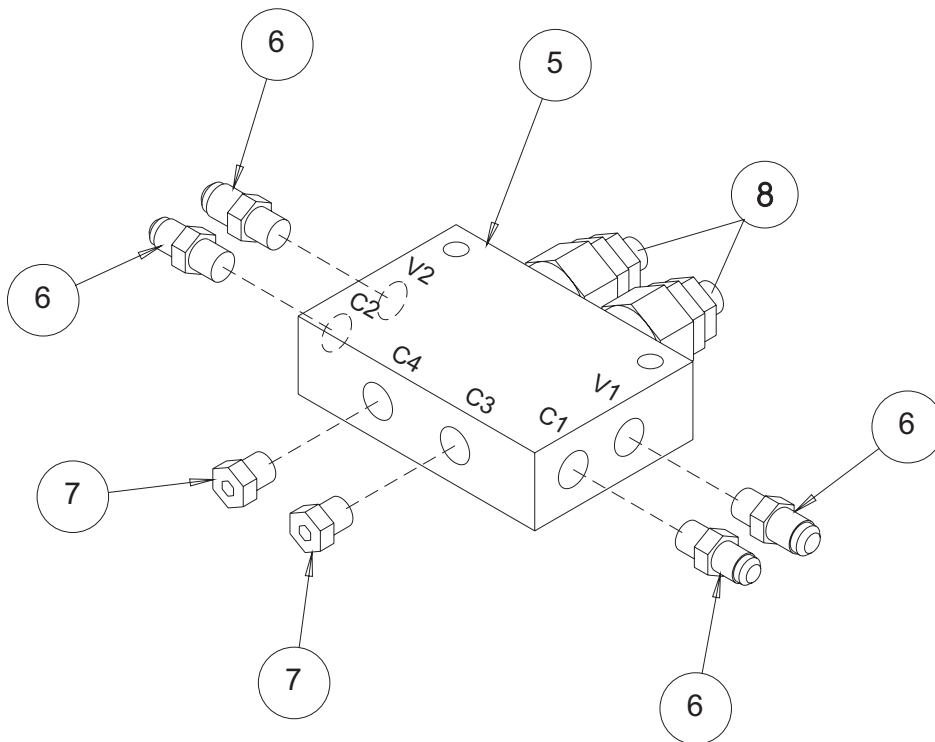
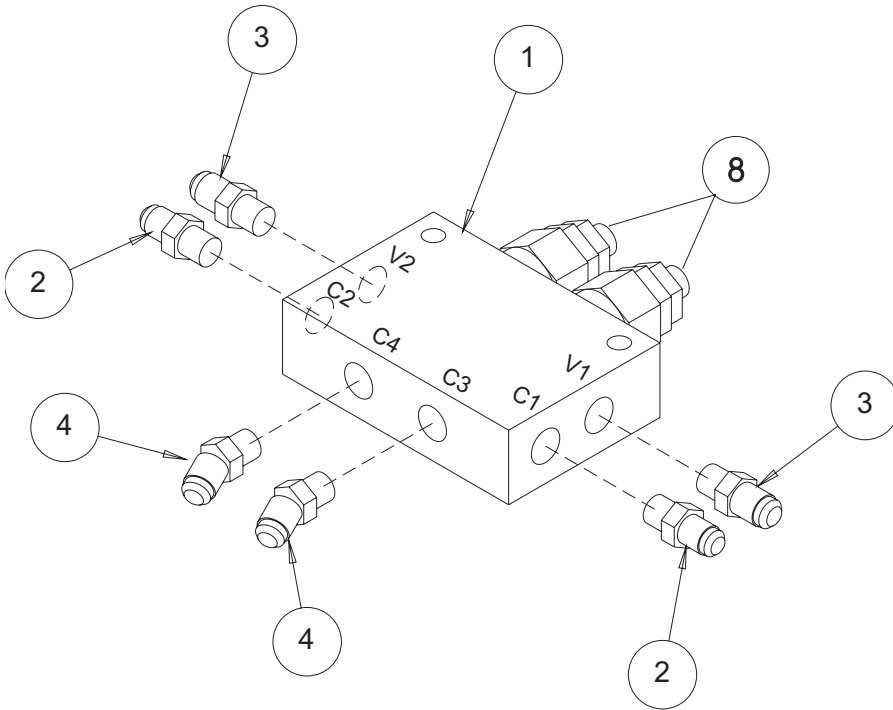




## ***Front & Rear Drive Check Valves (Valve Block Assembly) 100716-000 & 100717-000***

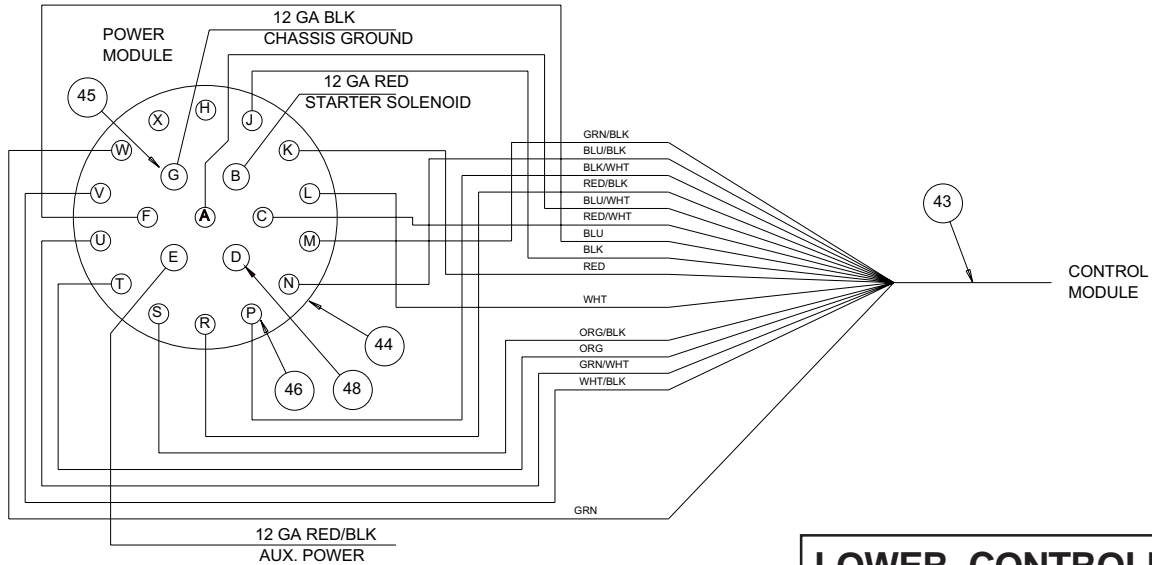
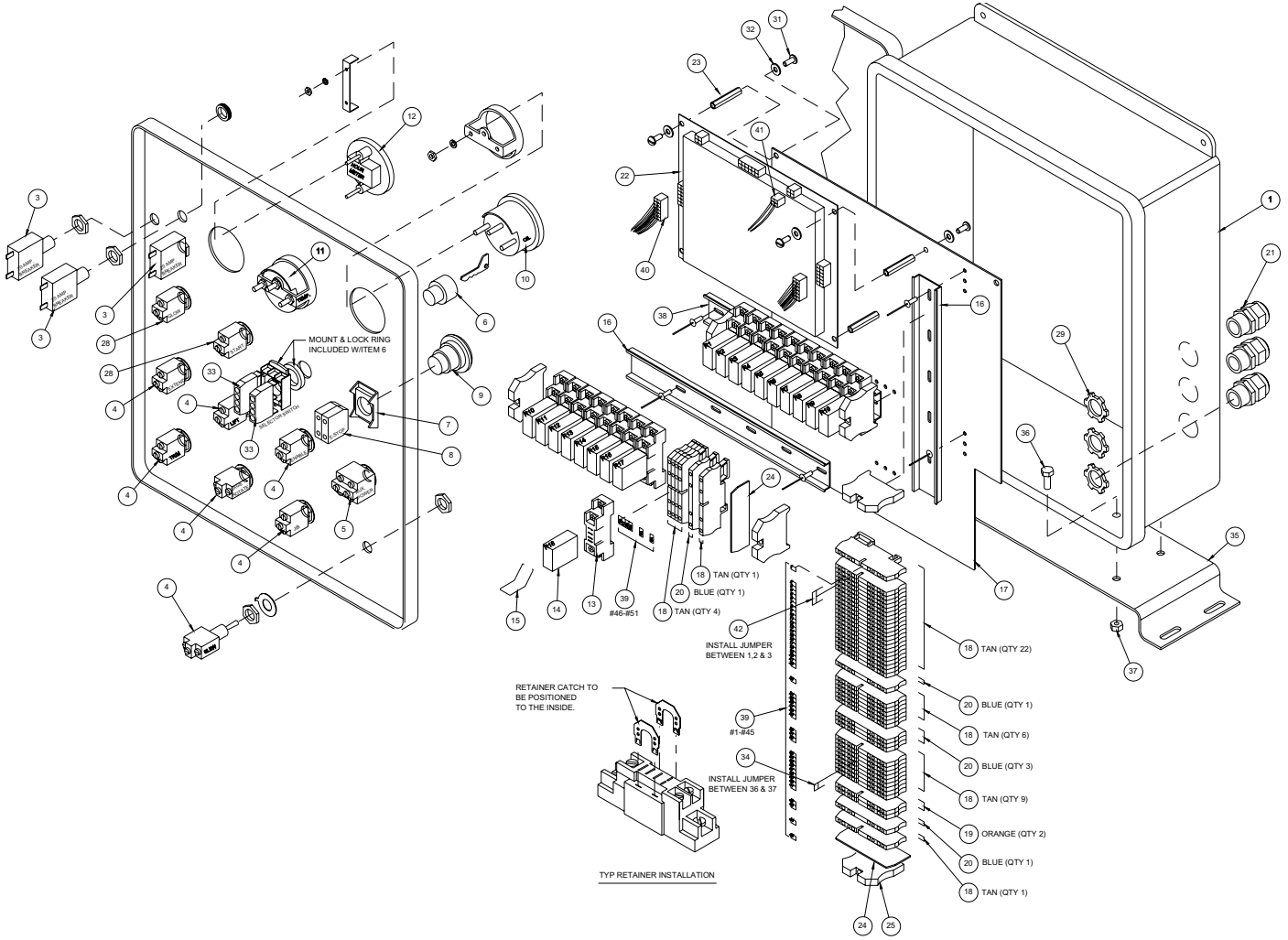
<b>ITEM</b>	<b>PART</b>	<b>DESCRIPTION</b>	<b>QTY.</b>
1	100713-000	VALVE BLOCK, ANTI-CAV CHECK	1
2	100432-015	FITTING 8MB-8MFFOR STRAIGHT	3
3	011934-007	FITTING 8MB-6MJ90° ELBOW	1
4	100714-000	VALVE BLOCK, 2 STATION CHECK	1
5	100432-027	FITTING 12MB-12MFFOR STRAIGHT	2
6	100432-016	FITTING 10MB-8MFFOR STRAIGHT	4
7	020021-008	FITTING 8MB PLUG	1
8	011934-007	FITTING 8MB-6MJ90° ELBOW	1

# Schematics



## ***Motion Control (Valve Block Assembly) 100269-001 & 100269-002***

<b>ITEM</b>	<b>PART</b>	<b>DESCRIPTION</b>	<b>QTY.</b>
1	100269-000	VALVE BLOCK, STERLING#9S000520-A	1
2	011941-001	FITTING, STR. ADAPTER 4MB-4MJ	2
3	011941-002	FITTING, STR. ADAPTER 4MB-4MJ	2
4	011935-001	FITTING 45° 4MB-4MJ	2
5	100269-000	VALVE BLOCK, STERLING#9S000520-A	1
6	011941-001	FITTING, STR. ADAPTER 4MB-4MJ	4
7	20021-004	FITTING, PLUG 4MB	2
8	068778-000	VALVE, COUNTERBALANCE	2



**LOWER CONTROLLER ASSEMBLY, DIESEL**  
**100018-000**  
 DRAWING 1 OF 2

## Lower Controller Assembly, Diesel 100018-000

ITEM	PART	DESCRIPTION	QTY.
1	100307-000	ENCLOSURE	1
3	68582-020	CIRCUIT BREAKER, 20 AMP	3
4	12798-000	TOGGLE SWITCH, SPDT	7
5	12798-005	TOGGLE SWITCH, DPDT	1
6	100335-000	SELECTOR SWITCH, KEY OPERATED	1
7	64417-001	LATCH PLATE	1
8	64443-002	CONTACT BLOCK, NC	2
9	64446-003	OPERATOR, RED "MUSHROOM" BUTTON	1
10	100331-000	OIL PRESSURE GAUGE	1
11	100330-000	TEMPERATURE GAUGE	1
12	15752-000	HOUR METER	1
13	67662-001	BASE, RELAY SINGLE POLE	17
14	67661-001	RELAY, SINGLE POLE	17
15	67662-005	RETAINER CLIP, RELAY	17
16	67893-005	DIN RAIL 10-1/2" LENGTH	2
17	100316-000	MOUNTING PLATE	1
18	68698-001	TERMINAL BLOCK, TAN	43
19	68698-000	TERMINAL BLOCK, ORANGE	2
20	68698-002	TERMINAL BLOCK, BLUE	6
21	29925-001	CORD GRIP	3
22	100336-000	CONTROLLER "SUPER-FLEX" KIT	1
23	100299-000	SPACER	3
24	68698-004	END SECTION	2
25	67660-006	END BLOCK, LOCKING	6
26	26551-005	POP RIVET 1/8" DIA (3/16-1/4 GRIP)	6
28	012798-006	TOGGLE SWITCH	2
29	29939-003	LOCKNUT 3/4" NPT	3
31	11708-004	SCR, RD HD #8-32 UNC X 1/2	6
32	11240-003	WASHER, FLAT #10	6
33	68860-000	CONTACT BLOCK, NO DOUBLE	2
34	068773-002	JUMPER, 2 PIN	1
35	100315-000	MOUNTING BRACKET	1
36	11252-006	SCREW, HHC 1/4-20 X 3/4	4
37	11248-004	LOCKNUT, 1/4-20 UNC ESNA	4
38	67893-006	DIN RAIL 8-1/2" LENGTH	1
39	100298-000	NUMBER STRIP #1 - #50	1
40	100336-015	WIRE HARNESS	2
41	100336-016	WIRE HARNESS	1
42	068773-003	JUMPER, 3 PIN	1
43	060214-099	CABLE 16 GA 15 COND	FT 11
44	100338-001	CONNECTOR, FEMALE 21 PIN	1
45	100338-011	CONN, 12 GA PIN	3
46	100338-013	CONN, 16 GA PIN	15
47	100338-005	BOOT	1
48	068764-000	PLUG SEALING	3

SEENEXTPAGE

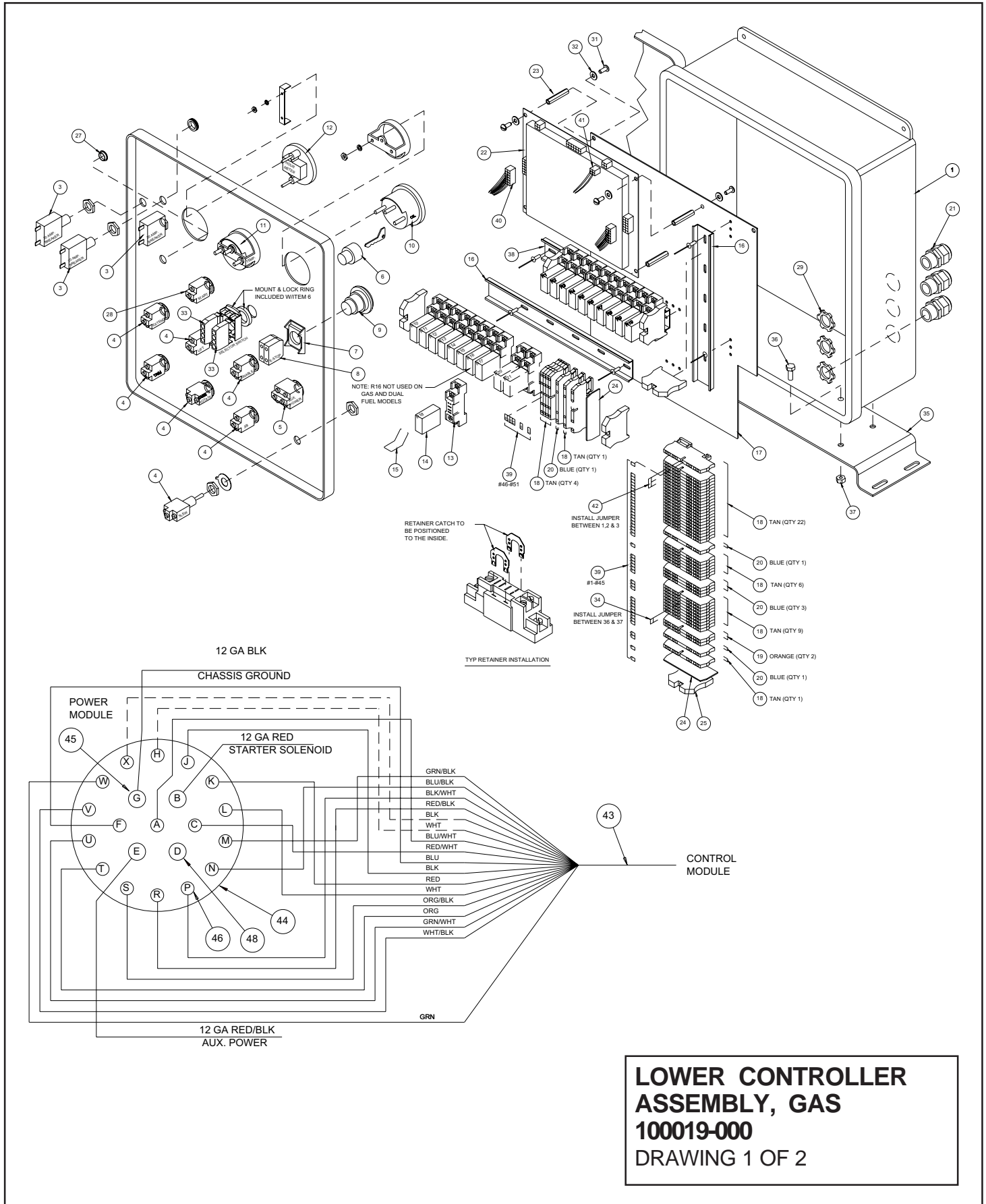
## Lower Controller Assembly, Diesel 100018-000

ITEM	PART	DESCRIPTION	QTY.
201	29452-099	WIRE, 16 GA BLACK FT	10
202	29451-099	WIRE, 16 GA WHITE FT	10
203	29454-099	WIRE, 16 GA RED FT	10
204	29457-099	WIRE, 16 GA GREEN FT	10
205	29479-099	WIRE, 16 GA WHITE/BLACK FT	10
206	29478-099	WIRE, 16 GA RED/BLACK FT	10
207	05491-099	WIRE, 16 GA GREEN/BLACK FT	10
208	29477-099	WIRE, 16 GA ORANGE/BLACK FT	10
209	29352-099	WIRE, 16 GA RED/WHITE FT	10
210	29353-099	WIRE, 16 GA GREEN/WHITE FT	10
211	29354-099	WIRE, 16 GA BLUE/WHITE FT	10
212	29358-099	WIRE, 16 GA BLUE/RED FT	10
213	29356-099	WIRE, 16 GA WHITE/RED FT	10
214	29360-099	WIRE, 16 GA ORANGE/GREEN FT	10
215	29475-099	WIRE, 16 GA BLUE/BLACK FT	10
216	29453-099	WIRE, 16 GA ORANGE FT	10
217	29450-099	WIRE, 16 GA BLUE FT	10
218	29456-099	WIRE, 16 GA YELLOW FT	10
221	29472-099	WIRE, 12 GA BLACK FT	10
222	29470-099	WIRE, 12 GA RED FT	10
223	29466-099	WIRE, 14 GA WHITE FT	10
224	15747-002	DIODE, 1 - 1-1/2 AMP 1000 VOLT	7
225	29825-003	DIODE, 3 AMP 400 VOLT	23
227	29447-099	CABLE, 3 COND/16 AWG FT	7
228	100321-099	CABLE, 34 COND/18 GA -3 COND/10 GA FT	80
229	60214-099	CABLE, 15 COND/16 AWG FT	10
230	60214-099	CABLE, 15 COND/16 AWG FT	14
231	29490-099	CABLE, 2 COND/16 AWG FT	10
232	100380-000	SWITCH, LIFT INTERLOCK	1
233	029620-002	CONN BUTT 16-14 GA	10
234	29601-039	CONN RING (5/16 DIA) 12-10 GA	1
235	29617-003	CONN MALE PUSH (.25) 12-10 GA	2
236	29610-002	CONN FORK (#6 DIA) 16-14 GA	127
237	29610-003	CONN FORK (#6 DIA) 12-10 GA	3
238	29601-012	CONN RING (#8 DIA) 16-14 GA	6
239	29931-003	CONN FEM PUSH (.25) 16-14 GA	2
240	29931-005	CONN FEM PUSH (.25) 12-10 GA	6
241	29610-001	CONN FORK 22-18 GA #6	1

100018-2

11X17

page to be placed here. This page is FPO





## Lower Controller Assembly, Gas 100019-000

ITEM	PART	DESCRIPTION	QTY.
1	100307-000	ENCLOSURE	1
3	68582-020	CIRCUIT BREAKER, 20 AMP	3
4	12798-000	TOGGLE SWITCH, SPDT	7
5	12798-005	TOGGLE SWITCH, DPDT	1
6	100335-000	SELECTOR SWITCH, KEY OPERATED	1
7	64417-001	LATCH PLATE	1
8	64443-001	CONTACT BLOCK, NC	2
9	64446-003	OPERATOR, RED "MUSHROOM" BUTTON	1
10	100331-000	OIL PRESSURE GAUGE	1
11	100330-000	TEMPERATURE GAUGE	1
12	15752-000	HOUR METER	1
13	67662-001	BASE, RELAY SINGLE POLE	17
14	67661-001	RELAY, SINGLE POLE	17
15	67662-005	RETAINER CLIP, RELAY	17
16	67893-005	DIN RAIL 10-1/2" LENGTH	2
17	100316-000	MOUNTING PLATE	1
18	68698-001	TERMINAL BLOCK, TAN	43
19	68698-000	TERMINAL BLOCK, ORANGE	2
20	68698-002	TERMINAL BLOCK, BLUE	6
21	29925-001	CORD GRIP	3
22	100336-000	CONTROLLER "SUPER-FLEX" KIT	1
23	100299-000	SPACER	3
24	68698-004	END SECTION	2
25	67660-006	END BLOCK, LOCKING	6
26	26551-005	POP RIVET 1/8" DIA (3/16-1/4 GRIP)	6
27	66516-008	PLUG, 1/2" DIA	1
28	012798-006	TOGGLE SWITCH	1
29	29939-003	LOCK NUT 3/4" NPT	3
31	11708-004	SCR, RD HD #8-32 UNC X 1/2	6
32	11240-003	WASHER, FLAT #10	6
33	68860-000	CONTACT BLOCK, NO DOUBLE	2
34	068773-002	JUMPER, 2 PIN	1
35	100315-000	MOUNTING BRACKET	1
36	11252-006	SCREW, HHC 1/4-20 X 3/4	4
37	11248-004	LOCK NUT, 1/4-20 UNC ESNA	4
38	67893-006	DIN RAIL 8-1/2" LENGTH	1
39	100298-000	NUMBER STRIP #1 - #50	1
40	100336-015	WIRE HARNESS	2
41	100316-016	WIRE HARNESS	1
42	068773-003	JUMPER, 3 PIN	1
43	060214-099	CABLE 16 GA 15 COND	FT 11
44	100338-001	CONNECTOR, FEMALE 21 PIN	1
45	100338-011	CONNECTOR, 12 GA PIN	3
46	100338-013	CONNECTOR, 16 GA PIN	15
47	100338-005	BOOT	1
48	68764-000	PLUG SEALING	3

SEE NEXT PAGE

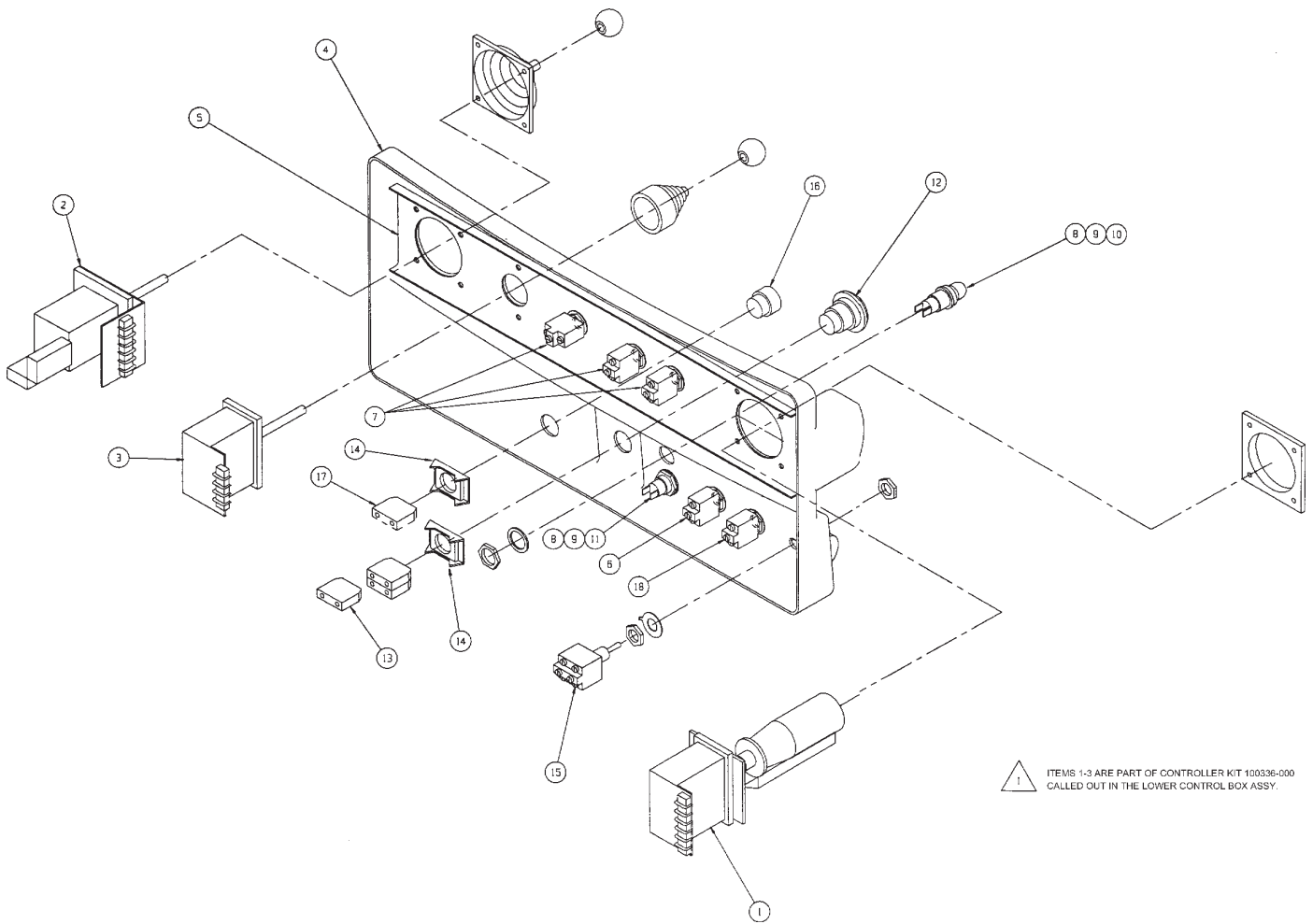
## Lower Control Assembly Gas 100019-000

ITEM	PART	DESCRIPTION	QTY.
201	29452-099	WIRE, 16 GA BLACK FT	10
202	29451-099	WIRE, 16 GA WHITE FT	10
203	29454-099	WIRE, 16 GA RED FT	10
204	29457-099	WIRE 16 GA GREEN FT	10
205	29479-099	WIRE, 16 GA WHITE/BLACK FT	10
206	29478-099	WIRE, 16 GA RED/BLACK FT	10
207	05491-099	WIRE, 16 GA GREEN/BLACK FT	10
208	29477-099	WIRE, 16 GA ORANGE/BLACK FT	10
209	29352-099	WIRE, 16 GA RED/WHITE FT	10
210	29353-099	WIRE, 16 GA GREEN/WHITE FT	10
211	29354-099	WIRE, 16 GA BLUE/WHITE FT	10
212	29358-099	WIRE, 16 GA BLUE/RED FT	10
213	29356-099	WIRE, 16 GA WHITE/RED FT	10
214	29360-099	WIRE, 16 GA ORANGE/GREEN FT	10
215	29475-099	WIRE, 16 GA BLUE/BLACK FT	10
216	29453-099	WIRE, 16 GA ORANGE FT	10
217	29450-099	WIRE, 16 GA BLUE FT	10
218	29456-099	WIRE, 16 GA YELLOW FT	10
222	29470-099	WIRE, 12 GA RED FT	10
223	29466-099	WIRE, 14 GA WHITE FT	10
224	15747-002	DIODE, 1 - 1-1/2 AMP 1000 VOLT	6
225	29825-003	DIODE, 3 AMP 400 VOLT	23
227	29447-099	CABLE, 3 COND/16 AWG FT	7
228	100321-099	CABLE, 34 COND/18 GA -3 COND/10 GA FT	80
229	60214-099	CABLE, 15 COND/16 AWG FT	10
230	60214-099	CABLE, 15 COND/16 AWG FT	14
231	29490-099	CABLE, 2 COND/16 AWG FT	10
232	100380-000	SWITCH, LIFT INTERLOCK	1
233	029620-002	CONN BUTT 16-14 GA	10
234	29601-039	CONN RING (5/16 DIA) 12-10 GA	1
235	29617-003	CONN MALE PUSH (.25) 12-10 GA	2
236	29610-002	CONN FORK (#6 DIA) 16-14 GA	127
237	29610-003	CONN FORK (#6 DIA) 12-10 GA	3
238	29601-012	CONN RING (#8 DIA) 16-14 GA	6
239	29931-003	CONN FEM PUSH (.25) 16-14 GA	2
240	29931-005	CONN FEM PUSH (.25) 12-10 GA	6
241	29610-001	CONN FORK 22-18 GA #6	1
242	29601-019	CONN T&B RC 367 12 GA RING	1

100019-000

11X17

page to be placed here. This page is FPO

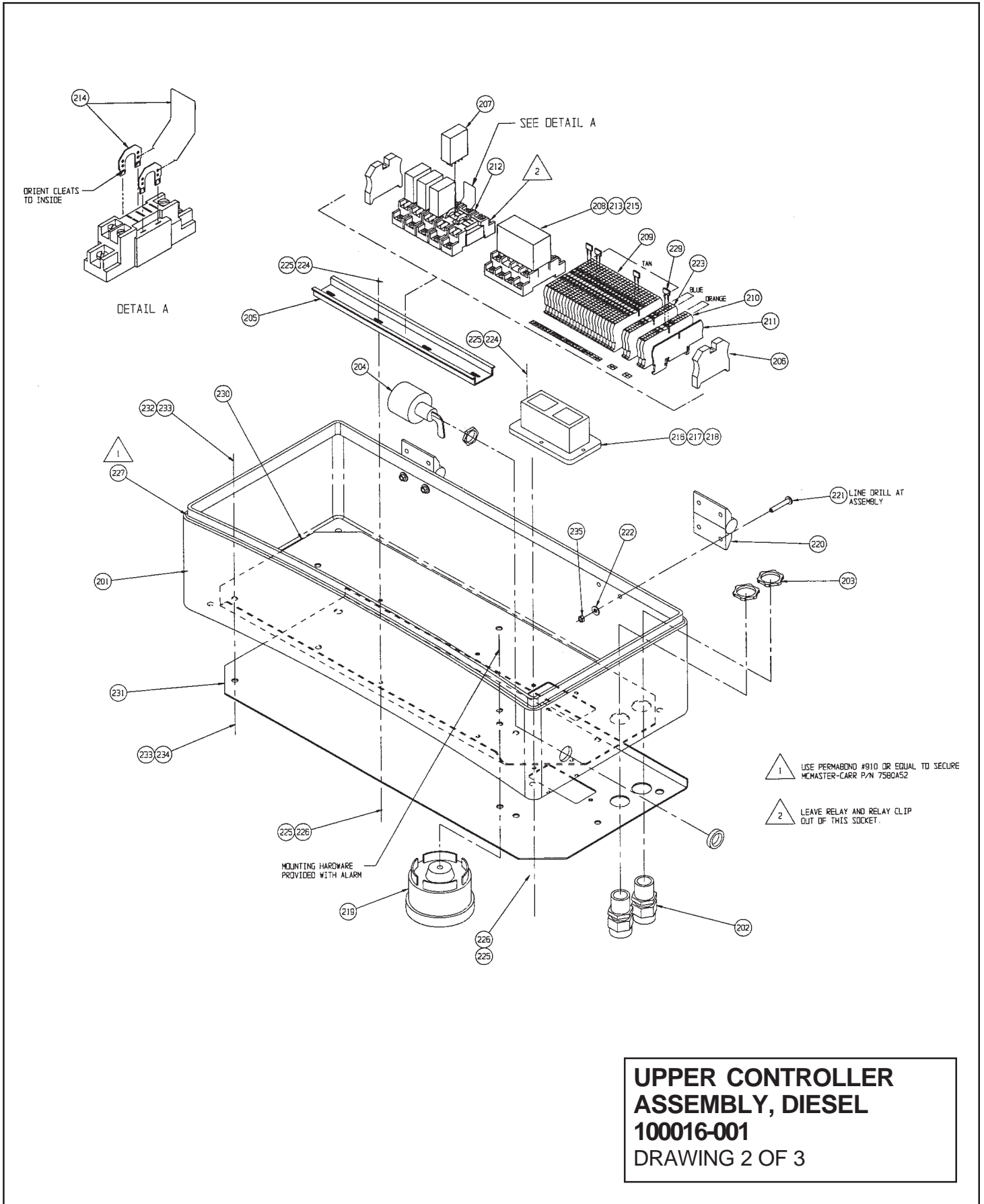


**UPPER CONTROLLER  
ASSEMBLY, DIESEL  
100016-001  
DRAWING 1 OF 3**

## *Upper Controller Assembly Diesel 100016-001*

ITEM	PART	DESCRIPTION	QTY.
1	100325-000	DRIVE CONTROLLER	REF
2	100326-000	LIFT CONTROLLER	REF
3	100327-000	EXTEND CONTROLLER	REF
4	100309-000	UPPER CONTROL BOX	1
5	100310-000	STIFFENER, UPPER CONTROLLER	1
6	012797-000	SWITCH TOGGLE SPDT MAINTAINED	1
7	012798-006	SWITCH TOGGLE SPDT MOMENTARY	3
8	068590-000	BASE INDICATOR LAMP	2
9	068591-001	LAMP T-2 1/2	2
10	068595-002	LENS AMBER	1
11	068595-001	LENS RED	1
12	064446-003	EMERGENCY STOP BUTTON	1
13	064443-002	CONTACT BLOCK NC	3
14	064417-001	FLANGE MOUNT	2
15	012798-005	SWITCH TOGGLE DPDT MOMENTARY	1
16	067654-000	PUSH BUTTON, FLUSH (BLACK)	1
17	064443-001	CONTACT BLOCK NO	1
18	012798-006	TOGGLE SWITCH	1

SEENEXTPAGE



**UPPER CONTROLLER  
ASSEMBLY, DIESEL  
100016-001  
DRAWING 2 OF 3**

## Upper Controller Assembly Diesel 100016-001

ITEM	PART	DESCRIPTION	QTY.
201	100309-000	UPPER CONTROL BOX	REF
202	029925-002	CONNECTOR CABLE 1/2 NPT	2
203	029939-002	LOCKNUT 1/2 NPT	2
204	100334-000	SWITCH, LEVER	1
205	067893-000	MOUNTING RAIL DIN X 13 LG	1
206	067660-006	TERMINAL END	2
207	067661-001	RELAY SPDT 12VDC	4
208	067661-004	RELAY 4PDT 12VDC	1
209	068698-001	TERMINAL BLOCK (TAN)	23
210	068698-000	TERMINAL BLOCK (ORANGE)	2
211	068698-004	END CAP, CONTACT BLOCK	1
212	067662-001	RELAY SOCKET SPDT	5
213	067662-004	RELAY SOCKET 4PDT	1
214	067662-005	RETAINER CLIP ASSY	4
215	067662-007	RETAINER CLIP ASSY	1
216	015790-006	CONNECTOR RECEPTACLE	1
217	015790-004	PIN CONTACT 16-18G	27
218	015790-007	PIN CONTACT 14-16G	3
219	066807-001	ALARM 107DB	1
220	100319-000	HINGE SOUTH CO C6-30	2
221	013965-006	SCREW HHC #10-24 X 3/4 LG	8
222	011240-003	WASHER #10 FLAT	8
223	068698-002	TERMINAL BLOCK (BLUE)	2
224	011715-006	SCREW RD HD MACHINE #6-32 X 3/4 LG	6
225	011240-001	WASHER #6 FLAT	12
226	011248-047	LOCKNUT #6-32	6
227	100337-099	O-RING CORD 3/16	FT 3.5
229	68773-002	JUMPER, 2 PIN	4
230	100707-000	INNER STIFFENER	1
231	100708-000	OUTER STIFFENER	1
232	011252-006	SCREW 1/4-20 UNC HHC X 3/4 LG	1
233	011240-004	WASHER 1/4 FLAT	2
234	011248-004	LOCKNUT 1/4-20 UNC	1
235	011248-003	LOCKNUT 10-24 UNC	8

SEENEXTPAGE

## *Upper Control Assembly SB60 Diesel 100016-001*

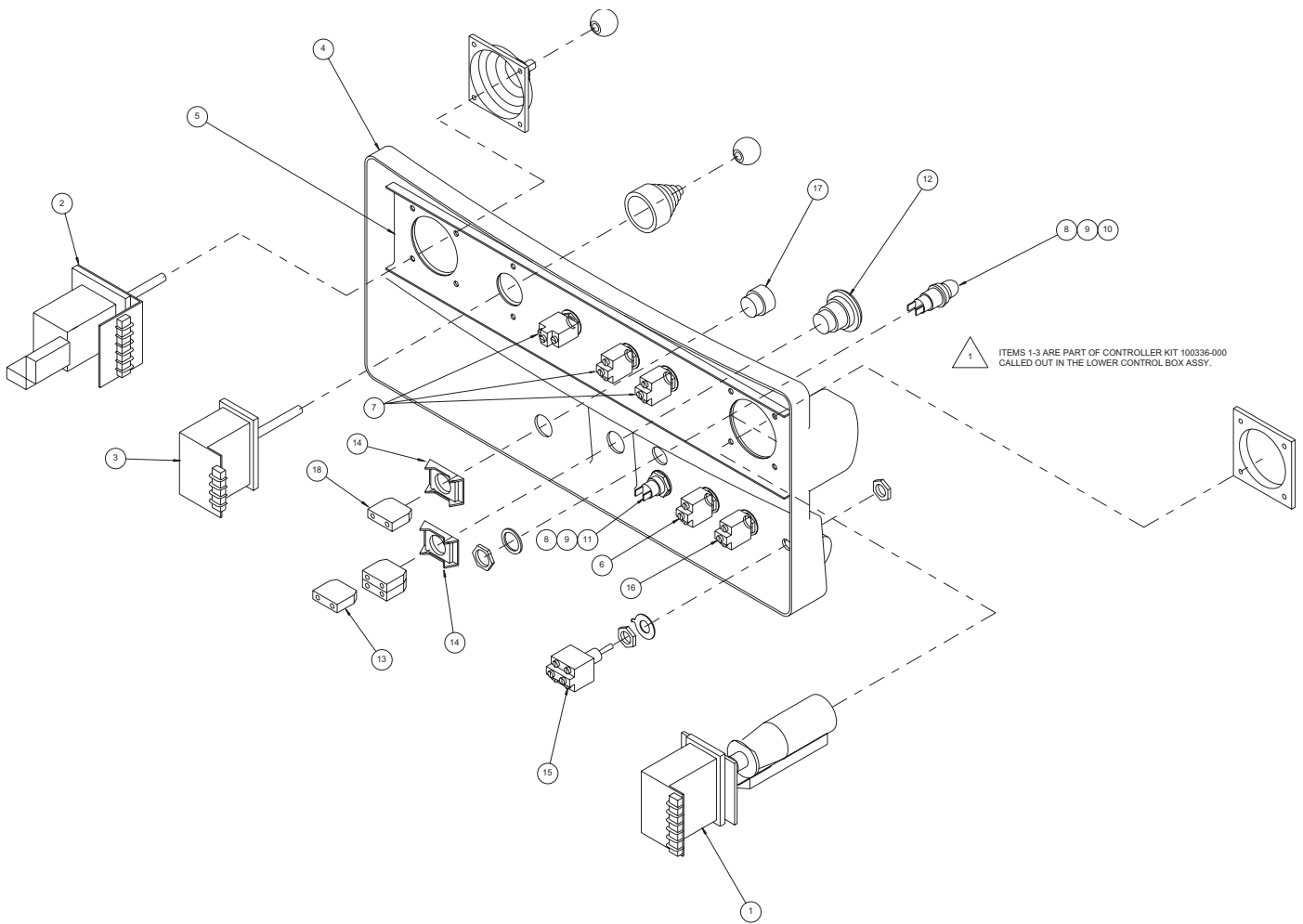
ITEM	PART	DESCRIPTION	QTY.
301	029452-099	WIRE, 16 GA BLACK FT	10
302	029451-099	WIRE, 16 GA WHITE FT	10
303	029454-099	WIRE, 16 GA RED FT	10
304	029457-099	WIRE, 16 GA GREEN FT	10
305	029450-099	WIRE, 16 GA BLUE FT	10
306	029479-099	WIRE, 16 GA WHITE/BLACK FT	10
307	029478-099	WIRE, 16 GA RED/BLACK FT	10
308	005491-099	WIRE, 16 GA GREEN/BLACK FT	10
309	029351-099	WIRE, 06 GA BLACK/WHITE FT	10
310	029352-099	WIRE, 16 GA RED/WHITE FT	10
311	029353-099	WIRE, 16 GA GREEN/WHITE FT	10
312	029354-099	WIRE, 16 GA BLUE/WHITE FT	10
313	029355-099	WIRE, 16 GA BLACK/RED FT	10
314	029358-099	WIRE, 16 GA BLUE/RED FT	10
315	029356-099	WIRE, 16 GA WHITE/RED FT	10
316	029360-099	WIRE, 16 GA ORANGE/GREEN FT	10
317	029456-099	WIRE, 16 GA YELLOW FT	10
318	029477-099	WIRE, 16 GA ORANGE/BLACK FT	10
319	029475-099	WIRE, 16 GA BLUE/BLACK FT	10
320	029359-099	WIRE, 16 GA RED/GREEN FT	10
321	029455-099	WIRE, 16 GA BROWN FT	10
322	029362-099	WIRE, 16 GA RED/BLACK/WHITE FT	10
323	029453-099	WIRE, 16 GA ORANGE FT	10
324	029488-099	WIRE, 16 GA, 6 COND FT	10
325	029461-099	WIRE, 14 GA BLACK FT	10
326	029466-099	WIRE, 14 GA WHITE FT	10
327	029460-099	WIRE, 14 GA RED FT	10
328	029825-002	DIODE, 5 AMP, 400V	15
329	029601-013	CONN, RING 16-14 #10	23
330	029610-002	CONN, FORK 16-14 #8	4
331	029616-002	CONN, FEMALE PUSH 16-14	61
332	029490-099	WIRE 16 GAUGE, 2 COND, TYPE SO FT	5



100016-000

11X17

page to be placed here. This page is FPO

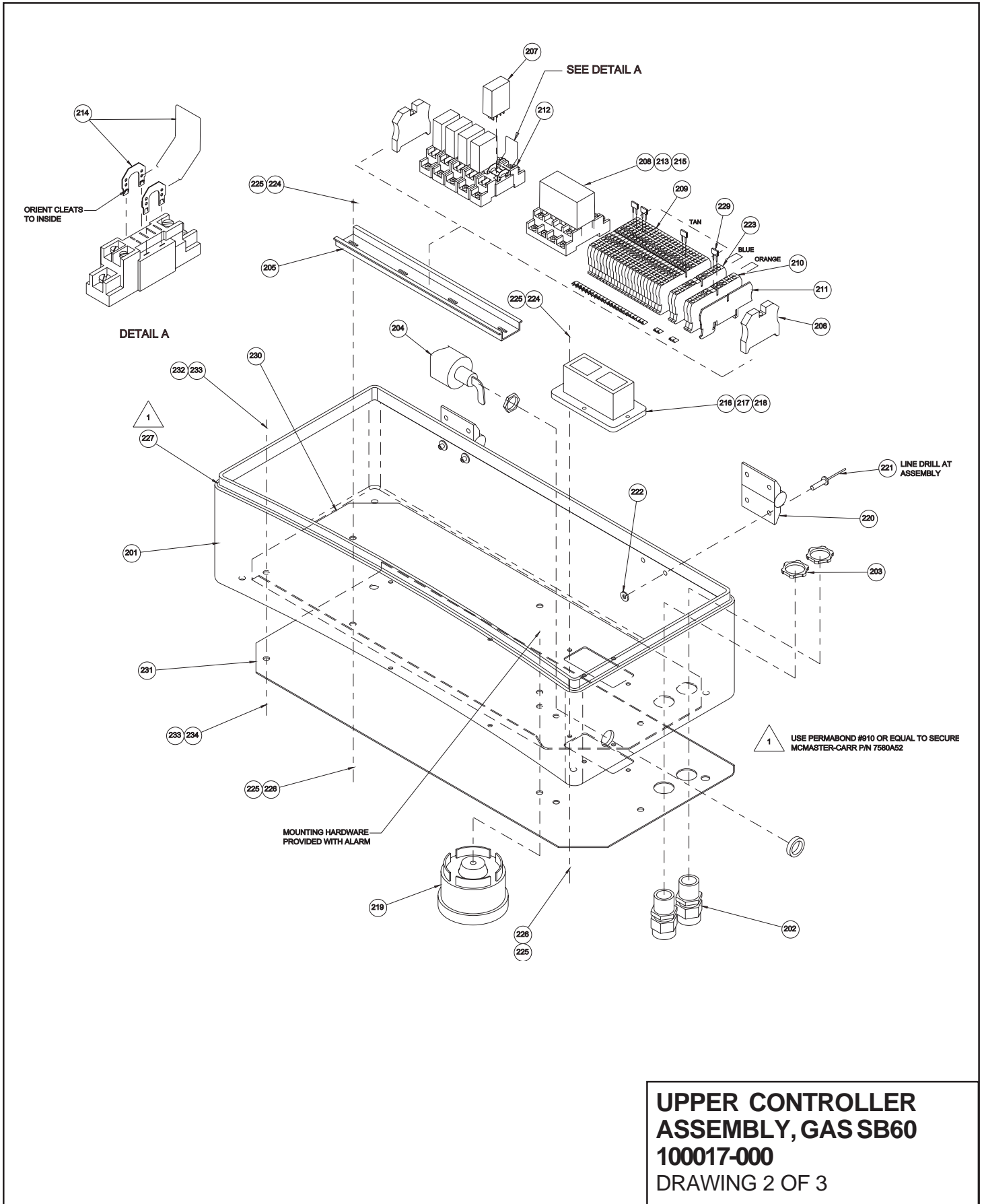


**UPPER CONTROLLER  
ASSEMBLY, GAS, SB60  
100017-000  
DRAWING 1 OF 3**

## *Upper Controller Assembly Gas, SB60 100017-000*

ITEM	PART	DESCRIPTION	QTY.
1	100325-000	DRIVE CONTROLLER	REF
2	100326-000	LIFT CONTROLLER	REF
3	100327-000	EXTEND CONTROLLER	REF
4	100309-000	UPPER CONTROL BOX	1
5	100310-000	STIFFENER, UPPER CONTROLLER	1
6	012797-000	SWITCH TOGGLE SPST MAINTAINED	1
7	012798-000	SWITCH TOGGLE SPDT MOMENTARY	3
8	068590-000	BASE INDICATOR SPDT MOMENTARY	2
9	068591-001	LAMP T-2 1/2	2
10	068595-002	LENS AMBER	1
11	068595-001	LENS RED	1
12	064446-003	EMERGENCY STOP BUTTON	1
13	064443-002	CONTACT BLOCK NC	3
14	064417-001	FLANGE MOUNT	2
15	012798-005	SWITCH TOGGLE DPST MOMENTARY	1
16	029871-001	SWITCH TOGGLE SPDT MAINTAINED	1
17	067654-000	PUSH BUTTON, FLUSH (BLACK)	1
18	064443-001	CONTACT BLOCK NO	1

SEENEXTPAGE



**UPPER CONTROLLER  
ASSEMBLY, GAS SB60  
100017-000  
DRAWING 2 OF 3**

## Upper Controller Assembly Gas, SB60 100017-000

ITEM	PART	DESCRIPTION	QTY.
201	100309-000	UPPER CONTROL BOX	REF
202	029925-002	CONNECTOR CABLE 1/2 NPT	2
203	029939-002	LOCKNUT 1/2 NPT	2
204	100334-000	SWITCH, LEVER	1
205	067893-000	MOUNTING RAIL DIN X 13 LG	1
206	067660-006	TERMINAL END	2
207	067661-001	RELAY SPDT 12VDC	5
208	067661-004	RELAY 4PDT 12VDC	1
209	068698-001	TERMINAL BLOCK (TAN)	23
210	068698-000	TERMINAL BLOCK (ORANGE)	2
211	068698-004	END CAP, CONTACT BLOCK	1
212	067662-001	RELAY SOCKET SPDT	5
213	067662-004	RELAY SOCKET 4PDT	1
214	067662-005	RETAINER CLIP ASSY	5
215	067662-007	RETAINER CLIP ASSY	1
216	015790-006	CONNECTOR RECEPTACLE	1
217	015790-004	PIN CONTACT 16-18G	27
218	015790-007	PIN CONTACT 14-16G	3
219	066807-001	ALARM 107DB	1
220	100319-000	HINGE SOUTH CO C6-30	2
221	026553-004	RIVET PDP 3/16 DIA X .375 GRIP	8
222	011240-002	WASHER #8 FLAT	8
223	068698-002	TERMINAL BLOCK (BLUE)	2
224	011715-006	SCREW RD HD MACHINE #6-32 X 3/4 LG	6
225	011240-001	WASHER #6-32	12
226	011248-047	LOCKNUT #6-32	6
227	100337-099	O-RING CORD 3/16	FT 3.5
229	068773-002	JUMPER, 2 PIN	4
230	100707-000	INNER STIFFENER	1
231	100708-000	OUTER STIFFENER	1
232	011252-006	SCREW 1/4-20 UNC HHC X 3/4 LG	1
233	011240-004	WASHER 1/4 FLAT	2
234	011248-004	LOCKNUT 1/4-20 UNC	1

SEENEXTPAGE

## *Upper Controller Assembly Gas, SB60 100017-000*

ITEM	PART	DESCRIPTION	QTY.
301	029452-099	WIRE, 16 GA BLACK FT	10
302	029451-099	WIRE, 16 GA WHITE FT	10
303	029454-099	WIRE, 16 GA RED FT	10
304	029457-099	WIRE, 16 GA GREEN FT	10
305	029450-099	WIRE, 16 GA BLUE FT	10
306	029479-099	WIRE, 16 GA WHITE/BLACK FT	10
307	029478-099	WIRE, 16 GA RED/BLACK FT	10
308	005491-000	WIRE, 16 GA GREEN/BLACK FT	10
309	029351-099	WIRE, 16 GA BLACK/WHITE FT	10
310	029352-099	WIRE, 16 GA RED/WHITE FT	10
311	029353-099	WIRE, 16 GA GREEN/WHITE FT	10
312	029354-099	WIRE, 16 GA BLUE/WHITE FT	10
313	029355-099	WIRE, 16 GA BLACK/RED FT	10
314	029358-099	WIRE, 16 GA BLUE/RED FT	10
315	029356-099	WIRE, 16 GA WHITE/RED FT	10
316	029360-099	WIRE, 16 GA ORANGE/GREEN FT	10
317	029456-099	WIRE, 16 GA YELLOW FT	10
318	029477-099	WIRE, 16 GA ORANGE/BLACK FT	10
319	029475-099	WIRE, 16 GA BLUE/BLACK FT	10
320	029359-099	WIRE, 16 GA RED/GREEN FT	10
321	029455-099	WIRE, 16 GA BROWN FT	10
322	029362-099	WIRE, 16 GA RED/BLACK/WHITE FT	10
323	029453-099	WIRE, 16 GA ORANGE FT	10
324	029488-099	WIRE, 16 GA, 6 COND FT	11
325	029461-099	WIRE, 14 GA BLACK FT	10
326	029466-099	WIRE, 14 GA WHITE FT	10
327	029460-099	WIRE, 14 GA RED FT	10
328	029825-002	DIODE, 5 AMP, 400V	15
329	029601-013	CONN, RING 16-14 #10	23
330	029610-006	CONN, FORK 16-14 #6	59
331	029616-002	CONN, FEMALE PUSH 16-14	4
332	029490-099	WIRE 16 GAUGE, 2 COND, TYPE SO FT	5

100017-000

11X17

page to be placed here. This page is FPO

## *Engine Module Assembly Diesel 100012-000*

ITEM	PART	DESCRIPTION	QTY.
201	100338-000	CONNECTOR, MALE (21 PIN)	1
202	100338-005	BOOT	1
205	100338-012	CONTACT, 12 GA SOCKET	3
207	100338-014	CONTACT, 16 GA SOCKET	15
209	068764-000	PLUG, SEALING	3
210	029480-099	WIRE, 10 GA RED FT	6
211	029484-099	WIRE, 8 GA RED FT	6
212	029452-099	WIRE, 16 GA BLACK FT	6
213	029451-099	WIRE, 16 GA WHITE FT	6
214	029454-099	WIRE, 16 GA RED FT	6
215	029457-099	WIRE, 16 GA GREEN FT	6
216	029453-099	WIRE, 16 GA ORANGE FT	6
217	029450-099	WIRE, 16 GA BLUE FT	6
218	029479-099	WIRE, 16 GA WHITE/BLACK FT	6
219	029478-099	WIRE, 16 GA RED/BLACK FT	6
220	005491-099	WIRE, 16 GA GREEN/BLACK FT	6
221	029477-099	WIRE, 16 GA ORANGE/BLACK FT	6
222	029475-099	WIRE, 16 GA BLUE/BLACK FT	6
223	029351-099	WIRE, 16 GA BLACK/WHITE FT	6
224	029352-099	WIRE, 16 GA RED/WHITE FT	6
225	029353-099	WIRE, 16 GA GREEN/WHITE FT	6
226	029354-099	WIRE, 16 GA BLUE/WHITE FT	6
227	029470-099	WIRE, 12 GA RED FT	6
228	064195-080	BATTERY CABLE ASSY X80LG	1
229	064195-050	BATTERY CABLE ASSY X50LG	1
230	029931-003	CONN FEM PUSH (.25) 16-14 GA	7
231	029617-002	CONN MALE PUSH (.25) 16-14 GA	6
232	029601-039	CONN RING TERM 0-5/16 12-10 GA	8
233	029601-012	CONN RING TERM. #8 0 16-14 GA	2
234	029620-003	CONNECTOR, BUTT 10-12 GA	3
235	029610-006	CONN FORK TERM #8 0 14-16 GA	4
236	029825-002	DIODE, 5 AMP	1
237	014435-001	BATTERY TERMINAL	2
238	029601-025	CONN RING TERM 0 5/16 8 GA	4
239	064195-032	BATTERY CABLE ASSY X32LG	1
240	029419-099	WIRE, 12 GA RED. GRN	6
241	029418-099	WIRE, 12 GA RED/BLK	12



100012-000

11X17

page to be placed here. This page is FPO

## Engine Module Assembly

### Gas

### 100013-000

ITEM	PART	DESCRIPTION	QTY.
201	100338-000	CONNECTOR, MALE (21 PIN)	1
202	100338-005	BOOT	1
205	100338-012	CONTACT, 12 GA SOCKET	3
207	100338-014	CONTACT, 16 GA SOCKET	15
208	029484-099	WIRE, 8 GA RED	FT 6
209	068764-000	PLUG, SEALING	3
210	067990-002	LOCKING WEDGE, MALE	1
211	067990-003	LOCKING WEDGE, FEMALE	1
212	029452-099	WIRE, 16 GA. BLACK	FT 6
213	029451-099	WIRE, 16 GA WHITE	FT 6
214	029454-099	WIRE, 16 GA RED	FT 6
215	029456-099	WIRE, 16 GA YELLOW	FT 6
216	029453-099	WIRE, 16 GA ORANGE	FT 6
217	029450-099	WIRE, 16 GA BLUE	FT 6
218	029479-099	WIRE, 16 GA WHITE/BLACK	FT 6
219	029472-099	WIRE, 12 GA BLACK	FT 12
220	005491-099	WIRE, 16 GA GREEN/BLACK	FT 6
221	029477-099	WIRE, 16 GA ORANGE/BLACK	FT 6
222	029475-099	WIRE, 16 GA BLUE/BLACK	FT 6
223	029351-099	WIRE, 16 GA BLACK/WHITE	FT 6
224	029352-099	WIRE, 16 GA RED/WHITE	FT 6
225	029353-099	WIRE, 16 GA GREEN/WHITE	FT 6
226	029354-099	WIRE, 16 GA BLUE/WHITE	FT 6
227	029470-099	WIRE, 12 GA RED	FT 18
228	064195-080	BATTERY CABLE ASSY X80LG	2
229	064195-032	BATTERY CABLE ASSY X32LG	1
230	029931-003	CONN. FEM PUSH (.25) 16-14 GA	7
231	029617-002	CONN. MALE PUSH (.25) 16-14 GA	6
232	029601-039	CONN. RING TERM. 0-5/16 12-10 GA	6
233	029601-012	CONN. RING TERM. #8 0-16-14 GA	1
234	029620-003	CONNECTOR, BUTT 10-12 GA	4
235	029610-006	CONN. FORK TERM, #8 0-14-16 GA	18
236	029825-002	DIODE	1
237	014435-001	BATTERY TERMINAL	2
238	029616-003	CONN. FEMALE PUSH 12-10	3
239	029419-099	WIRE, 12 GA RED/GRN	6
240	029418-099	WIRE, 12 GA RED/BLK	12
241	029601-025	CONN. RING TERM 0-5/16 8 GA	4

100013-000

11X17

page to be placed here. This page is FPO



## 6.0 Introduction

This section lists and illustrates the replaceable assemblies and parts of the SB60 Work Platform, as manufactured by UpRight, Inc.

Each parts list contains the component parts for that assembly indented to show relationship where applicable.

## 6.1 Index

ASSEMBLY	PAGE	ASSEMBLY	PAGE
<b>FINAL ASSEMBLY, DIESEL</b>		<b>HYDRAULIC RESERVOIR ASSEMBLY</b>	
100000-000 .....	6-2	100271-000 .....	6-59
<b>FINAL ASSEMBLY, GAS</b>		<b>DIFFERENTIAL LOCK-VALVE BLOCK ASSEMBLY</b>	
100001-000 .....	6-6	100317-000 .....	6-60
<b>BASIC ASSEMBLY</b>		<b>BRAKE, AXLE LOCK, 2 SPEED-VALVE BLOCK ASSEMBLY</b>	
100004-000 Gas .....	6-10	100323-000 .....	6-61
100004-001 Diesel .....	6-10	<b>FRONT DRIVE CHECK VALVES-VALVE BLOCK ASSEMBLY</b>	
<b>CHASSIS ASSEMBLY</b>		100716-000 .....	6-62
100008-000 .....	6-12	<b>REAR DRIVE CHECK VALVES-VALVE BLOCK ASSEMBLY</b>	
<b>TURRET ASSEMBLY</b>		100717-000 .....	6-62
100010-000 .....	6-14	<b>JIB BOOM-VALVE BLOCK ASSEMBLY</b>	
<b>MAIN BOOM ASSEMBLY</b>		100283-001 .....	6-63
100009-000 .....	6-16	<b>ROTARY MANIFOLD ASSEMBLY</b>	
<b>JIB BOOM ASSEMBLY</b>		100190-000 .....	6-64
100011-000 .....	6-18	<b>MOTION CONTROL - MASTER CYLINDER-VALVE BLOCK ASSEMBLY</b>	
<b>FRONT AXLE ASSEMBLY</b>		100269-001 .....	6-66
100060-000 .....	6-20	<b>MOTION CONTROL - PLATFORM ROTATE - VALVE BLOCK ASSEMBLY</b>	
<b>ENGINE MODULE ASSEMBLY</b>		100269-002 .....	6-67
100012-000 Diesel .....	6-22	<b>LABEL KIT</b>	
<b>ENGINE MODULE ASSEMBLY</b>		100024-000 Diesel .....	6-68
100013-000 Gas .....	6-26	100024-001 Gas .....	6-68
<b>CONTROL MODULE ASSEMBLY</b>		<b>TIRE &amp; WHEEL ASSEMBLY</b>	
100014-000 Gas .....	6-30	100090-000 Left Hand .....	6-70
100014-001 Diesel .....	6-30	100090-001 Right Hand .....	6-70
<b>CHASSIS HOSE KIT</b>		<b>SIX FOOT CAGE ASSEMBLY</b>	
100421-000 .....	6-32	100417-000 .....	6-71
<b>TURRET HOSE KIT</b>		<b>EIGHT FOOT CAGE OPTION</b>	
100421-000 .....	6-34	100417-001 .....	6-72
<b>BOOM HOSE KIT</b>		<b>DUAL FUEL INSTALLATION OPTION</b>	
100421-000 .....	6-36	100227-000 .....	6-74
<b>UPPER CONTROLLER ASSEMBLY, DIESEL</b>		<b>MOTION ALARM OPTION</b>	
100016-001 .....	6-38	100096-000 .....	6-78
<b>UPPER CONTROLLER ASSEMBLY, GAS</b>		<b>FLASHING BEACON OPTION</b>	
100017-000 .....	6-42	100097-000 .....	6-79
<b>LOWER CONTROLLER ASSEMBLY, DIESEL</b>		<b>GENERATOR OPTION, GAS</b>	
100018-000 .....	6-46	100098-000 .....	6-80
<b>LOWER CONTROLLER ASSEMBLY, GAS</b>		<b>GENERATOR OPTION, DIESEL</b>	
100019-000 .....	6-50	100098-001 .....	6-82
<b>COVER INSTALLATION</b>		<b>CORD ASSEMBLY - GENERATOR OPTION</b>	
100308-000 .....	6-54	100705-000 .....	6-84
<b>MAIN VALVE BLOCK ASSEMBLY</b>		<b>HOSE KIT - GENERATOR OPTION</b>	
100264-00 .....	6-56	100447-000 .....	6-85
<b>FUEL TANK ASSEMBLY</b>			
100270-000 Diesel .....	6-58		
<b>FUEL TANK ASSEMBLY</b>			
100270-001 Gas .....	6-58		

# Illustrated Parts Breakdown

## FINAL ASSEMBLY, DIESEL SB60

100000-000

ITEM	PART	DESCRIPTION	QTY.
1	100004-001	BASICASSEMBLY SB-60DSL	1
2	100308-000	COVER INSTALLATION	1
3	011252-006	SCREW HHC GRS 1/4-20 UNC X 3/4	7
4	014996-004	WASHER 1/4 SAE FLAT PLTO	7
5	011248-004	NUT HEX ESNA 1/4-20 UNC	11
6	100417-000	PLATFORM (6 FT)	1
7	100016-001	UPPER CONTROL BOX ASSY - DSL	1
11	100024-000	LABEL KIT - DIESEL	1
12	029945-018	LEVEL SENSOR	1
13	100320-099	CONTROL CABLE, 3-12 GA	FT75
15	100026-004	ELECTRICAL SCHEMATIC	REF
16	100027-000	HYDRAULIC SCHEMATIC	REF
19	020032-001	FITTING AERO 2033-4-4S	2
20	100436-001	FITTING AERO FF 1898T-0404S	1
22	020032-004	FITTING AERO 2033-8-85	1
27	068820-000	RETAINING STRAP-FOOTSWITCH	2
28	063906-000	FOOT SWITCH CLPR	1
29	064479-000	SWITCH GUARD, FOOT	1
30	011252-012	SCREW HHC 1/4-20 UNC X 1-1/2	4
31	066695-006	SCREW FLAT HD 10-24 UNC X 3/4	2
32	013949-003	WASHER, #10 STAR, EXTERNAL TOOTH	2
33	011250-003	HEX NUT 10-24 UNC	2
35	014693-002	FITTINGS, STR 4MJ-8FJ	1
36	020733-003	FITTING, TEE 8MJ-8FJX-8MJ	1
201	015790-005	CONNECTOR, DEUTSCH PLUG	1
202	015790-003	SOCKET, CONTACT 16-18	29
203	015790-008	SOCKET, CONTACT 14-16	3
204	015790-009	BOOT, DEUTSCH PLUG	1
205	029496-099	CABLE, 2 COND/16 GA.	21
206	100338-011	CONN, 12 GA PIN	1
208	064195-010	BATTERY CABLE ASSY X10	2
209	064195-019	BATTERY CABLE ASSY X19	1
210	029470-099	WIRE 12 GA RED	8
211	029601-039	CONN RING 10-12	1
212	029617-003	CONN M PUSH 10-12	1
213	029601-005	CONN RING 18-22 GA #10	2

### SPECIFICATIONS AND ADJUSTMENTS

#### HYDRAULIC PRESSURE:

##### COUNTERBALANCE VALVES; (VALVES PRESET)

LIFT	3000 PSI	
SWING	1000 PSI	LEFT AND RIGHT
EXTEND	1500 PSI	
RETRACT	3000 PSI	
LEVEL SYSTEM	PSI	3000 MASTER AND SLAVE 1500
JIB	PSI	JIB UP 3000 - JIB DOWN 1000
AXLE LOCK	3000 PSI	
PLATFORM ROTATE	1000 PSI	(MAY DEVIATE TO PREVENT CHATTER)

##### RELIEF VALVES;

MAIN PRESSURE	2700 PSI	
STEER CROSSOVERS	2700 PSI	BOTH DIRECTIONS
BOOM LOWERING	1450 PSI	
SWING SYSTEM	1000 PSI	
EXTEND, HIGH	2200 PSI	
EXTEND, LOW	1750 PSI	
JIB LOWER	1400 PSI	
PLATFORM ROTATOR	2000 PSI	BOTH DIRECTIONS

##### DRIVE SYSTEM;

PUMP RE		
CHARGE PRESSURE	450 PSI	
DRAW BAR PULL	9000 LBS MIN.	

#### SUPERFLEX PRESETS:

FUNCTION	MAX	THRESHOLD	RAMP ON	RAMP OFF
EXTEND	95%	40%	0.5	0.2
RETRACT	95%	40%	0.5	0.2
LIFT, UP	95%	34.5%	0.5	0.2
LIFT, DOWN	95%	28%	0.5	0.2
SWING, LEFT/RIGHT	80%	32.5%	0.5	0.5
DRIVE, FWD./REV.	65%	28%	0.8	0.8
DUAL RANGE	33%			

STOPPING DISTANCE NOT TO EXCEED 6.5 FEET

#### ADJUSTMENTS TO BE MADE FROM THESE PRESETS BASED ON SPEED MEASUREMENTS.

#### SPEED MEASUREMENTS:

BOOM FUNCTIONS LIFT AND EXTEND OPERATED SIMULTANEOUSLY  
ELEVATING TO FULL HEIGHT AND RETURNING TO STOWED POSITION.  
FULL CYCLE TIME: 115-135 SEC.  
HALF CYCLE, UP 60-70 SEC.  
HALF CYCLE DOWN: 55-65 SEC.

#### BOOM FUNCTIONS OPERATED INDIVIDUALLY.

EXTEND: 55-65 SEC.  
RETRACT: 30-45 SEC.  
LIFT: 60-65 SEC.  
LOWER: 50-60 SEC.

#### TURNTABLE (TURRET) ROTATE:

FULL 360° ROTATION; 90 SEC. FULL 360±5 SEC.

#### JIB UP/DOWN:

40/30 SEC. ±5 SEC.  
FLOW CONTROL ON MAIN VALVE BLOCK.

#### PLATFORM ROTATE:

16 SEC. ±2 SEC.  
FULL 180° ROTATION  
FLOW CONTROL ON VALVE BLOCK IN JIB BOOM.

#### STEER:

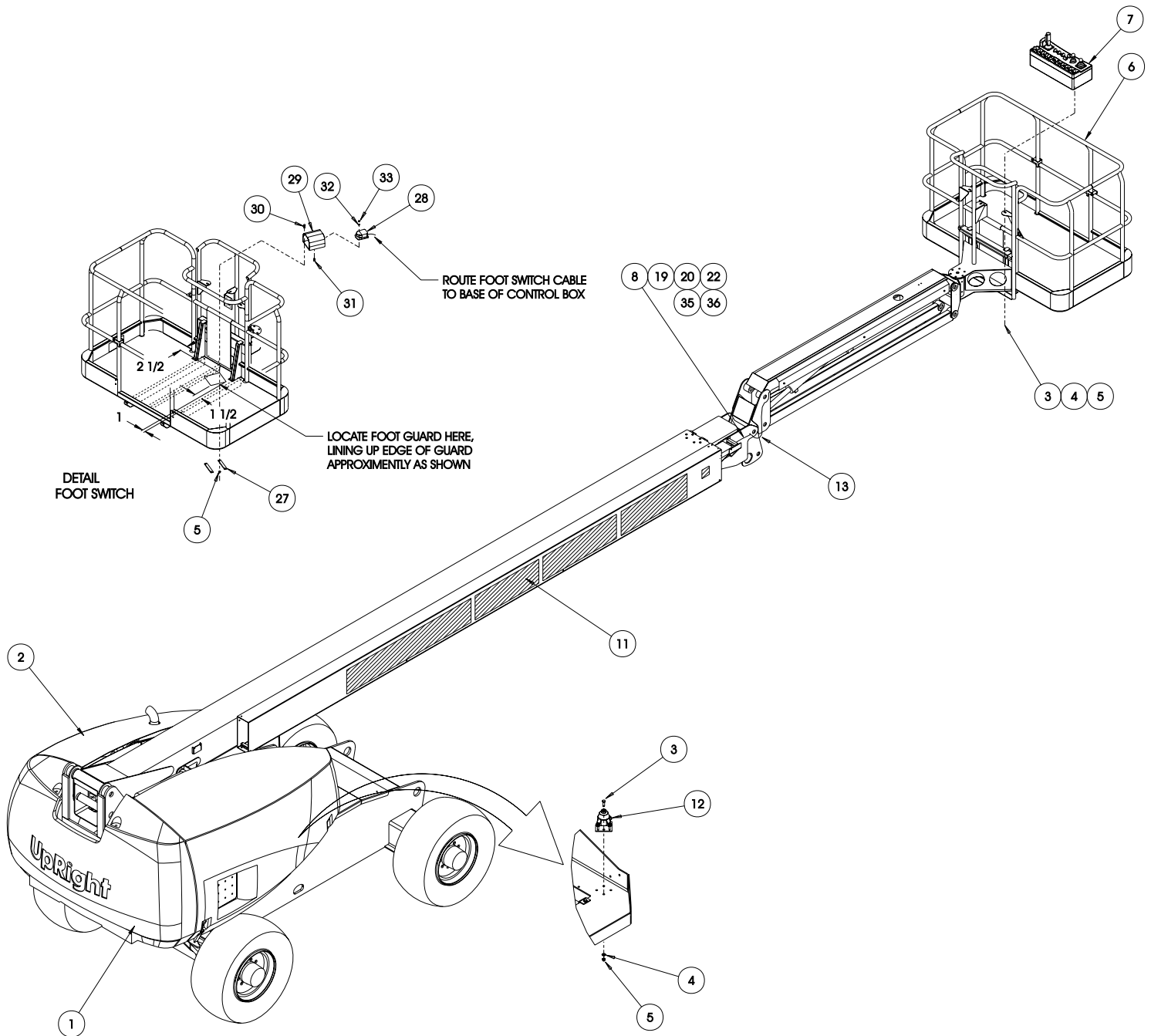
LOCK TO LOCK 7 SEC. ±1 SEC.

#### DRIVE SPEEDS:

	SPEED	20 FT. TIME
HIGH SPEED	3.8 TO 4.2 MPH	3.6 TO 3.2 SEC.
LOW SPEED	0.5 TO 0.7 MPH	27.3 TO 19.5 SEC.

# Illustrated Parts Breakdown

Section  
**6.2**



**FINAL ASSEMBLY,  
DIESEL, SB60  
100000-000  
DRAWING 1 OF 2**





**NOTES:**

# Illustrated Parts Breakdown

## FINAL ASSEMBLY, GAS SB60

100001-000

ITEM	PART	DESCRIPTION	QTY.
1	100004-000	BASICASSEMBLY SB-60 GAS	1
2	100308-000	COVER INSTALLATION	1
3	011252-006	SCREW HHC GRS 1/4-20 UNC X 3/4	7
4	014996-004	WASHER 1/4 SAE FLAT PLTD	7
5	011248-004	NUT HEX ESNA 1/4-20 UNC	7
6	100417-000	PLATFORM(6 FT)	1
7	100017-000	UPPER CONTROL BOX ASSY-GAS	1
8	100421-000	HOSE KIT	1
11	100024-001	LABEL KIT-GAS DOM.	1
12	029945-018	LEVEL SENSOR	1
13	100320-099	CONTROL CABLE, 3-12 GA	FT 75
15	100026-000	ELECTRICAL SCHEMATIC	REF
16	100027-000	HYDRAULIC SCHEMATIC	REF
19	020032-001	FITTING AERO 2033-4-4S	2
20	100436-001	FITTING AERO FF1898T-0404S	1
22	020032-004	FITTING AERO 2033-8-8S	1
27	068820-000	RETAINING STRAP-FOOTSWITCH	2
28	063906-000	FOOT SWITCH CLPR	1
29	064479-000	SWITCH GUARD, FOOT	1
30	011252-012	SCREW HHC 1/4-20 UNC X 1-1/2	4
31	066695-006	SCREW FLAT HD 10-24 UNC X 3/4	2
32	013949-003	WASHER, #10 STAR, EXTERNAL TOOTH	2
33	011250-003	HEX NUT 10-24 UNC	2
35	014693-002	FITTING, STR 4MJ-8FJ	1
36	020733-003	FITTING, TEE 8MJ-8FJX-8MJ	1
201	015790-005	CONNECTOR, DEUTSCH PLUG	1
202	015790-003	SOCKET, CONTACT 16-18	29
203	015790-008	SOCKET, CONTACT 14-16	3
204	015790-009	BOOT, DEUTSCH PLUG	1
205	029496-099	CABLE, 2 COND/16 GA	FT 21
206	100338-011	CONN, 12 GA PIN	1
208	064195-010	BATTERY CABLE ASSY X10	2
209	064195-019	BATTERY CABLE ASSY X19	1
210	029470-099	WIRE 12 GA RED	FT 8
211	029601-039	CONN RING 10-12	1
212	029617-003	CONN M PUSH 10-12	1
213	029601-005	CONN RING 18-22 GA #10	2

### SPECIFICATIONS AND ADJUSTMENTS

#### HYDRAULIC PRESSURE:

##### COUNTERBALANCE VALVES; (VALVES PRESET)

LIFT 3000 PSI  
 SWING 1000 PSI LEFT AND RIGHT  
 EXTEND 1600 PSI  
 RETRACT 3000 PSI  
 LEVEL SYSTEM PSI 3000 MASTER AND SLAVE 1600  
 JIB PSI JIB UP 8000 - JIB DOWN 1000  
 AXLE LOCK 3000 PSI  
 PLATFORM ROTATE 1000 PSI

##### RELIEF VALVES;

MAIN PRESSURE 2700 PSI  
 STEER CROSSOVERS 2700 PSI BOTH DIRECTIONS  
 BOOM LOWERING 1480 PSI  
 SWING SYSTEM 1000 PSI  
 EXTEND, HIGH 2200 PSI  
 EXTEND, LOW 1760 PSI  
 JIB LOWER 1400 PSI  
 PLATFORM ROTATOR 2000 PSI BOTH DIRECTIONS

##### DRIVE SYSTEM;

PUMP RELIEFS 5000 PSI  
 CHARGE PRESSURE 450 PSI  
 DRAW BAR PULL 9000 LBS MIN.

#### SUPERFLEX PRESETS:

FUNCTION	MAX	THRESHOLD	RAMP ON	RAMP OFF
EXTEND	95%	40%	0.5	0.2
RETRACT	95%	40%	0.5	0.2
LIFT, UP	95%	34.5%	0.5	0.2
LIFT, DOWN	95%	28%	0.5	0.2
SWING, LEFT/RIGHT	80%	32.5%	0.5	0.5
DRIVE, FWD./REV.	65%	28%	0.8	0.8
DUAL RANGE	33%			

#### ADJUSTMENTS TO BE MADE FROM THESE PRESETS BASED ON SPEED MEASUREMENTS.

#### SPEED MEASUREMENTS:

BOOM FUNCTIONS LIFT AND EXTEND OPERATED SIMULTANEOUSLY  
 ELEVATING TO FULL HEIGHT AND RETURNING TO STOWED POSITION.  
 FULL CYCLE TIME: 11.8-13.6 SEC.  
 HALF CYCLE, UP 60-70 SEC.  
 HALF CYCLE DOWN: 55-65 SEC.

#### BOOM FUNCTIONS OPERATED INDIVIDUALLY.

EXTEND: 55-65 SEC.  
 RETRACT: 30-45 SEC.  
 LIFT: 60-65 SEC.  
 LOWER: 80-90 SEC.

#### TURNTABLE (TURRET) ROTATE:

FULL 360° ROTATION; 90 SEC. FULL 360±5 SEC.

#### JIB UP/DOWN:

40/30 SEC. ±5 SEC.  
 FLOW CONTROL ON MAIN VALVE BLOCK.

#### PLATFORM ROTATE:

16 SEC. ±2 SEC.  
 FULL 180° ROTATION  
 FLOW CONTROL ON VALVE BLOCK IN JIB BOOM.

#### STEER:

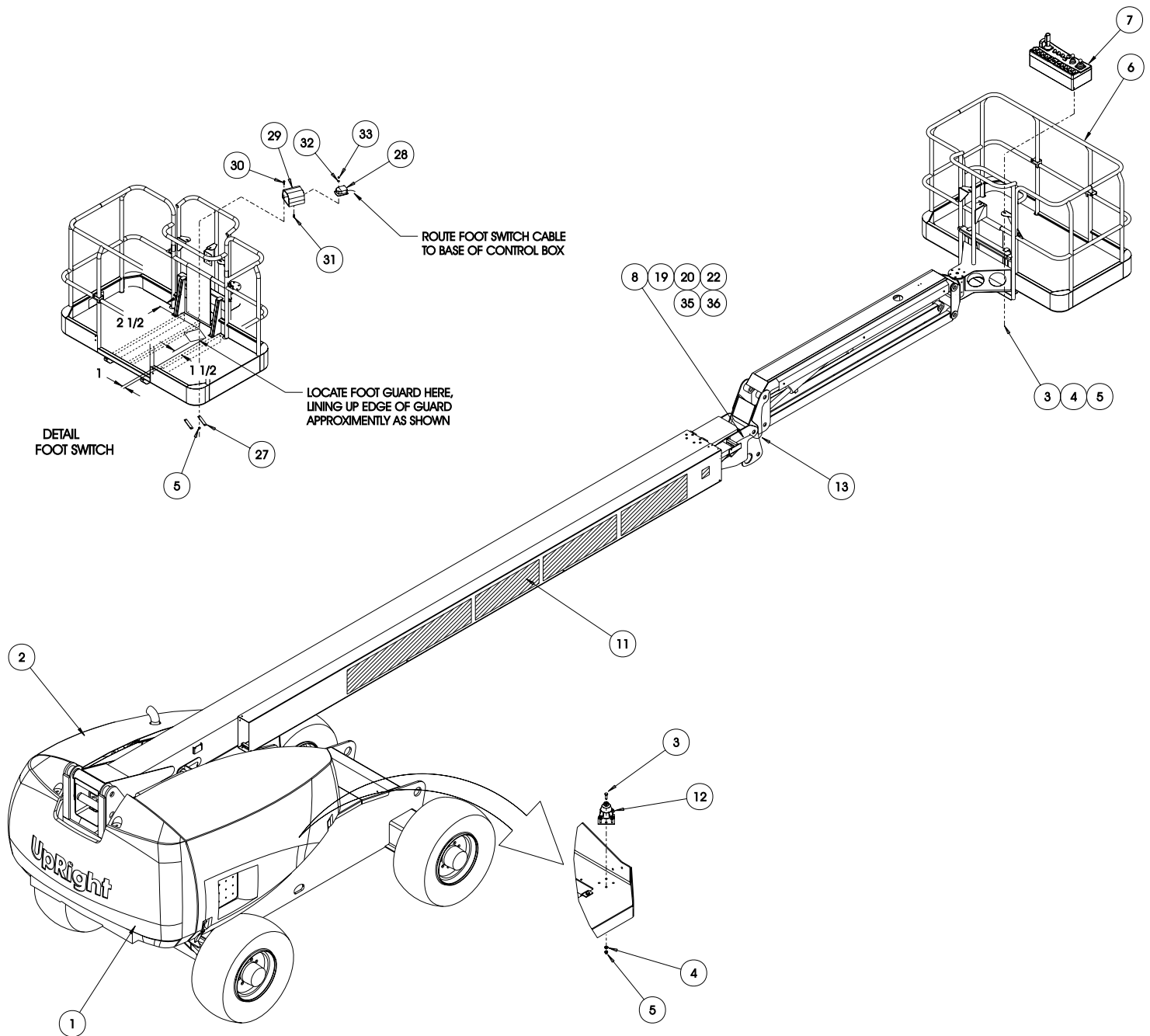
LOCK TO LOCK 7 SEC. ±1 SEC.

#### DRIVE SPEEDS:

SPEED	20 FT. TIME
HIGH SPEED	3.8 TO 4.2 MPH 3.6 TO 3.2 SEC.
LOW SPEED	0.6 TO 0.7 MPH 27.3 TO 19.6 SEC.

# Illustrated Parts Breakdown

Section  
**6.2**



**FINAL ASSEMBLY,  
GAS SB60  
100001-000  
DRAWING 1 OF 2**



**NOTES:**

# Illustrated Parts Breakdown

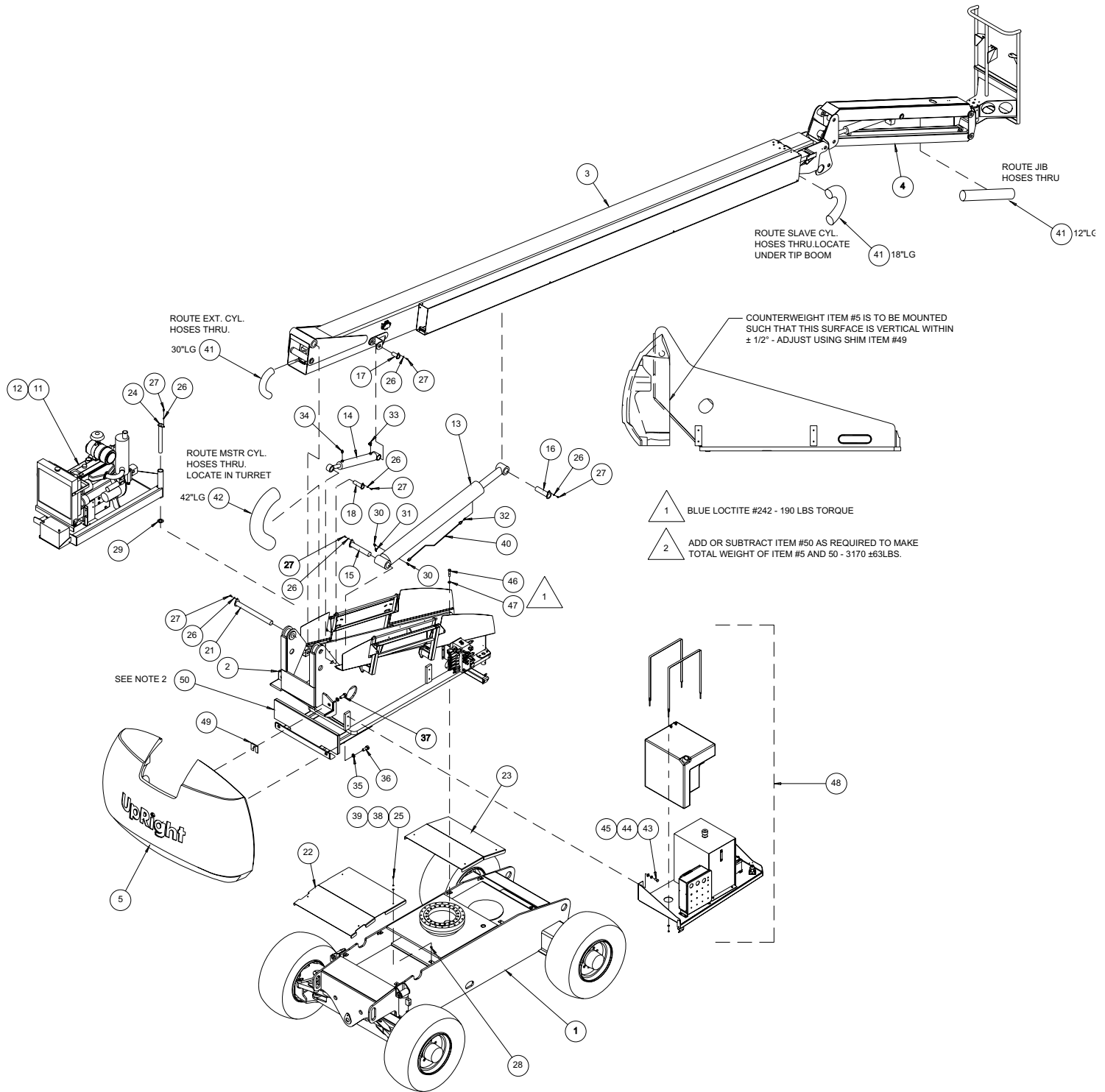
## BASIC ASSEMBLY, SB60

100004-000-GAS

100004-001-DIESEL

ITEM	PART	DESCRIPTION	QTY.
1	100008-000	CHASSISASSEMBLY	1
2	100010-000	TURRETASSEMBLY	1
3	100009-000	LIFTBOOMASSEMBLY	1
4	100011-000	JIBBOOMASSEMBLY/INSTALLATION	1
5	100120-000	COUNTERWEIGHT	1
11	100013-000	ENGINE MODULE ASSY, (GAS)	1
12	100012-000	ENGINE MODULE ASSY, (DSL)	1
13	100555-000	LIFT CYLINDER	1
*	100555-010	SEALKIT	1
14	100553-000	MASTERCYLINDER	1
*	100553-010	SEALKIT	1
15	100474-002	PIN, (LIFT CYL. BASE END)	1
16	100474-001	PIN, (LIFT CYL. ROD END)	1
17	100472-002	PIN, (MASTERCYL. BASE END)	1
18	100472-001	PIN, (MASTERCYL. ROD END)	1
21	100474-000	PIN, (BOOM PIVOT)	1
22	100054-000	COVER, CHASSISFRONT	1
23	100055-000	COVER, CHASSISREAR	1
24	100472-010	PIN, ENGINE MODULE	1
25	011254-004	SCREW, HHC 3/8-16 UNC X 1/2	8
26	011238-006	WASHER, SPLIT LOCK 3/8	6
27	011254-007	SCREW, HHC GRS 3/8-16 UNC X 7/8 LG	6
28	014252-006	NUT-SERT 3/8-16 UNC.	3
29	010092-011	THRUST WASHER	3
30	011934-004	FITTING, 90° 6MB-6MJ	2
31	020733-002	FITTING, TEE 6FJ-6MJ-6MJ	1
32	011941-005	FITTING, STR. 6MB-6MJ	1
33	011934-001	FITTING, 90° 4MB-4MJ	1
34	011941-001	FITTING, STR. 4MB-4MJ	1
35	011238-016	WASHER, SPLIT LOCK 1" DIA	4
36	014918-024	SCREW, HHC 1-8 UNC X 3"	2
37	014918-032	SCREW, HHC 1-8 UNC X 4"	2
38	014996-006	WASHER 3/8" DIA. FLAT	8
39	011240-006	WASHER, FLAT STD 3/8	8
40	100561-000	HYD. TUBE, LIFT CYLINDER	1
41	065396-099	HOSE GUARD (1.42 ID)	FT 5
42	100385-099	HOSE GUARD (2.88 ID)	FT 3.5
43	011257-012	SCREW, HHC 5/8-11 UNC X 1-1/2	4
44	011238-010	WASHER SPLIT LOCK 5/8	4
45	014996-010	WASHER 5/8 SAE FLAT PLTD	4
46	011291-024	SCREW, HHC GR 5/8-11 UNC X 3" LG	20
47	100191-010	WASHER, 5/8 DIA. ASTM A-525	20
48	100014-000	CONTROL MODULE ASSY, (GAS)	1
	100014-001	CONTROL MODULE ASSY, (DSL)	1
49	100198-000	SHIM-COUNTERWEIGHT	4
50	019930-252	BALLAST PLATE	1

# Illustrated Parts Breakdown



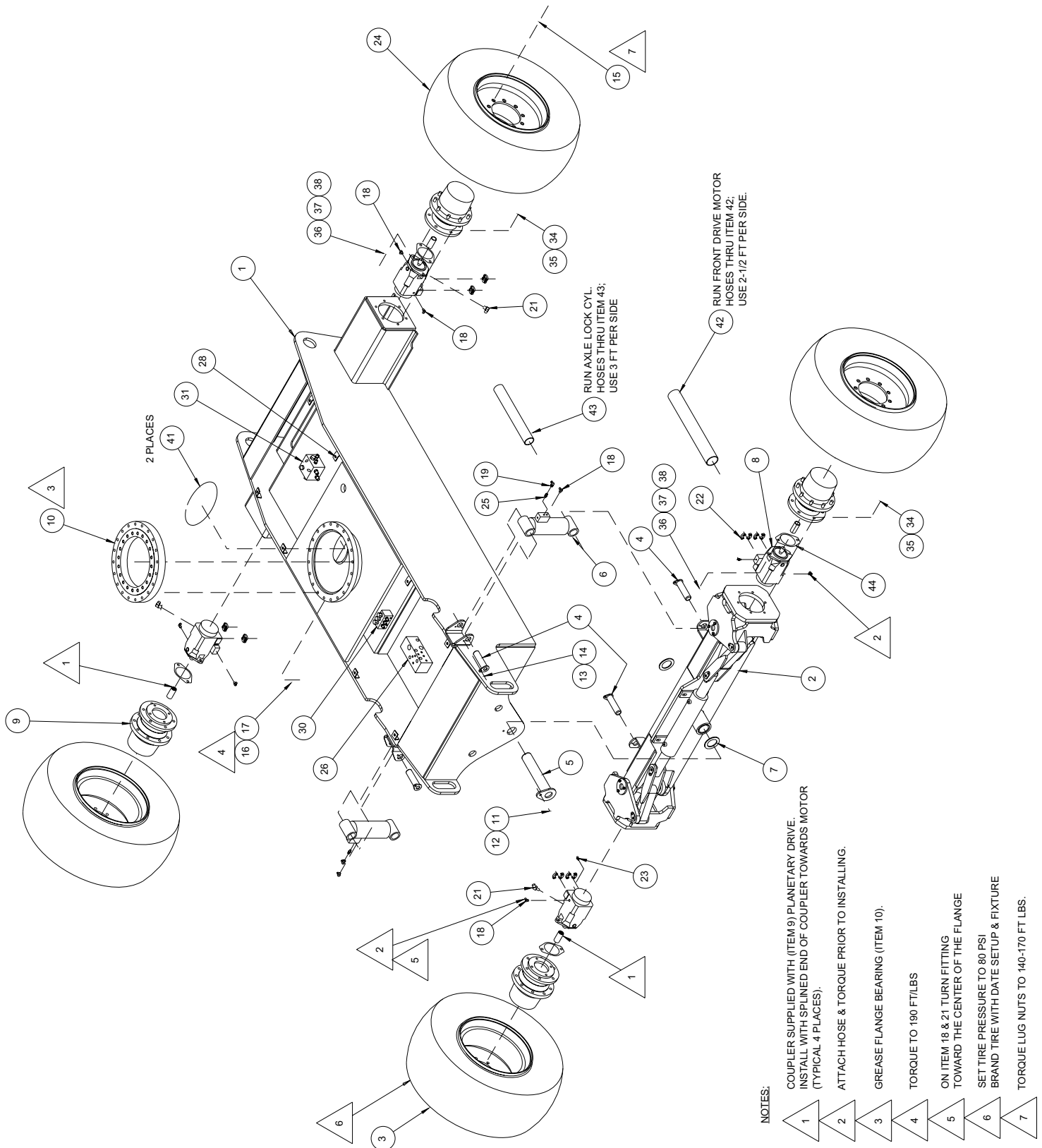
## CHASSIS ASSEMBLY, SB60

100008-000

ITEM	PART	DESCRIPTION	QTY.
1	100030-000	WELDMENT, CHASSIS	1
2	100060-000	ASSEMBLY, STEERING AXLE	1
3	100090-001	ASSEMBLY, TIRE & WHEEL RH	2
4	100472-009	PIN, BOOM PIVOT	4
5	100473-000	PIN, BOOM PIVOT	1
6	100556-000	AXLE LOCK CYLINDER	2
*	100556-010	SEAL KIT	1
7	100563-000	THRUST WASHER 2-1/2 IN ID	2
8	100249-000	DRIVE MOTOR	4
*	100249-010	SEAL KIT	1
9	100254-000	DRIVE HUB	4
*	100254-010	SEAL KIT W/BEARING	1
*	100254-020	SERVICE KIT	1
10	100244-000	SLEW BEARING	1
11	011256-010	SCREW 1/2-13 UNC HHC X 1-1/4 LG	1
12	011238-008	WASHER SPLIT LOCK 1/2	1
13	011254-004	SCREW 3/8-16 UNC HHC X 1/2 LG	4
14	011238-006	WASHER SPLIT LOCK 3/8	4
15	011469-006	LUG NUT 5/8-11 UNF	36
16	011291-020	SCREW 5/8-11 UNF HHC GR 8 X 2-1/2 LG	20
17	011239-010	WASHER FLAT ASTM A325 5/8	20
18	100434-002	FITTING 4MFFOR-4MB 90°	6
19	011937-001	FITTING 4FJX-4MJ 90°	4
21	011935-005	FITTING 10MB-8MJ 45°	4
22	068812-000	FLANGE KIT 12SF XO	8
23	100433-001	FITTING 4MFFOR-4MB 45°	2
24	100090-000	ASSEMBLY, TIRE & WHEEL LH	2
25	011941-001	FITTING, STR. 4MB-4MJ	2
26	100317-000	VALVE BLOCK ASSY, DIFF FLOC	1
28	014252-006	NUT SERT 3/8-16 UNC	8
30	100716-000	VALVE BLOCK ASSY, FRONT DRIVE CHECKS	1
31	100717-000	VALVE BLOCK ASSY, REAR DRIVE CHECKS	1
34	011257-016	SCREW 5/8-11 UNC HHC X 2 LG	24
35	011238-010	WASHER SPLIT LOCK 5/8	24
36	011296-010	SCREW 1/2-13 SOCHDCAP X 1-1/4	8
37	011238-008	WASHER SPLIT LOCK 1/2	8
38	011239-008	WASHER FLAT ASTM A325 1/2	8
41	061796-099	GROMMET	FT 2.5
42	100385-099	HOSE GUARD (2.88 ID)	FT 5
43	065369-099	HOSE GUARD (1.42 ID)	6
44	100388-000	GASKET, WHEEL MOTOR PER PRINT	4



# Illustrated Parts Breakdown



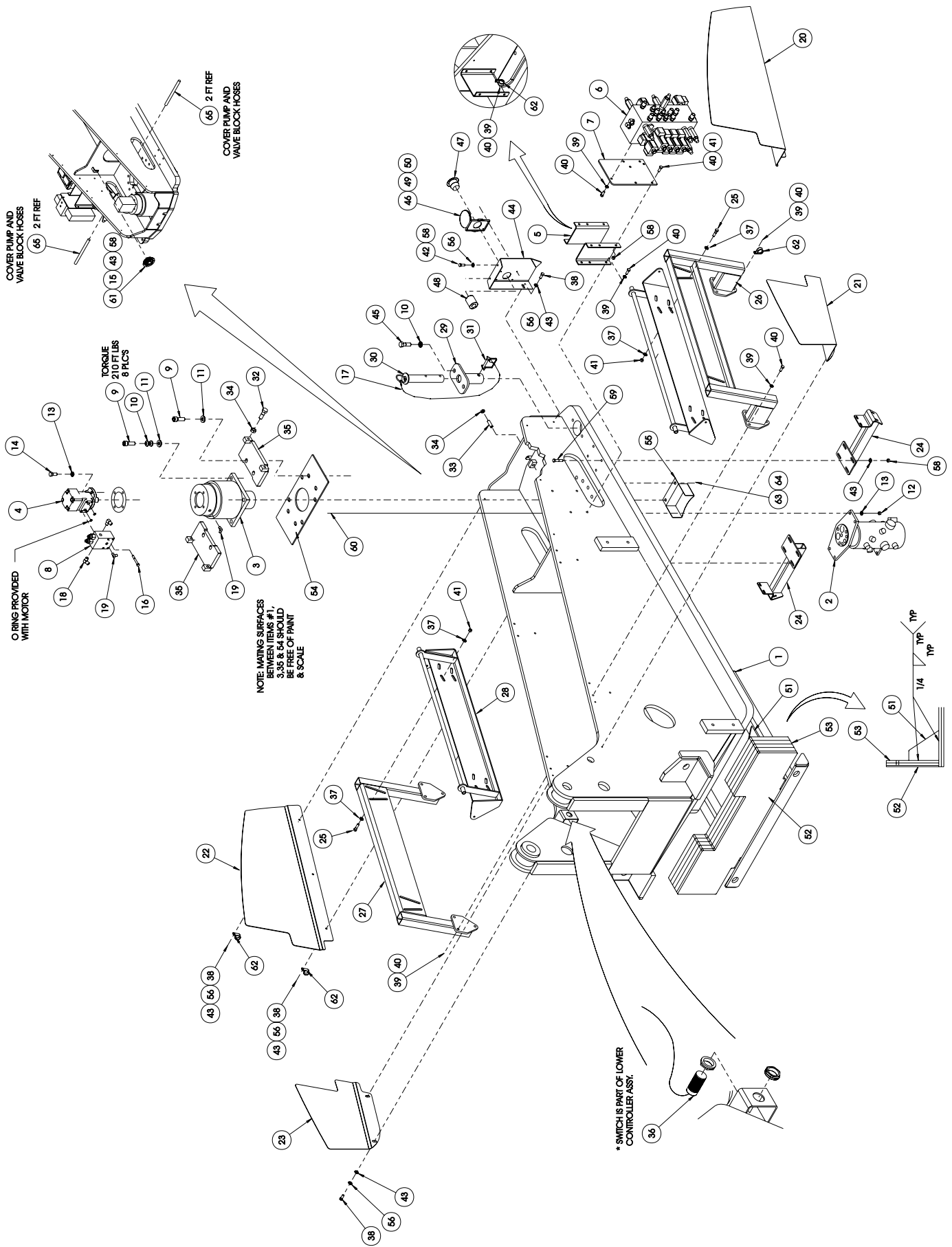
## TURRET ASSEMBLY

100010-000

ITEM	PART	DESCRIPTION	QTY.
1	100150-000	TURRET, MACHINED	1
2	100190-000	ROTARY MANIFOLD ASSEMBLY	1
3	100242-000	SWING GEAR BOX	1
*	100242-011	GASKET	1
4	100241-000	MOTOR	1
*	100241-010	SEALKIT	1
5	100267-000	VALVE MOUNT BRACKET	2
6	100264-000	CONTROL VALVE BLOCK ASSEMBLY	1
7	100266-000	MOUNT, VALVE BLOCK	1
8	100261-000	MOTOR VALVE BLOCK	1
9	011424-020	SCREW SOC HD CAP 5/8-11 UNC GR8 X 2-1/2	8
10	011238-101	WASHER SPLIT LOCK 5/8	2
11	100391-010	WASHER EXTRA THICK 5/8	8
12	011248-008	LOCKNUT, 1/2-13 UNC ESNA	4
13	011238-008	WASHER SPLIT LOCK 1/2	8
14	011256-008	SCREW HHC 1/2-13 UNC X 1	4
15	011253-006	SCREW HHC 5/16-18 UNC X 3/4 LG	1
16	011253-014	SCREW HHC 5/16-18 UNC X 1-3/4	2
17	063783-003	LANYARD ASSY X 12"	1
18	011941-009	FITTING 8MB-6MJ	2
19	011940-004	FITTING 90° 4MB-4MJ	2
20	100374-000	GUARD PANEL	1
21	100376-000	GUARD PANEL	1
22	100371-000	GUARD PANEL	1
23	100373-000	GUARD PANEL	1
24	100133-000	LATCH BRACKET WELDMENT	2
25	011254-010	SCREW HHC 3/8-16 UNC X 1-1/4	24
26	100365-000	MOUNTING PLATE WELDMENT	1
27	100360-000	MOUNTING PLATE WELDMENT	1
28	100356-000	PIVOT WELDMENT	2
29	100277-000	SLEW LOCK WELDMENT	1
30	100278-000	PIN, SLEW LOCK	1
31	100595-007	LOCKING PIN	1
32	011256-020	SCREW HHC 1/2-13 UNC X 2-1/2	4
33	011707-024	SCREW, SET HEX SOC 1/2-13 UNC X 3	2

ITEM	PART	DESCRIPTION	QTY.
34	011273-008	NUT, HEX JAM 1/2-13 UNC	6
35	100390-000	WELDMENT, GUIDE	2
36	REF	PROXIMITY SWITCH	REF
37	014996-006	WASHER, 0-3/8 FLAT STEEL	20
38	011253-006	SCREW, HHC 5/16-18 UNC X 3/4	5
39	011238-006	LOCKWASHER, 0-3/8 SPLIT RING	16
40	011254-008	SCREW, HHC 3/8-16 UNC X 1	16
41	011248-006	LOCKNUT, 3/8-16 UNC ESNA	16
42	011253-008	SCREW, HHC 5/16-18 UNC X 1	2
43	011240-005	WASHER 5/15 FLAT	21
44	100378-000	COVER	1
45	011253-012	SCREW HHC 5/8-11 UNC X 1-1/2	2
46	008942-001	COVER, RECEPTACLE	1
47	029961-000	INLET, MALE	1
48	029961-001	SEAL	1
49	011709-006	SCREW, RD. HD. #6-32 X 3/4	4
50	011248-047	LOCKNUT, HEX #6-32 ESNA	4
51	019928-213	GUSSET	2
52	019930-252	BALLAST PLATE 1/2"	REF
53	019936-035	BALLAST PLATE 1"	4
54	100066-001	SHIM, SLEW DRIVE	1
55	100379-000	GUARD, SLEW PINION-EURO ONLY	REF
56	011238-005	WASHER, SPLIT LOCK 5/16	7
57	011297-010	WASHER, BELLVILLE 5/8	8
58	011248-005	LOCKNUT, 5/16-18 UNC ESNA	6
59	011253-020	SCREW HHC 5/16-18 UNC X 2-1/2	8
60	011256-028	SCREW HHC 1/2-13 UNC X 3-1/2	4
61	029958-001	HORN 12 VOLT	1
62	013919-012	CLAMP	4
63	100384-008	SET SCREW 5/8-11 X 1 LG CUP POINT	REF
64	011273-010	JAM NUT 5/8-11	REF
65	100386-099	HOSE GUARD	FT 4

# Illustrated Parts Breakdown



# Illustrated Parts Breakdown

## MAIN BOOM ASSEMBLY, SB60

100009-000

ITEM	PART	DESCRIPTION	QTY.
1	100462-000	TIP BOOM WELDMENT	1
2	100464-000	BASE BOOM WELDMENT	1
3	100554-000	EXTENSION CYLINDER	1
*	100554-010	SEALKIT	1
*	100554-011	COUNTERBALANCE VALVE - 3,000 PSI	1
*	100554-012	COUNTERBALANCE VALVE - 1,500 PSI	1
4	100552-000	SLAVE CYLINDER	1
*	100552-010	SEALKIT	1
*	100552-011	COUNTERBALANCE VALVE	2
5	100612-000	SLIDE TUBE	1
6	100466-000	HOUSING WELDMENT, INNER	1
7	100607-000	HOUSING, OUTER - CARRIER TRACK	1
8	100685-000	CARRIER TRACK	1
9	011741-008	SCR, FLT. HD. SOC. 3/8-16 X 1	1
10	011254-052	SCR, HHC 3/8-16 UNC X 6-1/2 LG.	1
11	100487-000	SLIDE WELDMENT, EXT. CYL.	1
12	100469-000	BRACKET, SLIDE TUBE	1
14	100615-000	CLAMP, BASE END	4
15	100683-000	SLIDE PAD, TRACK SUPPORT	1
16	100609-000	SLIDE PAD, HOUSING END	2
17	100608-000	SLIDE PAD, TUBE END	1
18	100610-000	SLIDE PAD, OUTER	2
19	100611-000	SLIDE PAD, INNER	2
20	100621-000	SLIDE PAD, EXT. CYL. UPPER	2
21	100631-000	SLIDE PAD, EXT. CYL. UPPER	4
22	100617-000	SLIDE PAD	2
23	100489-000	WELDMENT, SLIDE PAD SUPPORT	2
24	100627-000	SHIM, SLIDE PAD (14 GA.)	4
25	100628-000	SHIM, SLIDE PAD (18 GA.)	4
26	100618-000	SLIDE PAD	2
27	100623-000	SLIDE PAD SUPPORT, UPPER BASE BOOM	2
28	100627-001	SHIM, SLIDE PAD (14 GA.)	AS REQD
29	100628-001	SHIM, SLIDE PAD (18 GA.)	AS REQD
30	100619-000	SLIDE PAD	2
31	100624-000	SLIDE PAD SUPPORT	2
32	026551-005	POP RIVET 0-1/8 (3/16-1/4 GRIP)	12
33	011254-012	SCR, HEX HD CAP 3/8-16 X 1-1/2	4
34	014996-006	WASHER, 3/8" FLAT	17
35	011248-006	LOCKNUT, HEX 3/8-16 UNC ESNA	14
36	011828-004	SCR. FLAT HD. SOC. 1/4-20 UNC X 1/2	16
37	011828-003	SCR. FLAT HS. SOC. 1/4-20 UNC X 3/8	32

ITEM	PART	DESCRIPTION	QTY.
38	100472-005	PIN WELDMENT	1
39	100472-004	PIN WELDMENT	1
40	100477-000	PIN, EXT. CYL. BASE	1
41	011254-006	SCR. HHC 3/8-16 UNC X 3/4" LG.	42
42	011238-006	LOCKWASHER, SPLIT LOCK 3/8"	32
43	100681-001	BACKING PLATE	4
44	100681-000	BACKING PLATE	4
45	011705-014	SET SCR. 3/8-16 UNC X 7/8	8
46	011273-006	NUT, HEX JAM 3/8-16 UNC.	8
47	014252-006	NUT-SERT 3/8-16 UNC	6
48	011252-014	SCR. HHC 1/4-20 UNC X 1-3/4	2
49	011248-004	LOCKNUT, HEX 1/4-20 UNC ESNA	8
50	011254-008	SCR. HHC 3/8-16 UNC X 1	8
51	014252-004	NUT-SERT 1/4-20 UNC	6
52	100269-001	VALVE BLOCK ASSY (MOTION CONTROL)	1
53	014412-008	SCREW SOC HD 10-24 UNC X 1	2
54	066097-014	SCR. FLT. HD. SOC. #10-24 X 1-3/4	4
55	011248-003	LOCKNUT, HEX #10-24 ESNA	10
56	100562-201	BEARING, GARMAX 2" X 3"	2
57	014996-004	WASHER, 1/4" FLAT	8
58	011821-008	SCR, BTN. HD. SOC. 1/4-20 UNC X 1	4
59	011252-017	SCR, HHC 1/4-20 UNC X 2-1/4	4
60	066097-006	SCR, FLT. HD. SOC. #10-24 X 3/4	4
61	011254-028	SCR, HHC 3/8-16 UNC X 3-1/2	1
2	100622-000	SLIDE PASSUPPORT	2
63	011934-004	FITTING, 90° 6MB-6MJ	1
64	011941-005	FITTING, STRAIGHT 6MB-6MJ	1
65	011937-003	FITTING, 90° 6FJX-6MJ	1
66	100696-000	BRACKET, MOUNT	1
67	065373-006	MAGNET, PROX. SWITCH	1
68	065373-005	SWITCH	1
69	100695-000	MOUNT, SWITCH	1
70	011240-003	WASHER, #10 FLAT	2
71	011709-004	SCREW, RD HD #10-24 UNC X 1/2	2
72	100620-000	SLIDE PAD	2

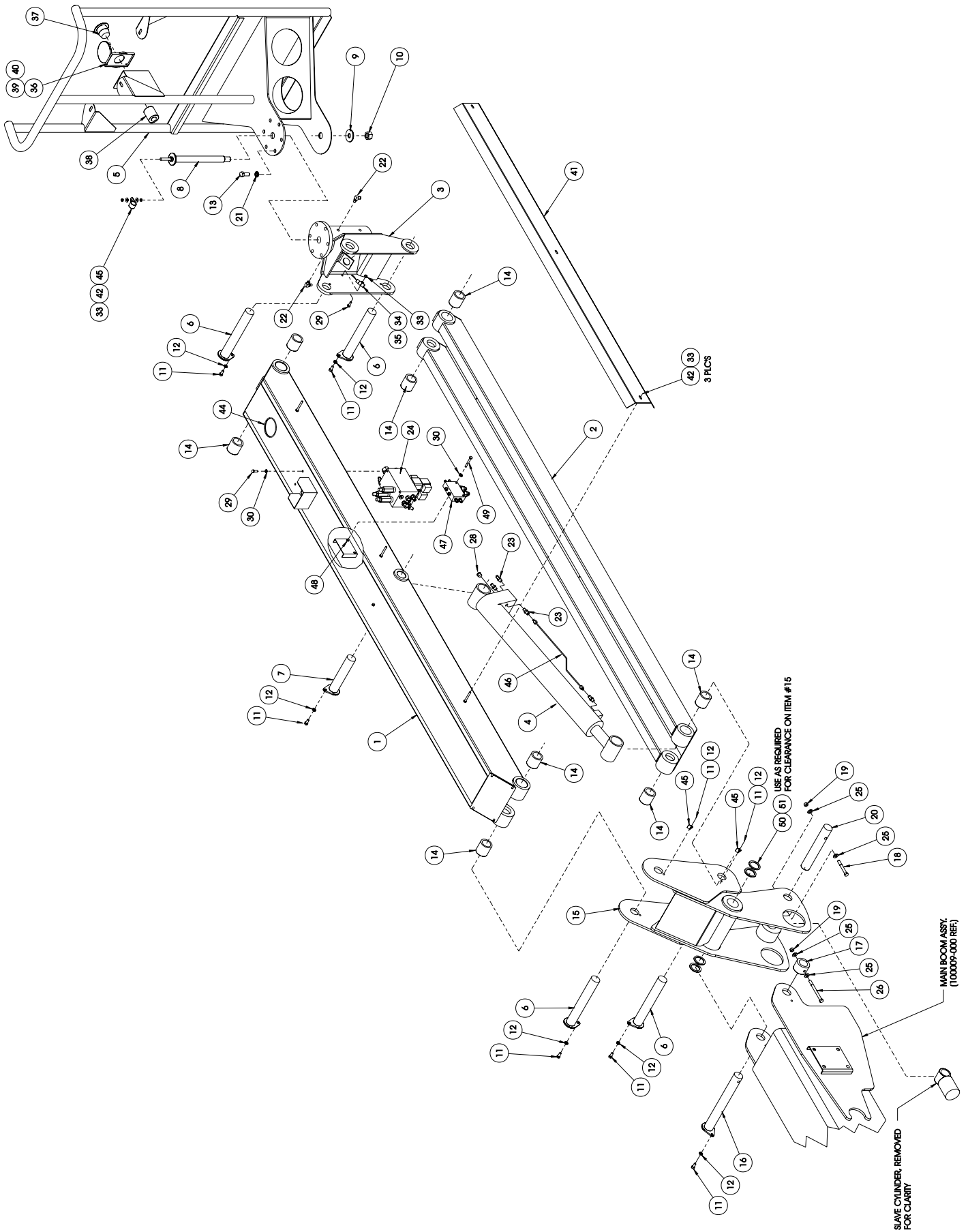


## JIB BOOM ASSEMBLY

100011-000

ITEM	PART	DESCRIPTION	QTY.
1	100456-000	UPPER JIB BOOM WELDMENT	1
2	100458-000	WELDMENT, JIB BOOM, LOWER	1
3	100550-000	HYDRAULIC ROTARY ACTUATOR	1
*	100550-010	SEALKIT	1
*	100550-011	BEARING KIT	1
4	100551-000	CYLINDER 3 BORE X 23.1 STROKE	1
*	100551-010	SEALKIT	1
5	100454-001	ROTATOR FRAME WELDMENT	1
6	100472-007	PIN WELDMENT	4
7	100472-008	PIN WELDMENT	1
8	100484-000	PIN WELDMENT, ROTATOR	1
9	011240-012	WASHER, 0-3/4" FLAT	1
10	011248-012	LOCKNUT, 3/4-10 UNC ESNA	1
11	011254-004	SCR, HHC 3/8-16 UNC X 1/2	8
12	011238-006	LOCKWASHER, 0-3/8 SPLIT RING	8
13	011256-010	SCR, HHC 1/2-13 UNC X 1-1/4	6
14	100562-150	BEARING	8
15	100459-000	JIB MOUNTING	1
16	100472-006	PIN WELDMENT	1
17	100688-000	RETAINER, JIB MOUNT PIN	1
18	011254-036	SCR, HHC 3/8-16 UNC X 4-1/2	1
19	011248-006	LOCKNUT, 3/8-16 UNC SENA	2
20	100480-000	PIN, ROD	1
21	011238-008	LOCKWASHER, 0-1/2 SPLIT RING	6
22	011934-001	FITTING, 90° ADAPTER 4MBX-4MJ	2
23	011941-001	FITTING, STR. ADAPTOR 4MB-4MJ	4
24	100283-001	VALVE BLOCK SH9S002011-A	1
25	014996-006	WASHER, 3/8" FLAT	4
26	011254-028	SCREW, HHC 3/8-16 UNC X 3-1/2	1
28	012004-006	PLUG, HOLLOW HEX #6 SAE	1
29	011252-006	SCREW, HHC 1/4-20 UNC X 3/4	4
30	011238-004	LOCKWASHER, 1/4" DIA.	5
33	011248-004	LOCKNUT, 1/4-20 UNC ESNA	6
34	063497-001	MERCURY SWITCH	1
35	013919-013	CLAMP	1
36	008942-001	COVER, RECEPTACLE	1
37	029961-002	PLUG, INLET FEMALE	1
38	029961-001	SEAL	1
39	011715-006	SCREW, RD. HD. #6-32 X 3/4	4
40	011248-047	LOCKNUT, HEX #6-32 ESNA	4
41	100692-000	COVER, JIB BOOM	1
42	011240-004	WASHER 1/4 FLAT	5
44	061692-099	3/16 GROMMET	FT 1.5
45	013919-012	CLAMP HOSE KMC COV 2113	3
46	100551-005	TUBE	1
47	100269-002	VALVE ASSEMBLY	1
48	014252-004	NUTSERT 1/4-20 UNC	2
49	011252-014	SCREW HHC 1/4-20 X 1-3/4 LG	2
50	100490-001	SHIM .062 MC #3088A-476	2
51	100490-002	SHIM .125 MC #3088A-521	2

# Illustrated Parts Breakdown



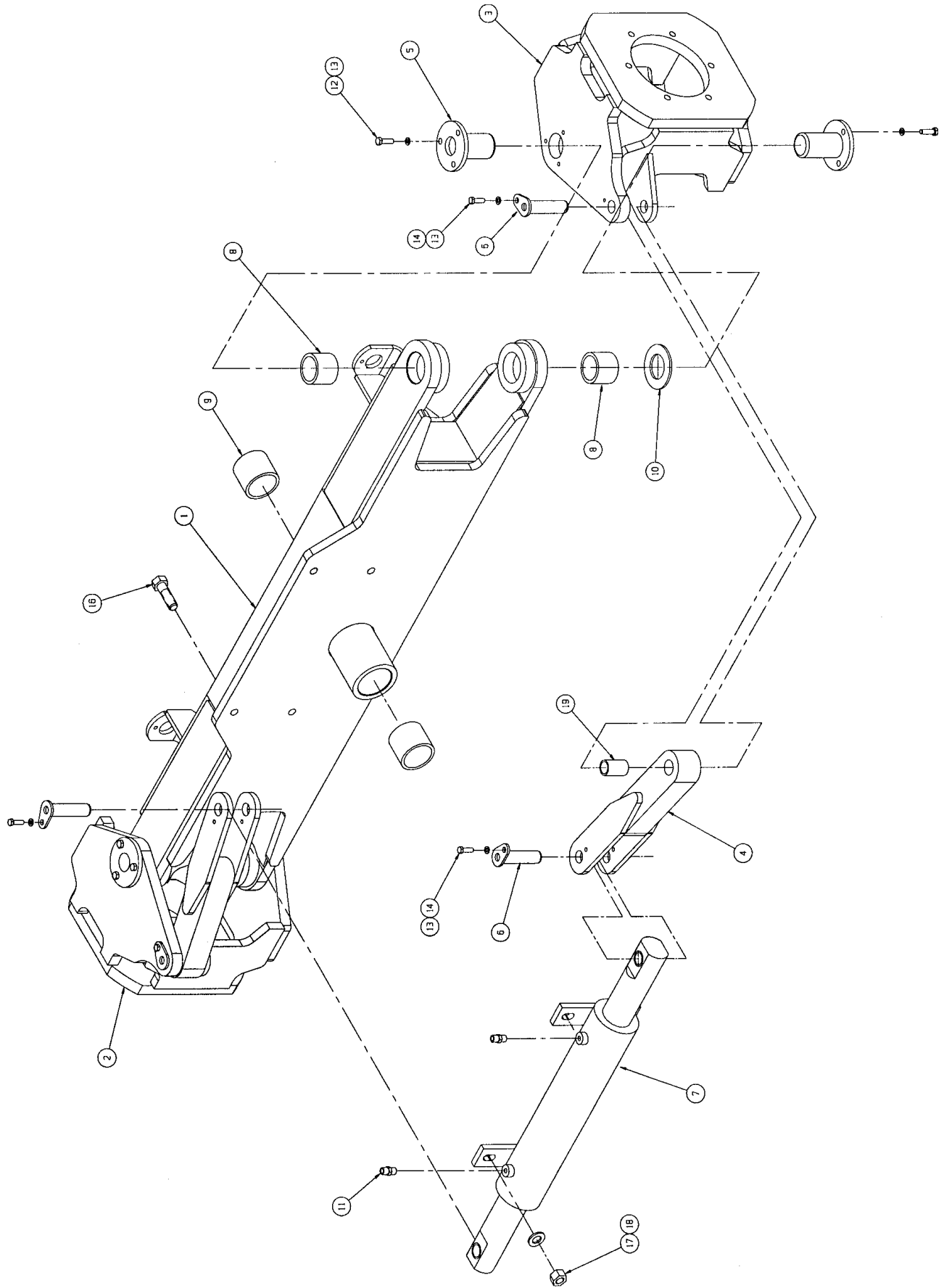
**FRONT AXLE ASSEMBLY**

100060-000

ITEM	PART	DESCRIPTION	QTY.
1	100061-000	STEERAXLEWELDMENT	1
2	100064-001	KNUCKLE-RHSTEER	1
3	100069-001	KNUCKLE-LHSTEER	1
4	100080-000	LINK-STEERING	2
5	100086-000	WELDMENT, KING PIN	4
6	100476-000	WELDMENT-PIN-STEERLINK	4
7	100557-000	STEERCYLINDER	1
*	100557-010	SEALKIT	1
8	100562-200	BEARING 2.0 ID GAR-MAX GM3240-32	4
9	100562-250	BEARING 2.5 ID GAR-MAX GM4048-40	2
10	100564-000	THRUST WASHER 2 IN ID	2
11	011941-005	FITTING 6MB-6MJ	2
12	011254-010	SCREW 3/8-16 UNC HHC X 1-1/4 LG	12
13	011238-006	WASHER SPLIT LOCK 3/8	16
14	011254-006	SCREW 3/8-16 UNC HHC X 3/4 LG	4
16	011257-020	SCREW 5/8-11 UNC HHC X 2.5 LG	4
17	011239-010	WASHER 5/8 FLAT ASTMA325	4
18	011248-010	LOCKNUT 5/8-11 UNC ESNA	4
19	100562-100	BEARING 1 TO GAR-MAX GM1620-032	2



# Illustrated Parts Breakdown



**ENGINE MODULE ASSEMBLY, SB60  
DIESEL**  
100012-000

ITEM	PART	DESCRIPTION	QTY.
1	100180-000	ENGINE, PERKINS DIESEL	1
2	100168-000	ENGINE MODULE WELDMENT	1
3	100248-000	PUMP, REXROTH	1
*	068668-005	SOLENOID	2
*	100248-010	SEALKIT	1
4	100715-000	PUMP, BARNES	1
5	100214-000	BRACKET, FILTER MOUNT	1
6	100185-000	BRACKET, MUFFLER/AIR CLEANER MOUNT	1
7	100562-150	BUSHING, GARLOCK 1-1/2 X 2	2
8	100210-000	BATTERY TRAY WELDMENT	1
9	062299-002	BATTERY, 12 VOLT	1
10	100323-000	VALVE BLOCK ASSY, BRAKE, AXLE LOCK, 2-SPEED	1
11	014693-002	FITTING REDUCER 8FJ-4MJ	1
12	100289-000	FILTER	1
*	100289-010	FILTER ONLY	1
13	100209-000	ENGINE MOUNT, ISOLATOR	4
14	068812-000	FLANGE KIT, 12SFXO	2
15	011934-019	FITTING, 90° ADAPTER 16MB-16MJ	1
16	011934-013	FITTING, 90° ADAPTER 12MB-8MJ	3
17	100433-001	FITTING, 45° ADAPTER 4MFFOR-4MB	1
18	100434-002	FITTING, 90° ADAPTER 4MFFOR-4MB	1
19	011941-010	FITTING, STR ADAPTER 8MB-8MJ	2
20	020733-003	FITTING, TEE ADAPTER 8FJX-8MJ-8MJ	3
21	011941-004	FITTING, STR ADAPTER 10MB-8MJ	1
22	011937-004	FITTING, 90° ADAPTER 8FJX-8MJ	1
23	011935-006	FITTING, 45° ADAPTER 10MB-10MJ	1
25	010150-005	FITTING BULKHEAD 8MJ-8MJ	1
26	013487-001	FITTING, STR ADAPTER 2MP-2MP	1
27	011915-001	FITTING, TEE ADAPTER 2FP-2FP-2FP	1
28	068954-001	OIL PRESSURE SWITCH	1
29	100333-000	OIL PRESSURE SENDING UNIT	1
30	011238-006	LOCKWASHER, 3/8" SPLIT RING	2
31	011254-008	SCREW, HHC 3/8-16 X 1	2
32	014996-008	WASHER, 1/2" FLAT	2
33	011238-008	LOCKWASHER, 1/2" SPLIT RING	4
34	011256-012	SCREW, HHC 1/2-13 X 1-1/2	2
35	011252-008	SCREW, HHC 1/4-20 X 1	2
36	014996-004	WASHER, 1/4" FLAT	18
37	011248-004	LOCKNUT, 1/4-20 UNC ESNA	18
38	011253-008	SCREW, HHC 5/16-18 X 1	2
39	011248-005	LOCKNUT, 5/16-18 UNC ESNA	10
40	011253-006	SCREW, HHC 5/16-18 X 3/4	4
41	011252-006	SCREW, HHC 1/4-20 X 3/4	20
42	011238-004	LOCKWASHER, 1/4" SPLIT RING	2
43	011254-024	SCREW, HHC 3/8-16 UNC X 3-1/2	4

ITEM	PART	DESCRIPTION	QTY.
44	011248-006	LOCKNUT 3/8-16 UNC ESNA	8
45	012039-000	J-BOLT, BATTERY HOLD-DOWN	2
46	064040-000	BATTERY HOLD-DOWN BAR	1
47	011252-022	SCREW, HHC 1/4-20 X 2-3/4	2
48	011254-006	SCREW, HHC 3/8-16 X 3/4	8
49	011253-007	SCREW, HHC 5/16-18 UNC X 7/8	4
50	011456-020	SCREW, HHC M12 X 1.75 X 20MM	2
51	100180-030	AIR CLEANER	
52	*	CLAMP, AIR CLEANER	
53	*	RAIN CAP	
54	100180-032	MUFFLER	
55	*	CLAMP, MUFFLER	
56	*	OVER-FLOW BOTTLE	
57	*	BRACKET, OVER-FLOW	
58	*	THROTTLE CONTROL	
59	*	SPLINED COUPLER	
60	*	GASKET, EXHAUST FLANGE	
61	*	NUT, EXHAUST FLANGE	
62	100180-034	EXHAUST PIPE	
63	*	EXHAUST CLAMP	
64	*	HOSE, AIR INTAKE	
66	067672-020	SCREW, HHC M8 X 1/25 X 20MM	4
67	011238-005	LOCKWASHER, 5/16" SPLIT RING	4
69	020541-024	HOSE CLAMP GATES #48	2
71	011934-020	FITTING, 90° ADAPTER 16MB-20MJ	1
72	068565-001	ACCUMULATOR (125 PSI)	1
73	100192-000	WASHER, SNUBBER	4
74	100318-000	MOUNTING BRACKET, ENGINE THROTTLE CONTROL	2
75	100332-000	SENDING UNIT, TEMP.	1
76	100324-000	POWER CONVERTER	1
77	012865-099	WIRE LOOM 3/4" FT	30
78	027972-000	SOLENOID, START 12 VOLT	2
79	011922-006	FITTING, STR. ADAPTER 6MP-8FP	1
80	017305-099	TUBE, 1/4 OD X 20 GA STEEL FT	.17
81	017303-099	TUBE, 5/16 OD X 20 GA STEEL FT	.17
82	020541-003	HOSE CLAMP GATES #6	4
83	012739-099	HOSE, 1/4 FUEL LINE FT	18
84	012733-099	HOSE, 5/16 FUEL LINE FT	18
85	063947-005	NUT, 5MM	1
86	063947-007	NUT, 7MM	1

**NOTE: Items 51-64 supplied with  
item 1, engine PN 100180-000**

\* Not shown

# Illustrated Parts Breakdown

Section  
**6.2**

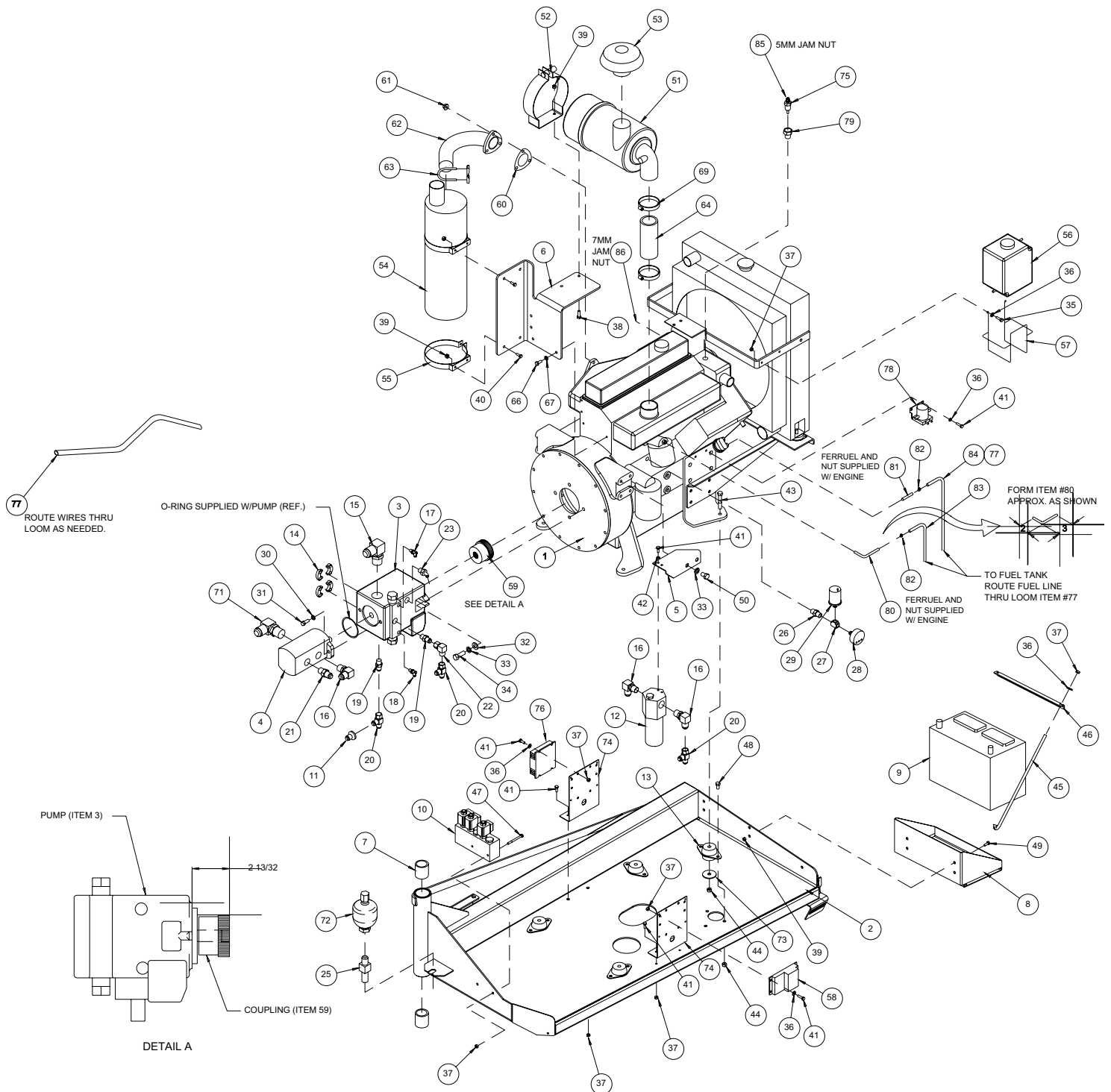
## ENGINE MODULE ASSEMBLY, SB60 DIESEL 100012-000

## ENGINE REPAIR PARTS SB60, DIESEL

ITEM	PART	DESCRIPTION	QTY.
201	100338-000	CONNECTOR, MALE (21 PIN)	1
202	100338-005	BOOT	1
205	100338-012	CONTACT, 12 GA SOCKET	3
207	100338-014	CONTACT, 16 GA SOCKET	15
209	068764-000	PLUG, SEALING	3
210	029480-099	WIRE, 10 GA RED	FT 6
211	029484-099	WIRE, 8 GA RED	FT 6
212	029452-099	WIRE, 16 GA BLACK	FT 6
213	029451-099	WIRE, 16 GA WHITE	FT 6
214	029454-099	WIRE, 16 GA RED	FT 6
215	029457-099	WIRE, 16 GA GREEN	FT 6
216	029453-099	WIRE, 16 GA ORANGE	FT 6
217	029450-099	WIRE, 16 GA BLUE	FT 6
218	029479-099	WIRE, 16 GA WHITE/BLACK	FT 6
219	029478-099	WIRE, 16 GA RED/BLACK	FT 6
220	005491-099	WIRE, 16 GA GREEN/BLACK	FT 6
221	029477-099	WIRE, 16 GA ORANGE/BLACK	FT 6
222	029475-099	WIRE, 16 GA BLUE/BLACK	FT 6
223	029351-099	WIRE, 16 GA BLACK/WHITE	FT 6
224	029352-099	WIRE, 16 GA RED/WHITE	FT 6
225	029353-099	WIRE, 16 GA GREEN/WHITE	FT 6
226	029354-099	WIRE, 16 GA BLUE/WHITE	FT 6
227	029470-099	WIRE, 12 GA RED	FT 6
228	064195-080	BATTERY CABLE ASSY X80LG	1
229	064195-050	BATTERY CABLE ASSY X50LG	1
230	029931-003	CONN FEM PUSH (.25) 16-14 GA	7
231	029617-002	CONN MALE PUSH (.25) 16-14 GA	6
232	029601-039	CONN RING TERM 0-5/16 12-10 GA	8
233	029601-012	CONN RING TERM. #8 0 16-14 GA	2
234	029620-003	CONNECTOR, BUTT 10-12 GA	3
235	029610-006	CONN FORK TERM #8 0 14-16 GA	4
236	029825-002	DIODE, 5 AMP	1
237	014435-001	BATTERY TERMINAL	2
238	029601-025	CONN RING TERM 0 5/16 8 GA	4
239	064195-032	BATTERY CABLE ASSY X32LG	1
240	029419-099	WIRE, 12 GA RED. GRN	6
241	029418-099	WIRE, 12 GA RED/BLK	12

ITEM	PART	DESCRIPTION	QTY.
*	100180-005	OIL FILTER	1
*	100180-006	FUEL FILTER	1
*	100180-007	FAN BELT	1
*	100180-008	INJECTOR	1
*	100180-009	STARTER	1
*	100180-010	STARTER SOLENOID	1
*	100180-011	ALTERNATOR	1
*	100180-012	ALTERNATOR BRACKET	1
*	100180-013	WATER PUMP	1
*	100180-014	WATER HOSE TOP	1
*	100180-015	WATER HOSE BOTTOM	1
*	100180-016	THERMOSTAT	1
*	100180-017	STARTER SOLENOID	1
*	100180-018	INJECTOR LINE	1
*	100180-019	INJECTOR LINE	1
*	100180-020	INJECTOR LINE	1
*	100180-021	INJECTOR LINE	1
*	100180-022	WATER HOSE BOTTOM	1
*	100180-023	THROTTLE LINK	1
*	100180-024	OIL DRAIN PLUG	1
*	100180-025	OIL DRAIN WASHER	1
*	100180-026	INT. MAIN GASKET	1
*	100180-027	EXHAUST MANIFOLD GASKET	1
*	100180-028	HEAD GASKET	1
*	100180-029	ALTERNATOR BRACKET 2	1
*	100180-030	AIR CLEANER	1
*	100180-031	THROTTLE CONTROL	1
*	100180-032	MUFFLER	1
*	100180-033	EXHAUST FLANGE	1
*	100180-034	EXHAUST PIPE	1
*	100180-035	EXHAUST FLANGE	1
*	100180-036	FLYWHEEL FLANGE	1
*	100180-037	THROTTLE ACTUATOR	1

# Illustrated Parts Breakdown



**ENGINE MODULE  
ASSEMBLY, DIESEL  
100012-000  
DRAWING 1 OF 2**



# Illustrated Parts Breakdown

## ENGINE MODULE ASSEMBLY, GAS 100013-000

ITEM	PART	DESCRIPTION	QTY.
1	100200-000	ENGINE, GM 3/1 LITER GASOLINE	1
2	100168-000	ENGINE MODULE WELDMENT	1
3	100248-000	PUMP, SYSTEM	1
*	068668-005	SOLENOID	2
*	100248-010	SEALKIT	1
4	100715-000	PUMP, SYSTEM	1
5	100214-000	BRACKET, FILTER MOUNT	1
6	100203-000	BRACKET, MUFFLER MOUNT	1
7	100205-000	BRACKET, AIR CLEANER MOUNT	1
8	100210-000	BATTERY TRAY WELDMENT	1
9	062299-002	BATTERY, 12 VOLT	1
10	100323-000	VALVE BLOCK ASSY, BRAKE, AXLE LOCK, 2-SPEED	1
11	014693-002	FITTING, 8JS-4MJ	1
12	100289-000	FILTER	1
*	1000289-010	FILTER ONLY	1
13	100209-000	ENGINE MOUNT, ISOLATOR	4
14	068812-000	FLANGE KIT, 12SFXO	2
15	011934-019	FITTING, 90° ADAPTER 16MB-16MJ	1
16	011934-013	FITTING, 90° ADAPTER 12MB-8MJ	3
17	100433-001	FITTING, 45° ADAPTER 4MFFOR-4MB	1
18	100434-002	FITTING, 90° ADAPTER 4MFFOR-4MB	1
19	011941-010	FITTING, STR ADAPTER 8MB-8MJ	2
20	020733-003	FITTING, TEE ADAPTER 8FJX-8MJ-8MJ	3
21	011941-004	FITTING, STR ADAPTER 10MB-8MJ	1
22	011937-004	FITTING, 90° ADAPTER 8FJX-8MJ	1
23	011941-015	FITTING, STR ADAPTER 10MB-10MJ	1
25	010150-005	FITTING BULKHEAD 8MJ-8MJ	1
26	013487-001	FITTING, STR ADAPTER 2MP-2MP	1
27	011915-001	FITTING, TEE ADAPTER 2FP-2FP-2FP	1
28	068954-001	OIL PRESSURE SWITCH	1
29	100333-000	OIL PRESSURE SENDING UNIT	1
30	011238-006	LOCKWASHER, 3/8" SPLIT RING	2
31	011254-008	SCREW, HHC 3/8-16 X 1	2
32	014996-008	WASHER, 1/2" FLAT	2
33	011238-008	LOCKWASHER, 1/2" SPLIT RING	2
34	011256-012	SCREW, HHC 1/2-13 X 1-1/2	2
35	011252-008	SCREW, HHC 1/4-20 X 1	2
36	014996-004	WASHER, 1/4" FLAT	10
37	011248-004	LOCKNUT, 1/4-20 UNC ESNA	14
38	011253-008	SCREW, HHC 5/16-18 X 1	2
39	011248-005	LOCKNUT, 5/16-18 UNC ESNA	10
40	011253-006	SCREW, HHC 5/16-18 X 3/4	4
41	011252-006	SCREW, HHC 1/4-20 X 3/4	10
42	011238-004	LOCKWASHER, 1/4" SPLIT RING	2

ITEM	PART	DESCRIPTION	QTY.
43	011254-024	SCREW, HHC 3/8-16 X 3-1/2	4
44	011248-006	LOCKNUT 3/8-16 UNC ESNA	12
45	012039-000	J-BOLT, BATTERY HOLD-DOWN	2
46	064040-000	BATTERY HOLD-DOWN BAR	1
47	011252-022	SCREW, HHC 1/4-20 X 2-3/4	2
48	011254-008	SCREW, HHC 3/8-16 X 1	8
49	100215-000	HOSE, AIR INTAKE	1
50	020541-024	HOSE CLAMP GATES #48	2
51	*	AIRCLEANER	
52	*	CLAMP, AIR CLEANER	
53	*	RAIN CAP	
54	*	MUFFLER	
55	*	CLAMP, MUFFLER	
56	*	OVER-FLOW BOTTLE	
57	*	BRACKET, OVER-FLOW	
58	100200-033	THROTTLE CONTROL	
59	*	SPLINED COUPLER	
60	*	FUEL PUMP, ELECTRIC	
61	*	EXHAUST PIPE	
62	*	FITTING, BARBED	
63	*	EXHAUST CLAMP	
65	011868-019	BUSHING, SNAP 7/8 DIA	1
66	011253-007	SCREW, HHC 5/16-18 UNC X 7/8	4
67	011934-020	FITTING, 90° ADAPTER 16MB-20MJ	1
69	020331-000	FUEL FILTER, INLINE	1
70	020541-003	HOSE CLAMP GATES #6	6
71	012739-099	HOSE, FUELLINE	FT 18
72	100562-150	BUSHING, GARLOCK 1-1/2 X 2	2
73	011923-004	FITTING 8MP-2FP	1
74	100318-000	MOUNTING BRACKET, ENGINE THROTTLE CONTROL	2
75	100332-000	SENDING UNIT, TEMP.	1
76	100324-000	POWER CONVERTER	1
77	012865-099	WIRE LDOM 3/4"	FT 30
78	011709-006	SCREW, HHC #10-24 X 3/4	4
79	011240-003	WASHER, #10-24 FLAT	4
80	011250-003	NUT, #10-24	4
81	100192-000	WASHER, SNUBBER	4
82	063947-005	NUT, 5MM	1
83	026526-004	SCREW SLFTP #10 AB SLOT HD X 1/2	2
84	068642-099	LOOM 1/2 BELDEN 737301	3
85	068565-001	ACCUMULATOR (125 PSI)	1

**NOTE:** Items 51-63 supplied with item 1, engine PN 100200-000

\* Not shown

# Illustrated Parts Breakdown

Section  
**6.2**

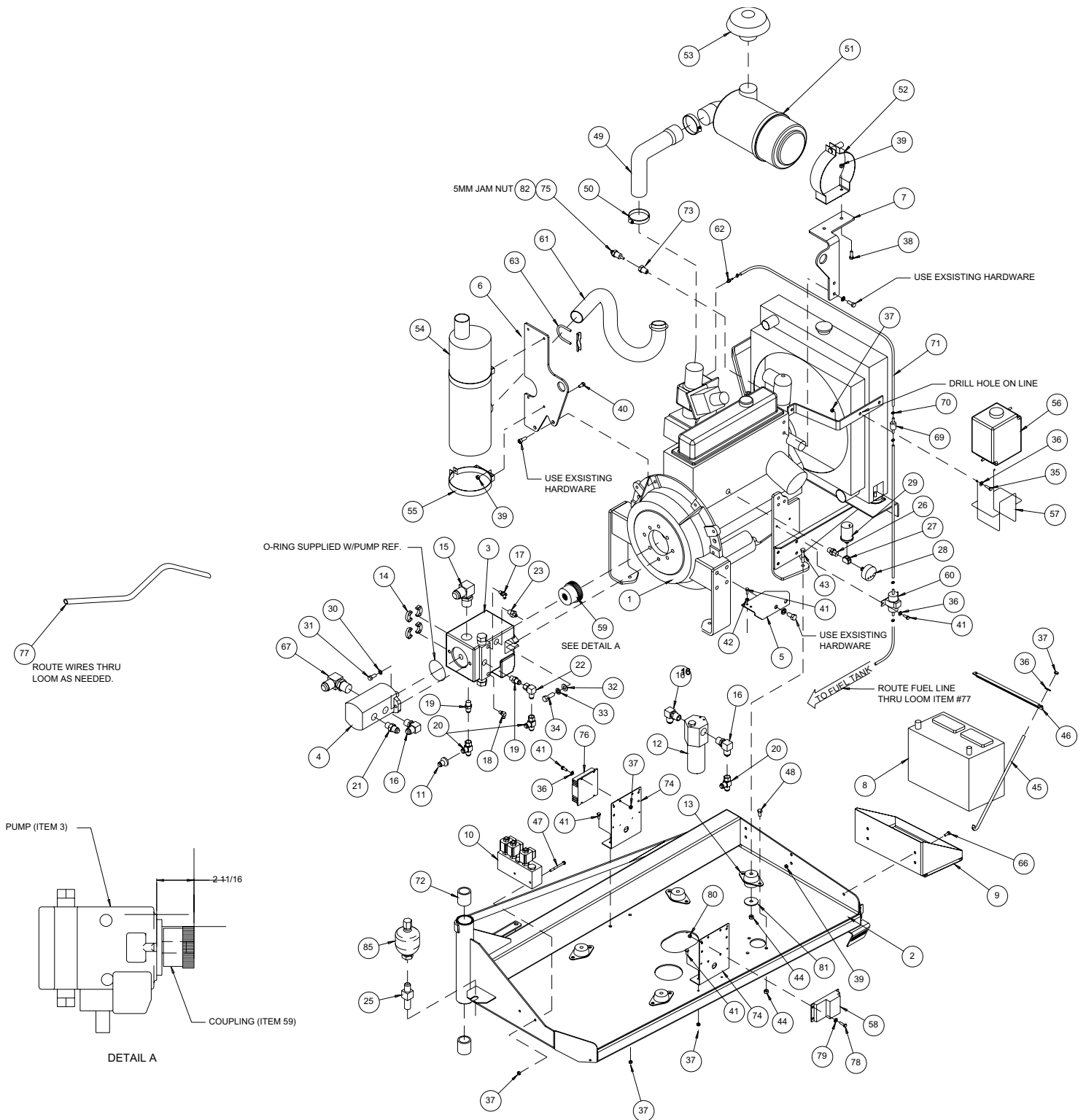
## ENGINE MODULE ASSEMBLY, GAS 100013-000

## ENGINE REPAIR PARTS SB60, GAS

ITEM	PART	DESCRIPTION	QTY.
201	100338-000	CONNECTOR, MALE (21 PIN)	1
202	100338-005	BOOT	1
205	100338-012	CONTACT, 12 GA SOCKET	3
207	100338-014	CONTACT, 16 GA SOCKET	15
208	029484-099	WIRE, 8 GA RED	FT 6
209	068764-000	PLUG, SEALING	3
210	067990-002	LOCKING WEDGE, MALE	1
211	067990-003	LOCKING WEDGE, FEMALE	1
212	029452-099	WIRE, 16 GA. BLACK	FT 6
213	029451-099	WIRE, 16 GA WHITE	FT 6
214	029454-099	WIRE, 16 GA RED	FT 6
215	029456-099	WIRE, 16 GA YELLOW	FT 6
216	029453-099	WIRE, 16 GA ORANGE	FT 6
217	029450-099	WIRE, 16 GA BLUE	FT 6
218	029479-099	WIRE, 16 GA WHITE/BLACK	FT 6
219	029472-099	WIRE, 12 GA BLACK	FT 12
220	005491-099	WIRE, 16 GA GREEN/BLACK	FT 6
221	029477-099	WIRE, 16 GA ORANGE/BLACK	FT 6
222	029475-099	WIRE, 16 GA BLUE/BLACK	FT 6
223	029351-099	WIRE, 16 GA BLACK/WHITE	FT 6
224	029352-099	WIRE, 16 GA RED/WHITE	FT 6
225	029353-099	WIRE, 16 GA GREEN/WHITE	FT 6
226	029354-099	WIRE, 16 GA BLUE/WHITE	FT 6
227	029470-099	WIRE, 12 GA RED	FT 18
228	064195-080	BATTERY CABLE ASSY X80 LG	2
229	064195-032	BATTERY CABLE ASSY X32 LG	1
230	029931-003	CONN. FEM PUSH (.25) 16-14 GA	7
231	029617-002	CONN. MALE PUSH (.25) 16-14 GA	6
232	029601-039	CONN. RING TERM. 0-5/16 12-10 GA	6
233	029601-012	CONN. RING TERM. #8 0-16-14 GA	1
234	029620-003	CONNECTOR, BUTT 10-12 GA	4
235	029610-006	CONN. FORK TERM, #8 0-14-16 GA	18
236	029825-002	DIODE	1
237	014435-001	BATTERY TERMINAL	2
238	029616-003	CONN. FEMALE PUSH 12-10	3
239	029419-099	WIRE, 12 GA RED/GRN	6
240	029418-099	WIRE, 12 GA RED/BLK	12
241	029601-025	CONN. RING TERM 0-5/16 8 GA	4

ITEM	PART	DESCRIPTION	QTY.
*	100200-005	OIL FILTER	1
*	100200-006	FUEL FILTER	1
*	100200-007	FAN BELT	1
*	100200-008	IGNITION	1
*	100200-009	DISTRIBUTOR	1
*	100200-010	STARTER BOLTS	1
*	100200-011	STARTER	1
*	100200-013	ALTERNATOR	1
*	100200-014	ALTERNATOR BRACKET	1
*	100200-015	WATER PUMP	1
*	100200-016	WATER PUMP GASKET	1
*	100200-017	WATER HOSE, TOP	1
*	100200-018	WATER HOSE, BOTTOM	1
*	100200-019	THERMOSTAT	1
*	100200-020	THERMOSTAT GASKET	1
*	100200-021	SPARK PLUGS	1
*	100200-022	SPARK PLUG WIRES	1
*	100200-023	CARBURETOR	1
*	100200-024	CARBURETOR GASKET	1
*	100200-025	DISTRIBUTOR CAP	1
*	100200-026	DISTRIBUTOR ROTOR	1
*	100200-027	GOVERNOR ASSEMBLY	1
*	100200-028	OIL DRAIN PLUG	1
*	100200-029	OIL DRAIN WASHER	1
*	100200-030	INT. EXHAUST MANIFOLD GASKET	1
*	100200-031	HEAD GASKET	1
*	100200-032	VALVE COVER GASKET	1
*	100200-033	THROTTLE CONTROL	1
*	100200-034	ACTUATOR LINKAGE	1
*	100200-035	GOVERNOR CONTROL	1
*	100200-036	COUPLER KIT-SPLINE	1

# Illustrated Parts Breakdown



**ENGINE MODULE  
ASSEMBLY, GAS  
100013-000  
DRAWING 1 OF 2**



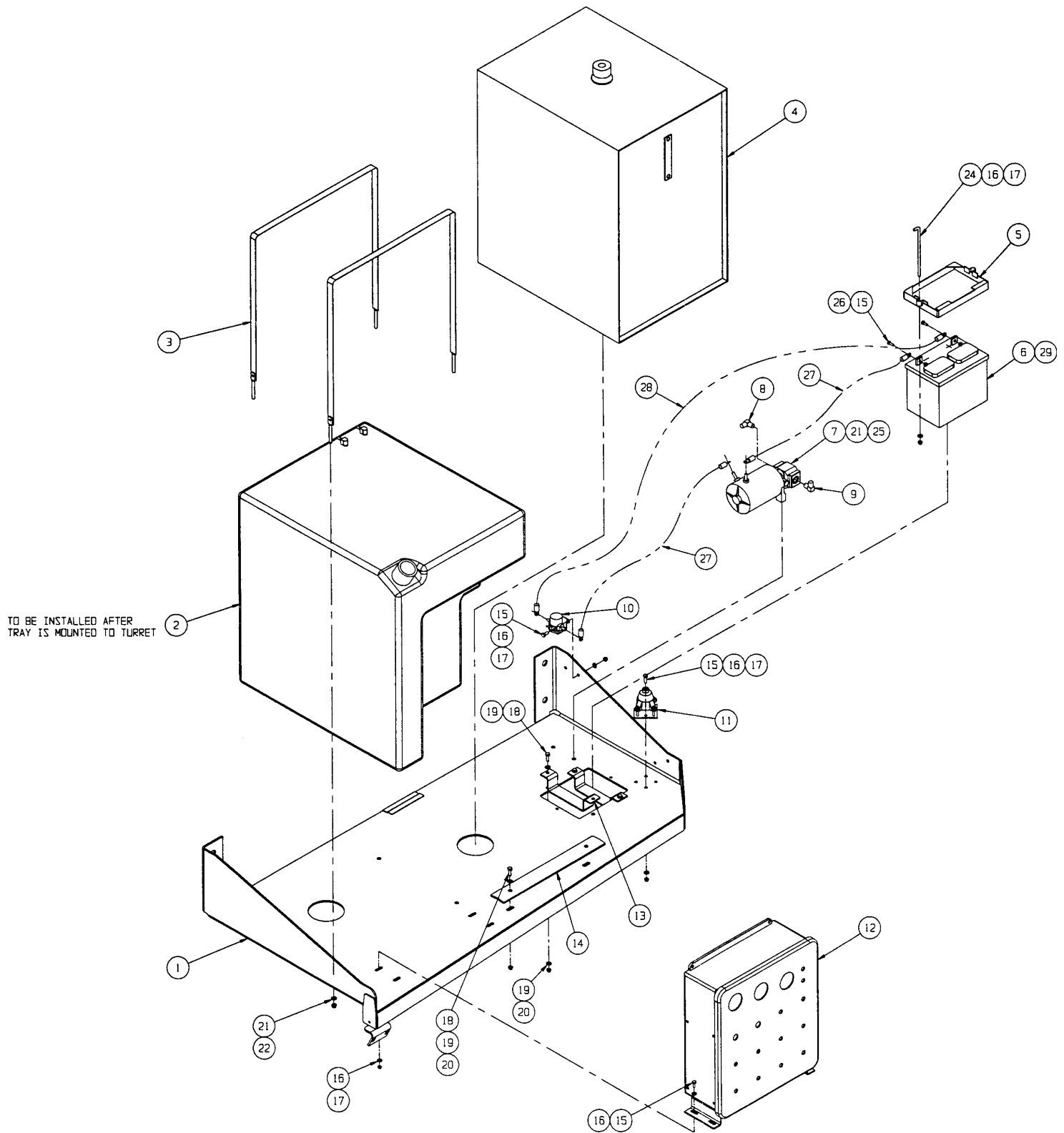


## CONTROL MODULE ASSEMBLY

100014-000GAS/100014-001DIESEL

ITEM	PART	DESCRIPTION	QTY.
1	100176-000	CONTROL MODULE TRAY WELDMENT	1
2	100270-001	FUEL TANK ASSY (GAS)	1
	100270-000	FUEL TANK ASSY (DSL)	1
3	100274-000	TANK STRAP	2
4	100271-000	HYDRAULIC RESERVOIR ASSY	1
5	100294-000	BATTERY HOLD DOWN	1
6	100293-000	BATTERY AUX 12V	1
7	100239-000	POWER UNIT (EMERGENCY LOWERING)	1
8	011937-006	FITTING SWIVEL 90° 10FJX-10MJ	1
9	011934-004	FITTING AERO 2062-6-6S	1
10	027972-000	SOLENOID	1
11	029945-018	LEVEL SENSOR (GAS & DSL DOM)	REF
	029945-013	LEVEL SENSOR (DSL EURO)	REF
12	100019-000	LOWER CONTROL BOX ASSY (GAS)	1
	100018-000	LOWER CONTROL BOX ASSY (DSL)	1
13	100216-000	BATTERY SUPPORT BRACKET	2
14	100313-000	TANK TAB	1
15	011252-008	SCREW HHC GRS 1/4-20 UNC X 1	10
16	014996-004	WASHER 1/4 SAE FLAT PLTO	16
17	011248-004	NUT HEX ESNA 1/4-20 UNC	12
18	011253-012	SCREW HHC GRS 5/16-18 UNC X 1-1/4	2
19	014996-005	WASHER 5/16 SAE FLAT PLTO	6
20	011248-005	NUT HEX ESNA 5/16-18 UNC	2
21	011240-006	WASHER, STD FLAT 3/8	4
22	011248-006	NUT HEX ESNA 3/8-16 UNC	2
24	100295-000	J-BOLT	2
25	011254-006	SCREW HHC GRS 3/8-16 UNC X 3/4	2
26	011250-004	NUT HEX 1/4-20 UNC	2
27	064195-010	BATTERY CABLE ASSY X 10	REF
28	064195-019	BATTERY CABLE ASSY X 19	REF
29	010154-000	COVER, BATTERY TERMINAL	2

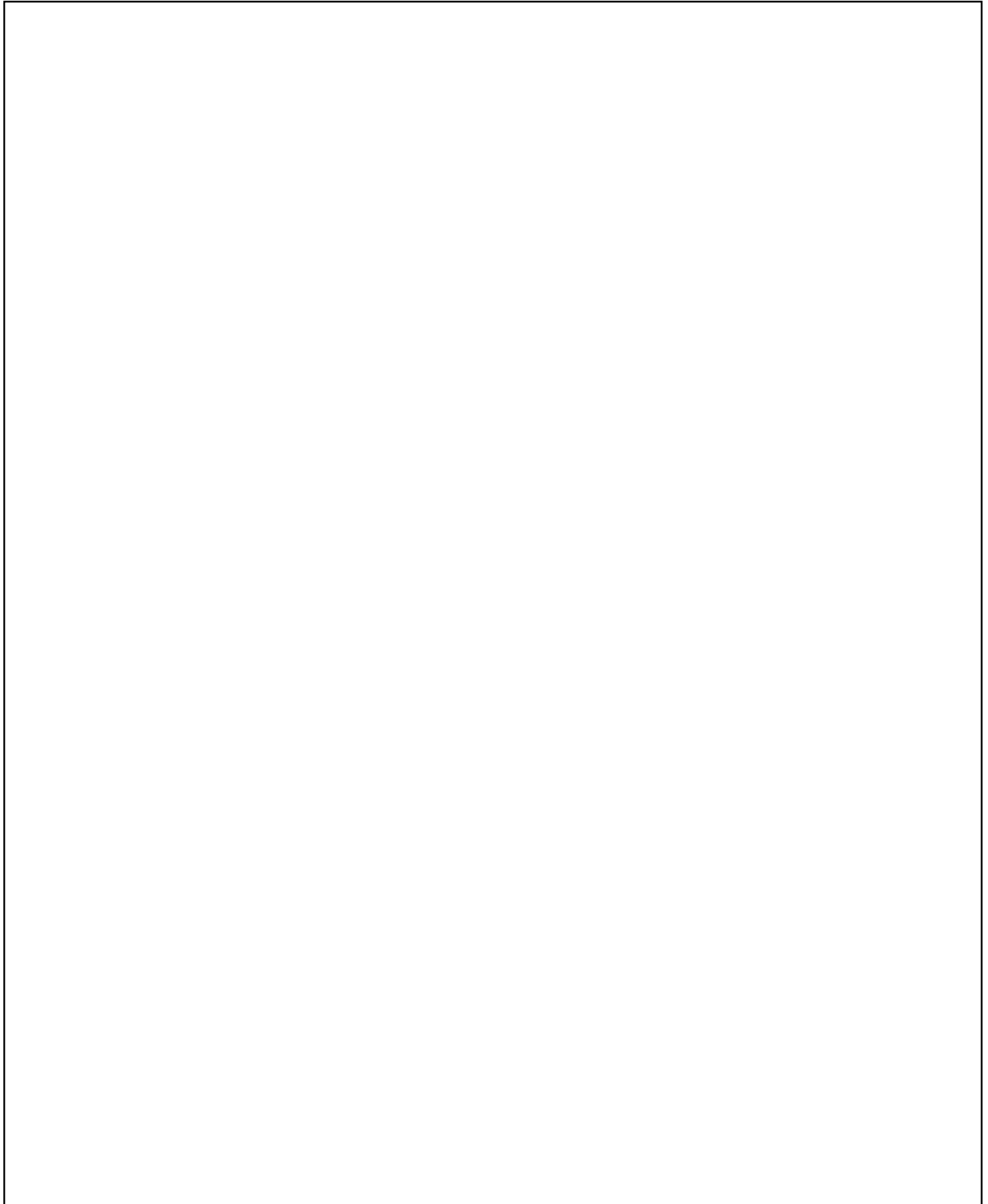
# Illustrated Parts Breakdown



**HOSE KIT, CHASSIS****SB60**

100421-000

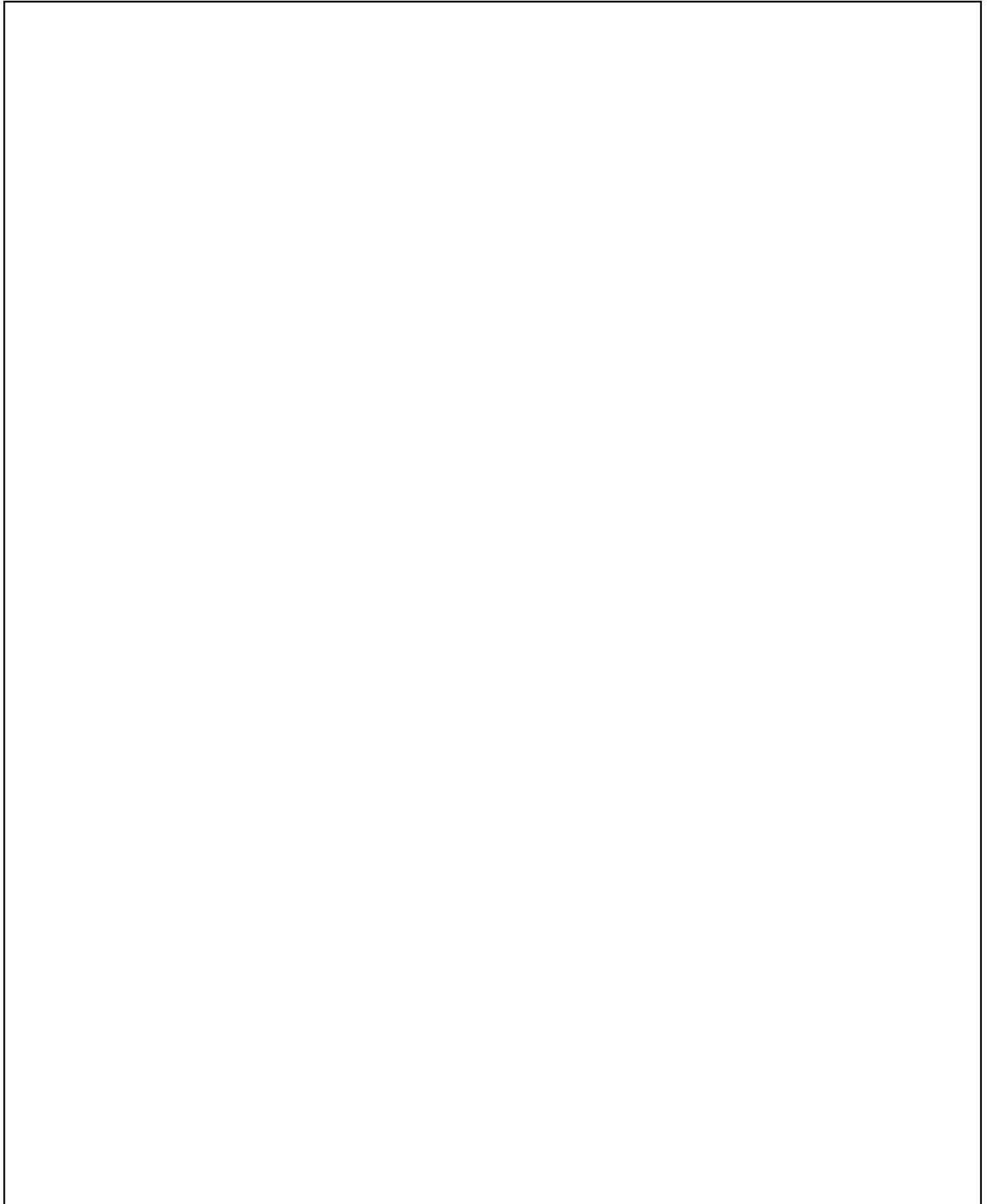
ITEM	PART	DESCRIPTION	QTY.
1	068737-040	1/4"HOSE ASSY X 40" 4FJX-4FJX	2
2	068737-035	1/4"HOSE ASSY X 35" 4FJX-4FJX	1
3	100424-060	1/4"HOSE ASSY X 60" 4FFORX-4FFORX	4
4	068737-066	1/4"HOSE ASSY X 66" 4FJX-4FJX	2
5	068737-034	1/4"HOSE ASSY X 34" 4FJX-4FJX	1
6	100424-040	1/4"HOSE ASSY X 40" 4FFORX-4FFORX	2
7	100424-066	1/4"HOSE ASSY X 66" 4FFORX-4FFORX	2
8	068737-060	1/4"HOSE ASSY X 60" 4FJX-4FJX	2
9	100424-035	1/4"HOSE ASSY X 35" 4FFORX-4FFORX	3
10	068745-080	3/8"HOSE ASSY X 80" 6FJX-6FJX	2
11	064156-035	1/2"HOSE ASSY X 35" 8FJX-8FJX	1
12	064156-017	1/2"HOSE ASSY X 33" 8FJX-8FJX	1
13	064156-042	1/2"HOSE ASSY X 57" 8FJX-8FJX	2
14	064156-003	1/2"HOSE ASSY X 64" 8FJX-8FJX	2
15	100425-060	1/2"HOSE ASSY X 60" 12FFORX-FLANGE	4
16	100426-066	1/2"HOSE ASSY X 66" 8FFORX-FLANGE 90	4
17	068745 017	3/8"HOSE ASSY X 17" 6FJX-6FJX	1
18	068745-046	3/8"HOSE ASSY X 46" 6FJX-6FJX	1
19	100427-080	3/4"HOSE ASSY X 80" 12FFOSX-12FFORX	1
20	100427-030	3/4"HOSE ASSY X 30" 12FFORX-12FFORX	1
21	100427-058	3/4"HOSE ASSY X 58" 12FFORX-12FFORX	1
22	100429-012	1/2"HOSE ASSY X 12" 8FFORX-8FFORX	2
23	020032-001	FITTING, TEE 4MJ-4MJ-4MJ	REF
24	100436-001	FITTING, TEE 4MFFOR-4MFFOR-4MFFOR	REF
25	100429-015	1/2"HOSE ASSY X 15" 8FFORX-8FFORX	1
26	020032-004	FITTING, TEE 8MJ-8MJ-8MJ	REF
27	100427-018	3/4"HOSE ASSY X 18" 12FFORX-12FFORX	1



**HOSE KIT, TURRET****SB60**

100421-000

ITEM	PART	DESCRIPTION	QTY.
200	100424-054	1/4 HOSE X 54 LG 4FFORX-4FFORX	1
201	068737-080	1/4 HOSE X 80 LG 4FJX-4FJX	1
204	068737-014	1/4 HOSE X 14 LG 4FJX-4FJX	1
205	100424-016	1/4 HOSE X 16 LG 4FFORX-4FFORX	2
208	060861-019	3/8 HOSE X 22 LG 6FJC-6FJX	1
209	060861-011	3/8 HOSE X 46 LG 6FJX-6FJX	2
210	1004240-051	1/4 HOSE X 51 LG 4FFORX-4FFORX	1
211	060861-078	3/8 HOSE X 57 1/2 LG 6FJX-6FJX	1
212	068743-090	5/8 HOSE X 90 LG 10FJX-10FJX	1
214	064156-001	1/2 HOSE X 11 LG 8FJX-8FJX	1
215	064156-040	1/2 HOSE X 40 LG 8FJX-8FJX	1
216	064156-024	1/2 HOSE X 52 LG 8FJX-8FJX	1
217	064156-010	1/2 HOSE X 62 LG 8FJX-8FJX	1
218	064156-049	1/2 HOSE X 20 LG 8FJX-8FJX	1
219	064156-047	1/2 HOSE X 22 LG 8FJX-8FJX	1
220	064156-045	1/2 HOSE X 19 LG 8FJX-8FJX	1
221	067682-027	1/2 HOSE X 27 LG 8FJX-8FJX 90°	1
222	100431-051	3/4 HOSE X 51 LG 12FFORX-FLANGE 90°	1
224	100438-094	1 HOSE X 94 LG 16FJX-16MP	1
225	100439-088	1-1/4" HOSE X 88 LG 20FJX-20MP	1
226	100431-058	3/4 HOSE X 58 LG 12FFORX-FLANGE 90°	1



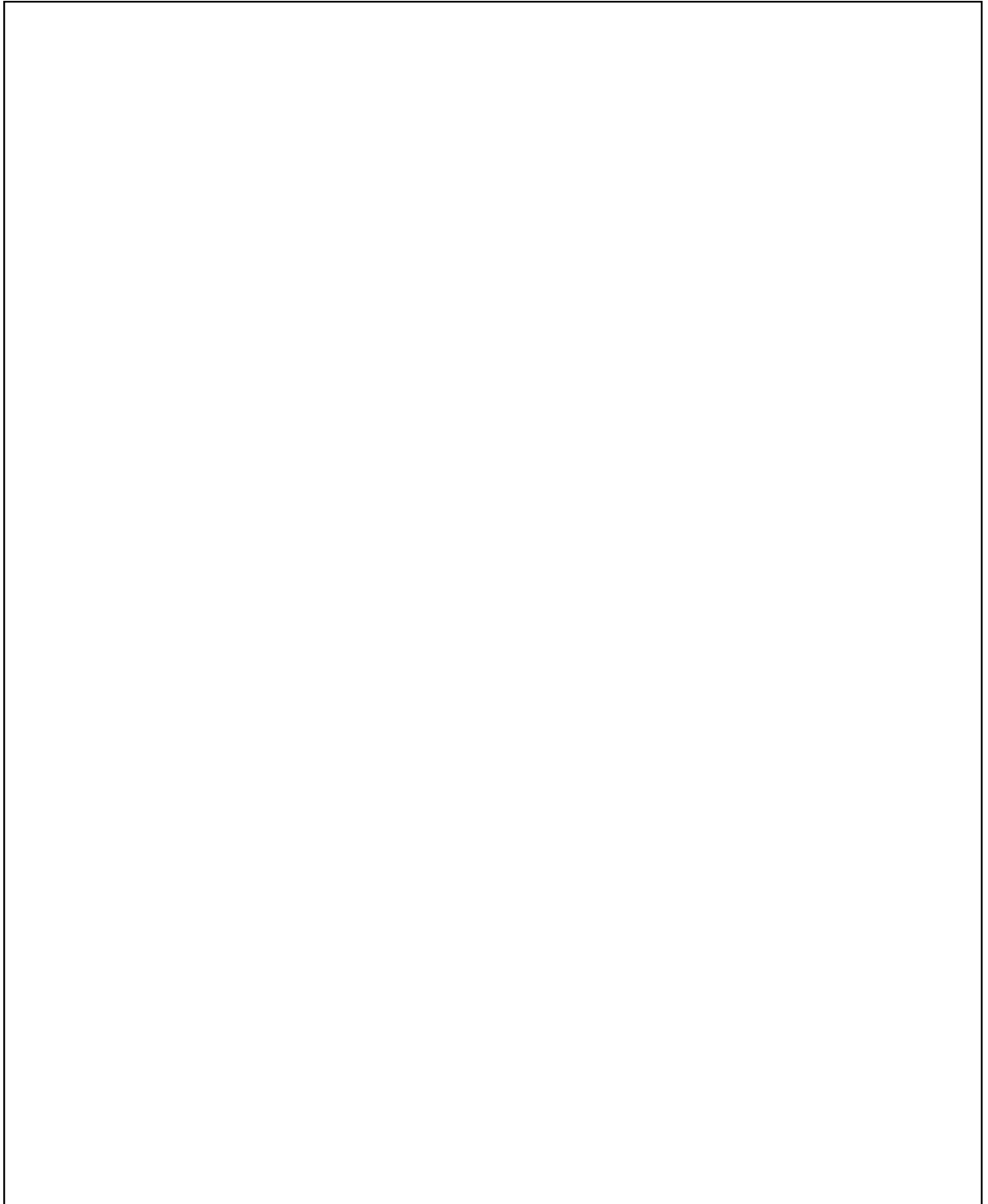
HOSE KIT, BOOM

SB60

100421-000

ITEM	PART	DESCRIPTION	QTY.
300	068737-020	1/4 HOSE X 20 LG 4FJX-4FJX	1
301	068737-030	1/4 HOSE X 30 LG 4FJX-4FJX	2
302	068737-040	1/4 HOSE X 40 LG 4FJX-4FJX	3
303	068737-009	1/4 HOSE X 9 LG 4FJX-4FJX	1
304	068737-580	1/4 HOSE X 580 LG 4FJX-4FJX	2
305	068737-880	1/4 HOSE X 880 LG 4FJX-4FJX	1
306	068737-890	1/4 HOSE X 890 LG 4FJX-4FJX	1
307	067681-048	1/4 HOSE X 48 LG 4FJX-4FJX 90°	1
308	068737-025	1/4 HOSE X 25 LG 4FJX-4FJX	2
309	067681-060	1/4 HOSE X 60 LG 4FJX-4FJX 90°	1
311	060861-115	3/8 HOSE X 51 LG 6FJX-6FJX	2
313	060861-120	3/8 HOSE X 120 LG 6FJX-6FJX	2
314	060861-150	3/8 HOSE X 150 LG 6FJX-6FJX	2
315	060861-210	3/8 HOSE X 210 LG 6FJX-6FJX	2





# Illustrated Parts Breakdown

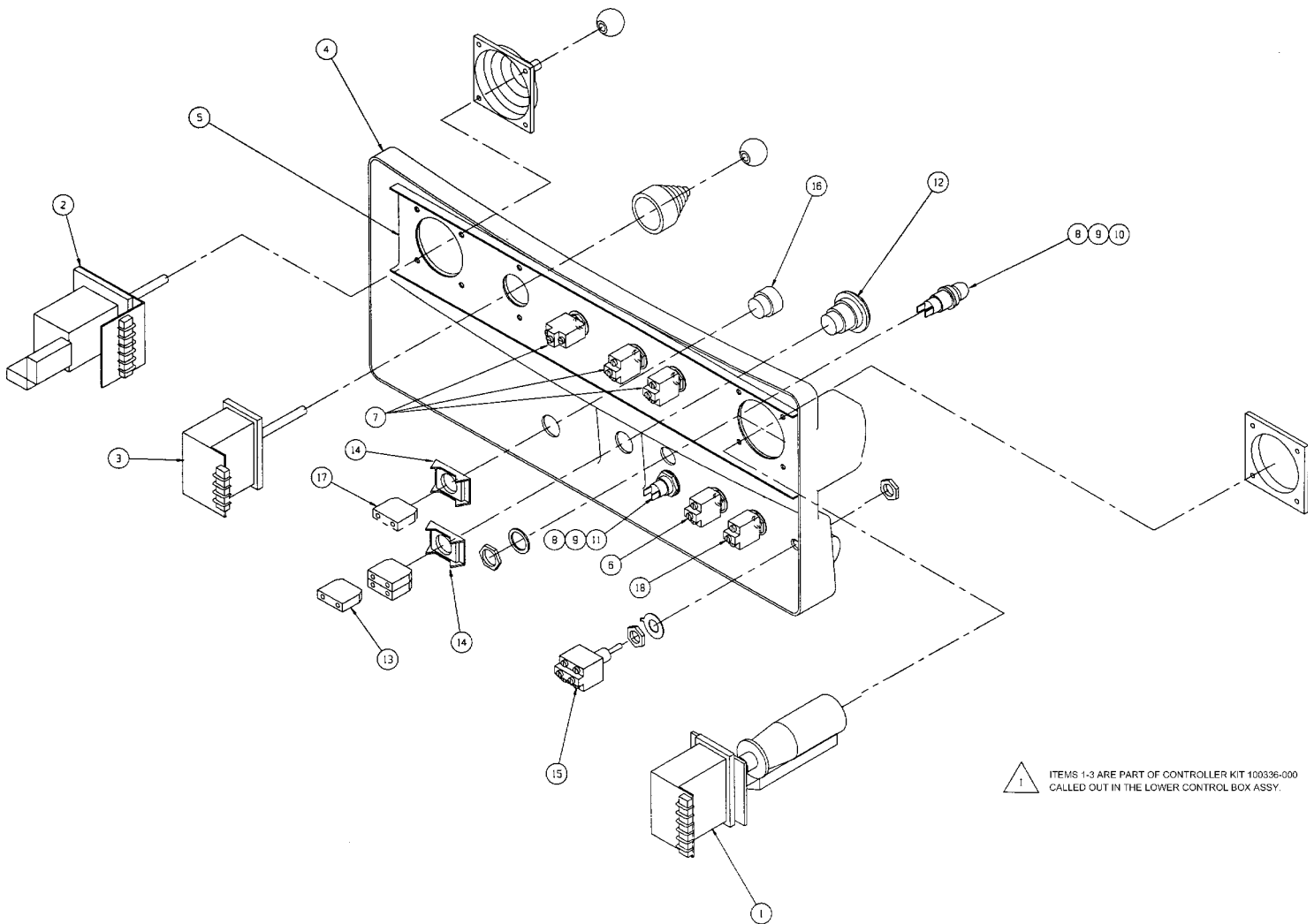
## UPPER CONTROLLER ASSEMBLY DIESEL 100016-001

ITEM	PART	DESCRIPTION	QTY.
1	100325-000	DRIVE CONTROLLER	1
*	066786-015	BOOT, ROCKER SWITCH	1
*	066786-024	STEERING MICRO SWITCH	1
*	063913-001	BOOT, HANDLE	1
*	068592-008	DRIVE MICRO SWITCH	1
*	066786-011	HANDLE HALF, FRONT	1
*	066786-012	HANDLE HALF, REAR	1
*	066786-013	GASKET, HANDLE	1
*	066786-021	SWITCH, PUSH BUTTON	1
2	100326-000	LIFT CONTROLLER	1
3	100327-000	EXTEND CONTROLLER	1
*	068592-008	DRIVE MICRO SWITCH	1
4	100309-000	UPPER CONTROL BOX	1
5	100310-000	STIFFENER, UPPER CONTROLLER	1
6	012797-000	SWITCH TOGGLE SPDT MAINTAINED	1
7	012798-006	SWITCH TOGGLE SPDT MOMENTARY	3
8	068590-000	BASE INDICATOR LAMP	2
9	068591-001	LAMP T-2 1/2	2
10	068595-002	LENS AMBER	1
11	068595-001	LENS RED	1
12	064446-003	EMERGENCY STOP BUTTON	1
13	064443-002	CONTACT BLOCK NC	3
14	064417-001	FLANGE MOUNT	2
15	012798-005	SWITCH TOGGLE DPDT MOMENTARY	1
16	067654-000	PUSH BUTTON, FLUSH (BLACK)	1
17	064443-001	CONTACT BLOCK NO	1
18	012798-006	TOGGLE SWITCH	1
201	100309-000	UPPER CONTROL BOX	REF
202	029925-002	CONNECTOR CABLE 1/2 NPT	2
203	029939-002	LOCKNUT 1/2 NPT	2
204	100334-000	SWITCH, LEVER	1
205	067893-000	MOUNTING RAIL DIN X 13 LG	1
206	067660-006	TERMINAL END	2
207	067661-001	RELAY SPDT 12VDC	4
208	067661-004	RELAY 4PDT 12VDC	1
209	068698-001	TERMINAL BLOCK (TAN)	23
210	068698-000	TERMINAL BLOCK (ORANGE)	2
211	068698-004	END CAP, CONTACT BLOCK	1
212	067662-001	RELAY SOCKET SPDT	5
213	067662-004	RELAY SOCKET 4PDT	1
214	067662-005	RETAINER CLIP ASSY	4
215	067662-007	RETAINER CLIP ASSY	1
216	015790-006	CONNECTOR RECEPTACLE	1
217	015790-004	PIN CONTACT 16-18G	27
218	015790-007	PIN CONTACT 14-16G	3
219	066807-001	ALARM 107DB	1

ITEM	PART	DESCRIPTION	QTY.
220	100319-000	HINGE SOUTHCO C6-30	2
221	013965-006	SCREW HHC #10-24 X 3/4 LG	8
222	011240-003	WASHER #10 FLAT	8
223	068698-002	TERMINAL BLOCK (BLUE)	2
224	011715-006	SCREW RD HD MACHINE #6-32 X 3/4 LG	6
225	011240-001	WASHER #6 FLAT	12
226	011248-047	LOCKNUT #6-32	6
227	100337-099	O-RING CORD 3/16 FT	3.5
229	68773-002	JUMPER, 2 PIN	4
230	100707-000	INNER STIFFENER	1
231	100708-000	OUTER STIFFENER	1
232	011252-006	SCREW 1/4-20 UNC HHC X 3/4 LG	1
233	011240-004	WASHER 1/4 FLAT	2
234	011248-004	LOCKNUT 1/4-20 UNC	1
235	011248-003	LOCKNUT 10-24 UNC	8
301	029452-099	WIRE, 16 GA BLACK FT	10
302	029451-099	WIRE, 16 GA WHITE FT	10
303	029454-099	WIRE, 16 GA RED FT	10
304	029457-099	WIRE, 16 GA GREEN FT	10
305	029450-099	WIRE, 16 GA BLUE FT	10
306	029479-099	WIRE, 16 GA WHITE/BLACK FT	10
307	029478-099	WIRE, 16 GA RED/BLACK FT	10
308	005491-099	WIRE, 16 GA GREEN/BLACK FT	10
309	029351-099	WIRE, 06 GA BLACK/WHITE FT	10
310	029352-099	WIRE, 16 GA RED/WHITE FT	10
311	029353-099	WIRE, 16 GA GREEN/WHITE FT	10
312	029354-099	WIRE, 16 GA BLUE/WHITE FT	10
313	029355-099	WIRE, 16 GA BLACK/RED FT	10
314	029358-099	WIRE, 16 GA BLUE/RED FT	10
315	029356-099	WIRE, 16 GA WHITE/RED FT	10
316	029360-099	WIRE, 16 GA ORANGE/GREEN FT	10
317	029456-099	WIRE, 16 GA YELLOW FT	10
318	029477-099	WIRE, 16 GA ORANGE/BLACK FT	10
319	029475-099	WIRE, 16 GA BLUE/BLACK FT	10
320	029359-099	WIRE, 16 GA RED/GREEN FT	10
321	029455-099	WIRE, 16 GA BROWN FT	10
322	029362-099	WIRE, 16 GA RED/BLACK/WHITE FT	10
323	029453-099	WIRE, 16 GA ORANGE FT	10
324	029488-099	WIRE, 16 GA, 6 COND FT	10
325	029461-099	WIRE, 14 GA BLACK FT	10
326	029466-099	WIRE, 14 GA WHITE FT	10
327	029460-099	WIRE, 14 GA RED FT	10
328	029825-002	DIODE, 5 AMP, 400V	15
329	029601-013	CONN, RING 16-14 #10	23
330	029610-002	CONN, FORK 16-14 #8	4
331	029616-002	CONN, FEMALE PUSH 16-14	61
332	029490-099	WIRE 16 GAUGE, 2 COND, TYPE SO FT	5

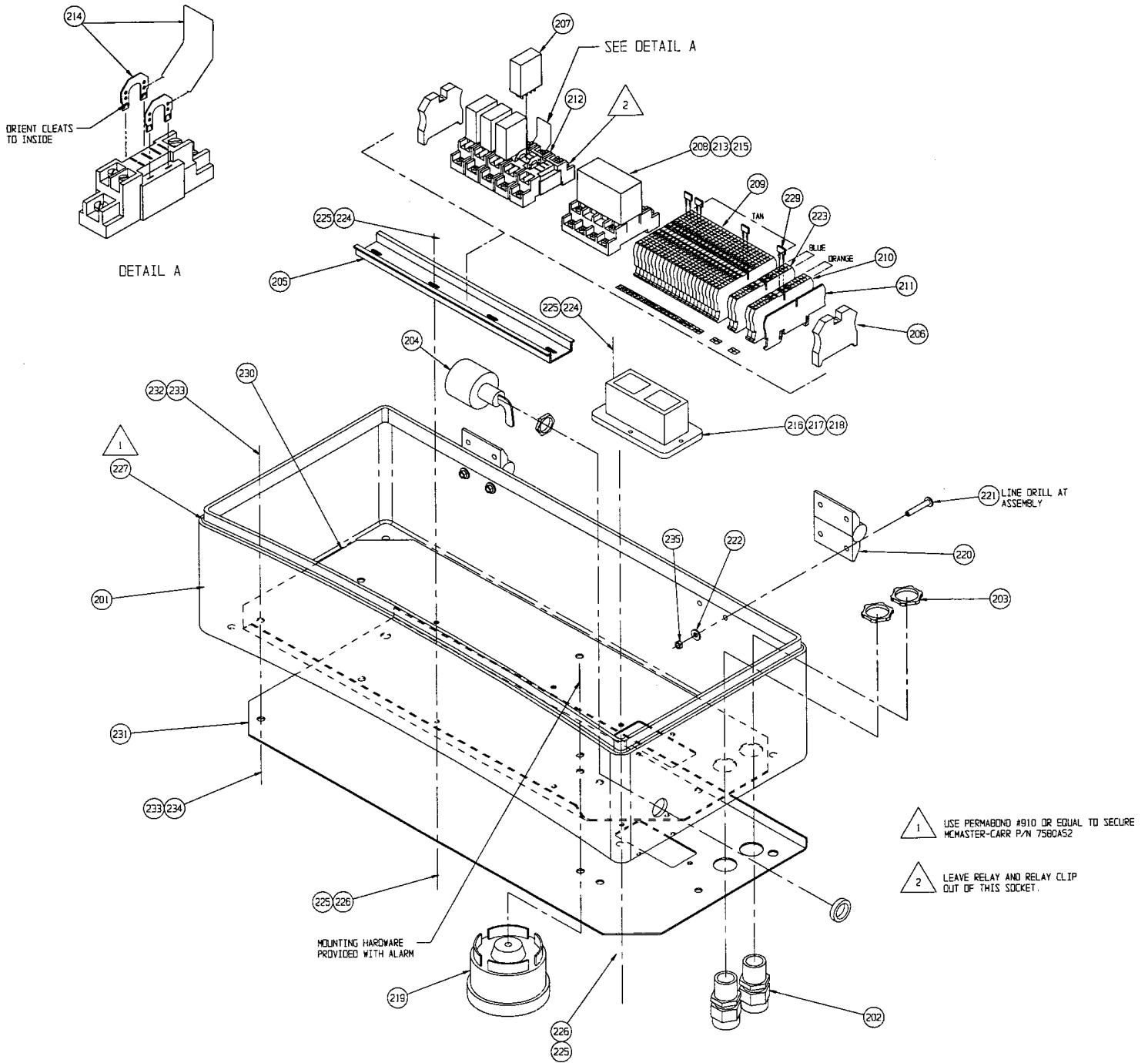
# Illustrated Parts Breakdown

Section  
**6.2**



**UPPER CONTROLLER  
ASSEMBLY, DIESEL  
100016-001  
DRAWING 1 OF 3**

# Illustrated Parts Breakdown



**UPPER CONTROLLER  
ASSEMBLY, DIESEL - DOM  
100016-001  
DRAWING 2 OF 3**



# Illustrated Parts Breakdown

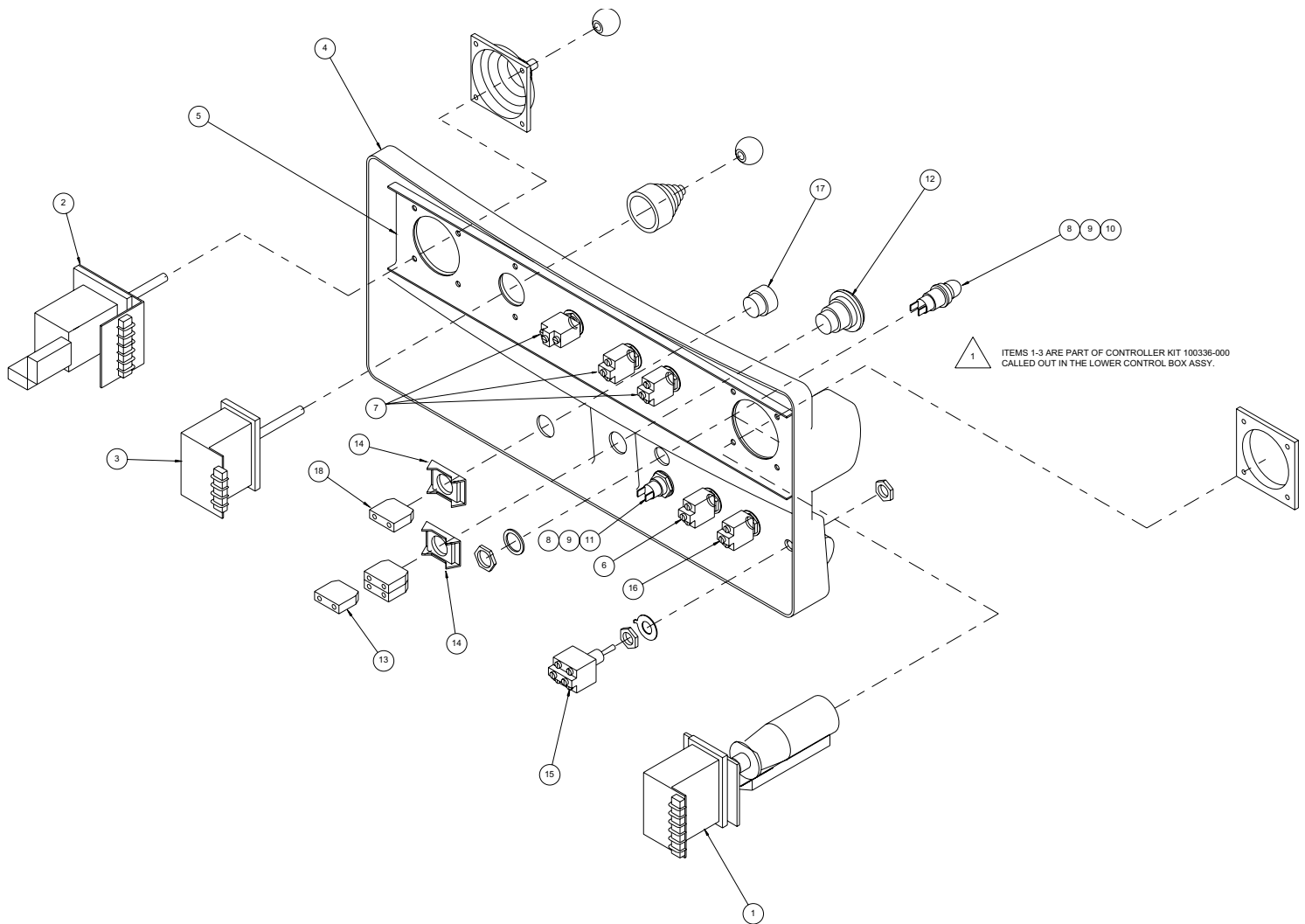
## UPPER CONTROLLER ASSEMBLY GAS SB60 100017-000

ITEM	PART	DESCRIPTION	QTY.
1	100325-000	DRIVE CONTROLLER	1
*	066786-015	BOOT, ROCKER SWITCH	1
*	066786-024	STEERING MICRO SWITCH	1
*	063913-001	BOOT, HANDLE	1
*	068592-008	DRIVE MICRO SWITCH	1
*	066786-011	HANDLE HALF, FRONT	1
*	066786-012	HANDLE HALF, REAR	1
*	066786-013	GASKET, HANDLE	1
*	066786-021	SWITCH, PUSH BUTTON	1
2	100326-000	LIFT CONTROLLER	1
3	100327-000	EXTEND CONTROLLER	1
*	068592-008	DRIVE MICRO SWITCH	1
4	100309-000	UPPER CONTROL BOX	1
5	100310-000	STIFFENER, UPPER CONTROLLER	1
6	012797-000	SWITCH TOGGLE SPST MAINTAINED	1
7	012798-000	SWITCH TOGGLE SPDT MOMENTARY	3
8	068590-000	BASE INDICATOR SPDT MOMENTARY	2
9	068591-001	LAMP T-2 1/2	2
10	068595-002	LENS AMBER	1
11	068595-001	LENS RED	1
12	064446-003	EMERGENCY STOP BUTTON	1
13	064443-002	CONTACT BLOCK NC	3
14	064417-001	FLANGE MOUNT	2
15	012798-005	SWITCH TOGGLE DPST MOMENTARY	1
16	029871-001	SWITCH TOGGLE SPDT MAINTAINED	1
17	067654-000	PUSH BUTTON, FLUSH (BLACK)	1
18	064443-001	CONTACT BLOCK NO	1
201	100309-000	UPPER CONTROL BOX	REF
202	029925-002	CONNECTOR CABLE 1/2 NPT	2
203	029939-002	LOCKNUT 1/2 NPT	2
204	100334-000	SWITCH, LEVER	1
205	067893-000	MOUNTING RAIL DIN X 13 LG	1
206	067660-006	TERMINAL END	2
207	067661-001	RELAY SPDT 12VDC	5
208	067661-004	RELAY 4PDT 12VDC	1
209	068698-001	TERMINAL BLOCK (TAN)	23
210	068698-000	TERMINAL BLOCK (ORANGE)	2
211	068698-004	END CAP, CONTACT BLOCK	1
212	067662-001	RELAY SOCKET SPDT	5
213	067662-004	RELAY SOCKET 4PDT	1
214	067662-005	RETAINER CLIP ASSY	5
215	067662-007	RETAINER CLIP ASSY	1
216	015790-006	CONNECTOR RECEPTACLE	1
217	015790-004	PIN CONTACT 16-18G	27

ITEM	PART	DESCRIPTION	QTY.
218	015790-007	PIN CONTACT 14-16G	3
219	066807-001	ALARM 107DB	1
220	100319-000	HINGE SOUTH CO C6-30	2
221	026553-004	RIVET PDP 3/16 DIA X .375 GRIP	8
222	011240-002	WASHER #8 FLAT	8
223	068698-002	TERMINAL BLOCK (BLUE)	2
224	011715-006	SCREW RD HD MACHINE #6-32 X 3/4 LG	6
225	011240-001	WASHER #6-32	12
226	011248-047	LOCKNUT #6-32	6
227	100337-099	O-RING CORD 3/16	FT 3.5
229	068773-002	JUMPER, 2 PIN	4
230	100707-000	INNER STIFFENER	1
231	100708-000	OUTER STIFFENER	1
232	011252-006	SCREW 1/4-20 UNC HHC X 3/4 LG	1
233	011240-004	WASHER 1/4 FLAT	2
234	011248-004	LOCKNUT 1/4-20 UNC	1
301	029452-099	WIRE, 16 GA BLACK	FT 10
302	029451-099	WIRE, 16 GA WHITE	FT 10
303	029454-099	WIRE, 16 GA RED	FT 10
304	029457-099	WIRE, 16 GA GREEN	FT 10
305	029450-099	WIRE, 16 GA BLUE	FT 10
306	029479-099	WIRE, 16 GA WHITE/BLACK	FT 10
307	029478-099	WIRE, 16 GA RED/BLACK	FT 10
308	005491-000	WIRE, 16 GA GREEN/BLACK	FT 10
309	029351-099	WIRE, 16 GA BLACK/WHITE	FT 10
310	029352-099	WIRE, 16 GA RED/WHITE	FT 10
311	029353-099	WIRE, 16 GA GREEN/WHITE	FT 10
312	029354-099	WIRE, 16 GA BLUE/WHITE	FT 10
313	029355-099	WIRE, 16 GA BLACK/RED	FT 10
314	029358-099	WIRE, 16 GA BLUE/RED	FT 10
315	029356-099	WIRE, 16 GA WHITE/RED	FT 10
316	029360-099	WIRE, 16 GA ORANGE/GREEN	FT 10
317	029456-099	WIRE, 16 GA YELLOW	FT 10
318	029477-099	WIRE, 16 GA ORANGE/BLACK	FT 10
319	029475-099	WIRE, 16 GA BLUE/BLACK	FT 10
320	029359-099	WIRE, 16 GA RED/GREEN	FT 10
321	029455-099	WIRE, 16 GA BROWN	FT 10
322	029362-099	WIRE, 16 GA RED/BLACK/WHITE	FT 10
323	029453-099	WIRE, 16 GA ORANGE	FT 10
324	029488-099	WIRE, 16 GA, 6 COND	FT 11
325	029461-099	WIRE, 14 GA BLACK	FT 10
326	029466-099	WIRE, 14 GA WHITE	FT 10
327	029460-099	WIRE, 14 GA RED	FT 10
328	029825-002	DIODE, 5 AMP, 400V	15
329	029601-013	CONN, RING 16-14 #10	23
330	029610-006	CONN, FORK 16-14 #6	59
331	029616-002	CONN, FEMALE PUSH 16-14	4
332	029490-099	WIRE 16 GAUGE, 2 COND, TYPE SO	FT 5

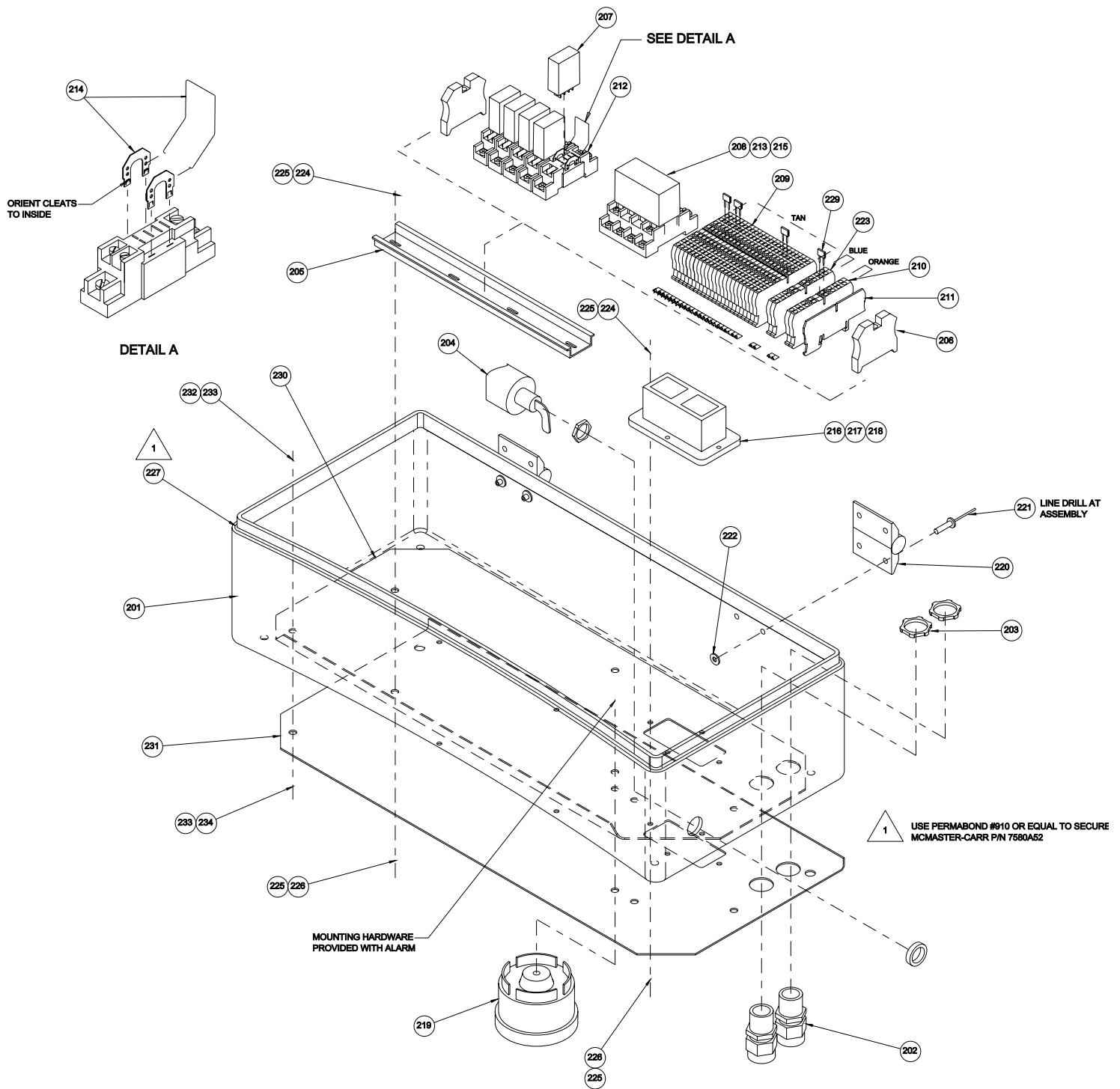
# Illustrated Parts Breakdown

Section  
**6.2**



**UPPER CONTROLLER  
ASSEMBLY, GAS, SB60  
100017-000  
DRAWING 1 OF 3**

# Illustrated Parts Breakdown



**UPPER CONTROLLER  
ASSEMBLY, GAS, SB60  
100017-000  
DRAWING 2 OF 3**





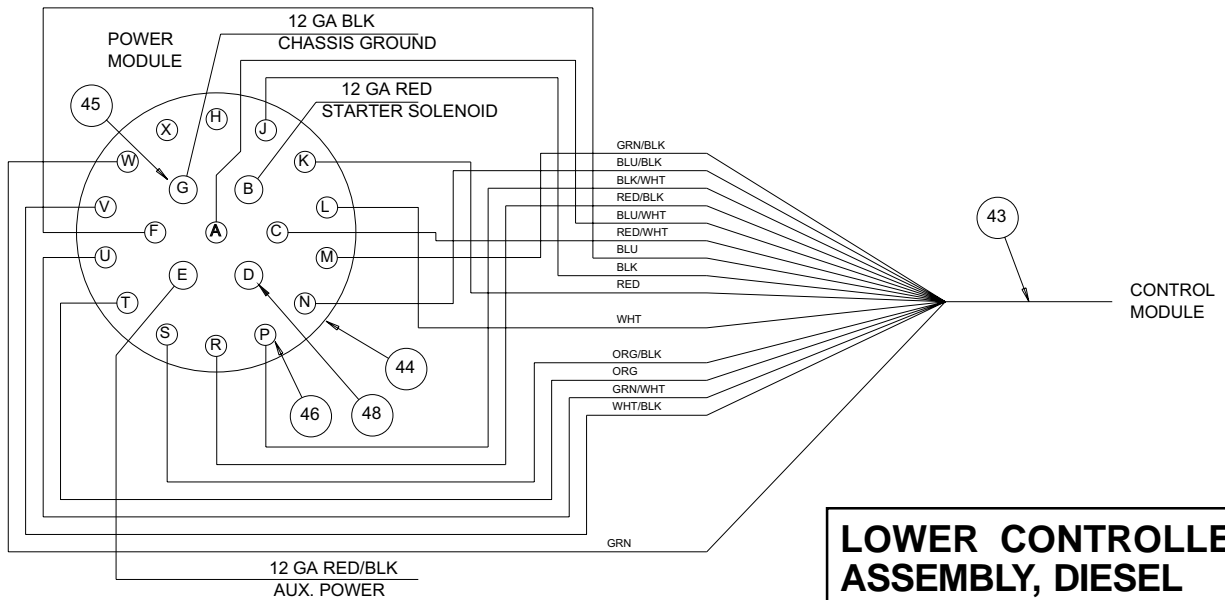
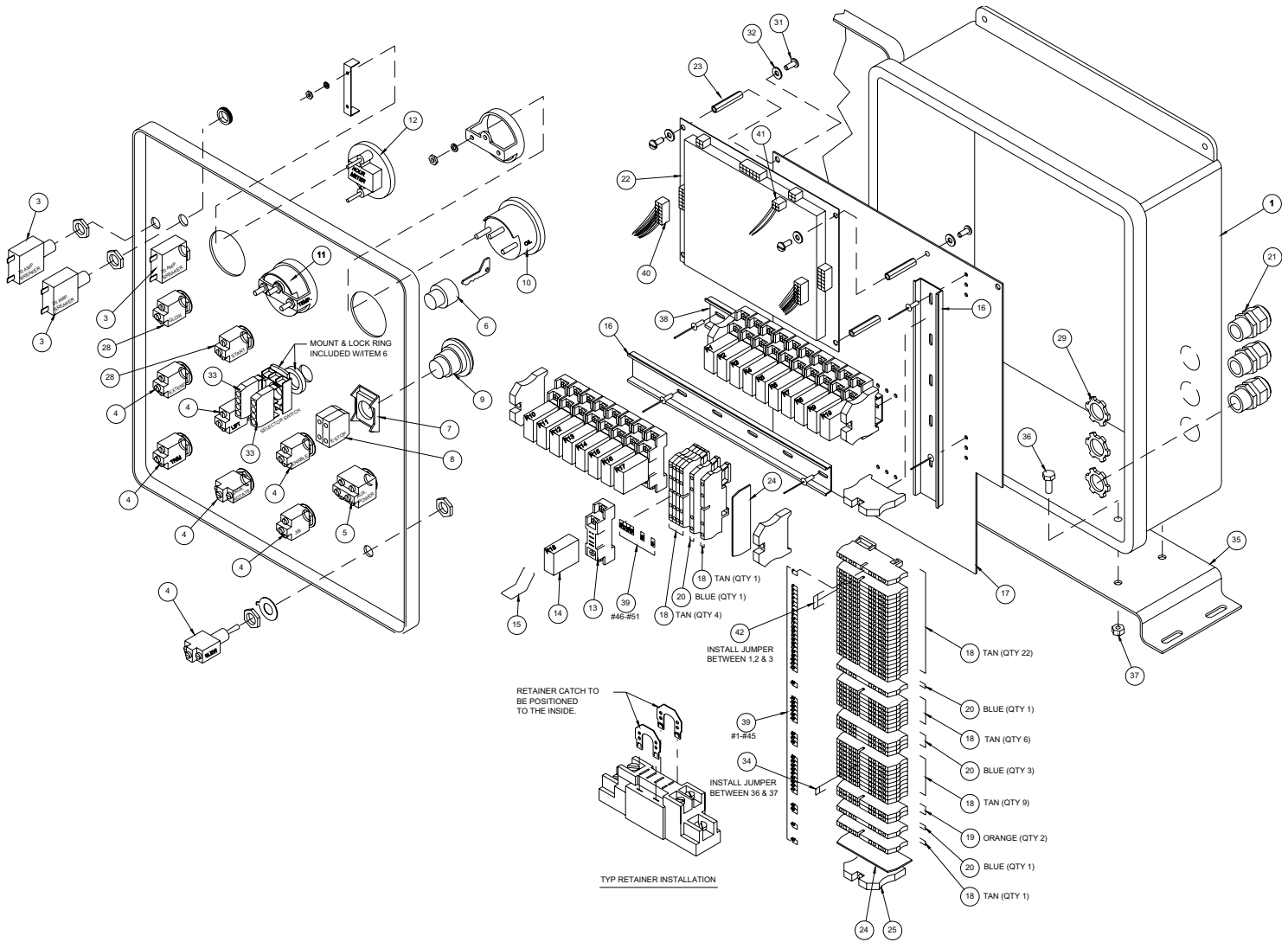
# Illustrated Parts Breakdown

## LOWER CONTROLLER ASSEMBLY DIESEL 100018-000

ITEM	PART	DESCRIPTION	QTY.
1	100307-000	ENCLOSURE	1
3	068582-020	CIRCUIT BREAKER, 20AMP	3
4	012798-000	TOGGLE SWITCH, SPDT	7
5	012798-005	TOGGLE SWITCH, DPDT	1
6	100335-000	SELECTOR SWITCH, KEY OPERATED	1
*	068807-010	KEY	1
7	064417-001	LATCH PLATE	1
8	064443-002	CONTACT BLOCK, NC	2
9	064446-003	OPERATOR, RED "MUSHROOM" BUTTON	1
10	100331-000	OIL PRESSURE GAUGE	1
11	100330-000	TEMPERATURE GAUGE	1
12	015752-000	HOUR METER	1
13	067662-001	BASE, RELAYS SINGLE POLE	17
14	067661-001	RELAY, SINGLE POLE	17
15	067662-005	RETAINER CLIP, RELAY	17
16	067893-005	DIN RAIL 10-1/2" LENGTH	2
17	100316-000	MOUNTING PLATE	1
18	068698-001	TERMINAL BLOCK, TAN	43
19	068698-000	TERMINAL BLOCK, ORANGE	2
20	068698-002	TERMINAL BLOCK, BLUE	6
21	029925-001	CORD GRIP	3
22	100328-000	PROCESSOR	1
23	100299-000	SPACER	3
24	068698-004	END SECTION	2
25	067660-006	END BLOCK, LOCKING	6
26	026551-005	POP RIVET 1/8" DIA (3/16-1/4 GRIP)	6
28	012798-006	TOGGLE SWITCH	2
29	029939-003	LOCKNUT 3/4" NPT	3
31	011708-004	SCR, RD HD #8-32 UNC X 1/2	6
32	011240-003	WASHER, FLAT #10	6
33	068860-000	CONTACT BLOCK, NO DOUBLE	2
34	068773-002	JUMPER, 2 PIN	1
35	100315-000	MOUNTING BRACKET	1
36	011252-006	SCREW, HHC 1/4-20 X 3/4	4
37	011248-004	LOCKNUT, 1/4-20 UNC ESNA	4
38	067893-006	DIN RAIL 8-1/2" LENGTH	1
39	100298-000	NUMBER STRIP #1 - #50	1
40	100336-015	WIRE HARNESS	2
41	100336-016	WIRE HARNESS	1
42	068773-003	JUMPER, 3 PIN	1
43	060214-099	CABLE 16 GA 15 COND	FT 11
44	100338-001	CONNECTOR, FEMALE 21 PIN	1
45	100338-011	CONN, 12 GA PIN	3
46	100338-013	CONN, 16 GA PIN	15
47	100338-005	BOOT	1
48	068764-000	PLUG SEALING	3

ITEM	PART	DESCRIPTION	QTY.
201	029452-099	WIRE, 16 GA BLACK	FT 10
202	029451-099	WIRE, 16 GA WHITE	FT 10
203	029454-099	WIRE, 16 GA RED	FT 10
204	029457-099	WIRE, 16 GA GREEN	FT 10
205	029479-099	WIRE, 16 GA WHITE/BLACK	FT 10
206	029478-099	WIRE, 16 GA RED/BLACK	FT 10
207	005491-099	WIRE, 16 GA GREEN/BLACK	FT 10
208	029477-099	WIRE, 16 GA ORANGE/BLACK	FT 10
209	029352-099	WIRE, 16 GA RED/WHITE	FT 10
210	029353-099	WIRE, 16 GA GREEN/WHITE	FT 10
211	029354-099	WIRE, 16 GA BLUE/WHITE	FT 10
212	029358-099	WIRE, 16 GA BLUE/RED	FT 10
213	029356-099	WIRE, 16 GA WHITE/RED	FT 10
214	029360-099	WIRE, 16 GA ORANGE/GREEN	FT 10
215	029475-099	WIRE, 16 GA BLUE/BLACK	FT 10
216	029453-099	WIRE, 16 GA ORANGE	FT 10
217	029450-099	WIRE, 16 GA BLUE	FT 10
218	029456-099	WIRE, 16 GA YELLOW	FT 10
221	029472-099	WIRE, 12 GA BLACK	FT 10
222	029470-099	WIRE, 12 GA RED	FT 10
223	029466-099	WIRE, 14 GA WHITE	FT 10
224	015747-002	DIODE, 1 - 1-1/2 AMP 1000 VOLT	7
225	029825-003	DIODE, 3 AMP 400 VOLT	23
227	029447-099	CABLE, 3 COND/16 AWG	FT 7
228	100321-099	CABLE, 34 COND/18 GA -3 COND/10 GA	FT 80
229	060214-099	CABLE, 15 COND/16 AWG	FT 10
230	060214-099	CABLE, 15 COND/16 AWG	FT 14
231	029490-099	CABLE, 2 COND/16 AWG	FT 10
232	100380-000	SWITCH, LIFT INTERLOCK	1
233	029620-002	CONN BUTT 16-14 GA	10
234	029601-039	CONN RING (5/16 DIA) 12-10 GA	1
235	029617-003	CONN MALE PUSH (.25) 12-10 GA	2
236	029610-002	CONN FORK (#6 DIA) 16-14 GA	127
237	029610-003	CONN FORK (#6 DIA) 12-10 GA	3
238	029601-012	CONN RING (#8 DIA) 16-14 GA	6
239	029931-003	CONN FEM PUSH (.25) 16-14 GA	2
240	029931-005	CONN FEM PUSH (.25) 12-10 GA	6
241	029610-001	CONN FORK 22-18 GA #6	1

# Illustrated Parts Breakdown



**LOWER CONTROLLER ASSEMBLY, DIESEL**  
**100018-000**  
DRAWING 1 OF 2



**NOTES:**

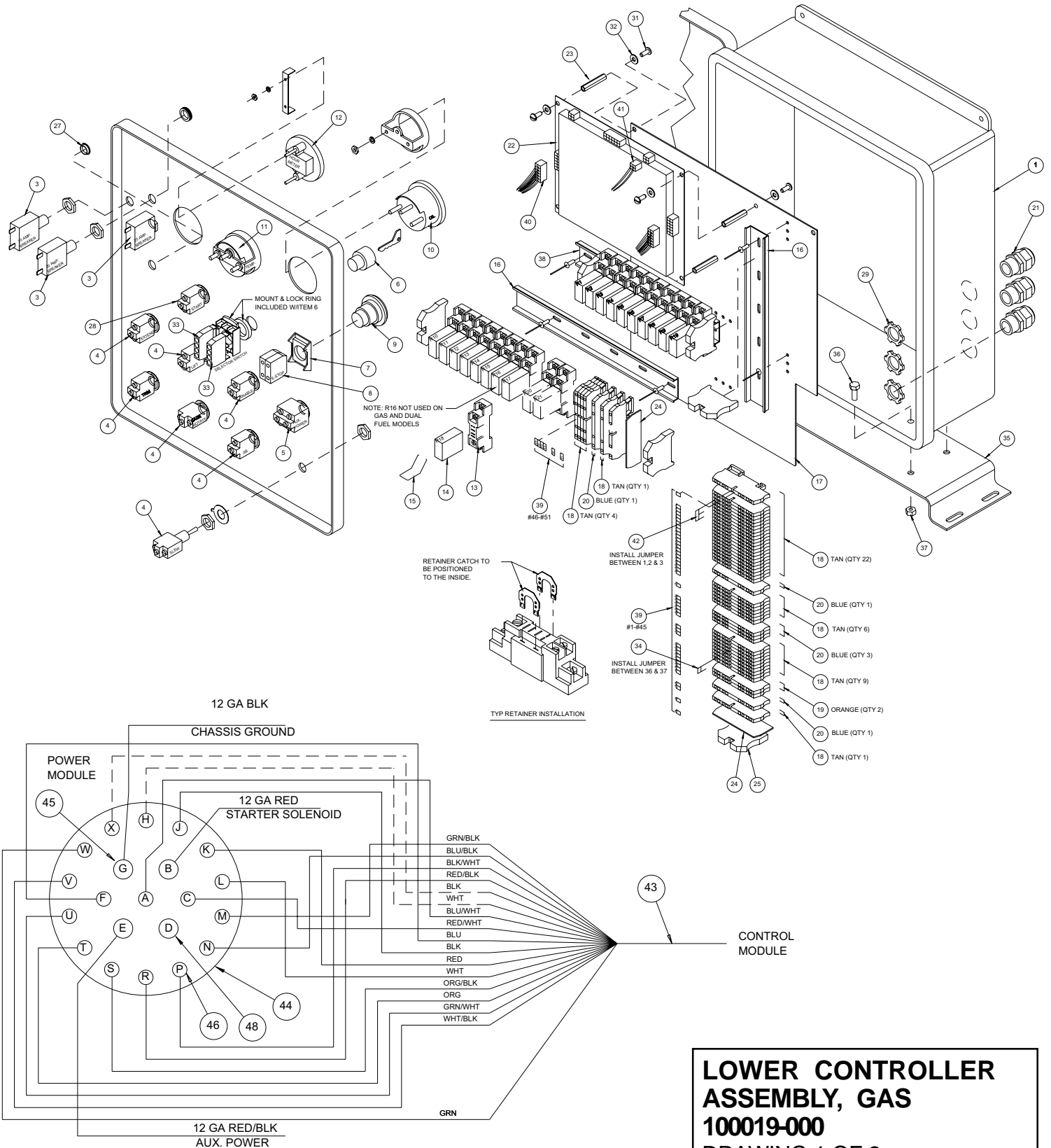
# Illustrated Parts Breakdown

## LOWER CONTROLLER ASSEMBLY, GAS 100019-000

ITEM	PART	DESCRIPTION	QTY.
1	100307-000	ENCLOSURE	1
3	068582-020	CIRCUIT BREAKER, 20AMP	3
4	012798-000	TOGGLE SWITCH, SPDT	7
5	012798-005	TOGGLE SWITCH, DPDT	1
6	100335-000	SELECTOR SWITCH, KEY OPERATED	1
*	068807-010	KEY	1
7	064417-001	LATCH PLATE	1
8	064443-001	CONTACT BLOCK, NC	2
9	064446-003	OPERATOR, RED "MUSHROOM" BUTTON	1
10	100331-000	OIL PRESSURE GAUGE	1
11	100330-000	TEMPERATURE GAUGE	1
12	015752-000	HOUR METER	1
13	067662-001	BASE, RELAY SINGLE POLE	17
14	067661-001	RELAY, SINGLE POLE	17
15	067662-005	RETAINER CLIP, RELAY	17
16	067893-005	DIN RAIL 10-1/2" LENGTH	2
17	100316-000	MOUNTING PLATE	1
18	068698-001	TERMINAL BLOCK, TAN	43
19	068698-000	TERMINAL BLOCK, ORANGE	2
20	068698-002	TERMINAL BLOCK, BLUE	6
21	029925-001	CORD GRIP	3
22	100336-000	CONTROLLER "SUPER-FLEX" KIT	1
23	100299-000	SPACER	3
24	068698-004	END SECTION	2
25	067660-006	END BLOCK, LOCKING	6
26	026551-005	POP RIVET 1/8" DIA (3/16-1/4 GRIP)	6
27	066516-008	PLUG, 1/2" DIA	1
28	012798-006	TOGGLE SWITCH	1
29	029939-003	LOCKNUT 3/4" NPT	3
31	011708-004	SCR, RD HD #8-32 UNC X 1/2	6
32	011240-003	WASHER, FLAT #10	6
33	068860-000	CONTACT BLOCK, NO DOUBLE	2
34	068773-002	JUMPER, 2 PIN	1
35	100315-000	MOUNTING BRACKET	1
36	011252-006	SCREW, HHC 1/4-20 X 3/4	4
37	011248-004	LOCKNUT, 1/4-20 UNC ESNA	4
38	067893-006	DIN RAIL 8-1/2" LENGTH	1
39	100298-000	NUMBER STRIP #1 - #50	1
40	100336-015	WIRE HARNESS	2
41	100316-016	WIRE HARNESS	1
42	068773-003	JUMPER, 3 PIN	1
43	060214-099	CABLE 16 GA 15 COND	FT 11
44	100338-001	CONNECTOR, FEMALE 21 PIN	1
45	100338-011	CONNECTOR, 12 GA PIN	3
46	100338-013	CONNECTOR, 16 GA PIN	15
47	100338-005	BOOT	1
48	068764-000	PLUG SEALING	3

ITEM	PART	DESCRIPTION	QTY.
201	029452-099	WIRE, 16 GA BLACK	FT 10
202	029451-099	WIRE, 16 GA WHITE	FT 10
203	029454-099	WIRE, 16 GA RED	FT 10
204	029457-099	WIRE 16 GA GREEN	FT 10
205	029479-099	WIRE, 16 GA WHITE/BLACK	FT 10
206	029478-099	WIRE, 16 GA RED/BLACK	FT 10
207	005491-099	WIRE, 16 GA GREEN/BLACK	FT 10
208	029477-099	WIRE, 16 GA ORANGE/BLACK	FT 10
209	029352-099	WIRE, 16 GA RED/WHITE	FT 10
210	029353-099	WIRE, 16 GA GREEN/WHITE	FT 10
211	029354-099	WIRE, 16 GA BLUE/WHITE	FT 10
212	029358-099	WIRE, 16 GA BLUE/RED	FT 10
213	029356-099	WIRE, 16 GA WHITE/RED	FT 10
214	029360-099	WIRE, 16 GA ORANGE/GREEN	FT 10
215	029475-099	WIRE, 16 GA BLUE/BLACK	FT 10
216	029453-099	WIRE, 16 GA ORANGE	FT 10
217	029450-099	WIRE, 16 GA BLUE	FT 10
218	029456-099	WIRE, 16 GA YELLOW	FT 10
222	029470-099	WIRE, 12 GA RED	FT 10
223	029466-099	WIRE, 14 GA WHITE	FT 10
224	015747-002	DIODE, 1 - 1-1/2 AMP 1000 VOLT	6
225	029825-003	DIODE, 3 AMP 400 VOLT	23
227	029447-099	CABLE, 3 COND/16 AWG	FT 7
228	100321-099	CABLE, 34 COND/18 GA -3 COND/10 GA	FT 80
229	060214-099	CABLE, 15 COND/16 AWG	FT 10
230	060214-099	CABLE, 15 COND/16 AWG	FT 14
231	029490-099	CABLE, 2 COND/16 AWG	FT 10
232	100380-000	SWITCH, LIFT INTERLOCK	1
233	029620-002	CONN BUTT 16-14 GA	10
234	029601-039	CONN RING (5/16 DIA) 12-10 GA	1
235	029617-003	CONN MALE PUSH (.25) 12-10 GA	2
236	029610-002	CONN FORK (#6 DIA) 16-14 GA	127
237	029610-003	CONN FORK (#6 DIA) 12-10 GA	3
238	029601-012	CONN RING (#8 DIA) 16-14 GA	6
239	029931-003	CONN FEM PUSH (.25) 16-14 GA	2
240	029931-005	CONN FEM PUSH (.25) 12-10 GA	6
241	029610-001	CONN FORK 22-18 GA #6	1
242	029601-019	CONN T&B RC 367 12 GA RING	1

# Illustrated Parts Breakdown



**LOWER CONTROLLER ASSEMBLY, GAS**  
**100019-000**  
DRAWING 1 OF 2





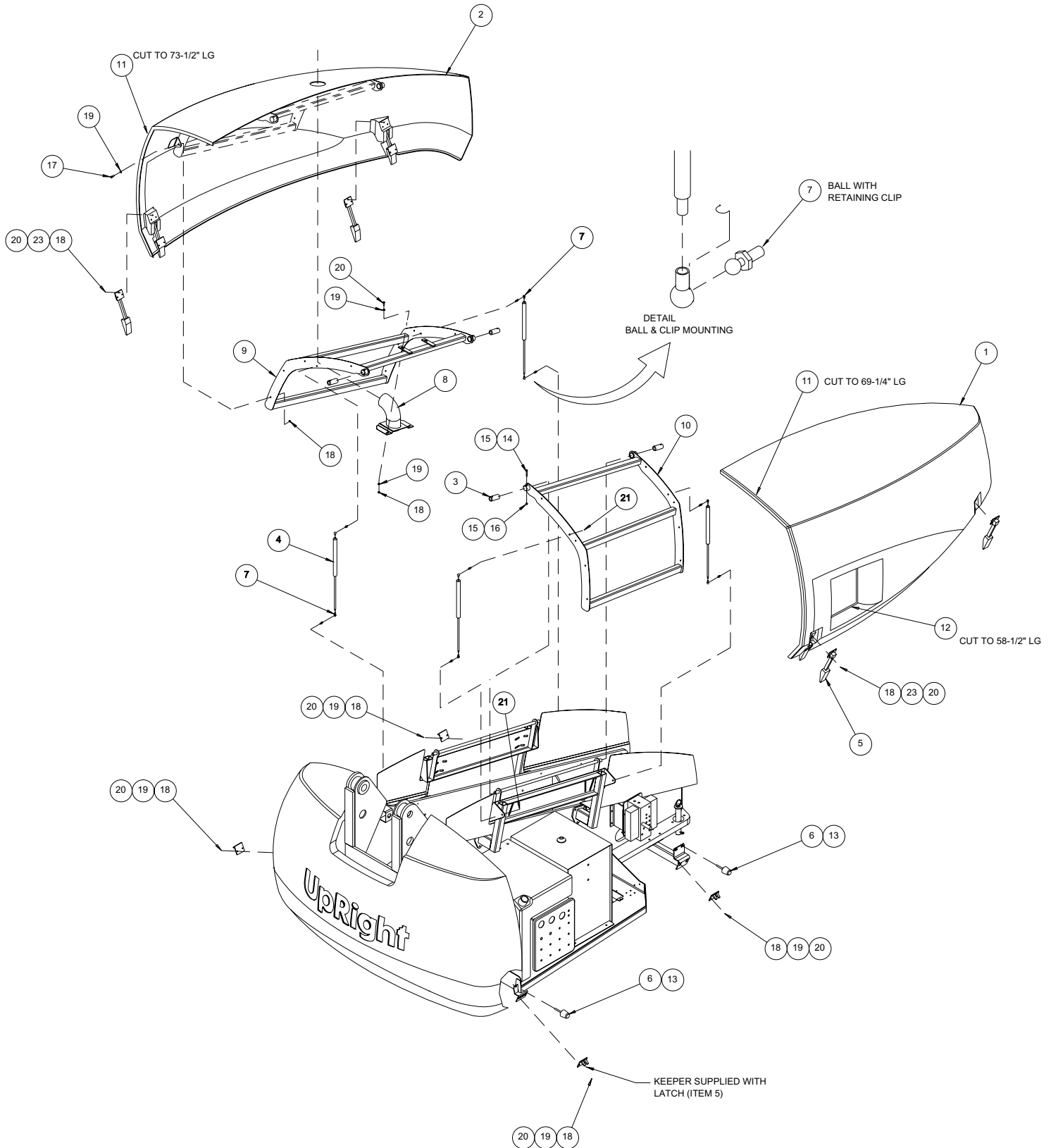
**NOTES:**

## COVER INSTALLATION

100308-000

ITEM	PART	DESCRIPTION	QTY.
1	100130-000	COVER, TURRET LEFT	1
2	100131-000	COVER, TURRET RIGHT	1
3	100368-000	BEARING, HINGE	4
4	100126-000	GASSPRING	4
5	100127-000	LATCH, COVER	4
6	100128-000	BUMPER, RUBBER	4
7	100119-000	BALL STUD 13MM - WITH SAFETY CLIP	8
8	100144-000	EXHAUST PIPE WELDMENT	1
9	100350-000	COVER RIB WELDMENT	1
10	100353-000	COVER RIB WELDMENT	1
11	100370-099	DOOR SEAL "C" FT	12
12	100383-099	DOOR SEAL "B" FT	6
13	011273-006	NUT 3/8 JAM	8
14	011253-018	SCREW, HHC 5/16-18 UNC X 2-1/4	4
15	014996-005	WASHER 5/16 SAE FLAT	16
16	011248-005	NUT 5/16-18 ESNA	4
17	011252-006	SCREW HHC 1/4-20 UNC X 3/4 LG	16
18	011248-004	NUT 1/4 ESNA	38
19	014996-004	WASHER 1/4 SAE FLAT	36
20	011252-008	SCREW HHC 1/4-20 UNC X 1 LG	22
21	011238-005	WASHER 5/16 LOCK	8
23	011240-004	WASHER 1/4 FLAT	12

# Illustrated Parts Breakdown

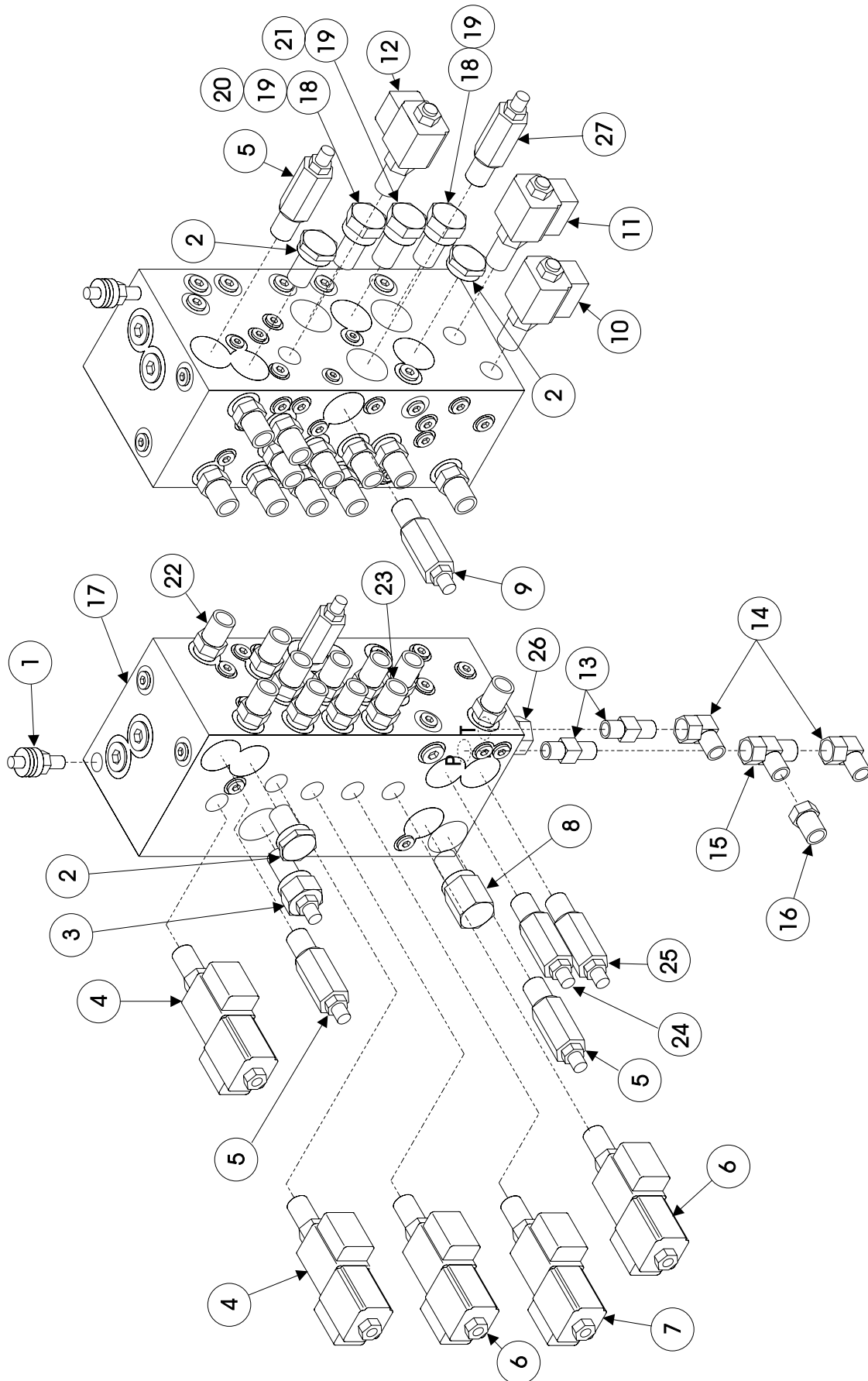


## VALVE BLOCK ASSEMBLY, MAIN

100264-000

ITEM	PART	DESCRIPTION	QTY.
1	063965-001	FITTINGTEST	1
2	100245-010	CHECKVALVE (30PSI)	3
3	100245-014	FLOW CONTROL VALVE	1
4	100245-008	3/4 WAY SOLENOID VALVE (CLOSEDCENTER)	1
5	100245-027	RELIEFVALVE	2
6	100245-007	3/4 WAY PROP. DIR. VALVE (FLOATINGCENTER)	2
7	100245-030	3/4 WAY PROP. DIR. VALVE (CLOSEDCENTER)	1
8	100245-004	DIVERTER VALVE	1
9	100245-026	RELIEFVALVE	1
10	100245-012	2/2 WAY SOLENOID VALVE N/O	1
11	100245-002	2/2 WAY SOLENOID VALVE N/O	1
12	100245-013	2/2 WAY SOLENOID VALVE N/C	1
13	011941-010	FITTING 8MB-8MJ ST	2
14	011937-004	FITTING 8FJ-8MJ 90°	2
15	020733-003	FITTING 8FJ-8MJ-8MJ	1
16	014693-004	FITTING 8FJ-6MJ ST	1
17	100245-001	VALVE BLOCK, STERLING #9S000501-E	1
18	100245-005	DIVERTER VALVE	1
19	100245-023	ORIFICE PLUG	6
20	100245-017	ORIFICE PLUG	1
21	100245-016	COMPENSATOR	1
22	011941-004	FITTING 6MB-4MJ	1
23	011941-005	FITTING 6MB-6MJ	10
24	100245-028	RELIEFVALVE	1
25	100245-024	RELIEFVALVE	1
26	100245-011	SHUTTLEVALVE	1
27	100245-025	RELIEFVALVE	1

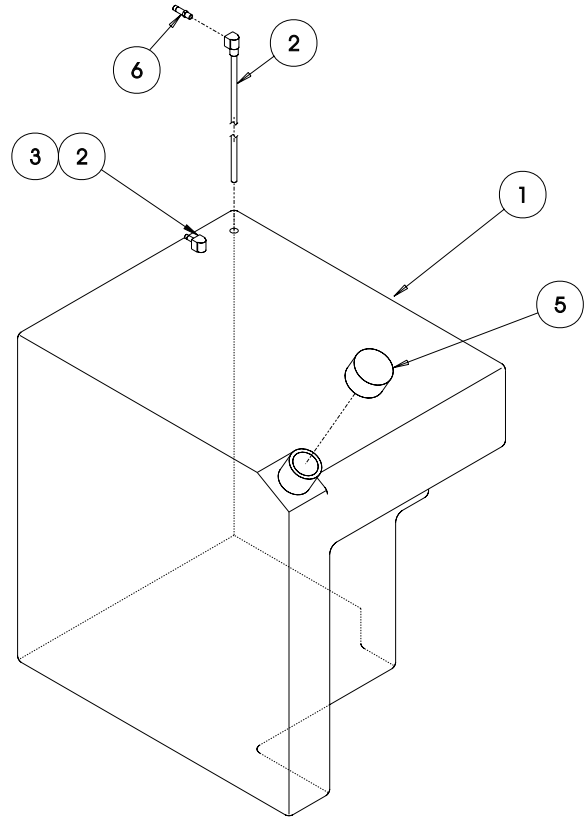
# Illustrated Parts Breakdown



## FUEL TANK ASSEMBLY, DIESEL

100270-000

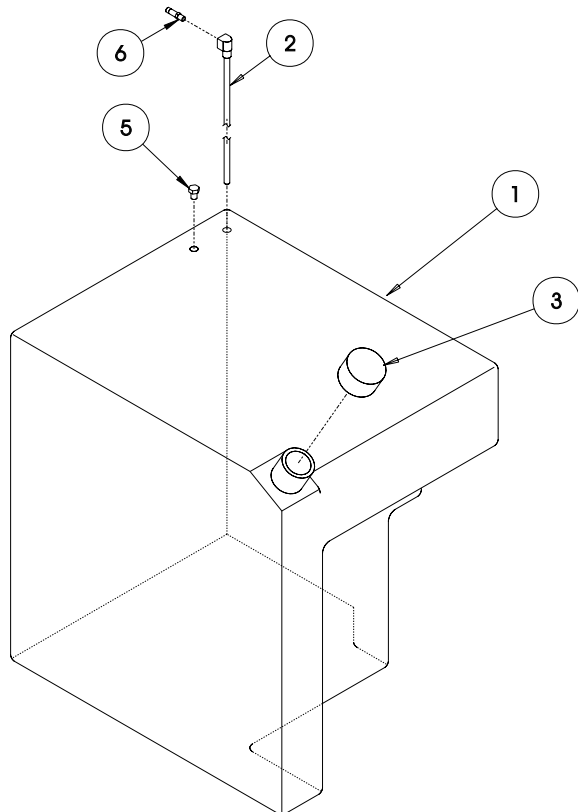
ITEM	PART	DESCRIPTION	QTY.
1	100250-000	FUEL TANK, PLASTIC	1
2	100272-000	WITHDRAWL TUBE	2
3	010178-003	FITTING 1/4 NPT TO 1/4 BARBED	1
5	068982-002	FILLER CAP	1
6	010178-005	FITTING 1/4 NPT TO 5/16 BARBED	1



## FUEL TANK ASSEMBLY, GAS

100270-001

ITEM	PART	DESCRIPTION	QTY.
1	100250-000	FUEL TANK, PLASTIC	1
2	100272-000	WITHDRAWL TUBE	1
3	068982-002	FILLER CAP	1
5	011919-002	PIPE PLUG 1/4 NPT	1
6	010178-003	FITTING 1/4 NPT TO 1/4 BARBED	1

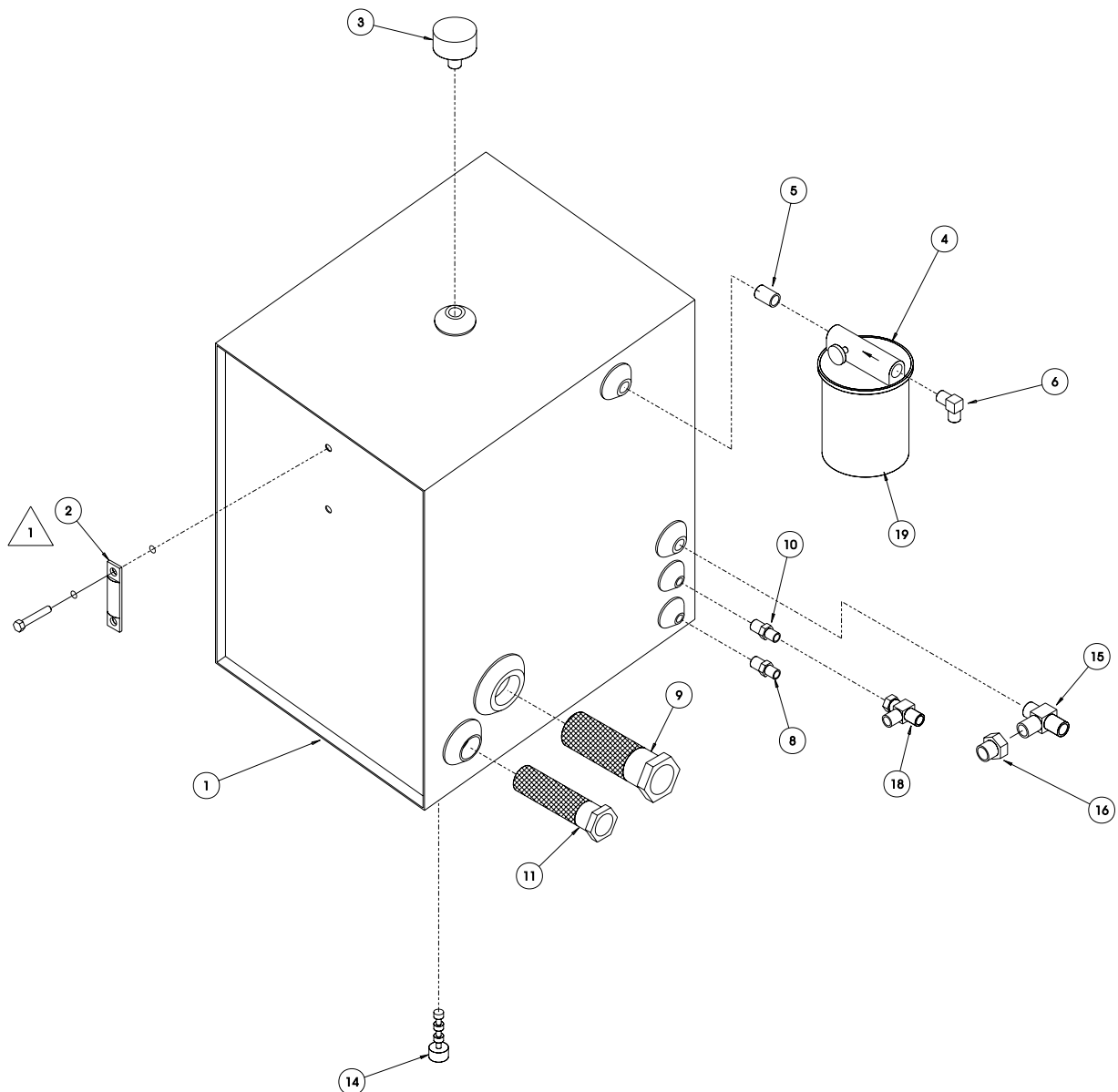


# Illustrated Parts Breakdown

## HYDRAULIC RESERVOIR ASSEMBLY

100271-000

ITEM	PART	DESCRIPTION	QTY.
1	100251-000	HYDRAULIC RESERVOIR	1
2	100287-000	SIGHT GAUGE	1
3	063930-001	FILLER/BREATHER	1
4	100285-000	FILTER	1
5	012467-003	PIPE NIPPLE 3/4 NPT	1
6	011940-018	FITTING 12MP-8MJ 90°	1
8	011939-015	FITTING STR 8MP-8MJ	1
9	100286-001	SUCTION STRAINER	1
10	011939-013	FITTING STR 8MP-4MJ	1
11	100286-000	SUCTION STRAINER	1
14	100288-000	DRAIN PLUG, 3/4 MAGNETIC	1
15	011928-009	FITTING TEE 12MP-10MJ-10MJ	1
16	001369-003	FITTING ADA 10FJ-8MJ	1
18	020733-001	FITTING TEE 4FJ-4MJ-4MJ	1
19	100285-010	FILTER ELEMENT	1



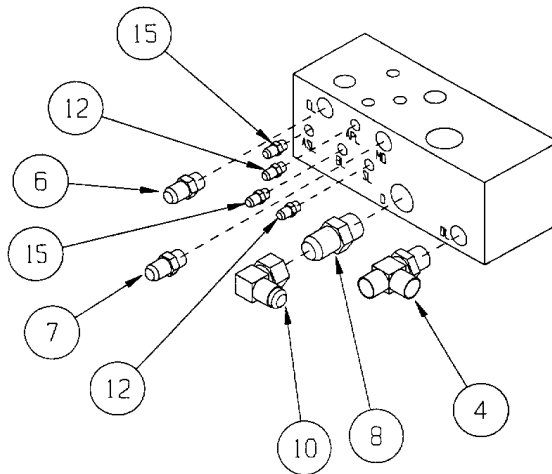
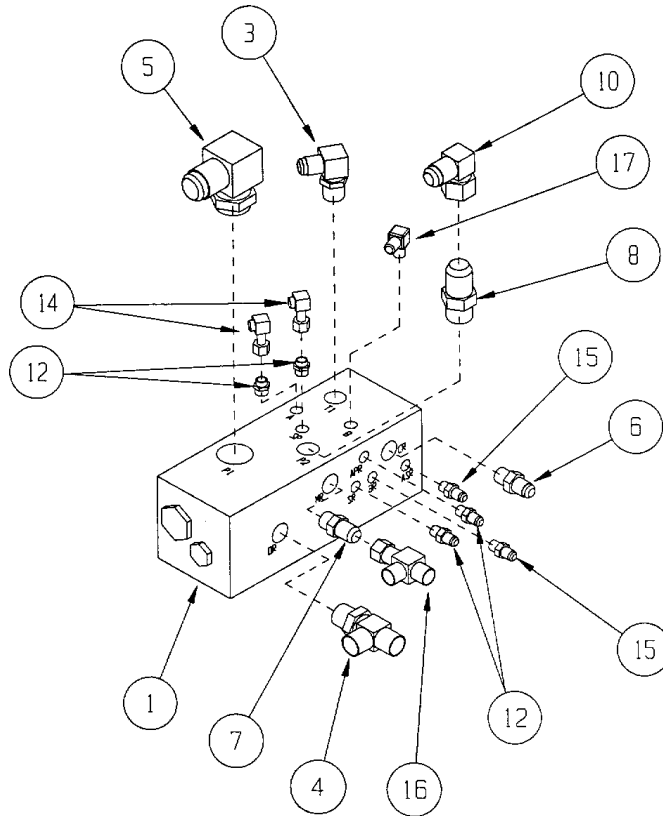
# Illustrated Parts Breakdown

## DIFFERENTIAL LOCK (VALVE BLOCK ASSEMBLY)

100317-000

ITEM	PART	DESCRIPTION	QTY.
1	100282-000	DIFF-LOCK VALVE BLOCK	1
3	011934-013	FITTING, 90° ADAPTER 12MB-8MJ	1
4	100444-004	FITTING, TEE 8MFFOR-8MB-8MFFOR	2
5	100434-023	FITTING, 90° ADAPTER 12MFFOR-16MB	1
6	011941-010	FITTING, STR. ADAPTER 8MB-8MJ	2
7	100432-015	FITTING, STR. ADAPTER 8MFFOR-8MB	2
8	100432-027	FITTING, STR. ADAPTER 12MFFOR-12MB	2

ITEM	PART	DESCRIPTION	QTY.
10	100435-005	FITTING, 12MFFORS-12FFORS 90°	2
11	100433-001	FITTING, 45° 4MFFOR-4MB	1
12	100432-002	FITTING, STR. 4MFFOR-4MB	6
14	100435-001	FITTING, 4MFFORS-4FFORS 90°	2
15	011941-001	FITTING STR. ADAPTER 4MB-4MJ	4
16	100448-002	FITTING, TEE FF2114T-0808S	1
17	011934-001	FITTING 90° ADAPTER 4MB-4MJ	1





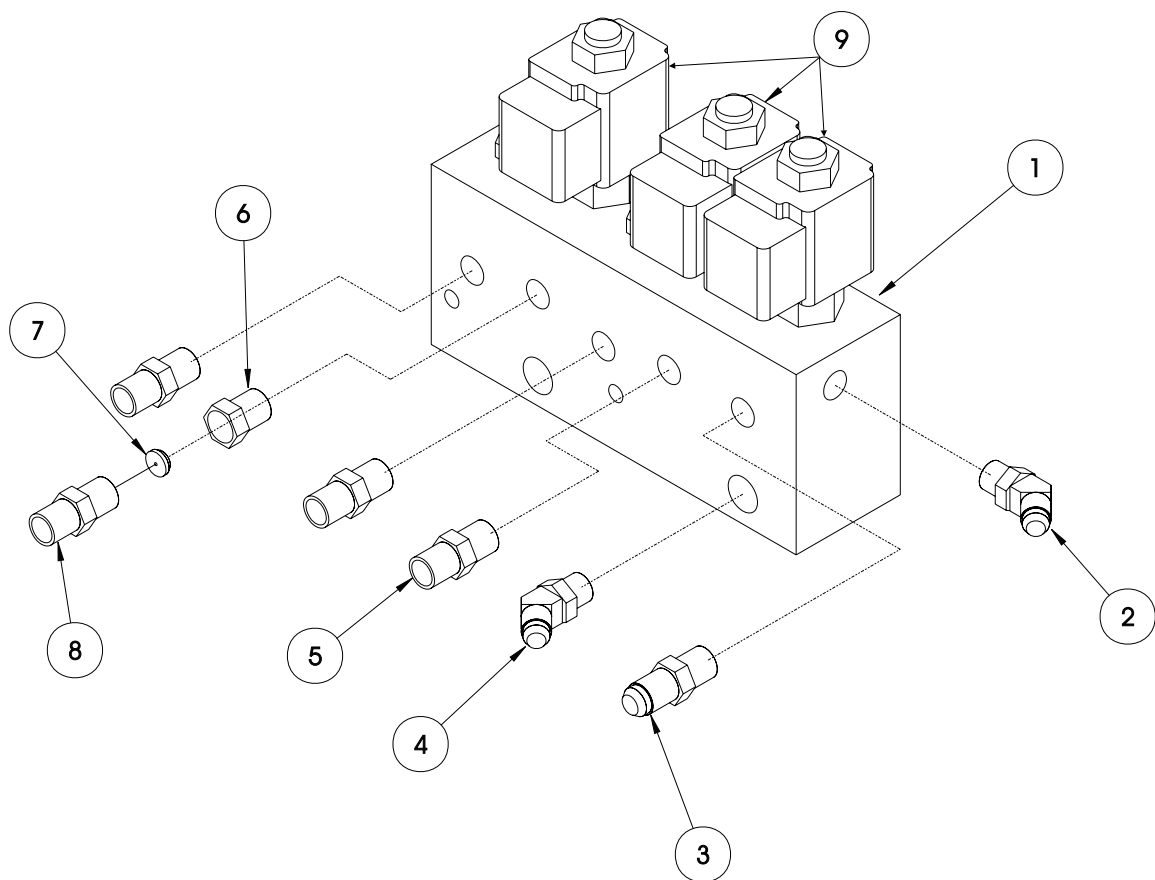
# Illustrated Parts Breakdown

## BRAKE, AXLE LOCK, 2-SPEED (VALVE BLOCK ASSEMBLY)

100323-000

ITEM	PART	DESCRIPTION	QTY.
1	100258-001	VALVE BLOCK, BRAKE, AXLE LOCK, 2-SPEED	1
2	011935-001	FITTING, 45° ADAPTER, 4MB-4MJ	1
3	011941-002	FITTING, STR., ADAPTER 4MB-6MJ	1
4	011935-013	FITTING, 45°, ADAPTER, 6MP-4MJ	1
5	100432-002	FITTING, STR., ADAPTER, 4MFFOR-4MB	3
6	015717-015	FITTING, STR., ADAPTER, 6FB-4MB	1
7	063664-007	ORIFICE, Ø .043	1
8	100432-004	FITTING, STR., ADAPTER, 4MFFOR-6MB	1

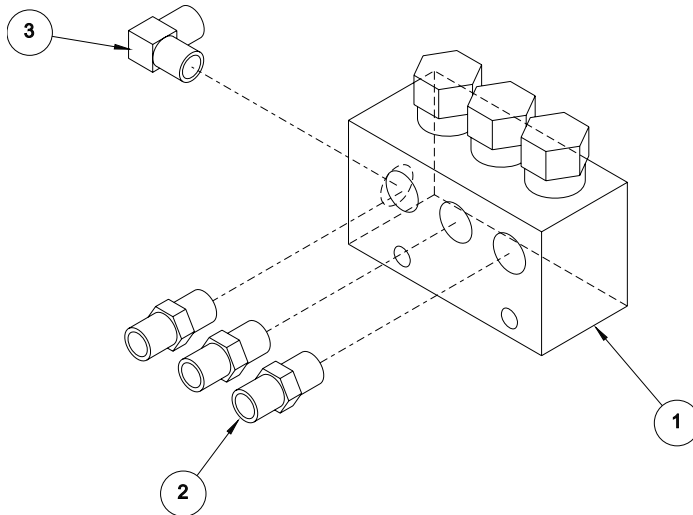
NOTE: ORIENT 63664-007 ORIFICE WITH CHAMFER  
TOWARD VALVE BLOCK.



## FRONT DRIVE CHECK VALVES (VALVE BLOCK ASSEMBLY)

100716-000

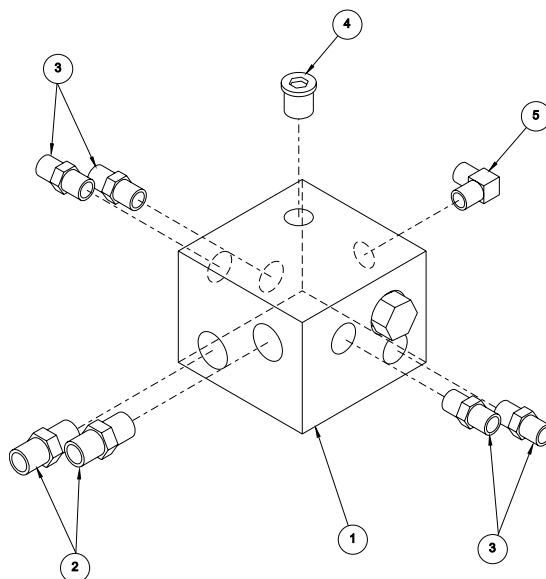
ITEM	PART	DESCRIPTION	QTY.
1	100713-000	VALVE BLOCK, ANTI-CAV CHECK	1
2	100432-015	FITTING 8MB-8MFFOR STRAIGHT	3
3	011934-007	FITTING 8MB-6MJ 90° ELBOW	1



## REAR DRIVE CHECK VALVES (VALVE BLOCK ASSEMBLY)

100717-000

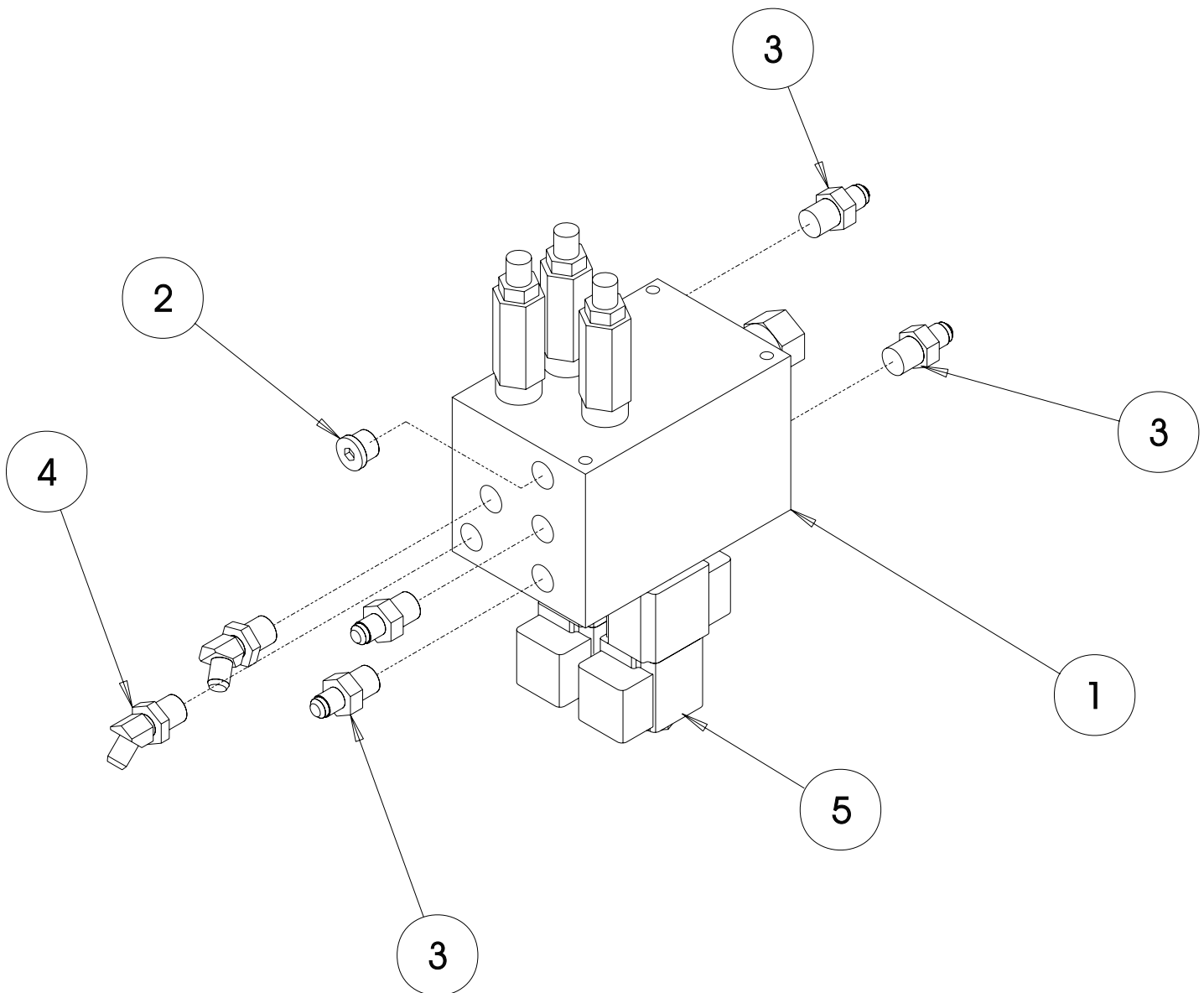
ITEM	PART	DESCRIPTION	QTY.
1	100714-000	VALVE BLOCK, 2 STATION CHECK	1
2	100432-027	FITTING 12MB-12MFFOR STRAIGHT	2
3	100432-016	FITTING 10MB-8MFFOR STRAIGHT	4
4	020021-008	FITTING 8MB PLUG	1
5	011934-007	FITTING 8MB-6MJ 90° ELBOW	1



# Illustrated Parts Breakdown

## JIB BOOM (VALVE BLOCK ASSEMBLY) 100283-001

ITEM	PART	DESCRIPTION	QTY.
1	100283-000	VALVE BLOCK, SH #9S002011-A	1
2	012004-006	PLUG, HOLLOW HEX #6 SAE	1
3	011941-004	FITTING, STR. ADAPTOR 6MB-4MJ	4
4	011935-013	FITTING, 45° 6MB-4MJ	2
5	100283-011	COIL, SOLENOID	2

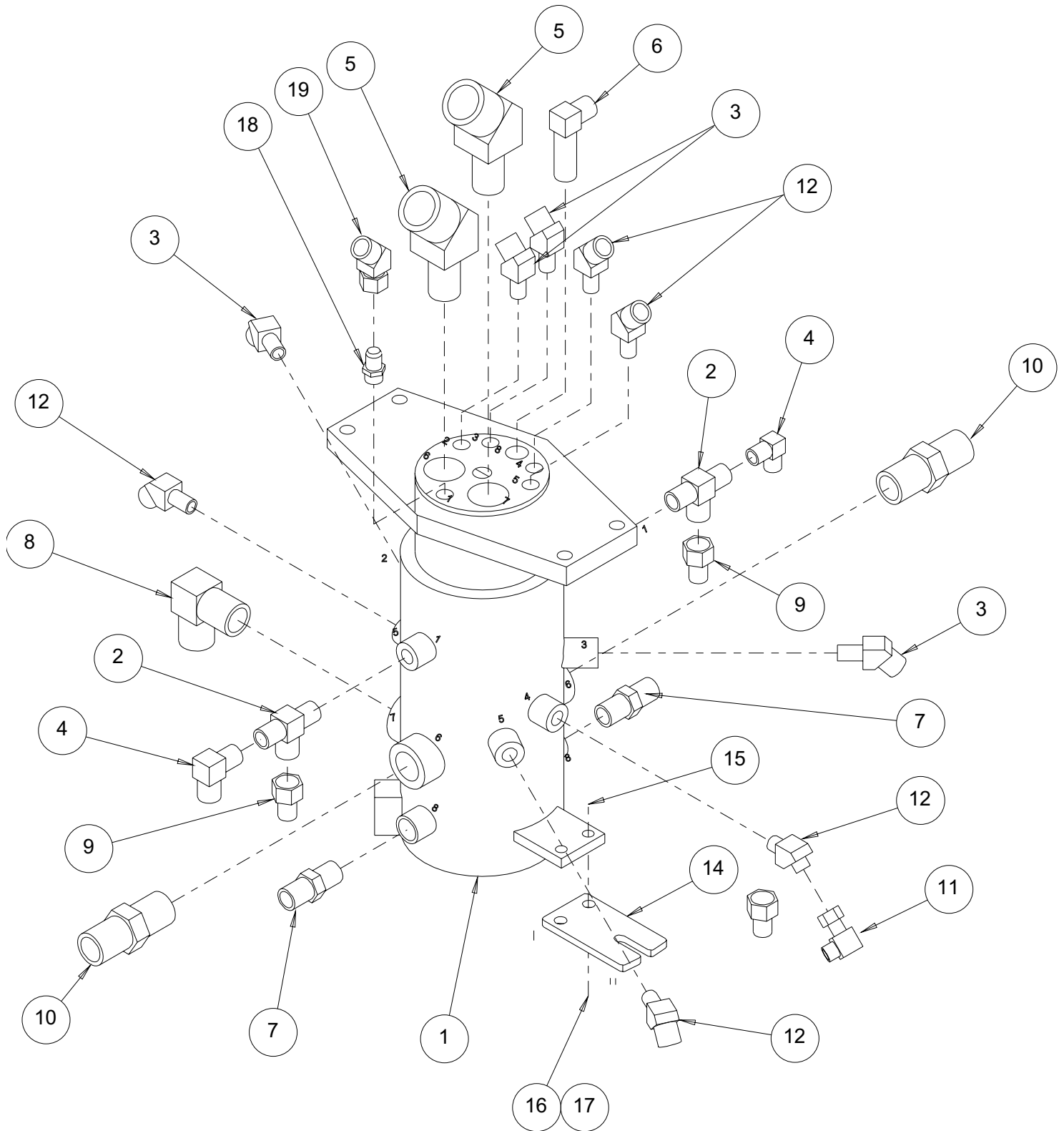


## ROTARY MANIFOLD ASSEMBLY

100190-000

ITEM	PART	DESCRIPTION	QTY.
1	100558-000	ROTARY MANIFOLD	1
2	015961-006	FITTING 6MJ-6MB TEE	2
3	011935-003	FITTING 6MB-6MJ 45° ELBOW	4
4	011937-003	FITTING 6MJ-6FJX 90° ELBOW	2
5	100433-016	FITTING 12MFFOR-16MB 45° ELBOW	2
6	015736-003	FITTING 8MB-8MJ 90° ELBOW	1
7	011941-010	FITTING 8MB-8MJ STRAIGHT	2
8	100434-023	FITTING 12MFFOR-16MB 90°	1
9	014693-001	FITTING 6FJX-4MJ STRAIGHT	2
10	100432-027	FITTING 12MB-12MFFOR STRAIGHT	2
11	100435-001	FITTING 4MFFOR -90°	1
12	100433-002	FITTING 4MFFOR-6MB 45°	5
14	100382-000	TORQUE ARM	1
15	011253-008	SCREW HHC 5/16-18 UNC X 1 LG	2
16	011238-005	WASHER 5/16 LOCK	2
17	011248-005	NUT 5/16-18 ESNA	2
18	011941-005	FITTING STR 6MB-6MJ	1
19	011932-003	FITTING STR 6MB-6MJ	1

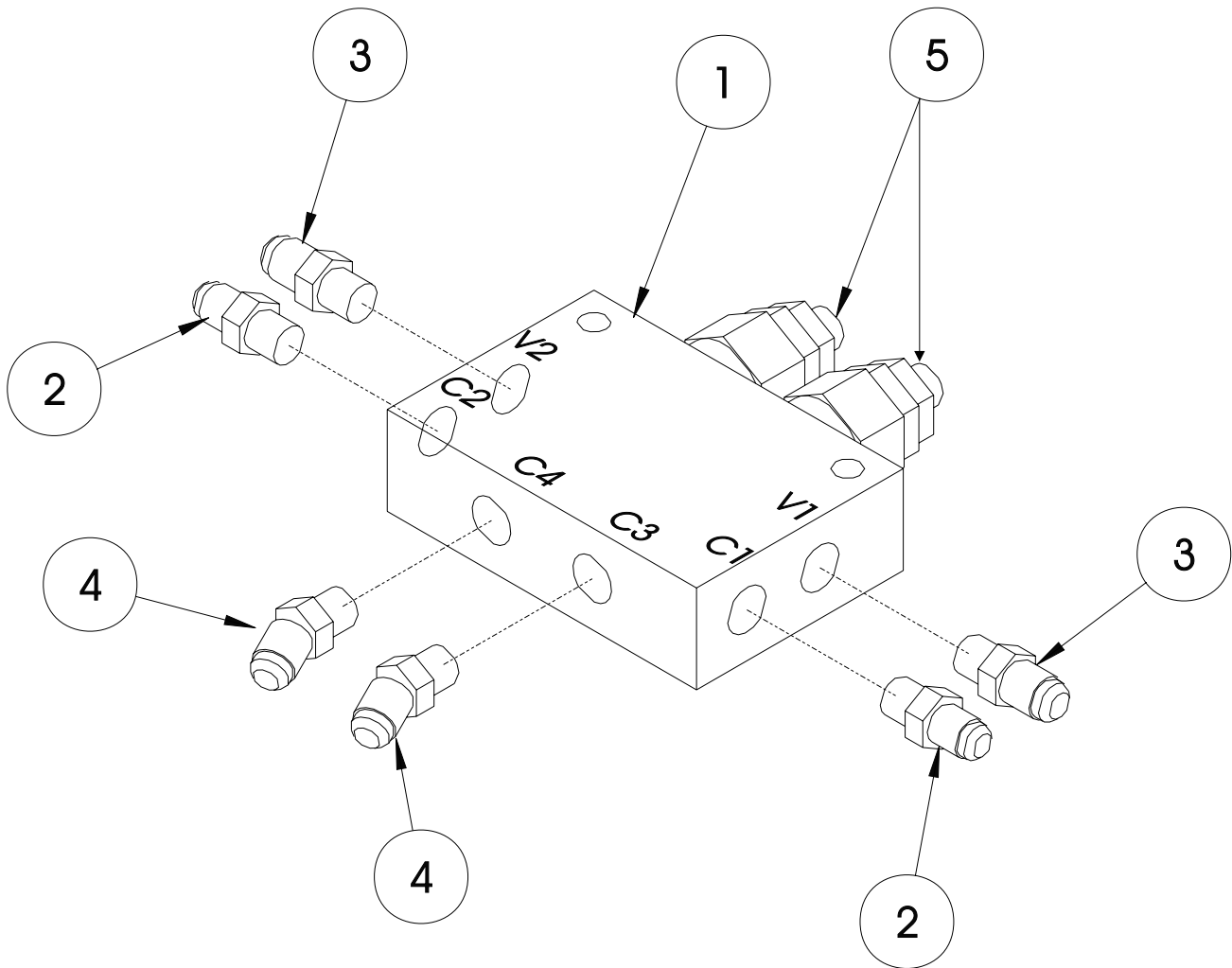
# Illustrated Parts Breakdown



## MOTION CONTROL MASTER CYLINDER (VALVE BLOCK ASSEMBLY)

100269-001

ITEM	PART	DESCRIPTION	QTY.
1	100269-000	VALVE BLOCK, STERLING #9S000520-A	1
2	011941-001	FITTING, STR. ADAPTER 4MB-4MJ	2
3	011941-002	FITTING, STR. ADAPTER 4MB-4MJ	2
4	011935-001	FITTING 45° 4MB-4MJ	2
5	068778-000	VALVE, COUNTERBALANCE	2

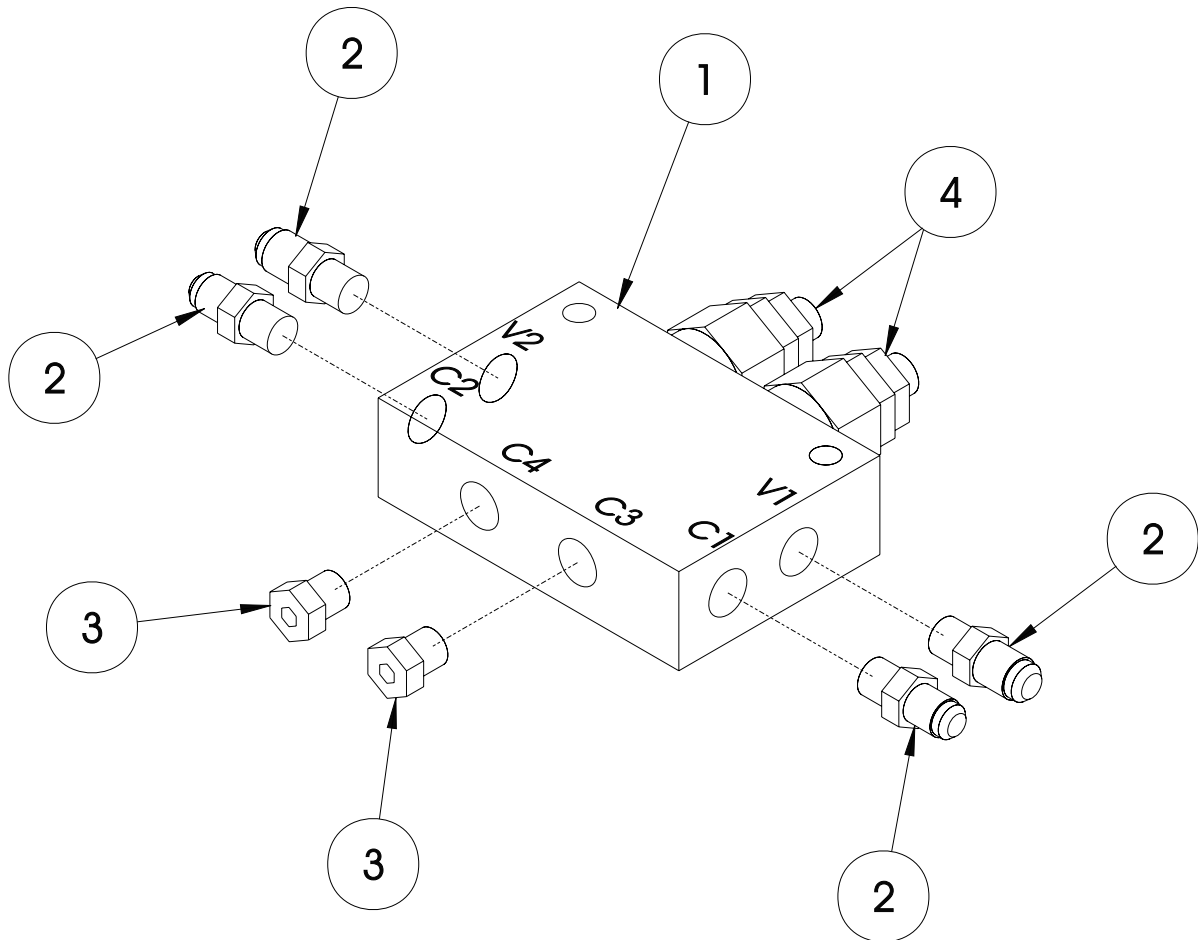


# Illustrated Parts Breakdown

## MOTION CONTROL PLATFORM ROTATE (VALVE BLOCK ASSEMBLY)

100269-002

ITEM	PART	DESCRIPTION	QTY.
1	100269-000	VALVE BLOCK, STERLING #9S000520-A	1
2	011941-001	FITTING, STR. ADAPTER 4MB-4MJ	4
3	020021-004	FITTING, PLUG 4MB	2
4	068778-000	VALVE, COUNTERBALANCE	2



## LABEL KIT

100024-000-DIESEL

100024-001-GAS

ITEM	PART	DESCRIPTION	QTY.
1	061205-002	NAME PLATE/BOOM	1
2	065368-000	TACK	4
5	066552-000	LABEL WARNING EXPLOSIVE GAS	2
6	005221-000	LABEL BATTERY LEVEL	2
7	066555-001	LABEL, CAUTION DO NOT ADJUST	2
8	066556-000	LABEL, CAUTION DESCENDING PLATFORM	2
9	066553-001	LABEL PINCH POINT	4
10	060197-000	LABEL HYDRAULIC FLUID	1
11	027898-001	LABEL DIESEL FUEL	1
12	064166-000	LABEL, GASOLINE-UNLEADED	1
13	010076-001	LABEL ATTENTION	1
14	010076-000	MANUAL CASE	1
15	100028-000	USER MANUAL	1
16	060565-000	ANSI MANUAL	1
17	011248-004	NUT HEX ESNA 1/4-20 UNC	4
18	011252-008	SCREW HHC X 1/4-20 X 1	4
19	062557-012	MAX LOAD 500 LB/225 KG	1
20	064199-001	LABEL 4WD	1
21	068639-000	LABEL, POWER TO PLATFORM	1
22	064444-000	LABEL USA	1
23	066554-000	LABEL BEFORE OPERATION	3
24	068979-000	LABEL, CHOCK WHEELS	4
25	100340-000	LABEL UPPER CONTROLS-DRIVE	1
26	100340-001	LABEL UPPER CONTROLS-AUX. GAS	1
	100340-004	LABEL UPPER CONTROLS-AUX. DSL	1
27	100340-002	LABEL UPPER CONTROLS-EMERGENCY STOP	1
28	100340-003	LABEL UPPER CONTROLS-AUX.	1
29	100341-000	LABEL, LOWER CONTROLS	1
30	066562-005	LABEL, TIRE PRESSURE	4
32	068632-000	LABEL HOLD DOWN	6
33	100345-000	LABEL READ & UNDERSTAND	1
34	068635-000	LABEL HARNESS POINT	2
35	068637-000	LABEL ARROW YELLOW	2
36	068637-001	LABEL ARROW ORANGE	2
37	066553-004	LABEL PINCH POINT	4
40	062814-000	LABEL INSERT PIN	1
41	100346-000	LABEL WARNING SHEARING	2
42	061683-007	LABEL UPRIGHT	2
43	061683-010	LABEL UPRIGHT	2
44	061683-011	LABEL UPRIGHT (C-WEIGHT)	1
45	100342-000	LABEL SB60	4
46	100343-000	LABEL -BOOM-	2
47	100344-000	LABEL LIFT	2





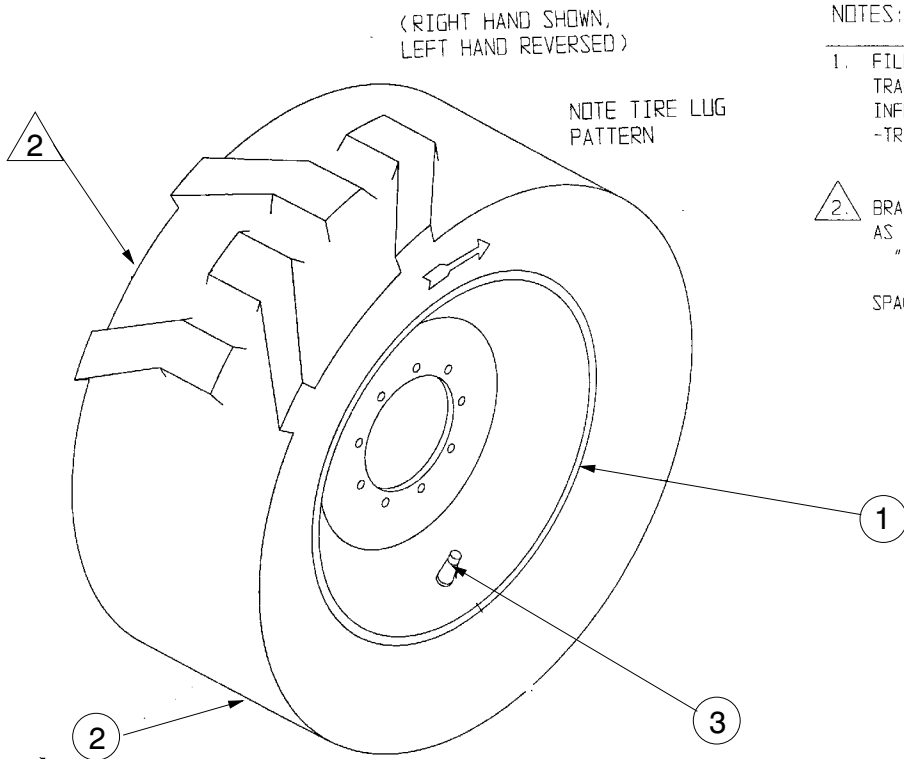
# Illustrated Parts Breakdown

## TIRE & WHEEL ASSEMBLY

100090-000 - LEFT HAND

100090-001 - RIGHT HAND

ITEM	PART	DESCRIPTION	QTY.
1	100091-000	WHEEL, 19.5 X 12 9 HOLE	1
2	100092-000	TIRE, 19.5 X 15 NHS 14 PLY	1
3	012282-001	VALVESTEM	1



NOTES:

1. FILL TIRE & WHEEL ASSY WITH 115-120 FL. OZ. OF TRAC SEAL (OR EQUIV) TIRE SEALANT. INFLATE TO 80 PSI MIN TIRE PRESSURE.  
-TRAC SEAL REQ. WT.= 12.5 - 13.5 LBS (REF)

2. BRAND BACKSIDE OF TIRE/WHEEL ASSY AS FOLLOWS:  
"UPRIGHT BKT"  
SPACE                      TIRE SEALANT  
LAST DIGIT OF YEAR WHEN TIRE WAS FILLED.      LETTER CORRESPONDING TO MONTH: (JAN=A ETC)

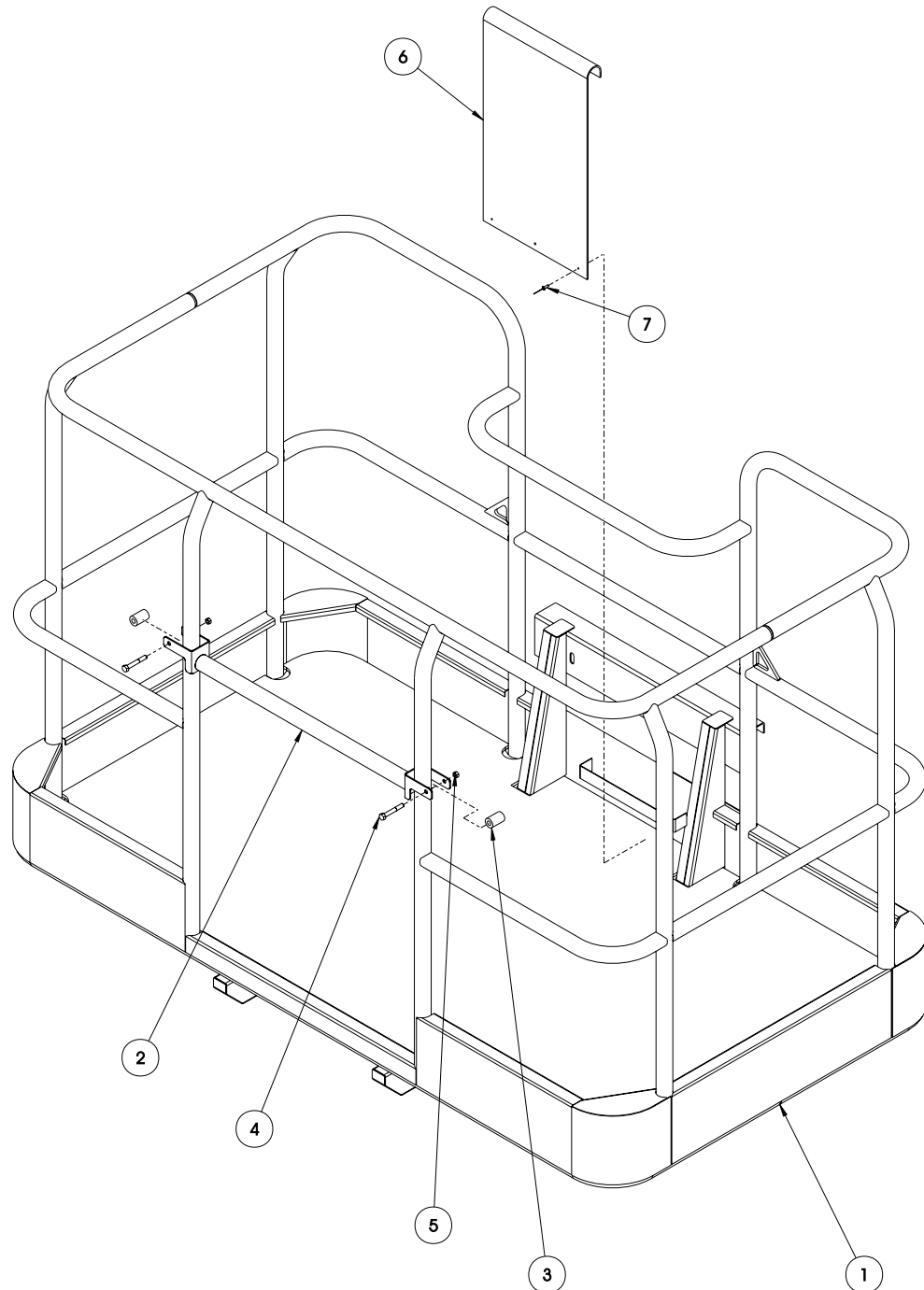
# Illustrated Parts Breakdown

Section  
**6.2**

## SIX FOOT CAGE ASSEMBLY

100417-000

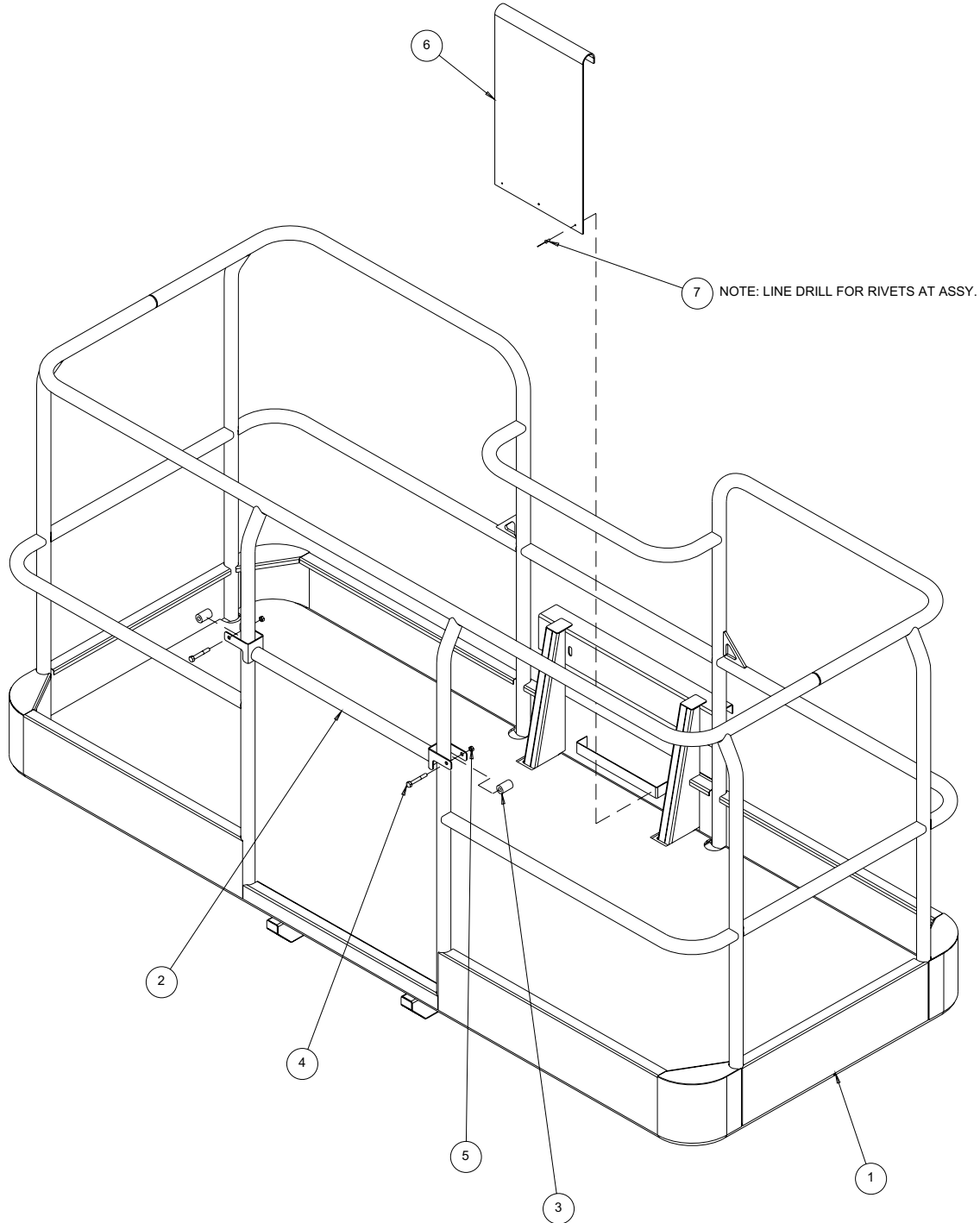
ITEM	PART	DESCRIPTION	QTY.
1	100450-001	CAGE WELDMENT	1
2	100478-000	LIFT-GATE WELDMENT	1
3	100481-000	ROLLER TUBE	2
4	11253-022	SCREW, HHC. 5/16-18 UNC X 2 3/4	2
5	11248-005	LOCKNUT, HEX. 5/16-18 UNC ESNA	2
6	100468-000	PANEL, DECAL MOUNT	1
7	26551-005	POP RIVET, 1/8" DIA. (3/16-1/4 GRIP)	3



## EIGHT FOOT CAGE OPTION

100417-001

ITEM	PART	DESCRIPTION	QTY.
1	100451-001	CAGE WELDMENT (8FT)	1
2	100478-000	LIFT-GATE WELDMENT	1
3	100481-000	ROLLERTUBE	2
4	011253-022	SCREW, HHC 5/16-18 UNC X 2-3/4	2
5	011248-005	LOCKNUT, HEX 5/16-18 UNC ESNA	2
6	100468-000	PANEL, DECAL MOUNT	1
7	026551-005	POP RIVET, 1/8" DIA. (3/1601/4 GRIP)	3



**NOTES:**

# Illustrated Parts Breakdown

## DUAL FUEL INSTALLATION OPTION SB60

100227-000

ITEM	PART	DESCRIPTION	QTY.
1	100228-000	DUAL FUEL KIT	1
2	(LP-24)	FITTING, TEE, 4MP-4FP-4FP	1
3	(LP-23)	FITTING, STRAIGHT, 4MP-6MJ	3
4	(LP-7)	FITTING, 90°, 4MP-4MJ	2
5	(LP-25)	HYDROSTATIC RELIEF VALVE	1
6	(LP57A)	HOSE ASSY, 3/8 X 84 LG (HIGH PRESSURE)	2
7	(LP-4)	SWIVEL JOINT 6FP-6MP	1
8	(LP-21)	FITTING, TEE, 4FP-4MP-4FP	1
9	(LP-30)	FITTING, 90° 4MP-1/8 BARB	1
10	(LP-33)	FITTING, 45°, 4MP-6MJ	2
11	(LP-45)	FITTING, 3/8 SCH80 NIPPLE X 3 LG	1
12	(LP-62)	FITTING, STRAIGHT, 6FP-6FP	1
13	(LP-8)	FITTING, 90°, 4MP-6MJ	1
14	(LP-57)	HOSE ASSY, 3/8 X 72 LG (HIGH PRESSURE)	1
15	(LP-37)	FITTING, STRAIGHT, 6MP-4FP	3
16	(LP-2)	FUEL SHUT OFF SOLENOID/FILTER	1
17	(LP-53A)	FITTING, STRAIGHT, 6MP-3/4 BARB	2
18	(LP-51A)	REGULATOR, NOLFF MODEL J	1
19	(LP-29)	FITTING, 90°, 6MP-6FP	2
20	(LP-61)	FITTING, 90°, 8MP - 5/8 HOSE BARB	1
21	(LP-55)	CLAMP, 5/8 HOSE	6
22	(LP-22)	FITTING, STRAIGHT, 8MP X 5/8 HOSE BARB	1
23	(LP-3)	LPG FUEL MIXER	1
24	(LP-56)	CLAMP, AIR CLEANER HOSES	2
25	(LP-16)	HOSE 5/8 ID X 72 LG	1
26	(LP-60)	HOSE 3/4 ID X 84 LG	1
27	(LP-20)	COUPLING, FUEL HOSE	2
28	(LP-12A)	HOSE, 1/8 VACUUM	FT 1.66
29	(LP-538)	FITTING, STRAIGHT, 8MP-3/4 BARB	1
32	029931-003	CONN. F PUSH	5
33	014914-003	CONN. M PUSH	1

ITEM	PART	DESCRIPTION	QTY.
34	029470-099	WIRE, 16 GA RED	FT 2
35	029496-099	CABLE, 2 COND/16 AWG "C-7"	FT 11
36	100445-099	HOSE, 2-1/2 ID EPDM (9 LG)	FT 2.2
37	068762-001	SOCKET CONTACT, 14-16 GA	2
38	029620-002	CONNECTOR, BUTT 14-16	2
39	015790-002	PIN CONTACT 16-18 GA	2
40	068698-001	TERMINAL BLOCK (TAN)	3
41	068698-002	TERMINAL BLOCK (BLUE)	1
42	029825-002	DIODE, 3 AMP	3
43	067661-001	RELAY, SPDT 12VDC	2
44	067662-001	RELAY SOCKET, SPDT	2
45	029610-006	CONNECTOR, FORK 16-14	10
46	029601-012	CONNECTOR, RING 16-14	4
47	002745-099	WIRE, 16 GA BLACK	FT 1
48	029352-099	WIRE, 16 GA RED/WHT	FT 2
49	029451-099	WIRE, 16 GA WHT	FT 2
50	029477-099	WIRE, 16 GA ORG/BLK	FT 2
51	029453-099	WIRE, 16 GA ORG	FT 2
52	029354-099	WIRE, 16 GA BLU/WHT	FT 3
53	067662-005	RETAINING CLIP ASSY	2
54	027934-003	FUEL TANK, PROPANE	2
55	068296-010	TANK MOUNTING KIT	2
56	011254-008	SCREW, 3/8-16 UNC HEX HD CAP X 1 LG	8
57	011240-006	WASHER, 3/8 FLAT	8
58	011248-006	LOCKNUT, 3/8-16 UNC HEX	8
59	064189-001	LABEL, LIQUID WITHDRAWL	2
60	064421-000	DECAL, SWITCH FUELS	1
61	011252-006	SCREW 1/4-20 UNC HHC X 3/4 LG	2
62	011238-004	WASHER 1/4 SPLIT LOCK	2
63	011240-004	WASHER 1/4 FLAT	2

\* Items 2-27 included in item 1 dual fuel kit 100228-000





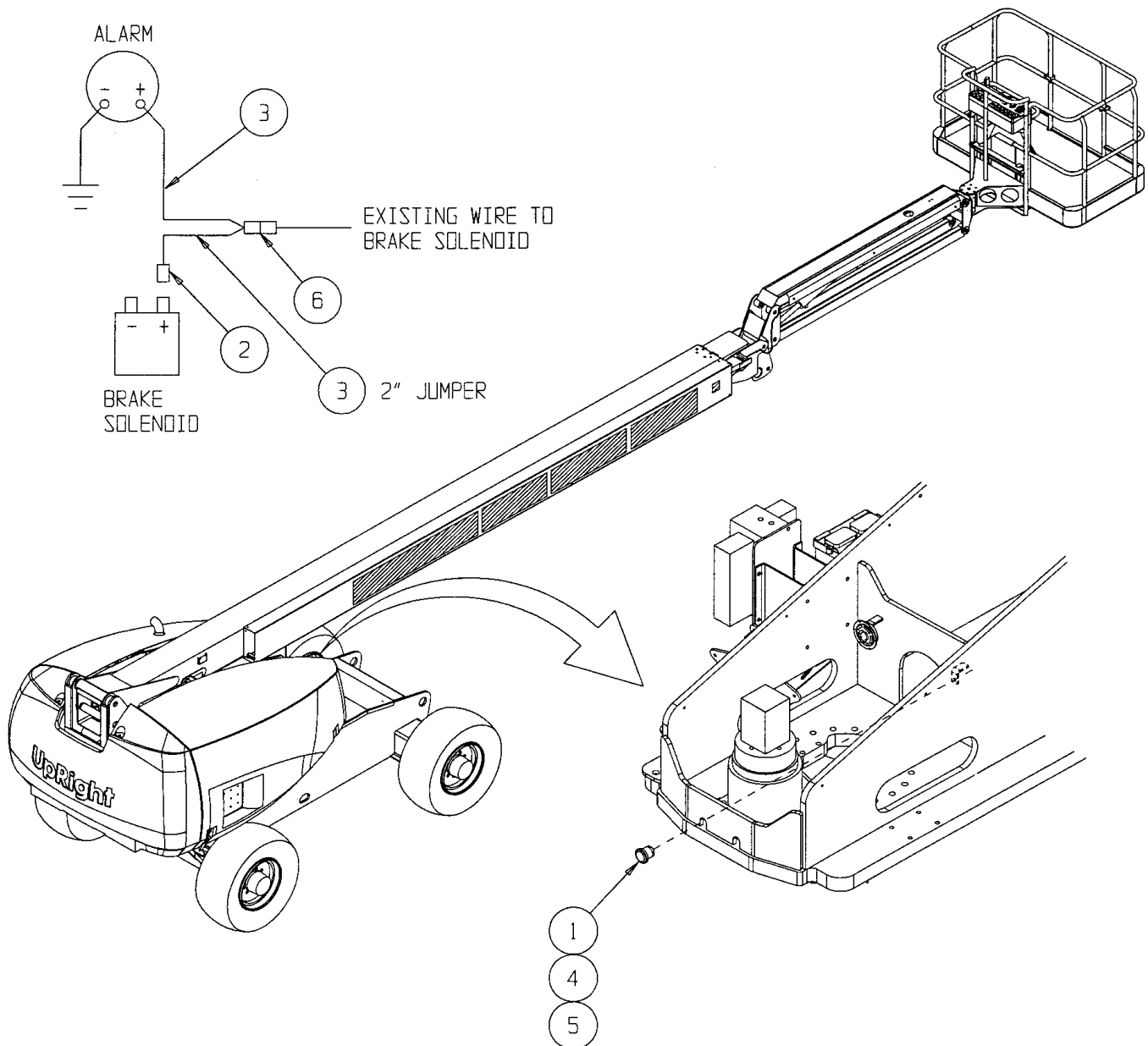


NOTES:

## MOTION ALARM OPTION

100096-000

ITEM	PART	DESCRIPTION	QTY.
1	066807-004	ALARM-112 DB	1
2	029616-002	CONN F PUSH 16-14 GA	1
3	029452-099	WIRE 16 GA BLK FT	6
4	011252-004	SCREW HHC 1/4-20 UNC X 1/2	1
5	011240-004	WASHER, FLAT 1/4	1
6	029617-002	CONN M PUSH 16-14 GA	1

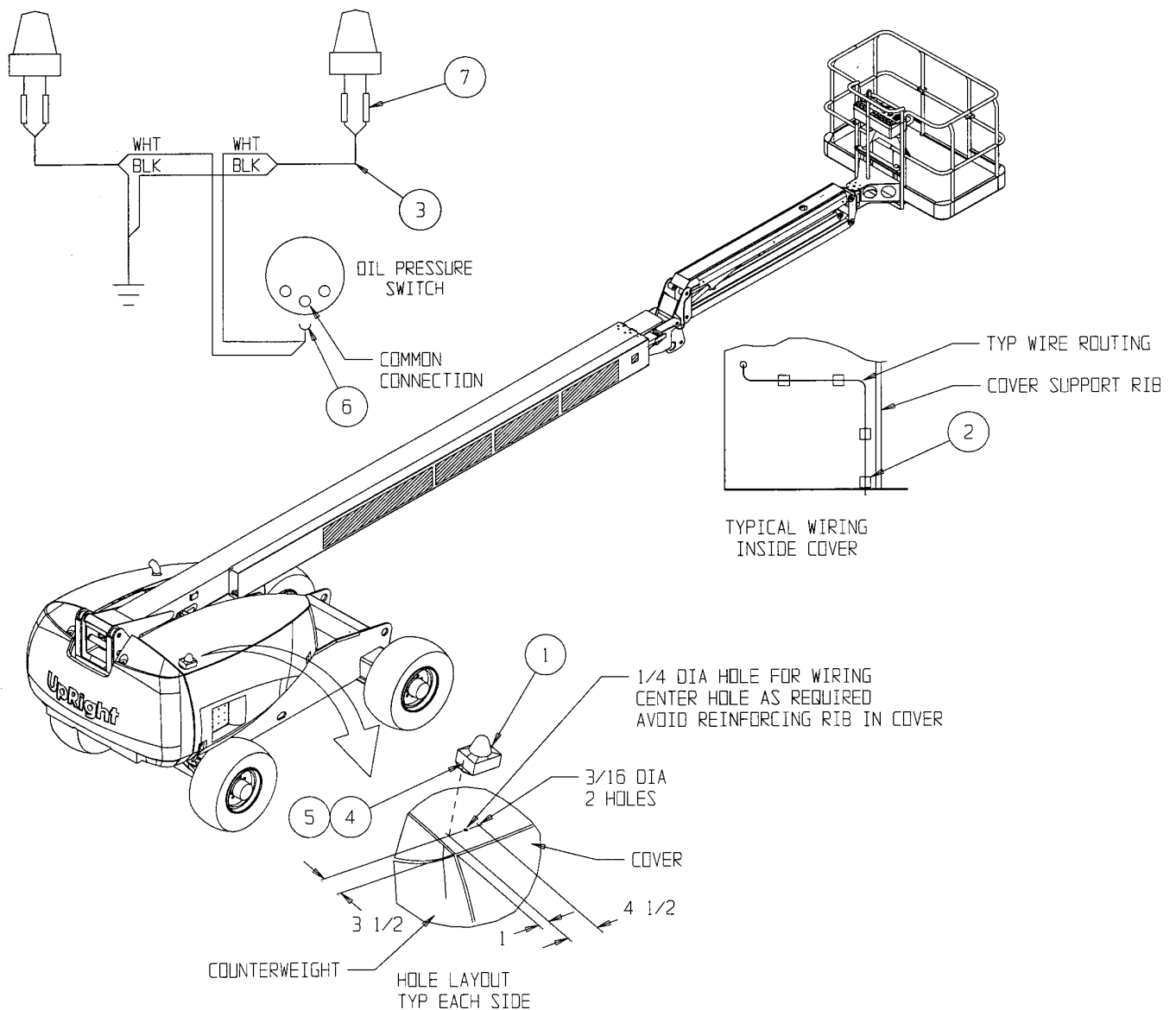


# Illustrated Parts Breakdown

## FLASHING BEACON OPTION

100097-000

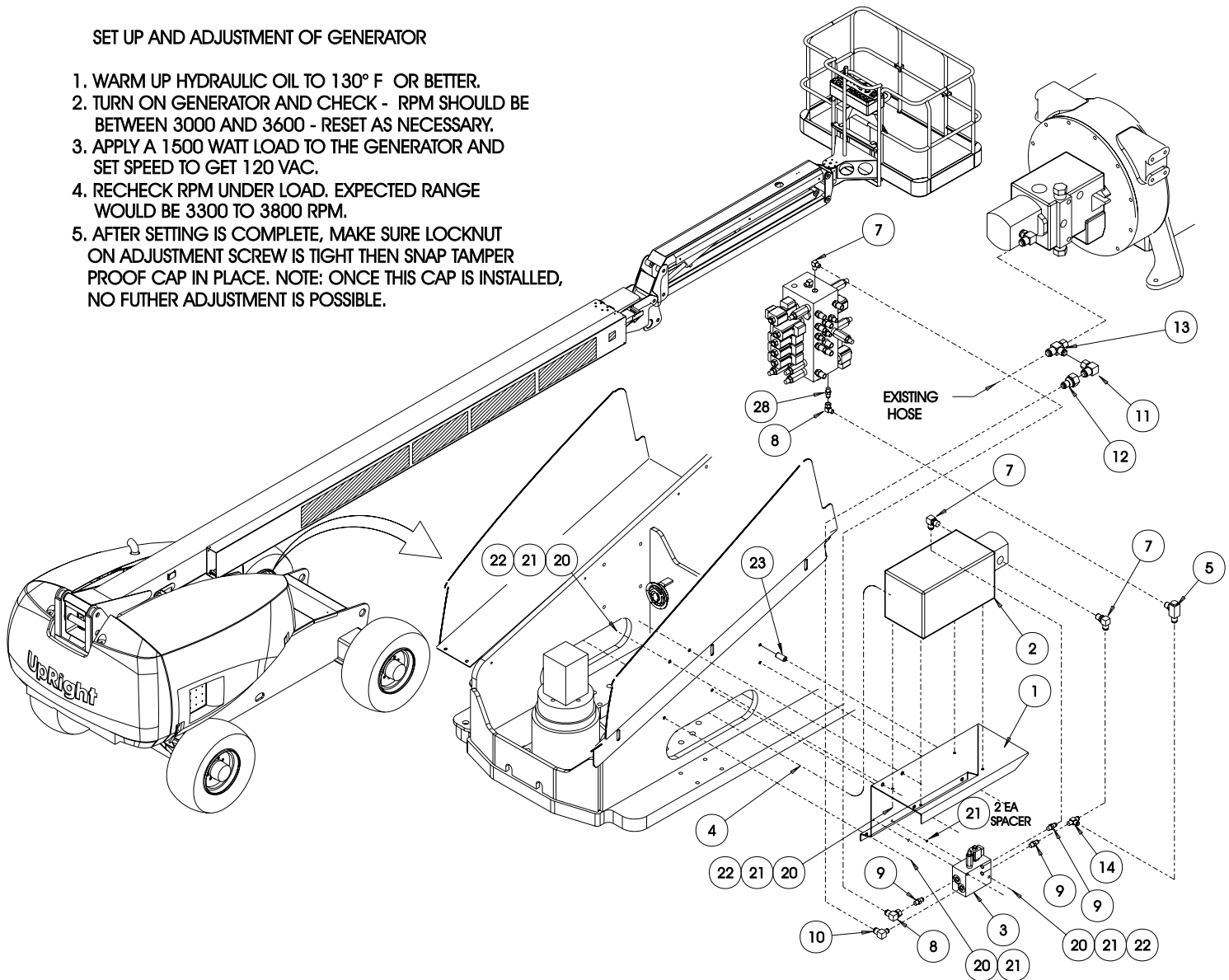
ITEM	PART	DESCRIPTION	QTY.
1	012848-004	FLASHING STROBELIGHT	2
2	013283-002	CABLE TYWRAP	8
3	029496-099	WIRE 2 COND 16 GA	FT 16
4	011709-008	SCREW #10-24 X UNC X 1 LG	4
5	011248-003	LOCKNUT #10-24 UNC ESNA	4
6	029610-002	CONN FORK 16-14 GA	1
7	029620-002	CONN BUTT 16-14 GA	4





## SET UP AND ADJUSTMENT OF GENERATOR

1. WARM UP HYDRAULIC OIL TO 130° F OR BETTER.
2. TURN ON GENERATOR AND CHECK - RPM SHOULD BE BETWEEN 3000 AND 3600 - RESET AS NECESSARY.
3. APPLY A 1500 WATT LOAD TO THE GENERATOR AND SET SPEED TO GET 120 VAC.
4. RECHECK RPM UNDER LOAD. EXPECTED RANGE WOULD BE 3300 TO 3800 RPM.
5. AFTER SETTING IS COMPLETE, MAKE SURE LOCKNUT ON ADJUSTMENT SCREW IS TIGHT THEN SNAP TAMPER PROOF CAP IN PLACE. NOTE: ONCE THIS CAP IS INSTALLED, NO FUTHER ADJUSTMENT IS POSSIBLE.



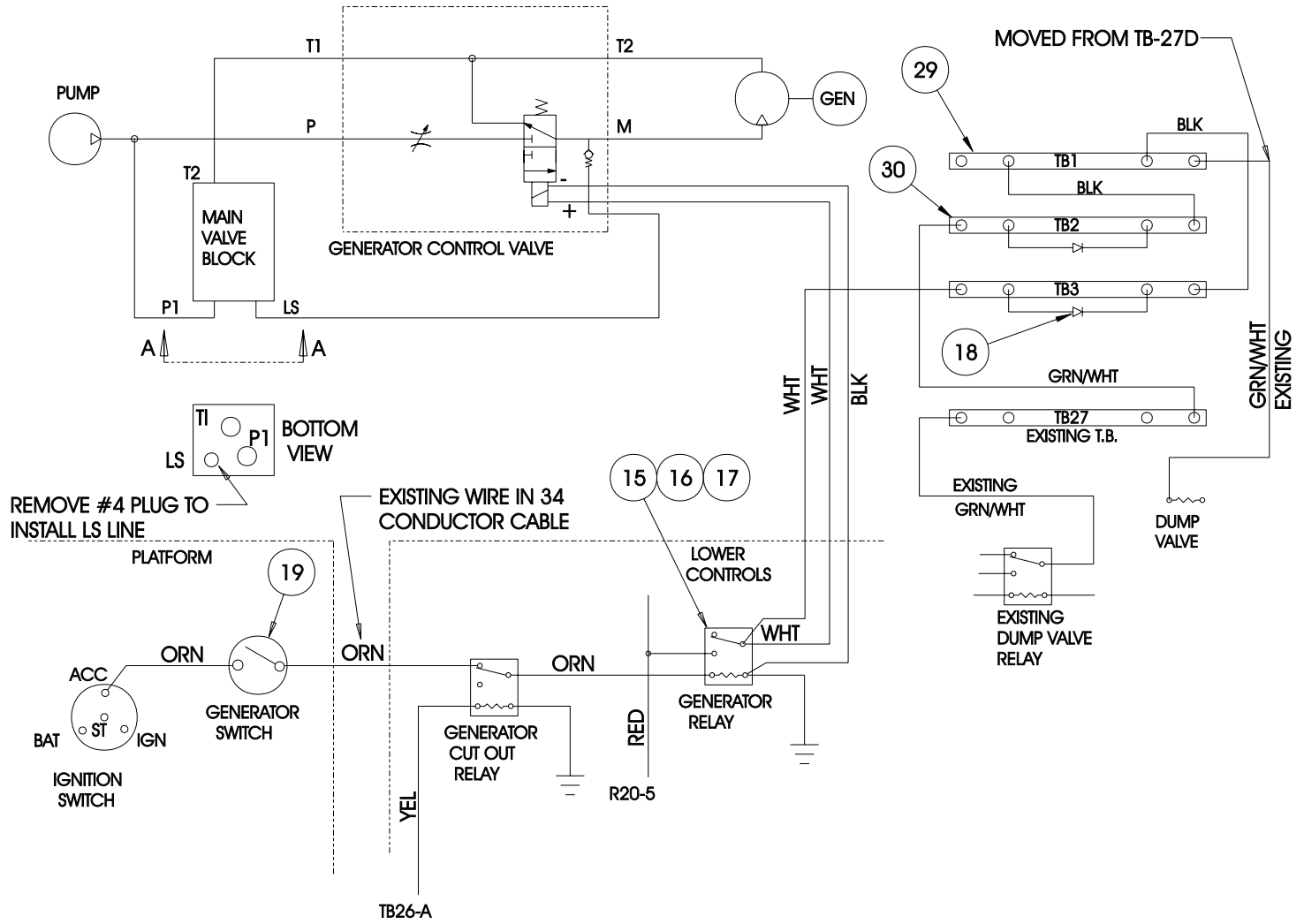
# Illustrated Parts Breakdown

## GENERATOR OPTION, DIESEL

100098-001

ITEM	PART	DESCRIPTION	QTY.
1	100699-000	WELDMENT, BRACKET	1
2	100702-000	GENERATOR ASSY	1
3	100704-000	VALVE BLOCK	1
4	100705-000	CORD ASSY	1
5	011931-003	FITTING, STR 6MB-6MJ LONG	1
6	100447-000	HOSE KIT	1
7	011934-007	FITTING O RING 90° 8MB-6MJ	3
8	011937-003	FITTING SWIVEL 90° 6FJX-6MJ	1
9	011941-005	FITTING STR 6MB-6MJ	2
10	011934-004	FITTING O RING 90° 6MB-6MJ	1
11	011937-004	FITTING SWIVEL 90° 8FJX-8MJ	1
12	014693-004	FITTING REDUCER 8MJ-6MJ	1
13	020733-003	FITTING TEE 8FJX-8MJ-8MJ	1
14	011937-001	FITTING, SWIVEL 90° 4FJX-4MJ	1
15	067661-001	RELAY SPDT 12V	2

ITEM	PART	DESCRIPTION	QTY.
16	067662-001	SOCKET	2
17	067662-005	RETAINER CLIP	2
18	029825-002	DIODE 3 AMP	2
19	012797-000	SWITCH TOGGLE	1
20	011254-008	SCREW HHC GR5 3/8-16 X 1	12
21	011238-006	WASHER 3/8	16
22	011250-006	NUT 3/8-16 UNC	8
23	018062-006	SPACER 1 5/8 OD X 2 LG	1
24	029451-099	WIRE WHT 16 GA	FT2
25	029456-099	WIRE YEL 16 GA	FT2
26	029454-099	WIRE RED 16 GA	FT2
27	029453-099	WIRE ORN 16 GA	FT3
28	011941-001	FITTING STR 4MB-4MJ	2
29	068698-001	TERMINAL BLOCK (TAN)	1
30	068698-002	TERMINAL BLOCK (BLUE)	2
31	029353-099	WIRE GRN/WHT 10 GA	FT2

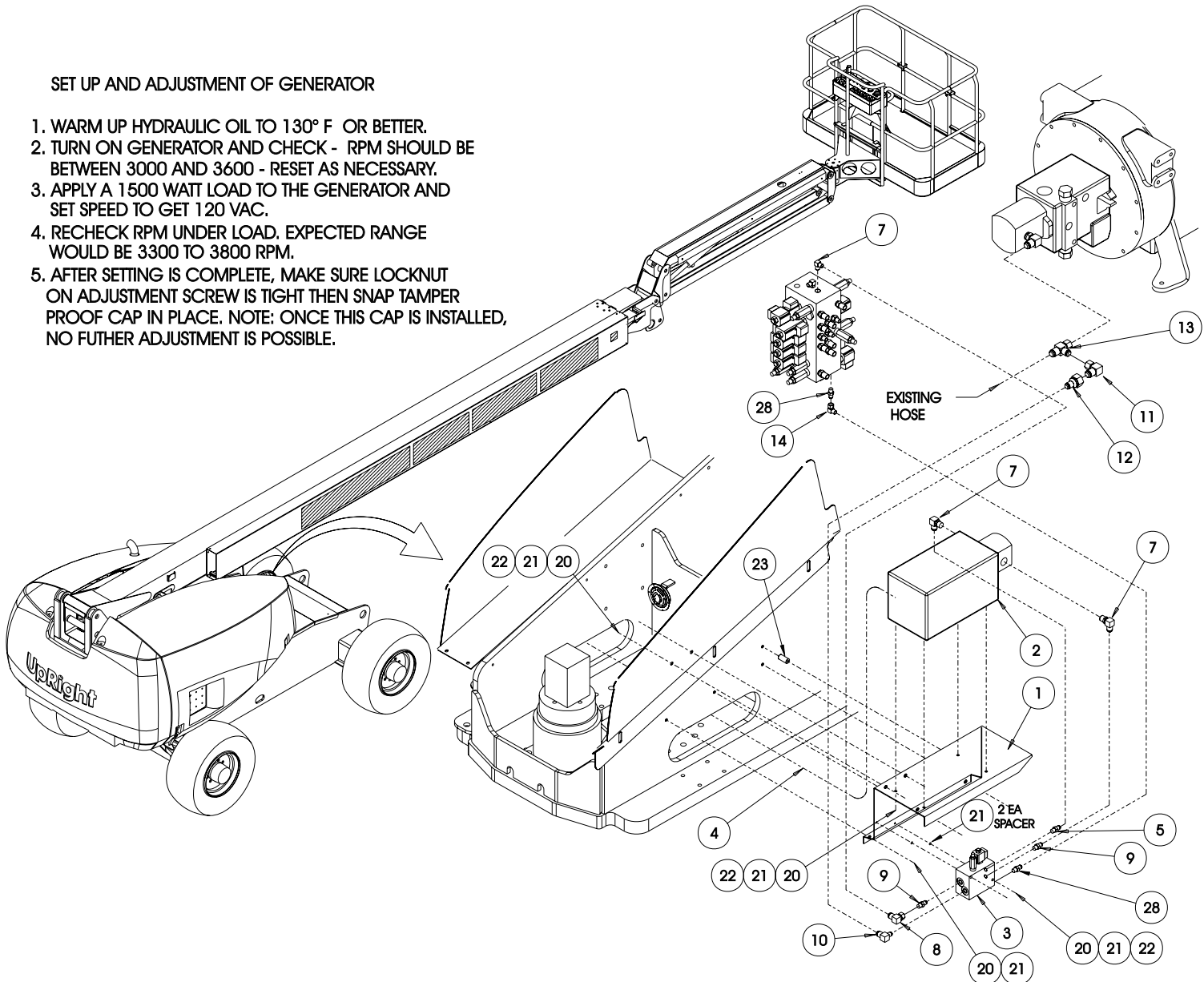


# Illustrated Parts Breakdown

Section  
6.2

## SET UP AND ADJUSTMENT OF GENERATOR

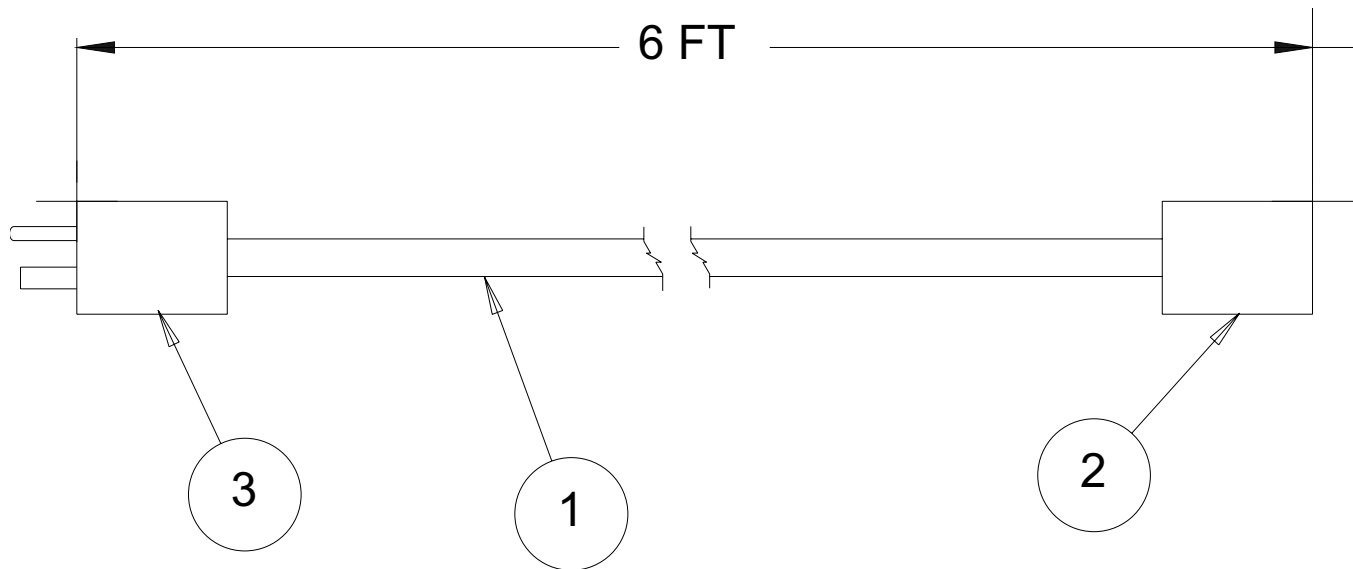
1. WARM UP HYDRAULIC OIL TO 130° F OR BETTER.
2. TURN ON GENERATOR AND CHECK - RPM SHOULD BE BETWEEN 3000 AND 3600 - RESET AS NECESSARY.
3. APPLY A 1500 WATT LOAD TO THE GENERATOR AND SET SPEED TO GET 120 VAC.
4. RECHECK RPM UNDER LOAD. EXPECTED RANGE WOULD BE 3300 TO 3800 RPM.
5. AFTER SETTING IS COMPLETE, MAKE SURE LOCKNUT ON ADJUSTMENT SCREW IS TIGHT THEN SNAP TAMPER PROOF CAP IN PLACE. NOTE: ONCE THIS CAP IS INSTALLED, NO FUTURE ADJUSTMENT IS POSSIBLE.



# Illustrated Parts Breakdown

**CORD ASSEMBLY -  
GENERATOR OPTION SB60**  
100705-000

ITEM	PART	DESCRIPTION	QTY.
1	100320-099	WIRE 3 COND. 12 GA	6
2	026614-000	PLUG, STRAIGHT FEMALE	1
3	026613-000	PLUG, STRAIGHT MALE	1



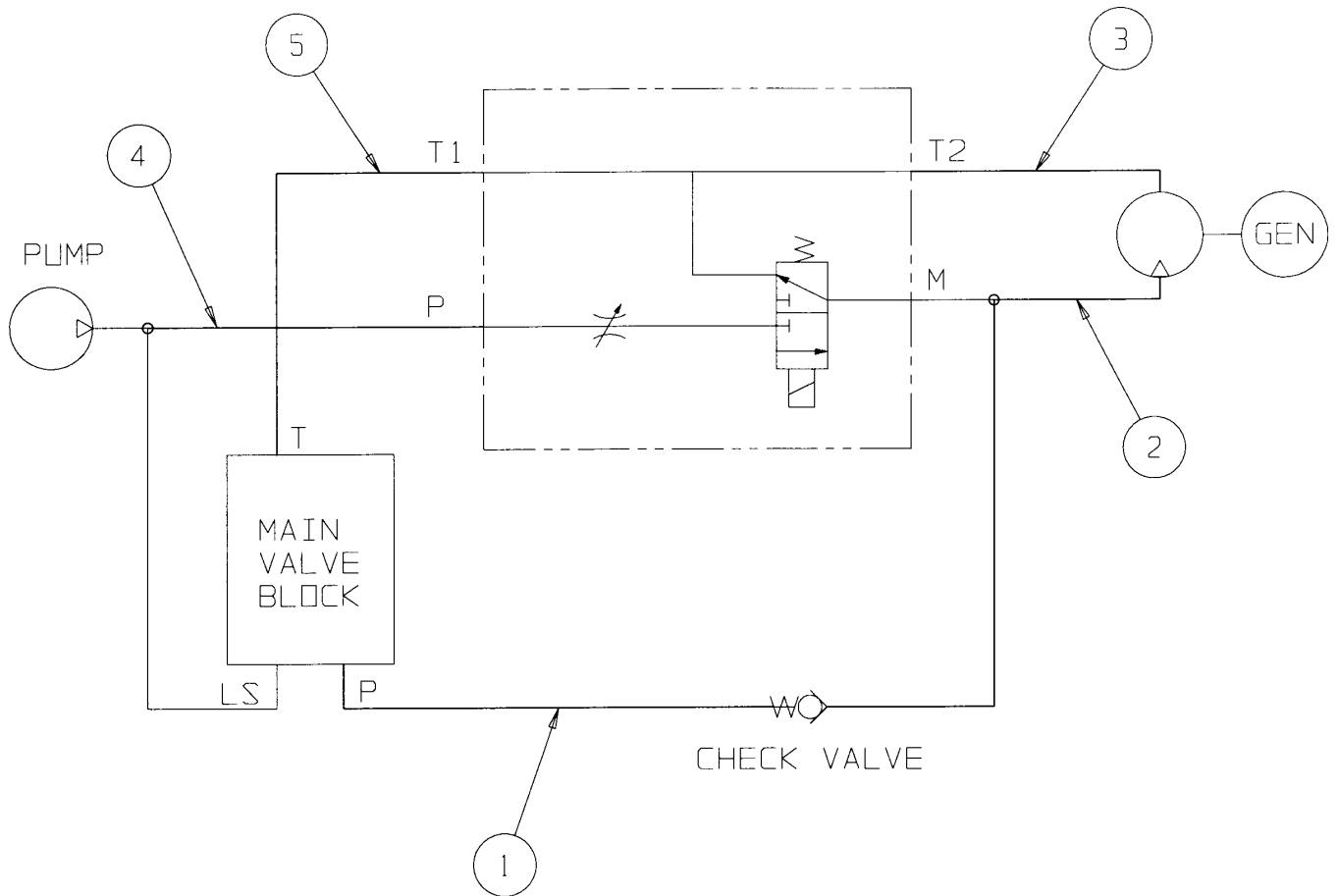


# Illustrated Parts Breakdown

## HOSE KIT - GENERATOR OPTION

100447-000

ITEM	PART	DESCRIPTION	QTY.
1	060861-001	ALARM - 112 DB	1
2	060861-049	CONN. F PUSH 16-14 GA	1
3	060861-063	WIRE 16 GA BLK	1
4	060861-074	SCREW HHC 1/4-20 UNC X 1/2	1
5	060861-076	WASHER, FLAT 1/4	1
6	060861-103	CONN. M PUSH 16-14 GA	1



NOTES:

# UpRight

Call Toll Free in U.S.A.

**1-800-926-LIFT**

**UpRight, Inc.**

1775 Park Street

Selma, California 93662

TEL: 209/891-5200

FAX: 209/896-9012

PARTS: 1-888-UR-PARTS

PARTSFAX: 209/896-9244

**100029-000**

9901 .1 K Rev-A