

UpRight

XL-C SERIES

SERVICE & PARTS MANUAL

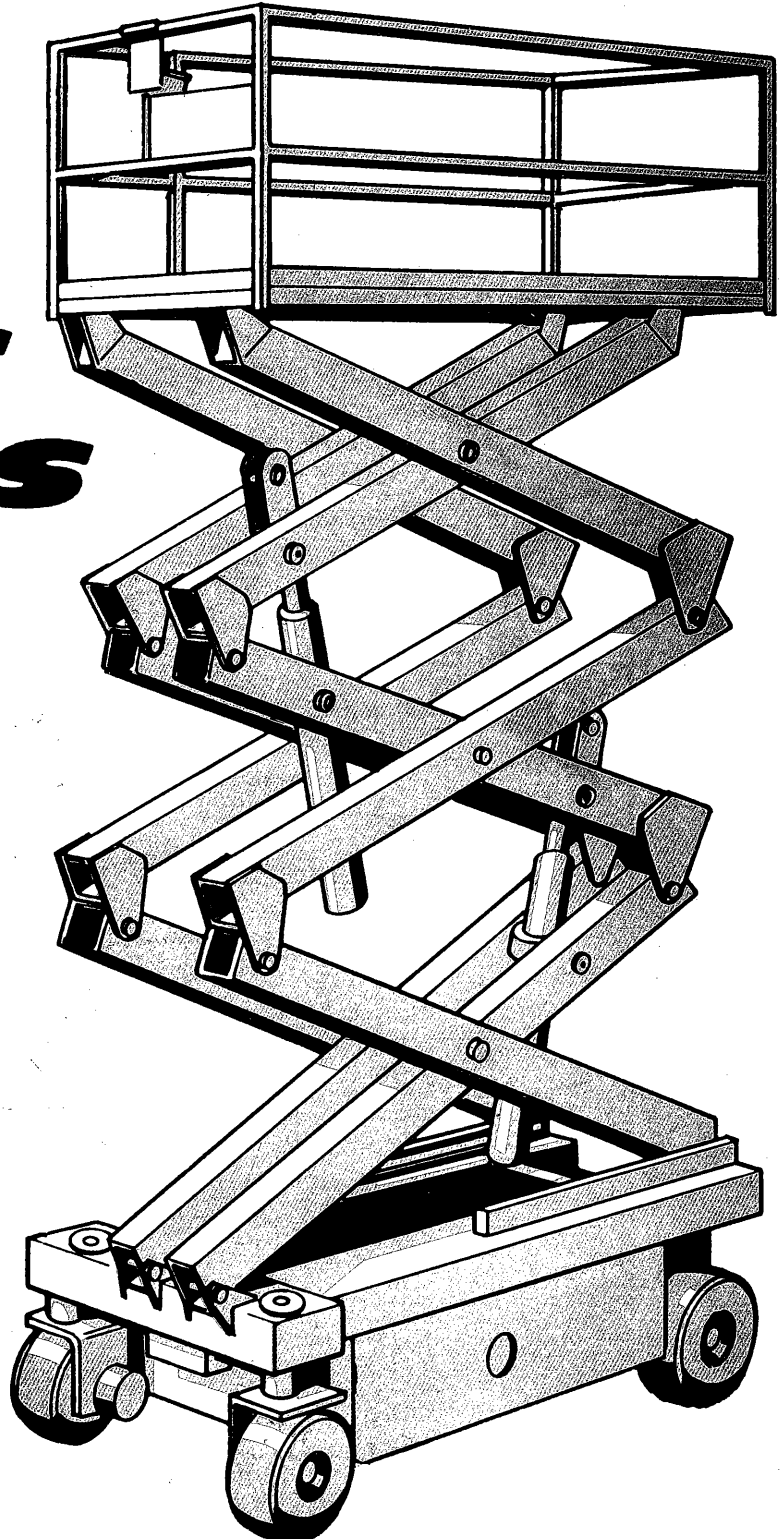

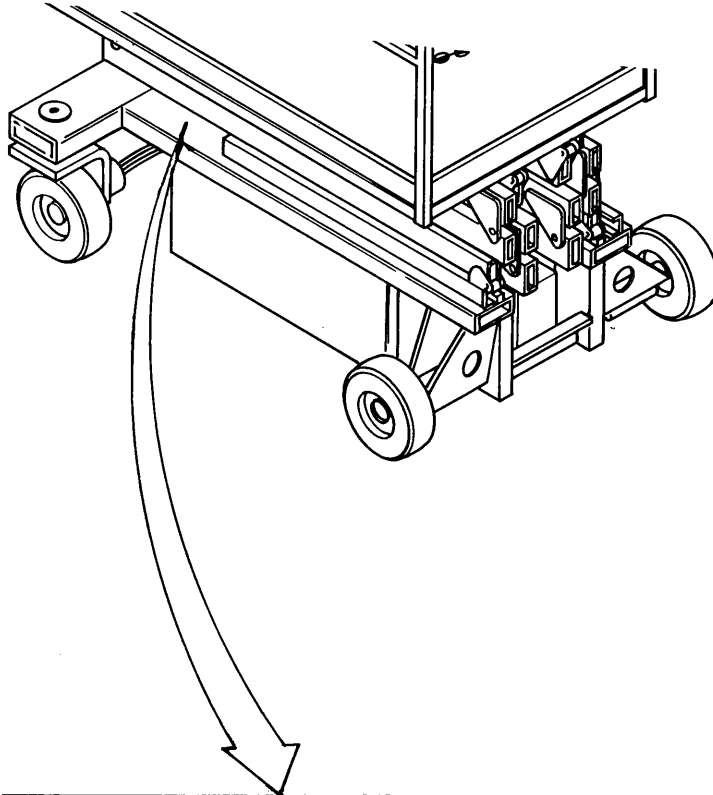

UP-RIGHT INC.	
1775 PARK ST. SELMA, CA 93662	
MODEL NO. <input type="text"/>	MAX. PLATFORM HEIGHT <input type="text"/>
SERIAL NO. <input type="text"/>	BATTERY VOLTAGE <input type="text"/>
MAX. DISTRIBUTED LOAD <input type="text"/>	<input type="text"/>
CAUTION: CONSULT OPERATOR'S MANUAL BEFORE USE.	
THIS PLATFORM IS NOT ELECTRICALLY INSULATED	
<small>P/N 61205-000-00</small>	

Part Number

Identification Plate and Model Number

SERVICE & PARTS MANUAL

Information herein, subject to change without notice. When contacting UpRight for service or parts information, be sure to include the MODEL and SERIAL NUMBERS from the equipment name plate.

UpRight

UpRight, Inc.
1775 Park Street
Selma, California 93662
TEL: 209/896-5150
FAX: 209/896-9012

Canada
108 Industrial Drive
Whitby, Ontario, Canada L1N5Z8
TEL: 416/668-7701

Call Toll Free
1-800-926-LIFT

February 1, 1991
Part No. 61799-001-00

TABLE OF CONTENTS

Section/Paragraph	Page
I. INTRODUCTION AND GENERAL INFORMATION	1-1
1-1. Introduction	1-1
1-2. Purpose	1-1
1-3. Scope	1-1
1-4. General Information	1-1
1-5. Item Description	1-1
1-6. Purpose and Limitations	1-1
1-7. Specifications	1-1
II. SAFETY RULES & OPERATIONS INSTRUCTIONS	2-1
2-1. Rules and Precautions	2-1
III. PREPARATION FOR USE, SHIPMENT AND STORAGE	3-1
3-1. Preparation for Use	3-1
3-2. Preparation for Shipment	3-1
3-3. Transport	3-1
3-4. Storage	3-1
IV. OPERATION INSTRUCTIONS	4-1
4-1. Theory of Operation	4-1
4-2. General Functioning	4-1
4-3. Driving	4-1
4-4. Raising and Lowering Platform	4-1
4-5. Safety Design	4-1
4-6. Controls and Indicators	4-1
4-7. Operating Procedures	4-1
4-8. Pre-Operation Checkout	4-1
4-9. Operation	4-3
4-10. Travel with Platform Lowered	4-3
4-11. Lifting Platform	4-3
4-12. Travel with Platform Elevated	4-3
4-13. XL-C Fold Down Guardrails	4-3
V. MAINTENANCE INSTRUCTIONS	5-1
5-1. Scope	5-1
5-2. Location of Components	5-1
5-3. Scheduled Inspection and Maintenance	5-1
5-4. General	5-1
5-5. Blocking Scissors	5-1
5-6. Maintenance-Detailed Instructions	5-3
5-7. Battery Maintenance	5-3
5-8. Lubrication	5-3
5-9. Hydraulic Oil Tank and Filter	5-4
5-10. Troubleshooting	5-4
5-11. Scope	5-4
5-12. Safety	5-4
5-13. General Procedure	5-4
5-14. Adjustments	5-7
5-15. Setting Hydraulic Pressure	5-7
5-16. Repair	5-7
5-17. Hydraulic Manifold	5-7
5-18. Hydraulic Pump	5-9
5-19. Hydraulic Drive Motors and Hubs	5-10
5-20. Wheel Bearings	5-10
5-21. Brake Cylinder	5-11
5-22. Steering Cylinder	5-12
5-23. Lift Cylinder Removal	5-12
5-24. Electric Motor	5-14
VI. DIAGRAMS	6-1
6-1. Content	6-1
6-2. Use	6-1
6-3. Index of Diagrams	6-1
6-4. Diagram Legends	6-1
VII. ILLUSTRATED PARTS BREAKDOWN	7-1
7-1. Introduction	7-1
VIII. OPTIONS	8-1
8-1. Introduction	8-1

LIST OF ILLUSTRATIONS

Figure	Title	Page
1-1.	Work Platform, XL-C Series	1-2
3-1.	Batteries	3-1
4-1.	Controls and Indicators	4-2
4-2.	Fold Down Guardrails	4-4
5-1.	Location of Components	5-1
5-2.	Location of Components, Chassis	5-1
5-3.	Blocking the Scissors	5-2
5-4.	Battery Charger	5-2
5-5.	Lubrication Points	5-3
5-6.	Hydraulic Oil Tank and Filter	5-4
5-7.	Hydraulic Pressure Adjustment	5-7
5-8.	Hydraulic Manifold	5-8
5-9.	Hydraulic Pump Removal	5-9
5-10.	Drive Motor Removal	5-10
5-11.	Wheel Bearings	5-10
5-12.	Brake Cylinder	5-11
5-13.	Steering Cylinder	5-12
5-14.	Lift Cylinder Removal	5-13
5-15.	Lift Cylinder Disassembly	5-14
5-16.	Electric Motor	5-15
6-1.	Electrical Diagram	6-2
6-2.	Hydraulic Diagram	6-4
7-1.	Work Platform, XL-19C	7-1
7-2.	Work Platform, XL-19CW, XL-24C & XL-24CW	7-2
7-3.	Chassis Assembly, XL-19C	7-3
7-4.	Chassis Assembly, XL-19CW, XL-24C & XL-24CW	7-4
7-5.	Front Steering and Hub Assembly, XL-19C	7-5
7-6.	Front Steering and Hub Assembly, XL-19CW, XL-24C & XL-24CW	7-6
7-7.	Drive Motor/Wheel Assembly, XL-C Series	7-7
7-8.	Module Assembly, XL-C Series	7-8
7-9.	Pump/Motor and Electrical Components Installation, XL-C Series	7-9
7-10.	Hydraulic Manifold Assembly, XL-C Series, Part I	7-10
	Hydraulic Manifold Assembly, XL-C Series, Part II	7-11
7-11.	Hydraulic Tank Installation, XL-C Series	7-12
7-12.	Rear Wheel and Hub Assembly, XL-19C	7-13
7-13.	Rear Wheel and Hub Assembly, XL-19CW, XL-24C & XL-24CW	7-14
7-14.	Hose Kit Installation, Chassis XL-19C	7-15
7-15.	Hose Kit Installation, Chassis XL-19CW, XL-24C & XL-24CW	7-16
7-16.	Scissors Assembly, XL-19C and XL-19CW	7-17
7-17.	Scissors Assembly, XL-24C and XL-24CW	7-18
7-18.	Lift Cylinder Installation, XL-C Series	7-19
7-19.	Fold Down Guardrail Installation, XL-19C	7-20
7-20.	Fold Down Guardrail Installation, XL-19CW, XL-24C and XL-24CW	7-21
7-21.	Controller Assembly, XL-C Series	7-22
7-22.	Decal Kit Installation, XL-C Series	7-23
8-1.	750 Lb. Capacity Option, XL-19C	8-1
8-2.	Battery Charger Indicator/Hourmeter Option, XL-C Series	8-2
8-3.	Flashing Amber Light Option, XL-C Series	8-3
8-4.	Horn and Reverse Alarm Option, XL-C Series	8-4
8-5.	Power to Platform Option, XL-C Series	8-5
8-6.	Air to Platform Option, XL-19C Series	8-6
8-7.	Removable Controller Option, XL-C Series	8-7
8-8.	Slideout Deck Option, XL-19C	8-8
8-9.	Slideout Deck Option, XL-19CW, XL-24C & XL-24CW	8-9
8-10.	Cantilever Cage Option Installation, XL-19C	8-10
8-11.	Cantilever Cage Option Installation, XL-19CW	8-11
8-12.	Cage Assembly, Cantilever Cage Option, XL-19C	8-12
8-13.	Cage Assembly, Cantilever Cage Option, XL-19CW & XL-24C	8-13
8-14.	Rolling Frame Assembly, Cantilever Cage Option, XL-19C	8-14
8-15.	Rolling Frame Assembly, Cantilever Cage Option, XL-19CW & XL-24C	8-15

LIST OF TABLES

Table	Title	Page
1-1.	Specifications	1-1
4-1.	Controls and Indicators	4-2
5-1.	Inspection, Checks and Services	5-2
5-2.	Troubleshooting	5-4
6-1.	Electrical Diagram Legend	6-1
6-2.	Hydraulic Diagram Legend	6-3

SECTION I

INTRODUCTION AND GENERAL INFORMATION

1-1 INTRODUCTION.

1-2 PURPOSE. This manual provides illustrations and instructions for the operation and maintenance of the UPRIGHT XL-C SERIES Work Platform manufactured by UpRight, Inc. Selma Operations, of Selma, California. (See Figure 1-1).

1-3 SCOPE. The operating instructions include both operation and maintenance responsibilities concerning the XL-C SERIES Work Platform's readiness. The functions cover scheduled maintenance, troubleshooting, repair, adjustment and replacement.

1-4 GENERAL INFORMATION.

1-5 ITEM DESCRIPTION. The UPRIGHT XL-C SERIES

Work Platform are self-propelled scissor lifts designed to be used as a means of elevating maintenance personnel and equipment and to provide a mobile work platform. They are redesigned to provide mobility with the platform in a raised or lowered position. Travel with the platform raised more than one foot is limited to the low speed range.

1-6 PURPOSE AND LIMITATIONS. The objective of the XL-C SERIES Work Platform is to provide a quickly deployable, self-propelled, variable height work platform. The elevating function shall only be used when the work platform is on a level paved or reinforced work area. The work platform is intended to be self-propelled when in relatively close proximity to the work area.

1-7 SPECIFICATIONS. Refer to Table 1-1.

Table 1-1. Specifications

ITEM	XL-19C / EUROPE	XL-19CW / EUROPE	XL-24C / XL-24CW
Platform Size	29" X 77" Inside Toeboards	48" X 89" Inside Toeboards	48" X 89" Inside Toeboards
Capacities			
Maximum Platform	550 Lbs. (750 Lbs. Opt.) / 550 Lbs.	1,000 Lbs.	750 Lbs.
Max. Cantiever Cage/Extension	250 Lbs.	250 Lbs.	250 Lbs.
Maximum Combined	Combined 550 Lbs.	Combined 1000 Lbs.	Combined 750 Lbs. / 1000 Lbs.
Height			
Working Height	25 Ft.	25 Ft.	30 Ft.
Max. Platform Height	19 Ft.	19 Ft.	24 Ft. (23' 11")
Min. Platform Height	44 In.	44 In.	50 In.
Dimensions			
Weight	2,650 Lbs.	2,600 Lbs.	3,195 Lbs. Approx. / 3,000 Lbs.
Overall Width	32-1/2 In.	50-3/4 In.	50-3/4 In.
Overall Height	86 In.	86 In.	91-1/2 In.
Overall Length	80 In.	82 In.	91 In.
Driveable Height	19 Ft. Standard 15 Ft. w/Cage Extension or 750 Load Rating	19 Ft. Standard	24 Ft. Standard
Surface Speed			
Platform Lowered	0 to 2 MPH	0 to 2 MPH	0 to 2 MPH
Platform Raised	0 to .7 MPH	0 to .7 MPH	0 to .7 MPH
Energy Source	24 Volt Battery Pack, 4 HP DC Electric Motor, Four 220 Ampere Hour Batteries	24 Volt Battery Pack, 4 HP DC Electric Motor, Four 220 Ampere Hour Batteries	24 Volt Battery Pack, 4 HP DC Electric Motor, Four 220 Ampere Hour Batteries
Battery Charger	25 AMP	25 AMP	25 AMP
Battery Duty Cycle	25% for 8 Hours	25% for 8 Hours	25% for 8 Hours
Hydraulic Tank Capacity	4 Gallons	4 Gallons	4 Gallons
Lift System	Two Single Stage Lift Cylinders	Two Single Stage Lift Cylinders	Three Single Stage Lift Cylinders
Drive Control	2 Speed, Forward and Reverse	2 Speed, Forward and Reverse	2 Speed, Forward and Reverse
Control System	Toggle Switches for All Functions	Toggle Switches for All Functions	Toggle Switches for All Functions / Mash-in Switch
Horizontal Drive	Dual Front Wheel	Dual Front Wheel	Dual Front Wheel
Tires	16 In. Diameter Solid Rubber	16 In. Diameter Solid Rubber (Option-16.5x6.5x8 Urethane Filled)	16 In. Diameter Solid Rubber (Option-16.5x6.5x8 Urethane Filled)
Braking	Spring Applied, Hydraulic Release Parking Brake	Spring Applied, Hydraulic Release Parking Brake	Spring Applied, Hydraulic Release Parking Brake
Turning Radius	24 In. Inside	24 In. Inside	24 In. Inside
Gradeability	25%	25%	25%
Wheel Base	62-1/2 In.	63 In.	63 In.
Guardrails	42 In High*	42 In High	42 In High
Toeboard	6 In. High	6 In. High	6 In. High

* Optional guardrails fold down to 79 In. for passage through 80 In. height door.
Specifications subject to change without notice.

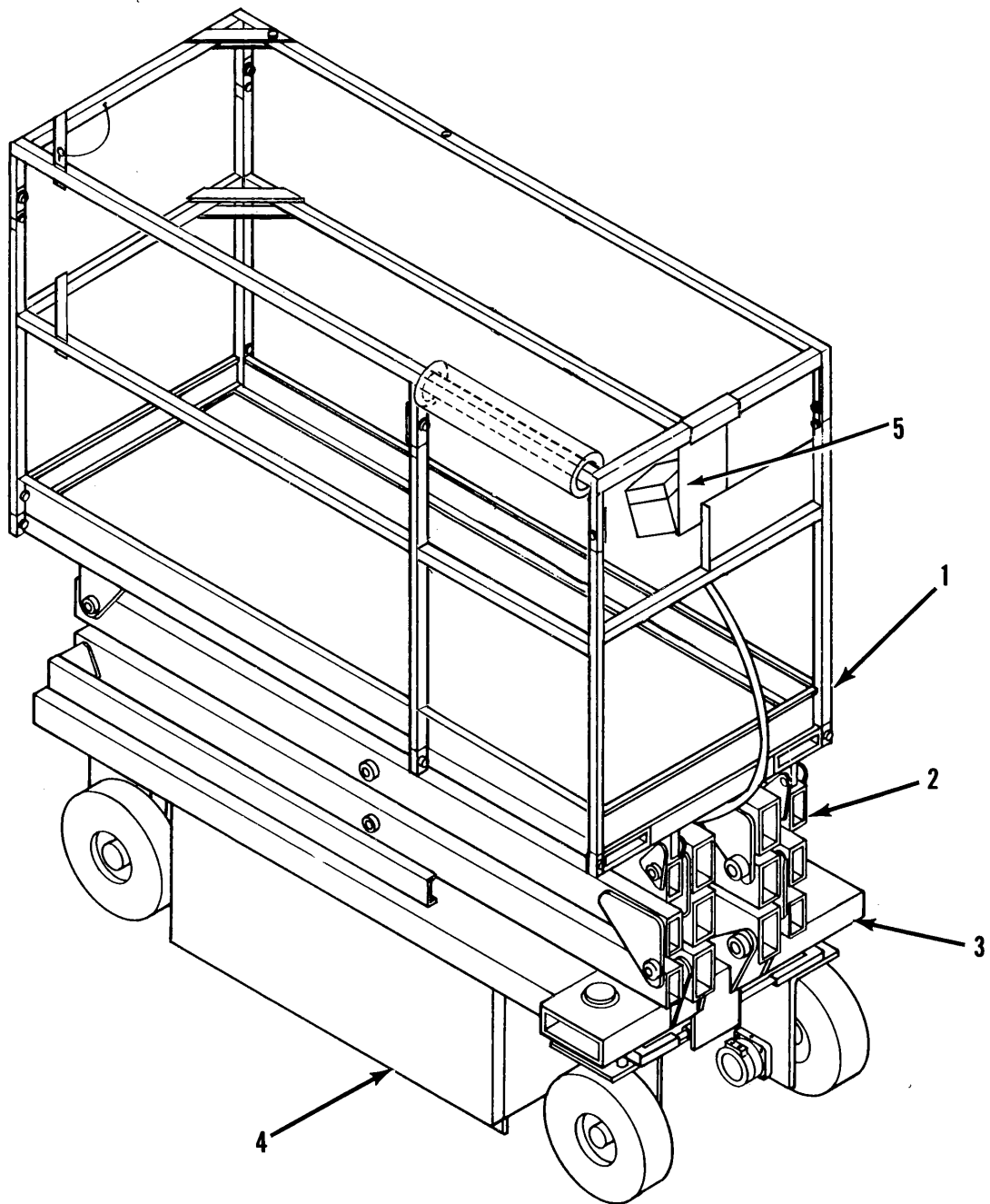

- 1. Platform
- 2. Scissor Mechanism
- 3. Chassis
- 4. Energy and Power Battery Terminal Module
- 5. Control Console

Figure 1-1. XL-C Work Platform

INSTRUCTION MANUAL

SECTION II

UpRight

XL-C SERIES

XL-19C SERIAL NO. 4208 TO CURRENT
XL-19CW SERIAL NO. 5197 TO CURRENT
XL-24 SERIAL NO. 8200 TO CURRENT

SAFETY RULES & OPERATING INSTRUCTIONS

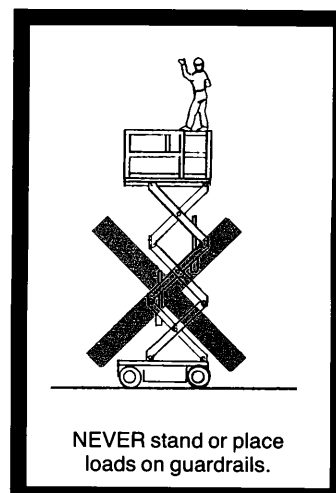
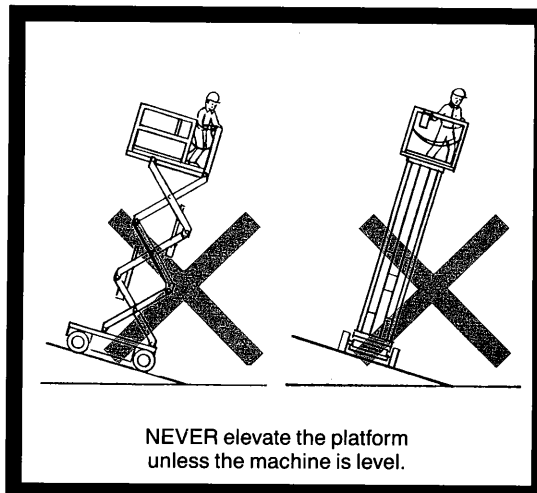
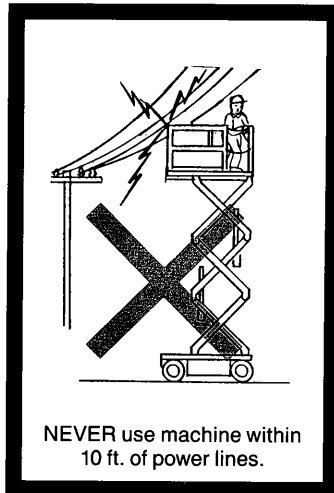

SAFETY RULES

BEFORE USING An Up-Right XL-C Series Work Platform:

- Thoroughly **INSPECT** the machine for cracked welds, loose hardware, hydraulic leaks, damaged control cable, loose wire connections and tire damage.
- **DISTRIBUTE** all loads evenly on the platform. See back cover for maximum platform load.
- **SURVEY** the work area for surface hazards such as holes, drop-offs, bumps and debris before operating machine.
- **LOOK** up, down and around for over head obstructions and electrical conductors.
- **LATCH** gate at entrance after mounting platform.
- **CHECK** that all guardrails are in place and secured with all fasteners in place.
- **NEVER** use damaged equipment. (Contact UP-RIGHT for instructions. See toll free numbers on back cover.)
- **NEVER** change operating or safety systems.
- **NEVER** operate the machine within ten feet of power lines. **THIS MACHINE IS NOT INSULATED.**
- **NEVER** elevate the platform or drive the machine while elevated unless the machine is on firm level surface.
- **NEVER** attach overhanging loads or increase platform size.
- **NEVER** use ladders or scaffolding on the platform.
- **NEVER** sit, stand or climb on guardrail or midrail.
- **NEVER** climb down scissors with the platform elevated.
- **NEVER** recharge batteries near sparks or open flame; batteries that are being charged emit highly explosive hydrogen gas.
- **NEVER** perform service on machine while platform is elevated without blocking the scissors.
- When transporting a gas power option, turn engine fuel valve to the off position. Keep gas power option level to prevent fuel spillage.
- **CHECK** that parking brake release valve is open for normal operation.

PRE-OPERATIONAL & SAFETY INSPECTION INSTRUCTIONS

**Read and fully understand all safety rules
and then follow these steps each day before use.**

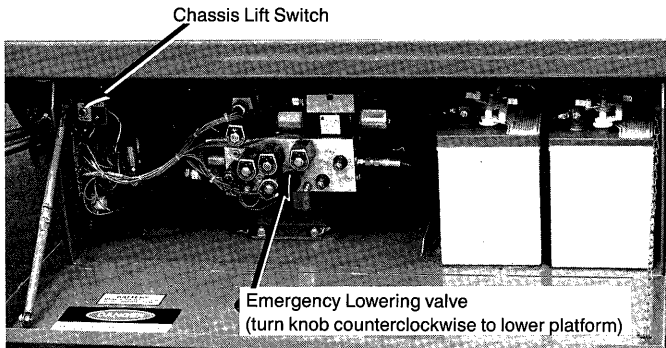

Figure 1. Power Module

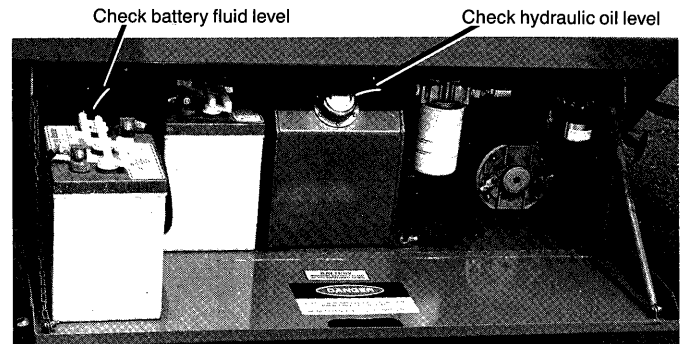

Figure 2. Energy Module

1. Visually inspect for any damage or missing parts.

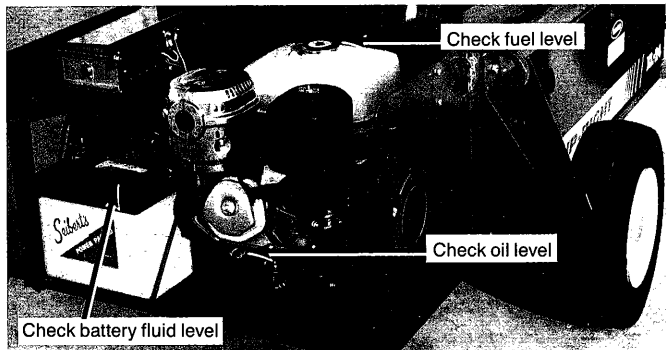

Figure 3. Optional Gas Energy Module

2. Open module covers.
3. Check hydraulic oil level with platform fully lowered. Oil should be visible in strainer (Figure 2). Use Mobile DTE 25 or equivalent.
4. Check battery fluid level (Figures 2 and 3).
5. Check state of battery charge (see Maintenance).
6. Check that AC extension cord has been disconnected from charger.
7. FOR GAS POWER OPTIONS: Check fuel level. Check oil level. Ensure all quick disconnect hoses are properly connected.

8. Check that emergency stop switch on control console is in "ON" position. When switch guard is closed, emergency stop switch will automatically go to "OFF" position.
9. Turn key switch to "DRIVE" position.
10. Depress foot switch. (Located on platform floor)
11. Push drive switch to "FORWARD" position then "REVERSE" position to check for speed and directional control.
12. Move steering switch right and then left to check steering control.
13. Move machine, if necessary, to unobstructed area to allow for full elevation.
14. Turn key switch to "LIFT" position.
15. Push chassis lift switch to "UP" position and fully elevate platform (Figure 1).

NOTE: Step 11 should be done with drive range selection in "LOW" and "HIGH"

— WARNING —
DO NOT ENTER SCISSORS LINKAGE AREA WHILE ELEVATED

16. While platform is elevated, visually inspect from outside of scissors linkage area scissors linkage, rollers, lift cylinder, cables and hoses for any damage or erratic operation.
17. Check for missing or loose parts and fasteners.
18. Lower platform partway by pushing chassis lift switch to "DOWN" (Figure 1).
19. Check for audible down alarm function while lowering.
20. Finish lowering platform by opening emergency lowering valve to check for proper valve operation (see "Emergency Lowering").
21. Close emergency lowering valve (Figure 1).
22. After all the preceding checks have been completed, close module covers.

STARTING THE XL-C SERIES EQUIPPED WITH THE GAS POWER OPTION:

1. Turn the fuel valve to the "ON" position.

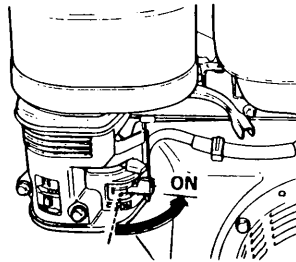

2. Move the choke lever to the "CLOSE" position.

NOTE: Do not use the choke if the engine is warm or the air temperature is high.

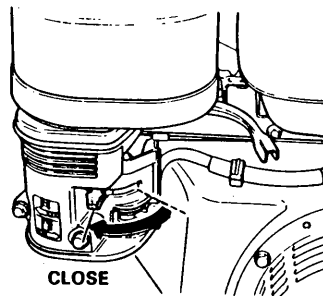

3. Move the throttle lever slightly to the left.

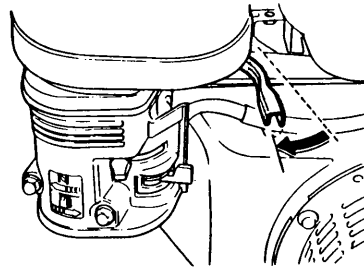

4. Start the engine.
 - With recoil starter: Turn the engine switch to the "ON" position.

NOTE: Do not use the electric starter for more than 5 seconds at a time. If the engine fails to start, release the switch and wait 10 seconds before operating the starter again.

When the engine starts, allow the engine switch return to the "ON" position.

STARTING ENGINE FROM THE CONTROLLER:

1. Turn fuel valve to the "ON" position. Check that emergency stop is in "ON" position. When switch guard is closed, emergency stop switch will automatically go to "OFF" position.
2. Turn mode selector switch (Figure 6) to "START". When engine starts, allow key to return to "ON" position.
3. Perform Pre-Operational and Safety inspection checks.

PREPARATION FOR USE

Ensure that pre-operation and safety inspection has been completed and any deficiencies have been corrected.

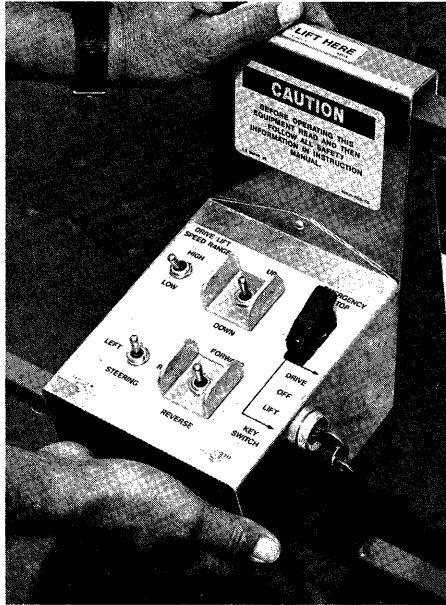

Figure 4.

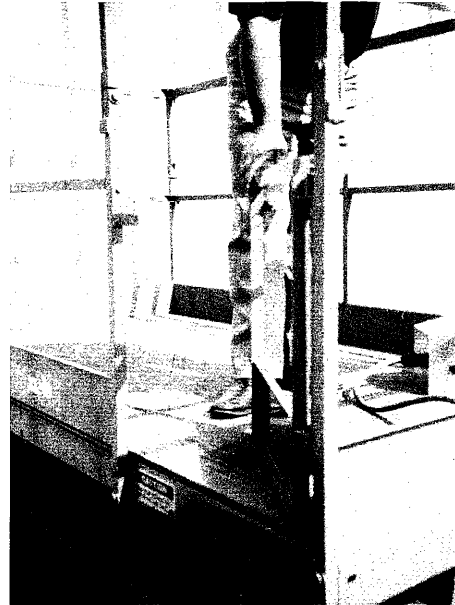

Figure 5.

1. Hang control console on guardrail (Figure 4).

2. After mounting platform, insure gate is closed and latched. Check that rear midrail is pinned into position.

OPERATING INSTRUCTIONS

Understand all functions of all controls before operating machine.

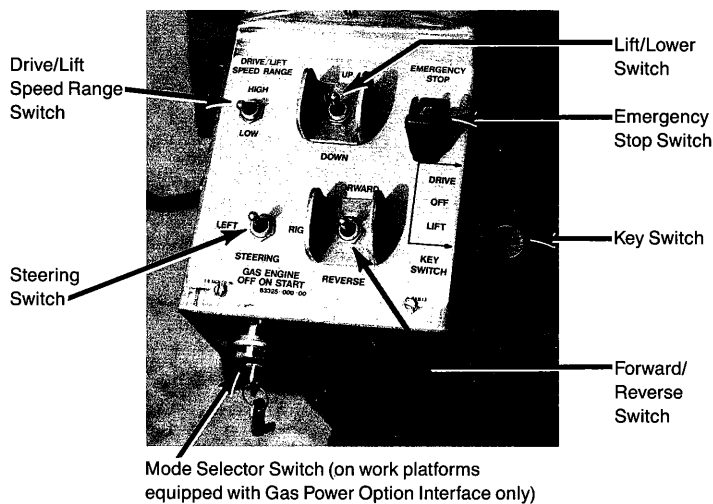

Figure 6. Control Console

— WARNING —
Before operating always check that route is clear of persons, obstructions, holes and dropoffs, above, below and to the sides of platform.

— WARNING —
Before traveling in reverse, double check that route is clear.

TRAVEL WITH PLATFORM LOWERED

NOTE: Always check that route is clear of obstructions, holes and drop-offs, and is capable of supporting the wheel loads.

1. Turn key switch to "DRIVE" position.
2. Set drive/lift speed range switch to "HIGH" for travel on level surfaces, to "LOW" for climbing grades and when traveling in confined areas.
3. Set the drive/lift speed range to "LOW".
4. Depress foot switch
5. Push drive switch "FORWARD" or "BACKWARD" to travel desired direction.
6. While moving, push drive/lift speed range switch to "HIGH" if faster speed is desired.

STEERING

1. Turn key switch to "DRIVE" position.
2. Depress foot switch.
3. Push steering switch right or left to turn wheels.

NOTE: Steering is not self-centering. Wheels must be returned to straight ahead position by operating switch.

ELEVATING PLATFORM

1. Turn key switch to "LIFT" position.
2. Set drive/lift speed range switch to "HIGH".
3. Depress foot switch.
4. Push lift/lower switch to "UP" position to elevate platform.

NOTE: Setting drive/lift speed range switch to "LOW" will allow slow elevation speed.

TRAVEL WITH PLATFORM ELEVATED

NOTE: Machine will travel at a reduced speed when platform is elevated.

1. Travel with platform elevated only on a hard level surface.
2. Turn key switch to "DRIVE" position.
3. Depress foot switch.
4. Push drive switch "FORWARD" or "BACKWARD" to change direction.

LOWERING PLATFORM

1. Turn key switch to "LIFT" position.
2. Depress foot switch.
3. Push lift/lower switch to "DOWN".

EMERGENCY LOWERING

— WARNING —

If platform should fail to lower, never climb down scissors. This could result in serious bodily injury.

1. Ask person on ground to open emergency lowering valve to lower platform. This valve is located on the left hand side of chassis through cut out in power module cover.
2. Open valve by turning knob counterclockwise (Figure 1).
3. Once platform is fully lowered, be certain that emergency lowering valve is closed again. The platform will not elevate if the emergency lowering valve has not been closed.

PARKING BRAKE RELEASE INFORMATION

1. Turn valve clockwise to close.
2. Activate push-pull thumb pump until brake is released.
3. Turn valve counterclockwise to fully open for normal brake function.

— WARNING —

Parking brake release valve to be closed for releasing parking brake only.

AFTER USE EACH DAY

1. Ensure that platform is fully lowered.
2. Park work platform on level ground, preferably under cover.
3. Secure against vandals, children or unauthorized operation.
4. Turn key switch to "OFF" position and remove key to prevent unauthorized operation.

XL-C SERIES FOLD DOWN GUARDRAILS

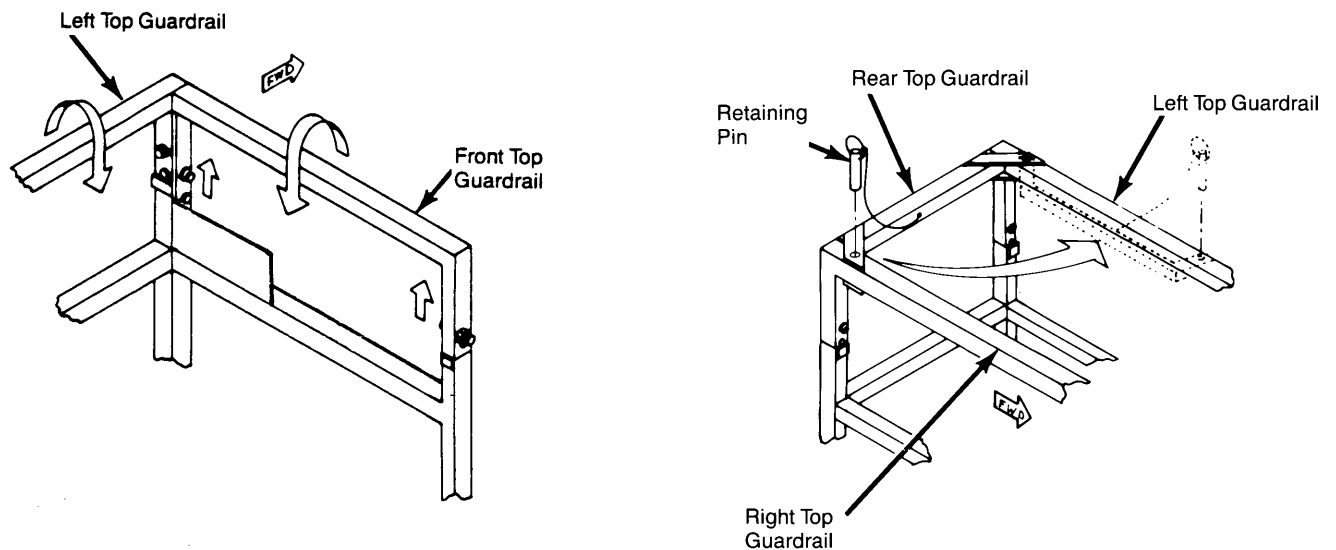

Figure 7.

XL-C SERIES GUARDRAIL FOLD DOWN PROCEDURE

1. Remove control console from front guardrail and lay it on the deck.
2. Lift up on top front guardrail until slots disengage from pins and then fold guardrail back.
3. Remove retaining pin at the right side of top rear guardrail, rotate it to position along left top guardrail and pin in place.
4. Lift up on on left top guardrail until slots disengage with pins and fold guardrail in.
5. Lift up on right top guardrail until slots disengage with pins and fold guardrail in.

XL-C SERIES GUARDRAIL ERECTION PROCEDURE

1. Raise the right top guardrail and then push down to engage pins with slots.
2. Raise the left top guardrail and then push down to engage pins with slots.
3. Remove retaining pin from rear top guardrail (attached to left top guardrail), swing it into place across rear of machine and pin to right top guardrail.
4. Raise front top guardrail and push down to engage pins with the slots.
5. Hook control console over front guardrail.

FORKLIFTING OF WORK PLATFORM

NOTE: Forklifting is for transporting only.

1. Forklift from rear end of work platform by using the frame sockets (Figures 8, 9 and 10).
2. Forklift from side by lifting under module.

NOTE: • See specifications for weight of work platform and be certain that forklift is of adequate capacity to lift work platform.

- Gas Power Option must be removed before work platform can be forklifted.

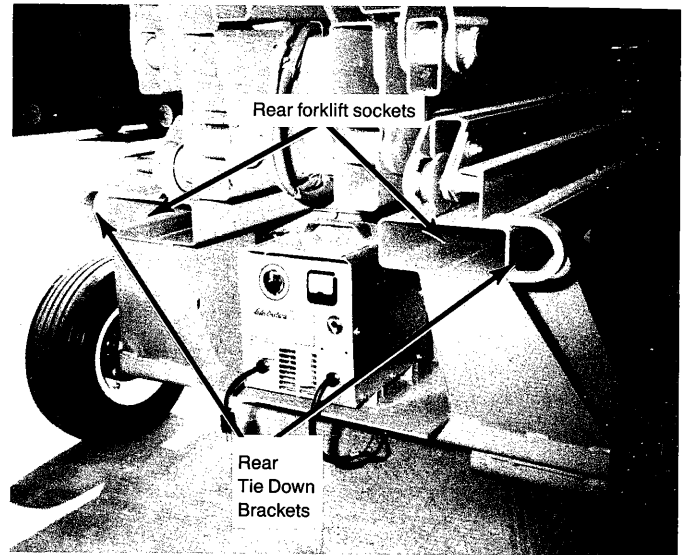

Figure 8. XL-19CW and XL-24C

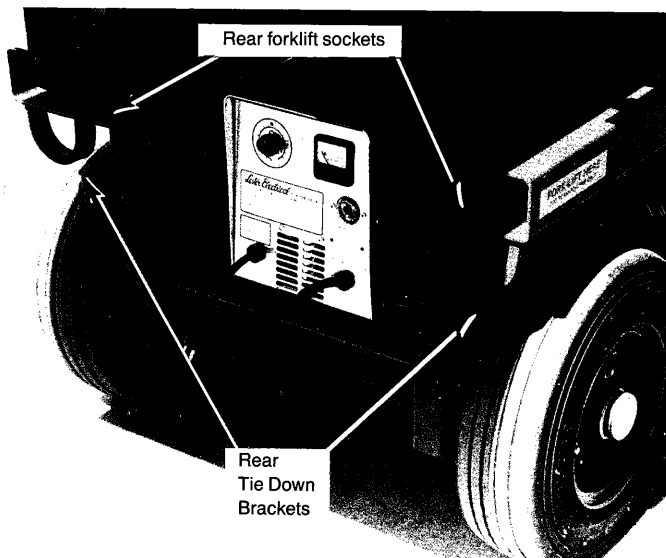

Figure 9. XL-19C

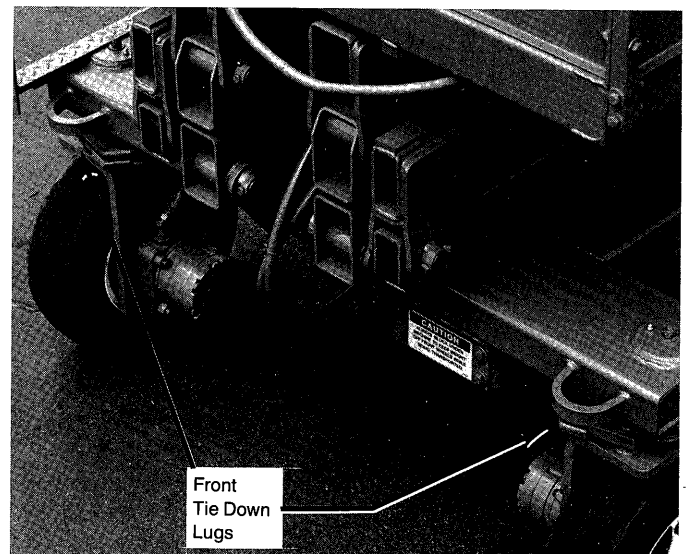

Figure 10. Front Tie Down Lugs

SECURING TO TRUCK FOR TRANSPORT

1. Always block under work platform to keep weight off front wheels while being transported.
2. Use tie down lugs to secure work platform for transport (Figures 6, 7 and 8).

— CAUTION —

Tie down lugs are not to be used for lifting work platform.

3. Use chains or straps of adequate load capacity.

— CAUTION —

Over-tightening may result in damage to work platform.

4. Always chock wheels on truck bed.

MAINTENANCE AND ROUTINE SERVICE

For proper service procedures see Service Manual.

— DANGER —
NEVER PERFORM SERVICE ON WORK PLATFORM WHILE PLATFORM IS ELEVATED WITHOUT FIRST BLOCKING THE SCISSORS (See detail "A", Figure 9).

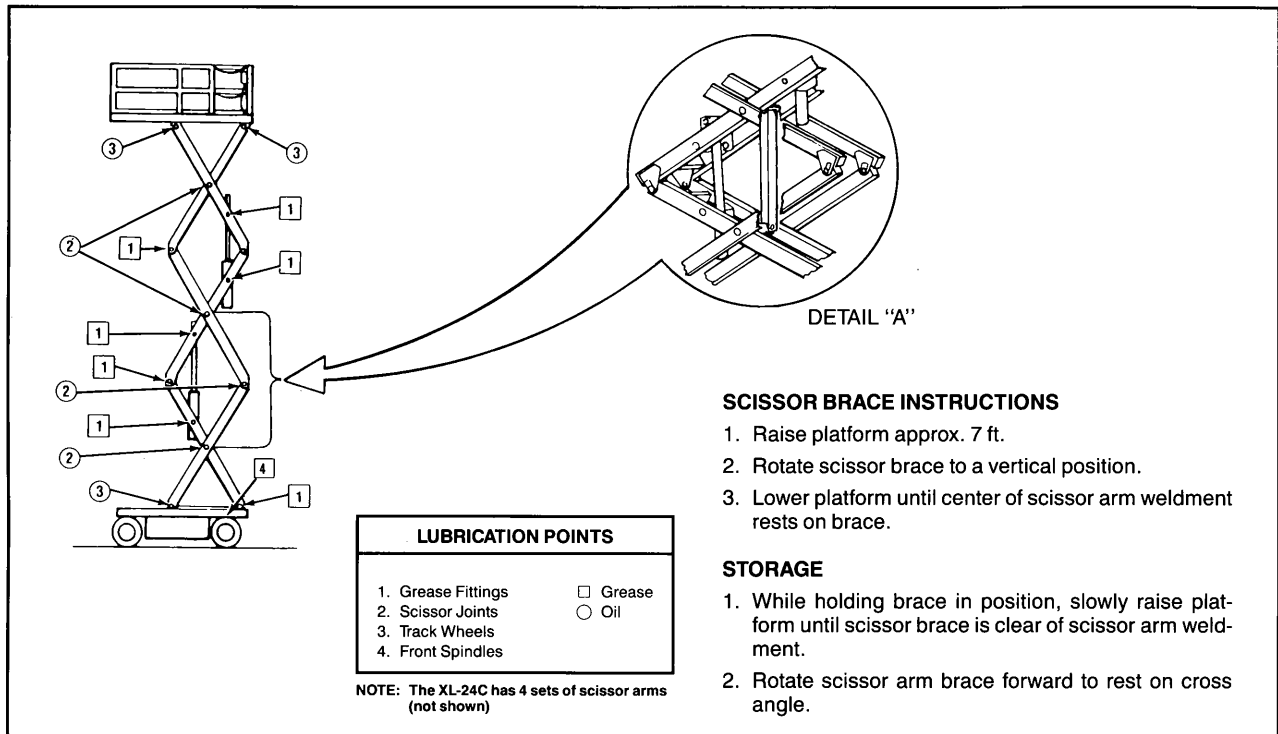

Figure 11. Blocking the scissors and lubrication points

MAINTENANCE AND ROUTINE SERVICE				
Service Operation	Service Interval			
	Daily	Monthly	Every 6 Mos.	Every 2 Yrs.
Check battery fluid level	x			
Charge batteries	x			
Check hydraulic fluid level	x			
Check lug nuts	x			
Grease and lubricate		x		
Change hydraulic filter			x	
Change hydraulic fluid				x
Check electric motor brushes			x	
FOR GAS POWER OPTION: Refer to Honda Instruction Manual for Engine Maintenance & Routine Service				

BATTERY MAINTENANCE

1. Check battery fluid level daily.
2. Charge batteries at end of each work shift or if they become discharged.
3. Keep tops of batteries clean.
4. For best battery life, follow instructions in XL-C Series service manual.

BATTERY CHARGING

1. Check battery fluid level.
2. Check battery charge indicator in power module to see state of charge in batteries.
3. The plug for the battery charger is located at the rear of the power module. Connect plug to properly grounded 115 volt, 60 HZ outlet.
4. Operation of the charger is automatic. The green light on side cover of charger is on when batteries are charging. The light will blink when batteries are fully charged.

— CAUTION —

Use charger only on battery systems specified on charger name plate. Connect only to properly grounded outlets. Disconnect only when supply cord is disconnected as arcing and burning may result. Surface of charger is very hot while charging and can cause burns. Avoid contact while charging. Keep charger dry.

GAS OPTION INSTALLATION

1. Using a suitable lifting device, slide the gas option module brackets into the chassis tubes and bolt into place with hardware provided.
2. Connect suction hose with quick disconnect.
3. Connect pressure hoses with quick disconnect.
4. Connect electrical to chassis connector.
5. Connect gas module battery.
6. Key switch on controller selects battery or gas engine operation. The switch also has a momentary engine start position. For electric battery operation, move switch to "OFF" position. For gas engine operation, turn key at engine to "ON", then move controller switch to "START" and release when engine starts.
7. Perform pre-operational checks as described on page 1 of this Users Manual.

NOTE: All batteries will charge when engine is in operation.

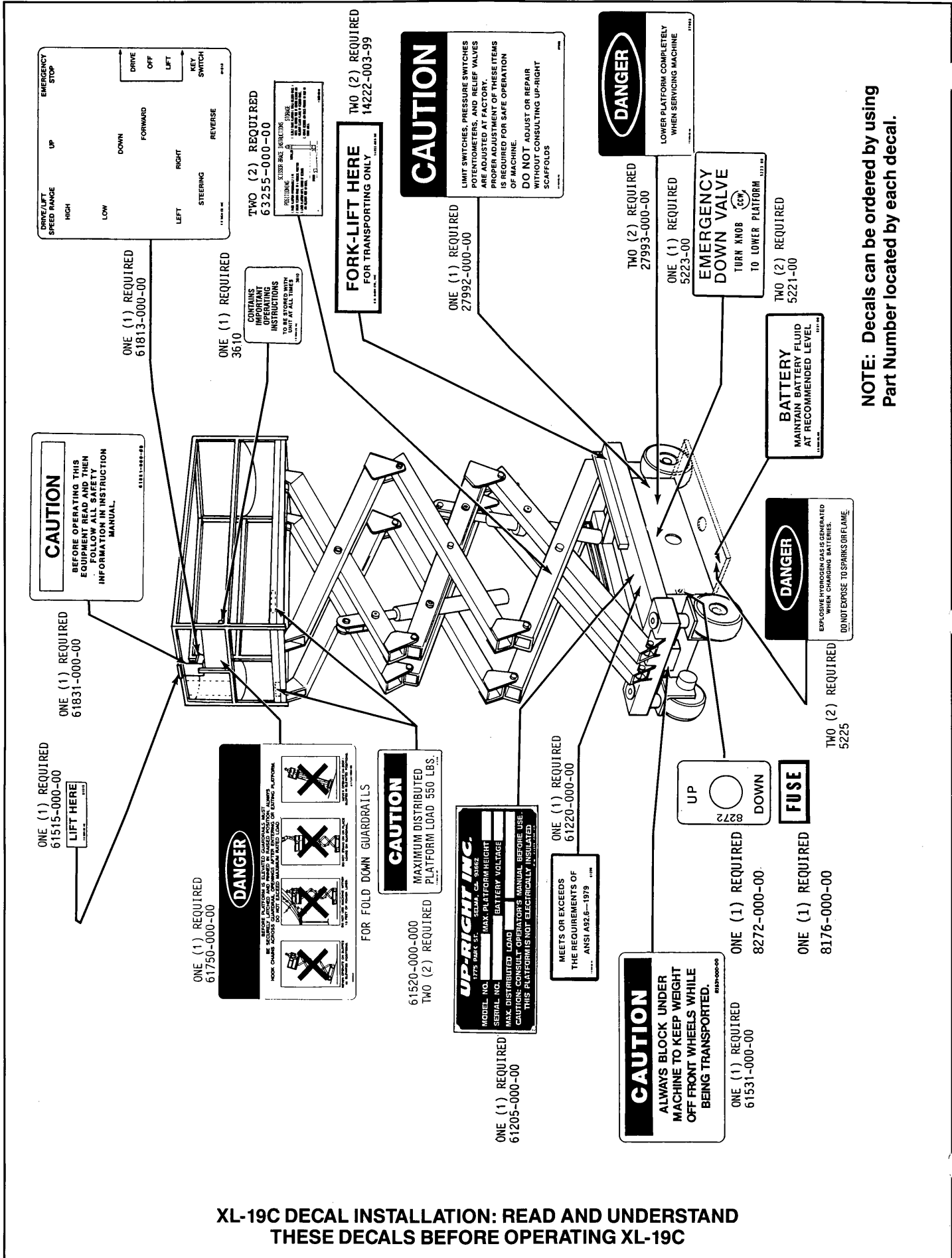

CAUTION
BEFORE OPERATING THIS EQUIPMENT READ AND THEN FOLLOW ALL SAFETY INFORMATION IN INSTRUCTION MANUAL.

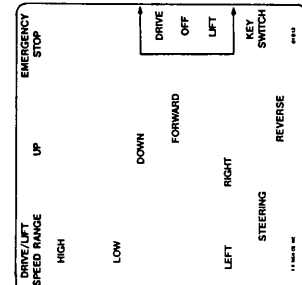

ONE (1) REQUIRED
61831-000-00

ONE (1) REQUIRED
61515-000-00
LIFT HERE

ONE (1) REQUIRED
61813-000-00

ONE (1) REQUIRED
3610

ONE (1) REQUIRED
61750-000-00

DANGER

BE SURE PLATFORM IS ALREADY TO MAINTAIN PROPER ANGLES WHEN CHANGING BATTERIES. DO NOT ATTEMPT TO MAINTAIN PROPER ANGLES WHILE CHANGING BATTERIES.

HOOK CHAINS ACROSS ALL FOUR CORNERS OF THE PLATFORM.

FOR FOLD DOWN GUARDRAILS

CAUTION
MAXIMUM DISTRIBUTED PLATFORM LOAD 950 LBS.

TWO (2) REQUIRED
61520-000-00

UP-RIGHTING

MODEL NO. 1775 PARK ST. SELMA, CA 95862

SERIAL NO. _____

MAX. PLATFORM HEIGHT _____

MAX. DISTRIBUTED LOAD _____

BATTERY VOLTAGE _____

CAUTIONS: CONSULT OPERATOR'S MANUAL BEFORE USE. THIS PLATFORM IS NOT ELECTRICALLY INSULATED.

ONE (1) REQUIRED
61205-000-00

ONE (1) REQUIRED
61220-000-00

CAUTION
ALWAYS BLOCK UNDER MACHINE TO KEEP WEIGHT OFF FRONT WHEELS WHILE BEING TRANSPORTED.

ONE (1) REQUIRED
61531-000-00

UP
8272
DOWN

ONE (1) REQUIRED
8272-000-00

FUSE

ONE (1) REQUIRED
8176-000-00

FORK-LIFT HERE
FOR TRANSPORTING ONLY

TWO (2) REQUIRED
14222-003-99

CAUTION

LIMIT SWITCHES, PRESSURE SWITCHES, POTENTIOMETERS, AND RELIEF VALVES ARE ADJUSTED AT FACTORY. PROPER ADJUSTMENT OF THESE ITEMS IS REQUIRED FOR SAFE OPERATION OF MACHINE. DO NOT ADJUST OR REPAIR WITHOUT CONSULTING UP-RIGHT SCAFFOLDS

ONE (1) REQUIRED
27992-000-00

DANGER

LOWER PLATFORM COMPLETELY WHEN SERVICING MACHINE

TWO (2) REQUIRED
27993-000-00

ONE (1) REQUIRED
5223-00

EMERGENCY DOWN VALVE
TURN KNOB TO LOWER PLATFORM

TWO (2) REQUIRED
5221-00

BATTERY
MAINTAIN BATTERY FLUID AT RECOMMENDED LEVEL

TWO (2) REQUIRED
5225

DANGER
EXPLOSIVE HYPERSPLASH IS GENERATED WHEN CHARGING BATTERIES. DO NOT EXPOSE TO SPARKS OR FLAME.

NOTE: Decals can be ordered by using Part Number located by each decal.

XL-19C DECAL INSTALLATION: READ AND UNDERSTAND THESE DECALS BEFORE OPERATING XL-19C

ONE (1) REQUIRED
61813-000-00

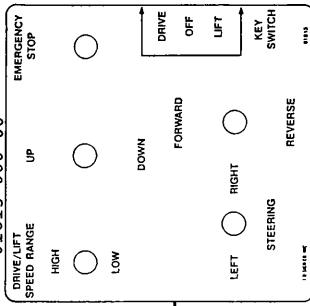

ONE (1) REQUIRED
60185-000-00

CAUTION
BEFORE OPERATING THIS EQUIPMENT, READ AND FOLLOW ALL SAFETY INFORMATION IN INSTRUCTION MANUAL. DO NOT PICK UP CONTROLLER BY THE DRIVE LEVER.

ONE (1) REQUIRED
61515-000-00

LIFT HERE

CONTAINS IMPORTANT OPERATING INSTRUCTIONS TO BE STORED WITH UNIT AT ALL TIMES

ONE (1) REQUIRED
03610-000-00

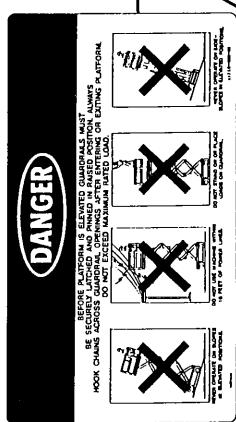

ONE (1) REQUIRED
61750-000-00

CAUTION
MAXIMUM DISTRIBUTED PLATFORM LOAD 1000 LBS. FOR XL-19CW & XL-24CW

CAUTION
MAXIMUM DISTRIBUTED PLATFORM LOAD 750 LBS. TWO (2) REQUIRED 08442-006-00 FOR XL-24C ONLY

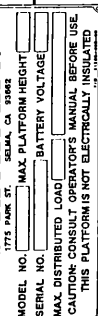

ONE (1) REQUIRED
61220-000-00

CAUTION
MEETS OR EXCEEDS THE REQUIREMENTS OF ANS1 A92.6-1979

TWO (2) REQUIRED
14222-003-99

FORK-LIFT HERE
FOR TRANSPORTING ONLY

DANGER
LOWER PLATFORM COMPLETELY WHEN SERVICING MACHINE

ONE (1) REQUIRED
27993-000-00

CAUTION
LIMIT SWITCHES, PRESSURE SWITCHES, RELIEF VALVES AND RELIEF VALVES ARE ADJUSTED. PROPER ADJUSTMENT OF THESE ITEMS IS REQUIRED FOR SAFE OPERATION OF MACHINE. DO NOT ADJUST OR REPAIR WITHOUT CONSULTING UP-RIGHT SCAFFOLDS

ONE (1) REQUIRED
27992-000-00

ONE (1) REQUIRED
05223-000-00

EMERGENCY DOWN VALVE
TURN KNOB TO LOWER PLATFORM

BATTERY
MAINTAIN BATTERY FLUID AT RECOMMENDED LEVEL

TWO (2) REQUIRED
05221-000-00

DANGER
EXPLOSIVE HYDROGEN GAS IS GENERATED WHEN CHARGING BATTERIES. DO NOT EXPOSE TO SPARKS OR FLAME.

TWO (2) REQUIRED
05225-000-00

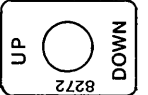

ONE (1) REQUIRED
8272-000-00

FUSE

ONE (1) REQUIRED
8176-000-00

CAUTION
ALWAYS BLOCK UNDER MACHINE TO KEEP WEIGHT OFF FRONT WHEELS WHILE BEING TRANSPORTED.

ONE (1) REQUIRED
61531-000-00

NOTE: Decals can be ordered by using Part Number located by each decal. For machines equipped with fold down extension or cantilever cage, consult Service Manual.

XL-19CW AND XL-24C DECAL INSTALLATION: READ AND UNDERSTAND THESE DECALS BEFORE OPERATING THESE PLATFORMS

SPECIFICATIONS *

AMERICAN STANDARD				METRIC			
Item	XL-19C	XL-19CW	XL-24C/XL24W	XL-19C	XL-19CW	XL-24C/XL-24W	
Platform Size	29" x 77" Inside Toeboards	48 x 89" Inside Toeboards	48" x 89" Inside Toeboards	0.74 x 1.96 M.	1.22 x 2.26 M.	1.22 x 2.26 M.	
Maximum Platform Capacity Max Cantilever/ Extension	550 Lbs. (750 Lbs. Opt.)	1,000 Lbs.	750 Lbs./1000 Lbs.	250 Kg.	450 Kg.	340 Kg./455 Kg	
	250 Lbs.	250 Lbs.	250 Lbs.	110 Kg.	110 Kg.	110 Kg.	
Max Combined Capacity	Combined 550 Lbs.	Combined 1000 Lbs.	Combined 750 Lbs.	250 Kg.	450 Kg.	340 Kg.	
Height Working Height Max. Platform Ht. Min. Platform Ht.	25 Ft. 19 Ft. 44 In.	25 Ft. 19 Ft. 44 In.	30 Ft. 24 Ft. (23'11") 50 In.	7.62 M. 5.79 M. 1.12 M.	7.62 M. 5.79 M. 1.12 M.	9.12 M. 7.29 M. 1.27 M.	
	Dimensions Weight Weight w/Gas Power Option Overall Width Overall Height Overall Length Overall Length w/Gas Power Option	2,650 Lbs. 2865 Lbs. 32.5 In. 86 In. 80 In. 98 1/4 In.	2,600 Lbs. 2815 Lbs. 50 3/4 In. 86 In. 82 In. 109 1/4 In.	3,195 Lbs. Approx. 3410 Lbs. 50 3/4 In. / 56 7/8 In. 91 1/2 In. 91 In. / 92 In. 109 1/4 In. / 110 1/4 In.	1202 Kg. 1299 Kg. 0.83 M. 2.18 M. 2.03 M. 2.50 M.	1179 Kg. 1277 Kg. 1.29 M. 2.18 M. 2.08 M. 2.77 M.	1449 Kg. 1546 Kg. 1.29 M. / 1.44 M. 2.32 M. 2.31 M. / 2.34 M. 2.77 M. / 2.80 M.
	Driveable Height	19 Ft. Standard 15 Ft. w/Cage, deck or 750 lb. capacity	19 Ft. Standard	24 Ft. Standard	5.79 M. Standard 4.57 M. w/Cage, deck or 340 Kg. Rating	5.79 M. Standard	7.29 M. Standard
Surface Speed Platform Lowered Platform Raised	0 to 2 MPH 0 to .7 MPH	0 to 2 MPH 0 to .7 MPH	0 to 2 MPH 0 to .7 MPH	0.89 M/S 1.1 M/S	0.89 M/S 1.1 M/S	0.89 M/S KMS/hr.	
	Energy Source Electric Gas Power Option	24 Volt Battery Pack 4 HP DC Electric Motor Four 220 Ampere Hour Batteries 11 HP Gas Honda G x 340 Engine	24 Volt Battery Pack 4 HP DC Electric Motor Four 220 Ampere Hour Batteries 11 HP Gas Honda G x 340 Engine	24 Volt Battery Pack 4 HP DC Electric Motor Four 220 Ampere Hour Batteries 11 HP Gas Honda G x 340 Engine	24 Volt Battery Pack 3 kW DC Motor Four 220 Ampere Hour Batteries 8.2 kW Gas Honda Engine	24 Volt Battery Pack 3 kW DC Motor Four 220 Ampere Hour Batteries 8.2 kW Gas Honda Engine	24 Volt Battery Pack 3 kW DC Motor Four 220 Ampere Hour Batteries 8.2 kW Gas Honda Engine
Battery Charger	25 AMP	25 AMP	25 AMP				
Battery Duty Cycle	25% for 8 Hours	25% for 8 hours	25% for 8 hours				
Hydraulic Tank Capacity	4 Gallons	4 Gallons	4 Gallons	15 Lit.	15 Lit.	15 Lit.	
Fuel Capacity Gas Power Option	1.9 Gallons	1.9 Gallons	1.9 Gallons	7.2 Lit.	7.2 Lit.	7.2 Lit.	
Lift System	Two Single Stage Lift Cylinders	Two Single Stage Lift Cylinders	Three Single Stage Lift Cylinders				
Drive Control	2 Speed, Forward and Reverse	2 Speed, Forward and Reverse	2 Speed, Forward and Reverse				
Control System	Toggle Switches for All Functions	Toggle Switches for All Functions	Toggle Switches for All Functions				
Horizontal Drive	Single Front Wheel Hydraulic Motor (Dual Optional)	Single Front Wheel Hydraulic Motor (Dual Optional)	Dual Front Wheel				
Tires	16 In. Diameter Solid Rubber	16 In. Diameter Solid Rubber (Opt. - 16.5x6.5x8 Urethane Filled)	16 In. Diameter Solid Rubber (Opt. - 16.5x6.5x8 Urethane Filled)	0.41 M. Diameter Solid Rubber	0.41 M. Diameter Solid Rubber (Opt. - 0.42x0.17 Urethane Filled)	0.41 Diameter Solid Rubber (Opt. - 0.42x0.17 Urethane Filled)	
Braking	Spring Applied, Hydraulic Release Parking Brake	Spring Applied, Hydraulic Release Parking Brake	Spring Applied, Hydraulic Release Parking Brake				
Turning Radius	24 In. Inside	24 In. Inside	24 In. Inside	0.61 M. Inside	0.61 M. Inside	0.61 M. Inside	
Gradeability	25%	25%	25%	14°	14°	14°	
Wheel Base	62 1/2 In.	63 In.	63 In.	1.59 M.	1.60 M.	1.60 M.	
Guardrails	42 In. High**	42 In. High	42 In. High	1.07 M.	1.07 M.	1.07 M.	
Toeboard	6 In. High	6 In. High	6 In. High	0.15 M.	0.15 M.	0.15 M.	
** Optional guardrails fold down to 79 In. for passage through 80 In. height door.				Optional guardrails 2.01 M. folded to pass through 2.03 M. door			
* Specifications subject to change without notice.							

UpRight

UpRight, Inc.
1775 Park Street
Selma, California 93662
TEL: 209/896-5150
FAX: 209/896-9012

Canada
108 Industrial Drive
Whitby, Ontario, Canada L1N5Z8
TEL: 416/668-7701

Call Toll Free

1-800-926-LIFT

Form No. IM-XL-C 2/91 P.N. 61999-002-00

SECTION III

PREPARATION FOR USE, SHIPMENT AND STORAGE

3-1. PREPARATION FOR USE.

WARNING

STAND CLEAR when cutting the metal banding to avoid being cut when the banding snaps back.

- Remove the metal banding from the module covers and elevating assembly.
- Remove the banding from the control console.
- Lift the front of XL-C Series work platform and remove banding and blocks from rear wheels.
- Lower work platform.
- Close the emergency lowering valve.
- Connect the negative battery lead terminal (1, Figure 3-1).

3-2. PREPARATION FOR SHIPMENT.

- Grease all the grease fittings as per Paragraph 5-8.
- Fully lower the platform.
- Disconnect the battery negative (-) lead from the battery terminal (1, Figure 3-1).
- Band the control console to the front guardrail.
- Band the scissor linkage to the frame just behind the front wheels and at the rear wheels.
- For sea shipment, perform preservation per extended storage paragraph 3-4/a.

3-3. TRANSPORT.

- Maneuver the XL-C into transport position and chock wheels.

NOTE

If forklifting is required, lift from side of the work platform.

- Place blocks under the front wheel yokes.
- Secure the work platform to the transport vehicle with chains or straps of adequate load capacity attached to the chassis tie down lugs.
- Open emergency lowering valve.

3-4. STORAGE. No preparation for storage is required for normal usage. Regular maintenance per Table 5-1 and Figure 5-1 should be performed. If the work platform is to be placed in long term storage (dead storage) use the following preservation procedure.

a. **Preservation.**

- Clean painted surfaces. If the paint surface is damaged, repaint.

NOTE

This hydraulic system is filled to the sight glass with approved fluid required for operation. Do not drain.

- Fill the hydraulic tank to operating level.
- Coat exposed portions of extended cylinder rods with an approved preservative and wrap with barrier material.
- Coat all exposed unpainted metal surfaces with preservative.

b. **Batteries.**

- Disconnect all the battery leads and secure to the chassis. Tape the connectors on the ends of the leads to the chassis.
- Remove the batteries and place in alternate service.

c. **Front Wheel Yokes.**

CAUTION

XL-C must be blocked under front wheel yokes to prevent damage to motor seals.

- Jack up front of work platform.
- Place blocks under front wheel yokes. The blocks must be high enough to prevent front tires from touching the ground.
- Lower work platform onto the blocks.

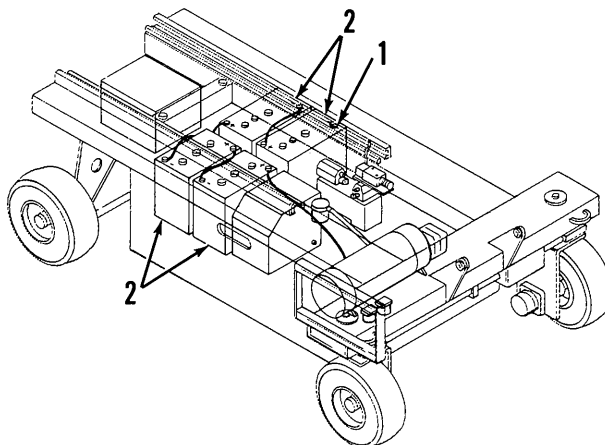

1. Negative Battery Terminal
2. Batteries

Figure 3-1. Batteries

OPERATION INSTRUCTIONS

4-1. THEORY OF OPERATION.

4-2. GENERAL FUNCTIONING. The battery powered electric motor directly drives a two section hydraulic pump. This pump supplies oil under pressure to operate all the work platform functions. The oil flow is directed to the different functions by electrically activated solenoid valves.

4-3. DRIVING (Figures 6-1 & 6-2). With the Emergency Stop Switch on and the Key Switch in drive the machine will drive and steer in the direction you wish to travel. Driving Forward or Reverse will energize the Drive Coils, the Steering Bypass Coil and the Motor Relays to start the Electric Motor. Oil will now flow through the Drive Valve to the Brake Cylinder and the Hydraulic Motors. Driving in High Speed will also energize the High Speed Coil. This allows oil to combine from both sections of the Hydraulic Pump and flow through Hydraulic Motors to increase speed. Steering Left or Right will energize the Steering Valve Coils and the Motor Relays. This allows oil to flow through the Steering Valve to the Steering Cylinder.

Driving in High Speed with platform elevated is the same, except the high speed check valve allows oil from one section of the pump to flow back to tank. This limits the machine to Low Speed.

4-4. RAISING AND LOWERING PLATFORM. With the Emergency Stop Switch on and the Key Switch in Lift, the platform will raise and lower. Raising the platform energizes the Lift Bypass Coil, Steering Bypass Coil, UP Coil and Motor Relays to start Electric Motor. Oil will now flow through the Lift Valve to the Lift Cylinder. Lifting in HIGH Speed will also energize the High Speed Coil. This allows oil to combine from both sections of Hydraulic Pump and flow to the Lift Cylinder, increasing the speed in which the platform will raise. Lowering the platform electrically energizes the Down Alarm and the Down Coil. This allows the oil to flow out of the Lift Cylinder through an orifice, which controls the rate of descent, then back to tank. Lowering the platform manually with Emergency Lowering Valve allows the oil to flow out of Lift Cylinder in same manner.

4-5. SAFETY DESIGN. The XL-C Series has the following features to ensure safe operation.

- The drive speed is limited to CREEP speed when operating the work platform while platform is elevated.
- The platform descent rate is controlled by an orifice. The lift cylinder is equipped with a velocity fuse to prevent descent should a hose fail.
- A holding brake is automatically engaged when the drive toggle switch is released.
- The control box is equipped with a guarded emergency-off switch.
- Controls are guarded to prevent inadvertent operating.
- An alarm is provided to signal when the platform is lowering.
- A lift switch is located in the module on the chassis for lifting and lowering work platform from ground level.
- A foot switch must be depressed for all powered functions.

4-6. CONTROLS AND INDICATORS. The controls and indicators for operation of the XL-C Series Work Platform are shown in Figure 4-1. The name and function of each control and indicator are listed in Table 4-1. The index numbers in the figure correspond to the index numbers in the table. The operator should know the location of each control and indicator and have a thorough knowledge of the function and operation of each before attempting to operate the unit.

4-7. OPERATING PROCEDURES.

4-8. PRE-OPERATION CHECKOUT.

WARNING

DO NOT perform service on work platform with the platform elevated unless it is properly blocked.

- Open module covers and inspect for damage and missing parts.
- Check the level of the oil with the platform fully lowered. Oil should be visible at the sight glass. Use Mobil 423 or equivalent.
- Check the fluid level in the batteries (See Section V, Paragraph 5-7).
- Check state of battery charge (See Section V, Paragraph 5-7/b).
- Check that A.C. extension cord has been disconnected from charger.
- Check that all guardrails are in place and secured with fasteners.
- Carefully inspect the entire work platform for damage such as cracked welds of structural members, loose or missing parts, oil leaks, damaged cables or hoses, loose connections and tire damage.

WARNING

Perform the following checks from the ground.

WARNING

STAND CLEAR of the platform while performing checks.

NOTE

Unhook control console from front guardrail and hold while performing the following tests.

- Before operating the work platform survey the work area for surface hazards such as holes, drop-offs, bumps and debris.
- Check in **ALL** directions for obstructions and electrical conductors.
- Lift the Emergency Stop Switch cover and position toggle to the **ON** position. (When switch guard is closed, Emergency Stop Switch will automatically go to **OFF** position).

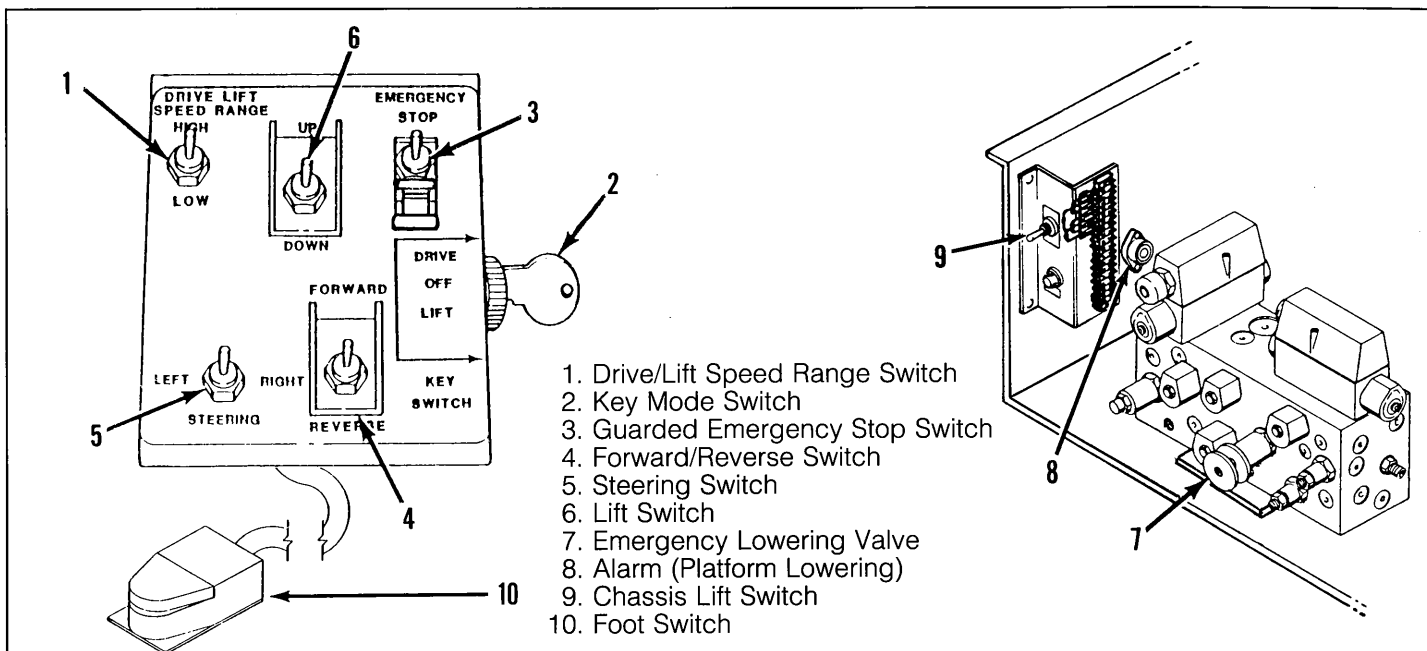

Figure 4-1. Controls and Indicators

CAUTION

Protect control console cable from possible damage while performing checks.

k. Turn Mode Switch to **DRIVE** position.

NOTE

Step I. should be performed with Speed Range Switch first in **LOW** and then **HIGH**.

NOTE

Foot switch must be depressed for all power functions.

l. Push Drive Switch to **FORWARD** position then **REVERSE** position to check for speed and direction control.

m. Move Steering Switch **RIGHT**. Then **LEFT** to check for steering control.

n. Rehook control console to front guardrail and turn Mode Switch to **LIFT**.

WARNING

LOOK up and around for obstructions prior to operating the lift function.

DO NOT operate the work platform within 10 feet of any electrical power lines. **THIS WORK PLATFORM IS NOT INSULATED.**

DO NOT elevate the platform unless the work platform is on firm level ground.

DO NOT enter the elevating assembly while the platform is elevated.

o. Push Chassis Lift Switch to **UP** position, check **LOW** and **HIGH** speeds and fully elevate platform.

p. Visually inspect the scissor linkage, rollers, lift cylinder, cables and hoses for damage or erratic operation. Check for missing or loose parts.

Table 4-1. Controls and Indicators

INDEX NUMBER	NAME	FUNCTION
1	Drive/Lift Speed Range Switch	Provides a High and Low Speed.
2	Key Mode Switch	Provides power to Drive Switches or Lift Switch.
3	Guarded Emergency Stop Switch	Cuts off power to all circuits.
4	Forward-Reverse Switch	Provides power to drive Valves.
5	Steering Switch	Provides power to Steering Valves. Although the switch is self-centering, the steering system is not. The wheels must be steered back to straight. Observe the tires while maneuvering the work platform to ensure proper direction.
6	Lift Switch	Provides power to Lift and Down Valves.
7	Emergency Lowering Valve	When Knob is turned counterclockwise to OPEN position, platform lowers. Valve is CLOSED by turning knob clockwise. The platform cannot be raise until the valve is closed.
8	Alarm (Platform Lowering)	Sounds an audible signal while platform is lowering when lift switch is used to lower the platform. If the Emergency Lowering Valve is used the alarm does not sound.
9	Chassis Lift Switch	Provides power for lifting and lowering platform at the ground level.
10	Foot Switch	Provides redundant electrical control switch

- q. Lower the platform partially by pushing Chassis Lift Switch to **DOWN**, and check operation of the audible lowering alarm.
- r. Open the Emergency Lowering Valve to check for proper operation. Once the platform is fully lowered, close the valve.
- s. Replace module covers.
- t. Turn Mode Switch to **OFF** and close Emergency Stop Switch Cover.

4-9. OPERATION.

4-10. TRAVEL WITH PLATFORM LOWERED (Figure 4-1).

- a. After entering platform latch gate across entrance. Also check that the middle of rear guardrail is pinned in position.
- b. Check that route is clear of obstructions, holes and drop-offs and is capable of supporting wheel loads.
- c. Check clearances above, below and to the sides of platform.
- d. Turn the Guarded Emergency Stop Switch (3) on the control console to the **ON** position.
- e. Turn Key Mode Switch (2) to **DRIVE**.
- f. Set the Drive/Lift Speed Range Switch to **LOW** or **HIGH** depending on area in which you are traveling.
- g. Depress foot switch.
- h. Push Forward/Reverse to **FORWARD** position or **REVERSE** position to travel in desired direction.
- i. Move the Steering Switch to **RIGHT** or **LEFT** to turn work platform.

NOTE

Steering is not self-centering. Wheels must be returned to straight ahead position by operating Steering Switch.

4-11. LIFTING PLATFORM.

WARNING

LOOK up and around for obstructions before performing the **LIFT** function.

DO NOT elevate the platform unless work platform is level.

DO NOT operate work platform within 10 feet of any electrical power lines. **THIS WORK PLATFORM IS NOT INSULATED.**

DO NOT perform service on work platform with the platform elevated, unless properly blocked.

- a. Turn Key Mode Switch to **LIFT** position.
- b. Depress foot switch.
- c. Push the Lift Switch to **UP** position and hold to elevate the platform.

WARNING

NEVER enter the elevating assembly while the platform is elevated.

- d. When the work task is completed, lower the platform by holding the Lift Switch in the **DOWN** position until the platform is fully lowered.

4-12. TRAVEL WITH PLATFORM ELEVATED (Figure 4-1).

NOTE

Work platform will travel at reduced speed when platform is elevated.

- a. Check that route is clear of persons, obstructions, holes and drop-offs and is capable of supporting the wheel loads.
- b. Check clearances above, below and to the sides of platform.
- c. Travel with platform elevated on hard level surface only.
- d. Turn Mode Switch to **DRIVE** position.

WARNING

BEFORE traveling in **REVERSE**, check that route is clear.

- e. Push Forward/Reverse to **FORWARD** or **REVERSE** for desired direction of travel.

4-13. XL-C FOLD DOWN GUARDRAILS (Figure 4-2).

a. Fold Down Procedure.

- (1) Remove control console from front guardrail and lay it on the platform deck.
- (2) Lift up on front top guardrail until slots disengage from pins. Fold guardrail back.
- (3) Remove retaining pin at right side of rear top guardrail rotate it to position along left top guardrail and pin in place.
- (4) Lift up on left top guardrail until slots disengage with pins and fold guardrail in.
- (5) Lift up on right top guardrail until slots disengage with pins and fold guardrail in.

b. Erection Procedure.

- (1) Raise the right top guardrail and push down to engage pins with slots.
- (2) Raise the left top guardrail and push down to engage pins with slots.
- (3) Remove retaining pin from rear top guardrail (attached to left top guardrail), swing it into place across rear of work platform and pin to right top guardrail.
- (4) Raise front top guardrail and push down to engage the pins with the slots.
- (5) Hook control console over front guardrail.

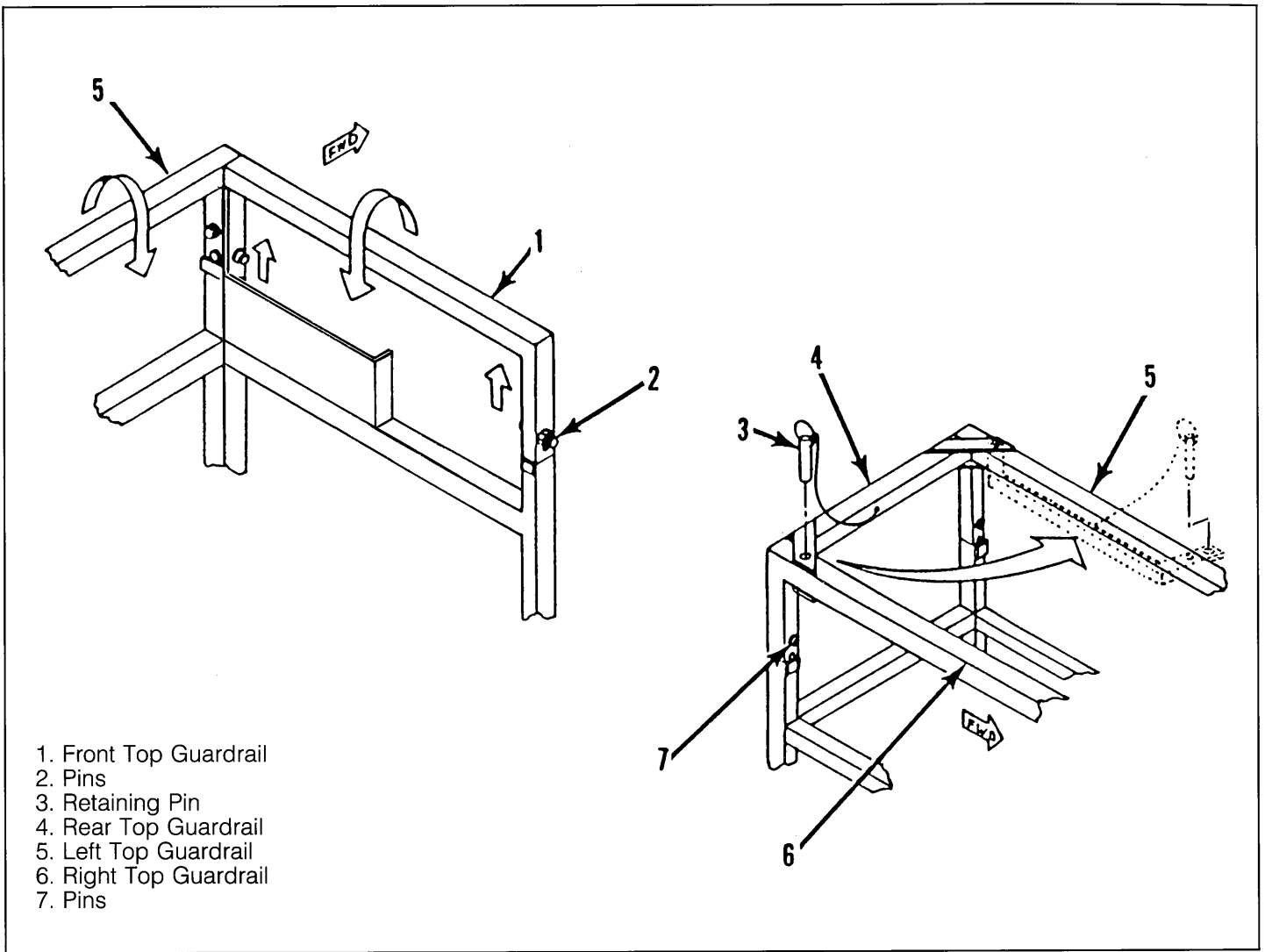

Figure 4-2. Fold Down Guardrails (XL-19C Shown. Other Models Similar)

SECTION V

MAINTENANCE INSTRUCTIONS

5-1. SCOPE. This section contains instructions for the maintenance of the XL-C Series Work Platform. Procedures for the operational checkout, adjustment, scheduled maintenance, troubleshooting, and repair/removal are included.

5-2. LOCATION OF COMPONENTS. Figure 5-1 shows components on complete work platform. Figure 5-2 shows components mounted directly to chassis and located in the control valve.

5-3. SCHEDULED INSPECTION AND MAINTENANCE.

5-4. GENERAL. The complete inspection consists of periodic visual and operational checks, together with all necessary minor adjustments to assure proper performance. Refer to Table 5-1.

5-5. BLOCKING SCISSORS (Figure 5-3).

WARNING

BEFORE performing maintenance service on work platform while platform is elevated ensure that elevating arms are properly blocked.

NOTE

A maintenance chock supplied with the platform shall be used to block the scissors.

a. Installation.

- (1) Park the work platform on firm, level ground.
- (2) Open Guarded Emergency Stop Switch Cover on control console and position toggle in the **ON** position.
- (3) Turn Key Mode Switch on control console to **LIFT** position.
- (4) Push Chassis Lift Switch (located in hydraulic module) to **UP** position and elevate platform approximately seven feet.

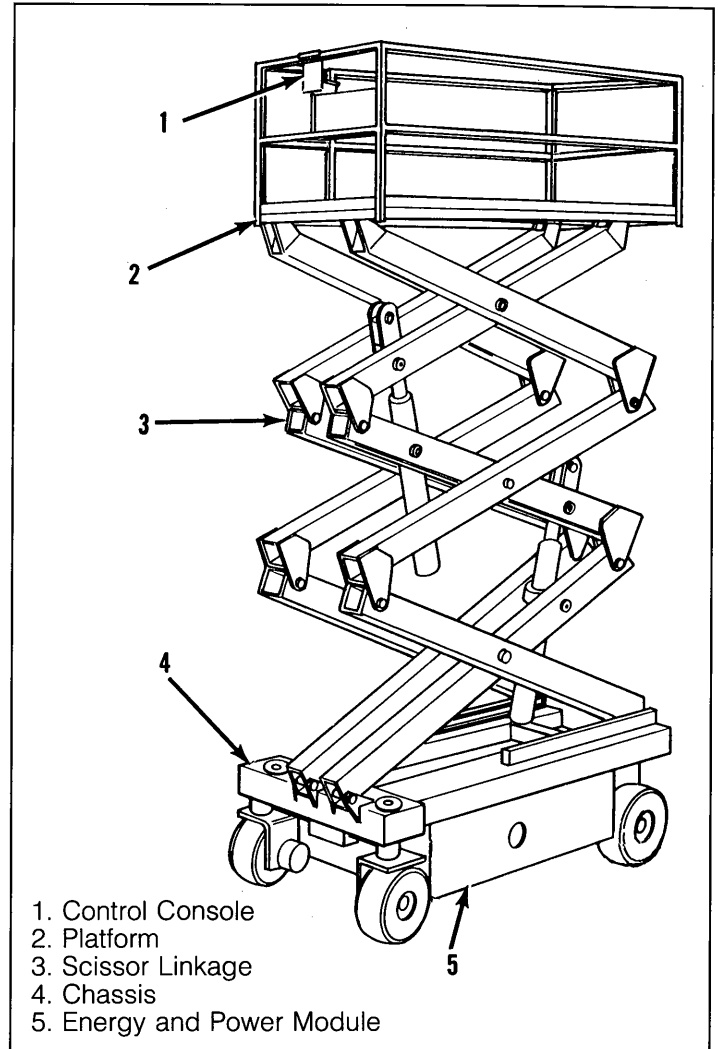
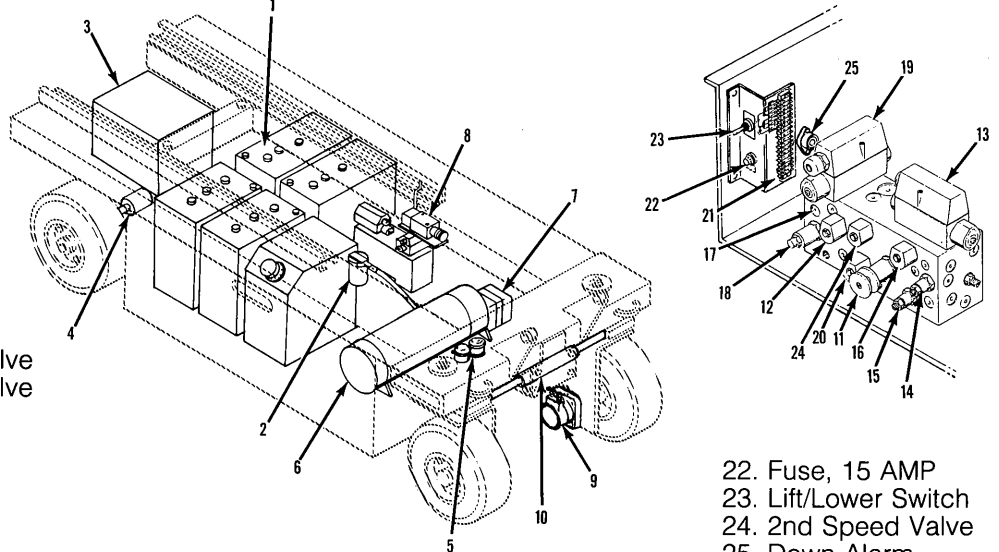

Figure 5-1. Location of Components

1. Battery
2. Return Filter
3. Battery Charger
4. Brake Cylinder
5. Motor Relay Kit
6. Electric Motor
7. Hydraulic Pump
8. Platform Height Limit Switch
9. Drive Motors
10. Steering Cylinders
11. Emergency Lowering Valve
12. Steering Bypass Valve
13. Forward/Reverse Valve
14. Reverse Counterbalance Valve
15. Forward Counterbalance Valve
16. Lift Valve
17. Gauge Port
18. Main Relief Valve
19. Steering Valve
20. Lift Bypass
21. Terminal Block



22. Fuse, 15 AMP
23. Lift/Lower Switch
24. 2nd Speed Valve
25. Down Alarm

Figure 5-2. Location of Components, Chassis

Table 5-1. Inspection, Checks and Services

INTERVAL	COMPONENT/LOCATION	INSPECTION/CHECK/SERVICES
Each Shift	Battery System/Chassis	Check electrolyte level. Check specific gravity. Clean exterior. Check cable condition. Charge batteries per paragraph 5-7/b.
	Hydraulic Oil Tank/Chassis	Check oil level and fill if necessary.
	Tires/Chassis	Check for damage.
	Control Linkage Cable/Scissors	Check the exterior of the cable for pinching, binding or wear.
	Deck and Guardrails/Platform	Check fasteners for proper torque. Check welds for cracks. Check condition of deck.
	Arms/Scissors	Inspect for structural bends and weld cracking.
125 Hours	Control Valves/Hydraulic System	Check for leaks at valve bases. Check valve hose connections.
	Hoses/Hydraulic System	Check hose connections for serviceability. Check hoses for wear.
	Emergency Hydraulic System/Chassis Module	Open emergency lowering valve and check for serviceability.
	Hydraulic Pump/Chassis	Check for leaks at mating surfaces. Check for hose fitting leaks. Check mounting bolts for proper torque.
	Drive Motors/Chassis	Check for operation and leaks.
	Steering System/Chassis	Check hardware for proper torque
	Steering Cylinders/Chassis	Check rods for wear. Check Seals for leakage. Check hoses for damage. Check fittings for proper torque.
	Wheel Bearings/Chassis	Check wheel assembly for play.
	Pivot Pin Retainer/Scissors	Check bolts for proper torque.
	Lift Cylinder/Hydraulic System	Check rod for wear. Check mounting pivot pins for wear. Check seals for leaks. Check hoses for damage. Check fittings for proper torque. Check snaprings.
	Control Console/Platform	Check switch operation. Check cable for wear.
	Work Platform, Complete	Perform pre-operational checkout per paragraph 4-8.
	Work Platform, Complete	Lubricate per paragraph 5-8

INTERVAL	COMPONENT/LOCATION	INSPECTION/CHECK/SERVICES
250 Hours	Batteries/Chassis	Clean terminals per paragraph 5-7/a.
	Hydraulic Oil Filter/Chassis	Change filter per paragraph 5-9.
	Hydraulic Pump/Chassis	Wipe clean.
	Steering System/Chassis	Check hardware.
	Pivot Points/Scissors Rollers and Tracks/Scissors	Check for wear. Check for wear and deformation.
	Arm/Scissors	Check for bending and weld cracks.
500 Hours	Entire Work Platform	Check component mountings for proper torque. Check all fasteners for proper torque. Check welds for cracks. Check hoses for physical damage. Check for and repair collision damage.
	Entire Work Platform	Check for corrosion, remove and repaint.
1000 Hours	Hydraulic Oil/Chassis	Drain hydraulic tank and replace oil per paragraph 5-8.
	Wheel Bearings/Chassis	Repack wheel bearings per seals per paragraph 5-20
2000	Wheel Bearings/Chassis	Repack wheel bearings per seals per paragraph 5-20

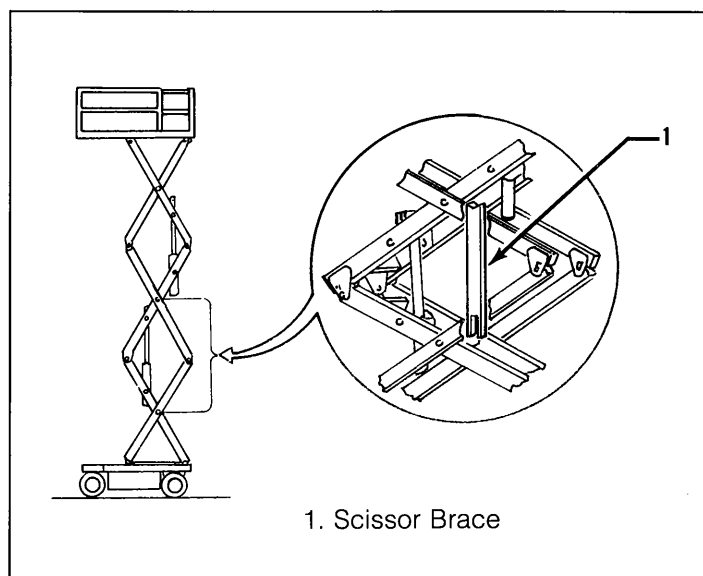

Figure 5-3. Blocking the Scissors

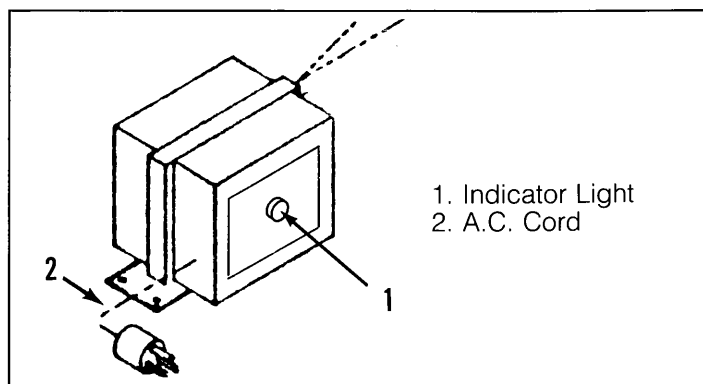

Figure 5-4. Battery Charger

WARNING

DO NOT stand in scissors area while performing steps 5 and 6.

- (5) Rotate the scissors brace between center pivot assembly of middle scissors arms.
- (6) Push Chassis Lift Switch to **DOWN** position and gradually lower scissors until center of scissor arm weldment rests on brace.

b. Removal.

WARNING

DO NOT stand in scissors area while disengaging scissors brace.

- (1) Push Chassis Lift Switch to **UP** position and gradually raise platform until center of scissors arm weldment clears flange of scissor brace.
- (2) Rotate scissor brace forward to rest on cross angle.
- (3) Push Chassis Lift Switch to **DOWN** position and completely lower platform.
- (4) Turn Key Mode Switch to the **OFF** position and close Guarded Emergency Stop Switch Cover.

5-6. MAINTENANCE-DETAIL INSTRUCTIONS.

5-7. BATTERY MAINTENANCE. Electrical energy for the motor is supplied by four six volt batteries wired in series for 24 volts DC. Proper care and maintenance of the batteries and motor will ensure maximum performance from the work platform.

a. Battery Inspection and Cleaning.

- (1) Check battery fluid level daily, especially if work platform is being used in a warm, dry climate.

CAUTION

If battery water level is not maintained, batteries are not capable of full charge therefore creating a low discharge rate which will damage motor/pump unit and void warranty.

- (2) Batteries and cables should be inspected periodically for signs of cracks in the cases, electrolyte leakage and corrosion of the terminals. Inspect cables for worn spots or breaks in the insulation and for broken cable terminals.
- (3) Clean batteries which show signs of corrosion at the terminals, or onto which electrolyte has overflowed during charging. Use a baking soda or ammonia solution to clean the batteries, taking care not to get the solution inside the cells. Rinse thoroughly with clear water. Clean battery and cable contact surfaces to a bright metal finish whenever a cable is removed.

b. Battery Charging (See Figure 5-4).

- (1) Charge batteries at end of each work shift or sooner if batteries have been discharged.

CAUTION

Do not charge batteries when the work platform is in a hazardous area.

CAUTION

Permanent damage to batteries will result if batteries are not immediately recharged after discharging.

- (2) Do not charge unused vehicles regularly except during winter storage on a monthly basis.
- (3) When night air temperatures fall below 65 degrees F batteries charged in unheated areas should be placed on charge as soon after use as possible. Under such conditions a 4 hour equalize charge once a week in the early afternoon will improve state of charge and battery life.
- (4) Connect A.C. Cord (2) to a properly grounded 115 volt, 60Hz power supply.
- (5) LED glows to indicate battery being charged.
- (6) LED blinks when batteries are at full charge.

c. Battery Cell Equalization.

- (1) Once a month, the specific gravity of all cells should be checked with a hydrometer. The temperature corrected specific gravity in this state should be 1.260. If any corrected readings are below 1.230, the batteries containing such cells should be replaced. If a wide variation exists, this is an indication for need of battery replacement.
- (2) Do not check the specific gravity in a cell to which water has just been added. If there is not enough electrolyte in a fully charged cell to obtain a sample for the hydrometer, add water and continue charging for one to two hours to adequately mix the water and electrolyte.

5-8. LUBRICATION. Refer to Figure 5-5 for location of items that require lubrication service.

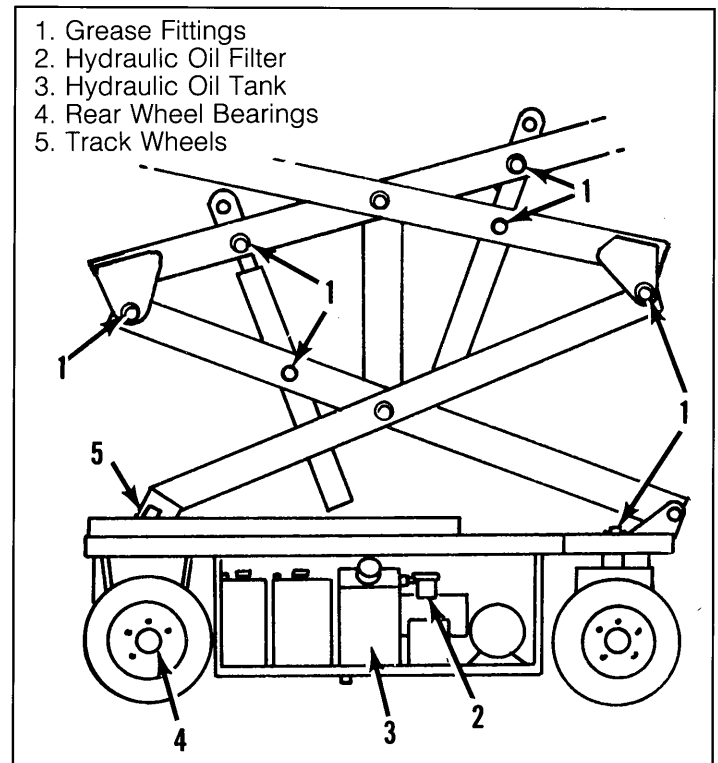

Figure 5-5. Lubrication Points

5-9. HYDRAULIC OIL TANK AND FILTER (Figure 5-6).

- a. Operate the work platform to bring the hydraulic oil up to normal operating temperature.
- b. Provide a suitable container to catch the drained oil. Hydraulic tank has a 4 gallon capacity.

WARNING

The hydraulic oil may be of sufficient temperature to cause burns. Wear safety gloves and safety glasses when handling hot oil.

- c. Remove the drain plug and allow all oil to drain.
- d. Reinstall the drain plug.
- e. Unthread the filter top from the filter head.
- f. Apply a thin film of clean hydraulic oil (Mobil 423 or equivalent) to the gasket of the replacement filter.
- g. Thread the replacement filter onto the filter head until the gasket makes contact then rotate the filter 3/4 of one turn further.
- h. Fill the hydraulic reservoir to the sight gauge with Mobile 423 hydraulic oil or equivalent. Hydraulic tank has a 4 gallon capacity.

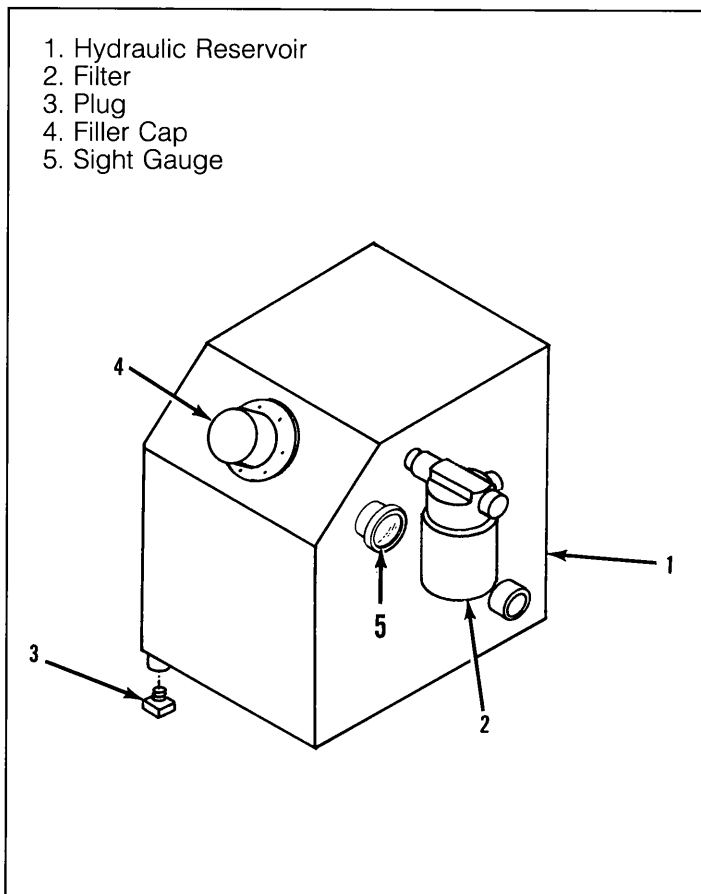

Figure 5-6. Hydraulic Oil Tank and Filter

5-10. TROUBLESHOOTING.

5-11. SCOPE. Table 5-2 provides a logical sequence of tests that are designed to isolate problems with XL-C Series machine. This table includes a list of probable causes and remedies.

5-12. SAFETY.

WARNING

When troubleshooting, ensure that the work platform is resting on a firm, level surface. When performing any service which requires the platform to be raised, the sissors must be blocked per paragraph 5-5. Disconnect the batteries when replacing or testing the continuity of any electrical component.

5-13. GENERAL PROCEDURE. Troubleshooting should be carried out in two steps, first by thoroughly looking at the electrical circuits and components that could cause the problem. Loose terminal connections and short circuits are always a potential probable cause when troubleshooting. Secondly, the hydraulic system should be examined, but only after electrical circuits and components have been found fault free. Refer to Tables 6-1 and 6-2 for Reference Designations used in Table 5-2.

Table 5-2. Troubleshooting

TROUBLE	PROBABLE CAUSE	REMEDY
All functions inoperable, electric motor does not start.	1. Blown control circuit fuse.	Check 15 amp Control Circuit Fuse (F1). Replace if blown.
	2. Faulty battery charger.	Check the voltage output of the battery charger. If less than 24 VDC, repair or replace.
	3. Faulty battery (ies).	After completely charging the batteries, test each battery (BT). Replace as required.
	4. Faulty electric motor.	While operating the steering function, check voltage across the Electric Motor (B) terminals. If 24 VDC is present, replace the Motor (B).
	5. Faulty motor relay(s).	While operating the steering, check voltage across the coil terminals of Motor Relay (CR1, CR2). If no voltage is present, proceed with step 6. If 20 VDC or more, check continuity across the contact terminals of Motor Relay (CR1, CR2) while still operating the steering function. If there is no continuity, replace the defective Motor Relay (CR1, CR2).
	6. Guarded emergency stop failed open.	With the Guarded Emergency Stop Switch (S1) in the ON position, check continuity across the contacts. If none, replace.

Table 5-2. Troubleshooting

TROUBLE	PROBABLE CAUSE	REMEDY
All functions inoperable. Electric motor starts when control is actuated.	1. Hydraulic reservoir low.	Check hydraulic fluid level, top off as required.
	2. Damaged coupling.	Remove Pump (ASSY1) from Motor (B) and check coupling.
	3. Faulty hydraulic pump.	Check pressure and delivery of the Hydraulic Pump (ASSY1). Replace if required.
Electric Motor starts but no functions in low speed.	CV2	Check CV2 for contaminants and reset check ball in valve block.
Electric Motor continues to run after controls are returned to the OFF position.	Motor relay contacts fused together.	With 0 voltage at the coil terminals of the Motor Relay (CR2) check continuity across the contact terminals. If there is continuity, replace the Motor Relay (CR1 and/or CR2).
Work platform will not drive or steer. Platform Up/Down functions properly.	Faulty key mode switch	With the Key Mode Switch (S2) in the DRIVE position, check continuity. Replace if faulty.
Steering inoperable or functions sluggishly.	1. Faulty steering switch.	Test Steering Switch (S4) for continuity. Replace if faulty.
	2. Faulty key mode switch.	Test Key Mode Switch (S2) for continuity. Replace if faulty.
	3. Faulty Diode (D3).	Check diode (D3) replace if faulty.
	4. Mechanical damage.	Inspect all steering components. Replace damaged parts.
	5. Steering valve stuck.	Inspect Steering Valve (V1). If spool is sticking, replace.
	6. Steering Cylinder piston seal leaking.	Check Steering Cylinder (CYL3) for leakage from one port to another. Repair as required.
Work platform will not steer right.	1. Faulty steering switch.	Test Steering Switch (S4) for continuity. Replace if faulty.
	2. Faulty diode.	Test Diodes (D1, D2). Replace if faulty.
	3. Faulty steer right solenoid.	Test Steer Right Solenoid (L1). If the proper voltage is present and the Coil is not magnetic, replace.

Table 5-2. Troubleshooting - Continued

TROUBLE	PROBABLE CAUSE	REMEDY
Work platform will not steer left.	1. Faulty steering switch.	Test Steering Switch (S4) for continuity. Replace if faulty.
	2. Faulty diode.	Test Diodes (D1, D2) Replace if defective.
	3. Faulty steer left solenoid.	Test Steer Left Solenoid (L2). If the proper voltage is present and the Coil is not magnetic, replace.
Work platform will not drive forward or reverse. Lift function operable.	1. Faulty drive switch.	Check continuity of Drive Switch (S5).
	2. Faulty key mode switch.	Check continuity of Key Mode Switch (S2).
	3. Faulty diode.	Check Diode (D3) replace if faulty.
	4. Forward/reverse valve faulty.	Check the Forward/Reverse Valve (V4). If the spool is not shifting, replace the valve.
	5. Shuttle valve not seating.	Check for contaminants and reseal ball to valve block.
	6. Mechanical failure.	Inspect drive motor shafts, hubs, and keys.
	7. Worn drive motors.	Check hydraulic pressure being delivered to the Drive Motors (MOT1, MOT2). If sufficient, replace Drive Motors.
No drive in HIGH speed.	1. Lift cylinder has pressure on them.	Check to make sure platform is completely lowered.
	2. Faulty speed range switch.	Test Speed Range Switch (S6) for continuity. Replace if faulty.
	3. Faulty High speed coil.	Test High Speed Coil (L9). If proper voltage is present and coil is not magnetized, replace.
	4. Faulty High speed valve.	Replace High Speed Valve (V8).
	5. CV4	Check CV4 for contaminants and reseal in valve block.
No drive FWD but drives in REV .	1. Faulty drive switch.	Test Drive Switch (S5) for continuity. Replace if faulty.
	2. Faulty diode.	Test Diodes (D4, D5). Replace if faulty.
	3. Faulty FWD coil.	Test FWD Coil (L3) if proper voltage is present and coil is not magnetized, replace.

Table 5-2. Troubleshooting - Continued

TROUBLE	PROBABLE CAUSE	REMEDY
No drive FWD but drives in REV. Continued	4. Faulty drive valve.	Inspect Drive Valve (V4) if spool is sticking replace.
	5. Faulty counter-balance valves.	Check pressure of Counter-balance Valves (V2, V3). Replace or reset valves as required.
	6. Shuttle valve.	Check for contaminants and reseal ball in Valve Block.
No drive REV but drives in FWD.	1. Faulty drive switch.	Test Drive Switch (S5) for continuity. Replace if faulty.
	2. Faulty diode.	Test Diodes (D4, D5). Replace if faulty.
	3. Faulty REV coil.	Test REV Coil (L5) if proper voltage is present and coil is not magnetized, replace.
	4. Faulty drive valve.	Inspect Drive Valve (V4) if spool is sticking replace.
	5. Faulty counter-balance valves.	Check pressure of Counter-balance Valves (V2, V3). Replace or reset valves as required.
	6. Shuttle valve.	Check for contaminants and reset ball in Valve Block.
Platform will not elevate or elevates slowly in LOW and HIGH speeds.	1. Emergency down valve open.	Close Emergency Down Valve (V10)
	2. Platform overload.	Observe maximum load rating (See Table 1-1).
	3. Faulty diode.	Test Diode (D6), replace if faulty.
	4. Faulty lift valve coil.	Test Lift Valve Coil (L6). If proper voltage is present and the coil is not magnetized, replace.
	5. Height limit switch malfunction.	Test Height Limit Switch (S8) for continuity. Replace if required.
	6. Faulty lift switch.	While holding the Lift Switch (S3) in the LIFT position, check continuity. Replace if faulty.
	7. Faulty key mode switch.	Test Key Mode Switch (S2) for continuity. Replace if defective.
	8. Relief valve out of adjustment or faulty.	Adjust the Main Relief Valve (RV1). If not adjustable, replace.
	9. Lift valve sticking.	Replace the Lift Valve (V7).
	10. Lowering valve stuck in the OPEN position.	Replace the Lowering Valve (V11).

Table 5-2. Troubleshooting - Continued

TROUBLE	PROBABLE CAUSE	REMEDY
No drive or lift in LOW speed but steering OK.	1. Faulty steering bypass coil.	Test Steering Bypass Coil (L4). If proper voltage is present and coil is not magnetized replace.
	2. Faulty Steering bypass valve.	Replace Steering Bypass Valve (V6).
No lift in HIGH speed.	1. Faulty speed range switch.	Test Speed Range Switch (S6) for continuity. Replace if faulty.
	2. Faulty High speed coil.	Test High Speed Coil (L9) if proper voltage is present and the coil is not magnetized, replace.
	3. Faulty Lift Bypass Coil.	Test Lift Bypass Coil (L7) if proper voltage is present and the coil is not magnetized, replace.
	4. Faulty High speed valve.	Replace High Speed Valve.
	5. Faulty lift bypass valve.	Replace Lift Bypass Valve.
Platform drifts down after being elevated.	1. Emergency down valve partly open or faulty.	Ensure that the Emergency Down Valve (V10) is completely closed. If the platform still drifts down, replace the Emergency Lowering Valve (V10).
	2. Check valve leaking.	Check for contamination under Ball (CV3). Clean and reseal Ball in block.
	3. Leaky down valve cartridge.	Replace the Down Valve (V11).
	4. Faulty Valve O-rings.	Check and replace O-Rings on Emergency Lowering Valve (V10) Lowering Valve (V11) and Piston.
Work platform drives while lifting.	Faulty diode.	Test Diode (D4, D5). Replace if faulty.
Work platform lifts while driving.	Faulty diode.	Test Diode (D6). Replace if faulty.
Platform will not lower.	1. Faulty lowering valve coil.	Test Lowering Valve Coil (L8). If proper voltage is present and Coil is not magnetized, replace.
	2. Faulty key mode selector switch.	With the Key Mode Selector Switch (S2) in the LIFT position, check continuity. Replace if defective.
	3. Faulty lift switch.	While holding the Lift Switch (S3) in the DOWN position, check continuity. Replace if defective.
	4. Lowering valve stuck.	Replace the Lowering Valve (V11).
	5. Plugged lowering speed orifice.	Replace and clean Orifice (ORF2).
	6. Velocity fuse valve sticking.	Replace the Velocity Fuse Valve (V5).

Table 5-2. Troubleshooting - Continued

TROUBLE	PROBABLE CAUSE	REMEDY
Down alarm horn does not sound.	Faulty down alarm horn.	Check voltage to Down Alarm Horn. If proper voltage is present, replace the Down Alarm Horn (HN).
Brake will not release.	Faulty brake cylinder.	Check and replace Seals in Brake Cylinder (CYL2).
Brake will not lock wheel.	1. Orifice plugged.	Remove and clean Brake Orifice (ORF1).
	2. Faulty brake cylinder.	Check and replace Seals in Brake Cylinder (CYL2).

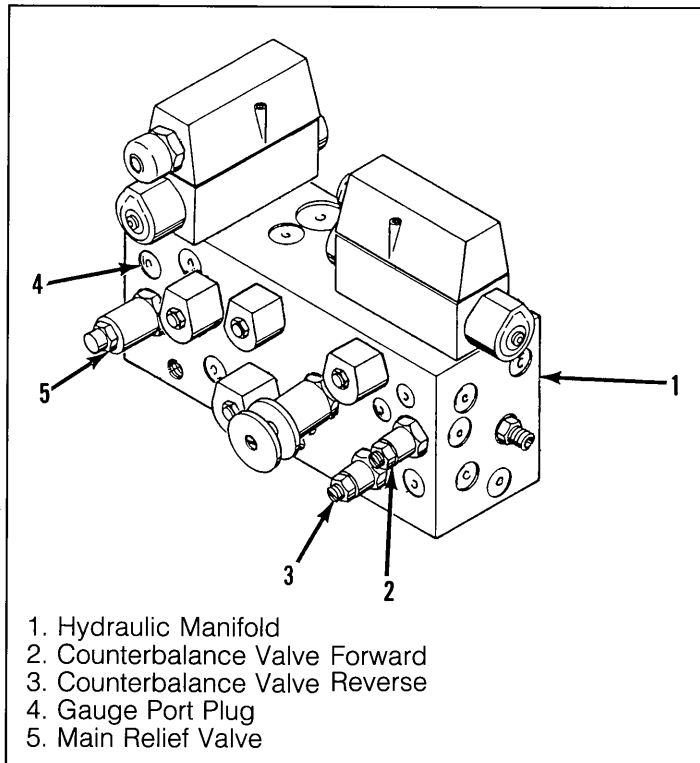

Figure 5-7. Hydraulic Pressure Adjustment

5-14. ADJUSTMENTS.

5-15. SETTING HYDRAULIC PRESSURE (Figure 5-7).

NOTE

Check the hydraulic pressure whenever the manifold or relief valve has been serviced or replaced.

a. Main Relief Valve.

- (1) Operate the hydraulic system 10-15 minutes to warm the oil.
- (2) Remove the plug in the Gauge Port and install a 0-3000 psi pressure gauge.
- (3) Disconnect one of the quick-disconnect connectors in the Lift Limit Switch wires (located by terminal block).
- (4) Loosen the locknut on the Main Relief Valve.

- (5) Position the Chassis Lift Switch to **UP** position and hold it there.
- (6) Slowly screw the adjusting screw in to increase the pressure to raise the rated platform load, then tighten the locknut.
- (7) Reconnect the Lift Limit Switch wire.
- (8) Remove pressure gauge and install plug

b. Counterbalance Valve.

- (1) Remove Gauge Port Plug and install an 0-1000 psi pressure gauge.
- (2) Lift work platform and block rear wheels off ground.
- (3) Operate the hydraulic system 10 to 15 minutes to warm the hydraulic oil.
- (4) Position the Key Mode Switch to **DRIVE**.
- (5) Position Speed Range Switch to **LOW**.
- (6) Position the Drive Switch to **FORWARD**.
- (7) Adjust the **REVERSE** Counterbalance Valve by turning the adjustment screw **OUT** until the pressure gauge indicates 400 psi, then slowly turn the screw **IN** until the gauge indicates 300 psi for XL-19C & XL-19CW and 350 psi for XL-24C & XL-24CW. Lock adjustment with locknut.
- (8) Position the Drive Switch to **REVERSE**.
- (9) Adjust the **FORWARD** Counterbalance Valve by turning the adjustment screw **OUT** to achieve 400 psi, then slowly turning the screw **IN** to reach 300 psi for XL-19C & XL-19CW and 350 psi for XL-24C & XL-24CW. Lock the adjustment with the locknut.
- (10) Position Drive Switch **FORWARD**, then position Drive Switch in **REVERSE** checking gauge to ensure pressures are 300 psi for XL-19C & XL-19CW and 350 psi for XL-24C & XL-24CW. Readjust as needed.
- (11) Remove blocks and lower work platform to ground.
- (12) Remove the gauge from the gauge port and reinstall plug.
- (13) Operate the drive system and check proper speeds and braking.

5-16. REPAIR. The following procedures are to handle replacement of components that are damaged or worn beyond acceptable performance specifications.

5-17. HYDRAULIC MANIFOLD (Figure 5-8).

a. General. Though it is not necessary to remove the manifold to perform all maintenance procedures, a determination should be made prior to beginning as to whether or not the manifold should be removed before maintenance procedures begin.

b. Removal.

- (1) Tag and disconnect the solenoid valve leads from the terminal strip.
- (2) Tag, disconnect and plug hydraulic hoses.
- (3) Remove the ESNA nuts, jam nut and bolts that hold the manifold to the mounting bracket.
- (4) Remove manifold block.

c. Disassembly.

NOTE

Mark all components as they are removed so as not to confuse their location during assembly.

- (1) Remove coils from solenoid valves.
- (2) Remove solenoid valve and fitting.
- (3) Remove spool valve covers and spool valves.

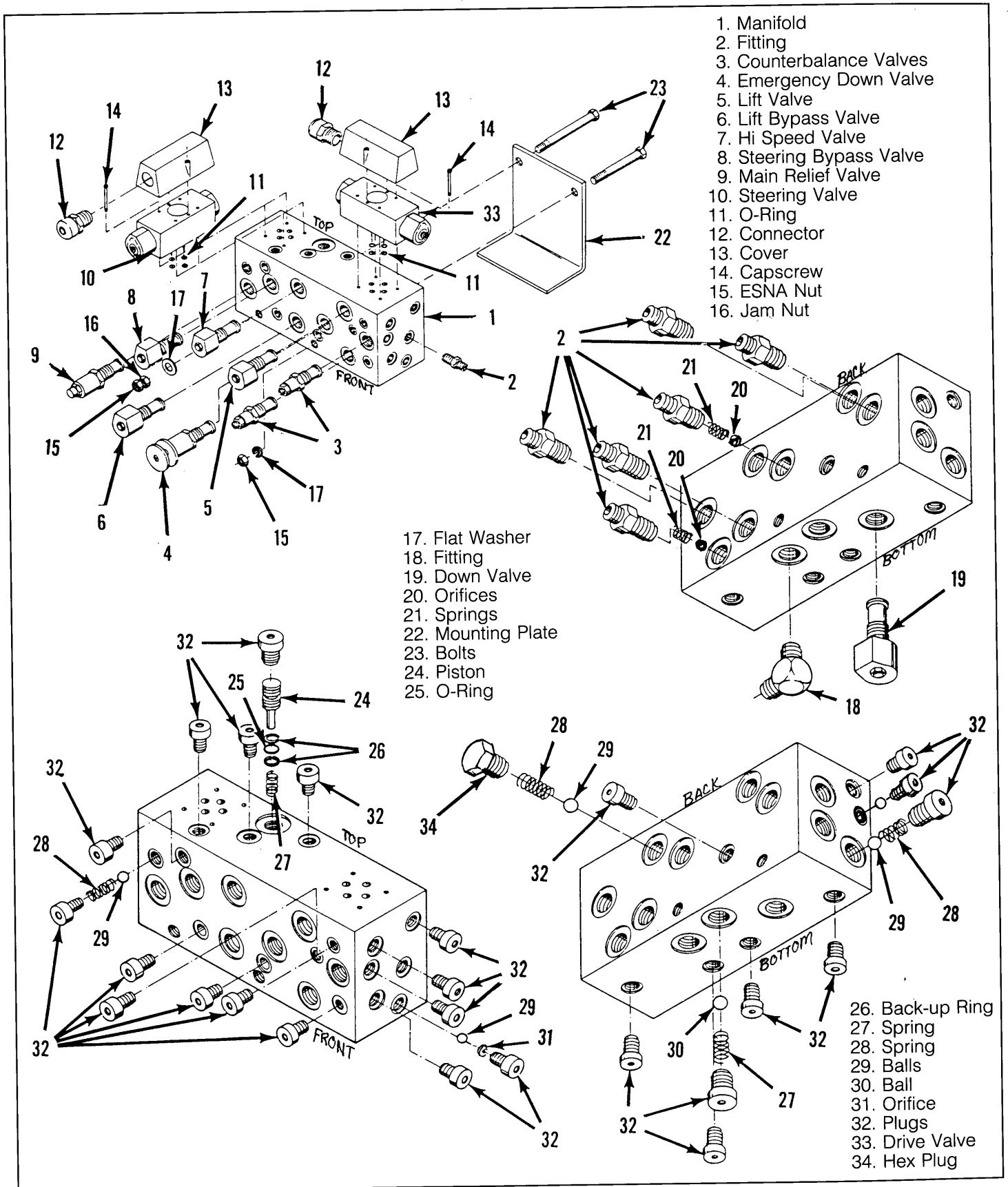

Figure 5-8. Hydraulic Manifold

061799-001

- (4) Remove solenoid valves, main relief valve, counterbalance valves and emergency down valve.
- (5) Remove fittings, springs and orifices.
- (6) Remove plugs, spring and ball from back side of manifold block.
- (7) Remove plugs, spring and ball from left side of manifold block. (2 places)
- (8) Remove plugs, spring and ball from bottom of manifold block.
- (9) Remove plugs, spring and ball from front of manifold block.
- (10) Remove plugs, orifice and ball from right side of manifold block.
- (11) Remove plugs, piston and spring from top of manifold block.

d. Cleaning and Inspection.

- (1) Wash the manifold in cleaning solvent to remove built up contaminants and then blow out all passages with clean compressed air.
- (2) Inspect the manifold for cracks, thread damage and scorings where O-rings seal against internal and external surfaces.
- (3) Wash and dry each component and check for thread damage, torn or cracked O-rings and proper operation.
- (4) Replace parts and O-rings found unserviceable.

e. Assembly.

NOTE

Lubricate all O-rings before installation to prevent damage to O-rings. Seat all balls in manifold block.

- (1) Install spring, piston and plugs in top of manifold block.
- (2) Install ball, orifice (use one drop of locktite #242) and plugs to right side of manifold block.
- (3) Install ball, spring and plugs to front side of manifold block.
- (4) Install ball, spring and plugs to bottom of manifold block.
- (5) Install ball, spring and plugs to back of manifold block.
- (6) Install ball, spring and plugs to left side of manifold block.
- (7) Install orifices, spring and fittings to back and right side of manifold block.
- (8) Install emergency lowering valve, counterbalance valves, main relief valve and solenoid valves to front side of manifold block.
- (9) Install spool valves to top of manifold block.
- (10) Install fitting.
 - (11) Install coils to solenoid valves.

f. Installation.

- (1) Attach manifold assembly to mounting plate with bolts, jam nut and ESNA nut.

NOTE

Longer bolt and jam nut go in hole nearest the front of the module.

Attach all solenoid ground wires with ESNA nut.

- (2) Connect Solenoid leads to terminal strip (as previously tagged).
- (3) Connect hydraulic hoses. Be certain to tighten hoses to manifold.
- (4) Operate each hydraulic function and check for proper function and leaks.

5-18. HYDRAULIC PUMP (Figure 5-9).

a. Removal (Figure 5-9).

NOTE

If the hydraulic tank has not been drained, suitable means for plugging the hoses should be provided to prevent excessive fluid loss.

- (1) Mark, disconnect and plug the hose assemblies.
- Loosen the capscrews and remove the pump assembly from the motor. Ensure not to loose the shaft coupler.

b. Installation.

- (1) Lubricate the pump with general purpose grease and attach the pump to the motor with the capscrews.
- (2) Use a criss-cross pattern and torque each capscrew a little at a time until all 4 capscrews are torqued to 20 ft. lbs.
- (3) Unplug and reconnect the hydraulic hoses.
- (4) Check the oil level in the hydraulic tank before operating the work platform.

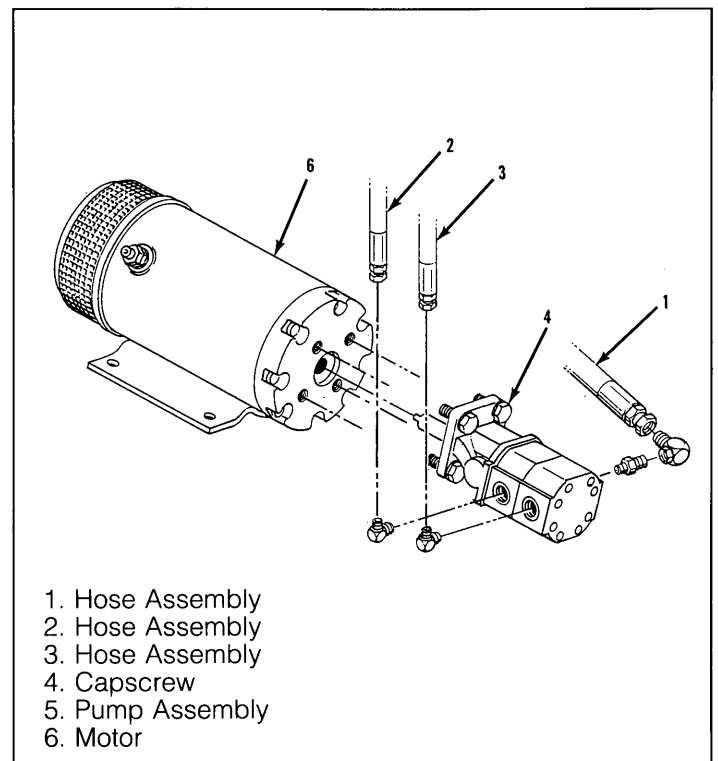

Figure 5-9. Hydraulic Pump Removal

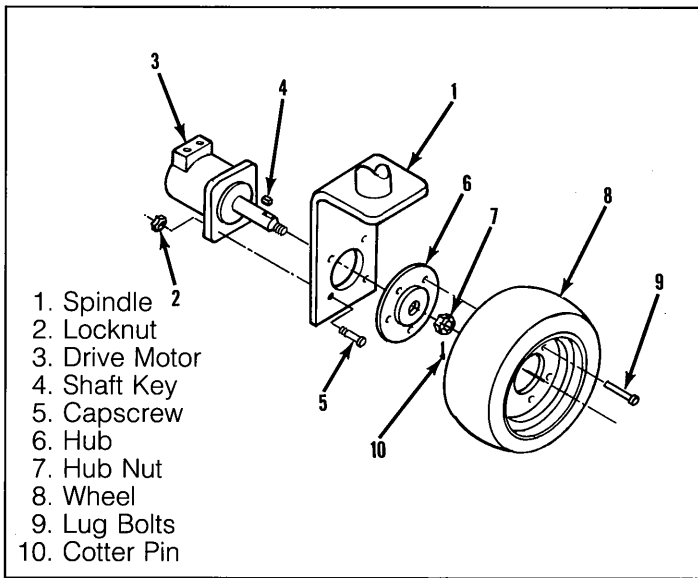

Figure 5-10. Drive Motor Removal

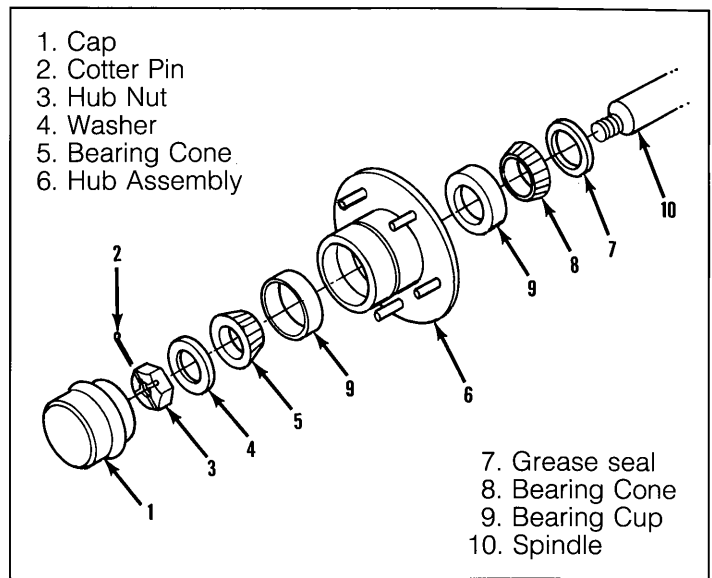

Figure 5-11. Wheel Bearings

5-19. HYDRAULIC DRIVE MOTORS AND HUBS.

a. Removal (Figure 5-10).

- (1) Park the work platform on firm level ground then block the wheels to prevent the work platform from rolling.
- (2) Loosen the wheel lug bolts on the front corner to be raised.
- (3) Use a 1.5 ton capacity jack to raise the desired front corner.

WARNING

Position blocks under the raised corner to prevent the work platform from falling if the jack fails.

- (4) Remove the wheel lug bolts and wheel.
- (5) Remove the cotter pin, locknut, hub and the shaft key.

NOTE

Before disconnecting hoses, thoroughly clean off all outside dirt around fittings. (After disconnecting hoses and before removing from vehicle, **IMMEDIATELY** plug port holes.)

- (6) Tag, disconnect and plug the hose assemblies to prevent foreign material from entering.
- (7) Remove the locknuts, capscrews and drive motor from the yoke.

b. Installation.

- (1) Refer to Figure 5-10 and position the drive motor on the yoke and secure with capscrews and locknuts.
- (2) Remove the plugs from the tube assemblies and connect to the drive motor.
- (3) Install the shaft key, hub and slotted nut. Torque the locknut to 350 to 400 ft. lb. Install the cotter pin.
- (4) Install the wheel with capscrews onto the hub. Torque to 40 ft. lb.
- (5) Lower the jack and remove. Operate the drive system and check for leaks.

5-20. WHEEL BEARINGS (Figure 5-11).

a. Removal.

- (1) Loosen the wheel lug nuts then raise the work platform until the tire to be worked on is off the ground.
- (2) Install support blocks to prevent the work platform from falling if the jack fails.
- (3) Remove the wheel lug nuts and the wheel.
- (4) Remove the cap.
- (5) Straighten the cotter pin then withdraw it from the spindle and hub nut.
- (6) Remove the hub nut and washer.
- (7) Slide the entire hub assembly from the spindle and place on clean surface.
- (8) Remove the bearing cone and place on clean surface.
- (9) Remove the grease seal thus allowing the bearing cone to be removed.

NOTE

At this point, examine the bearing cups. If they are smooth, shiny and free of pits or any surface irregularities, **DO NOT** remove them.

- (10) If the bearing cups need replacement, remove them by tapping around the circumference of the inside surface of the cups from the opposite side using a long drift.

b. Installation.

- (1) Position the replacement bearing cup over the opening in the hub assembly then position the worn cup over the replacement so that the bearing surfaces face each other. Use the old bearing cup as a drift to work the replacement into position by tapping evenly around the circumference.
- (2) Apply a liberal coating of multi purpose grease to the bearing surface of each cup.
- (3) Pack the bearing cone with multi purpose grease and position it within the rear bearing cup in the hub

assembly install the new grease seal again using the worn bearing cup as a drift.

- (4) Apply a thin coating of multi purpose grease to the spindle to protect the grease seal then slide the hub assembly onto the spindle.
- (5) Pack the bearing cone with multi purpose grease and slide it onto the spindle until it seats in the outer bearing cup.
- (6) Install the washer and hub nut. Tighten the hub nut, while rotating the assembly, until the hub drags then back the nut to the first slot that aligns with the cotter pin hole in the spindle.
- (7) Install the cotter pin and bend the end up over the hub nut and the spindle.
- (8) Install the cap and wheel/tire assemblies. Torque the lug nuts to 40 ft. lbs.
- (9) Remove blocks and lower work platform to the ground.

5-21. BRAKE CYLINDER (Figure 5-12).

a. Removal.

- (1) Block the wheels to prevent the work platform from rolling when the brake is removed.
- (2) Disconnect the hose assemblies and cap the opening to prevent foreign material from entering.
- (3) Remove the capscrews and lockwashers to remove cylinder from the chassis.

b. Disassembly.

NOTE

Prepare a clean work area on which to service the internal parts.

- (1) Remove the snap ring and withdraw the shaft and all attached components from the cylinder barrel.
- (2) Remove the head cap from the shaft then remove the wiper, shaft seal and seals from the head cap.
- (3) Unscrew the piston from the shaft and remove the static seal. Remove the piston seal from the piston.
- (4) Remove the spring and stop tube from the cylinder barrel.

c. Cleaning and Inspection.

- (1) Clean all metal parts in solvent and blow dry with filtered compressed air.
- (2) Check all thread parts for stripped or damaged threads.
- (3) Check the bearing surfaces inside of the head cap, outer edge surface of the piston, inside of the cylinder barrel and the shaft for signs of scoring or excessive wear.
- (4) Check the spring for cracks.
- (5) Replace any parts found unserviceable.
- (6) Discard all seals.

d. Assembly and Installation.

- (1) Install the piston seal on the piston then assemble the static seal, shaft and piston.
- (2) Position the spring and stop tube on the shaft assembly.
- (3) Lubricate the piston seal with clean hydraulic fluid, then install the shaft assembly in the cylinder barrel.
- (4) Lubricate the seals with clean hydraulic fluid and install on the head cap.
- (5) Install the shaft seal and wiper within the head cap.
- (6) Lubricate entire assembly's seals and the shaft seal and wiper with clean hydraulic fluid then install the head cap onto the shaft and into the cylinder barrel.
- (7) Secure with snap ring.
- (8) Position the brake cylinder assembly on the chassis so that the shaft will fully engages the brake disc, however the shaft must clear the brake disc once retracted. Secure with capscrews and lockwashers.
- (9) Connect the hose assemblies.
- (10) Operate the brake retract circuit and check that the shaft clears the brake disc. Check for leaks.

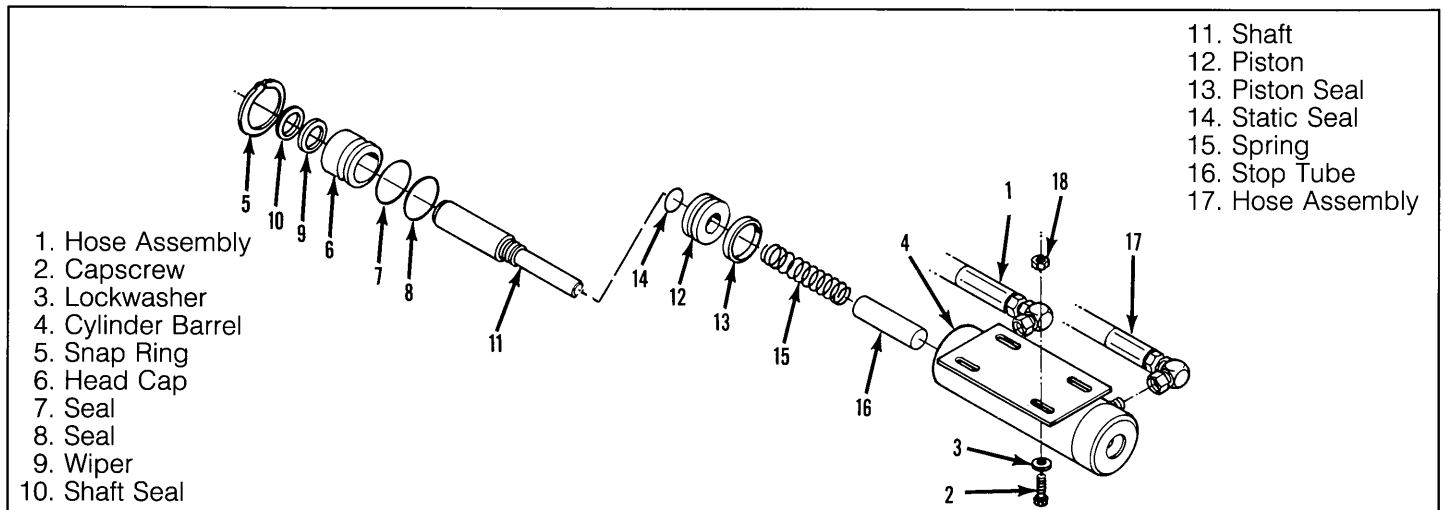

Figure 5-12. Brake Cylinder

5-22. STEERING CYLINDER (Figure 5-13).

a. Removal.

- (1) Mark and disconnect the hose assemblies from the fittings and immediately cap the openings to prevent foreign material from entering.
- (2) Remove the cotter pins and clevis pins.
- (3) Remove the locknuts and capscrews to remove the cylinder assembly.

b. Disassembly.

- (1) Remove the tie rod nuts, tie rods and the end plates.
- (2) Remove the headcaps from the barrel tube.
- (3) Withdraw the entire shaft assembly from either end of the barrel tube.
- (4) Remove the rod wiper, rod seal and static O-rings from the headcaps.
- (5) Discard all the seals.
- (6) Unscrew the No. 1 shaft from the No. 2 shaft and remove the piston.
- (7) Remove the piston seal and static O-ring from the piston.
- (8) Discard the static O-ring and piston seal.

c. Cleaning and Inspection.

- (1) Wash all the metal parts in cleaning solvent and blow dry with filtered compressed air.
- (2) Inspect all the threaded components for stripped or damaged threads.
- (3) Check the inside surface of the barrel tube for scoring or excessive wear.
- (4) Check the piston and head caps for scoring or excessive wear.
- (5) Inspect the surface of the shaft for scoring or excessive wear.
- (6) Replace all seals and O-rings.

d. Assembly and Installation.

- (1) Install a replacement piston seal and static O-ring on the piston.
- (2) Install the piston on the No. 1 shaft.
- (3) Thread the No. 2 shaft onto the No. 1 shaft and tighten securely.
- (4) Lubricate the piston seal and install the shaft assembly in the barrel tube.
- (5) Lubricate and install replacement rod seals and static O-rings on the headcaps.
- (6) Lubricate and install replacement rod wipers in the headcaps.

NOTE

Install spacers on the XL-19C and XL-24C/24CW cylinder rods only.

- (7) Install the headcaps in the barrel tube.
- (8) Install the end plates, tie rods and tie rod nuts and tighten securely.
- (9) Position the cylinder assembly on the chassis and secure with capscrews and locknuts.

- (10) Install the clevis pins and cotter pins.

- (11) Connect the hose assemblies to the fittings.

- (12) Operate the steering circuit several times throughout its entire range of travel to expel trapped air and check for leaks.

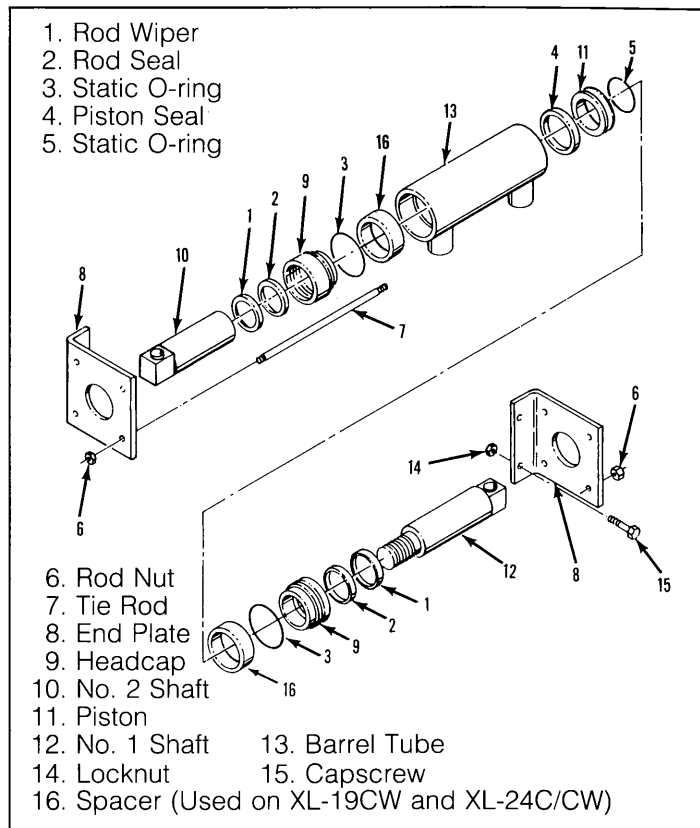

Figure 5-13. Steering Cylinder

5-23. LIFT CYLINDER REMOVAL (Figure 5-14).

a. Removal.

- (1) Block sissors linkage as per paragraph 5-5.
- (2) Remove snap rings from cylinder pin.
- (3) Remove cylinder pin and spacers from cylinder and plates.
- (4) Provide a suitable container to catch the draining hydraulic fluid, then disconnect the hydraulic hose and fitting from the base of the cylinder. Immediately plug hose to prevent foreign material from entering.
- (5) Attach a suitable hoisting device and sling to the top of the cylinder.
- (6) Lift cylinder from collar.
- (7) Move cylinder to a prepared work area.

b. Disassembly, For Welded Rod Construction (Figure 5-15).

- (1) Unscrew gland nut and withdraw the rod tube from the barrel tube.
- (2) Remove the stop ring and wear ring from the rod tube.
- (3) Remove the gland nut from the rod tube.
- (4) Remove the bleeder screw assembly.

1. Snap Ring
2. Cylinder Pin
3. Cylinder
4. Plate
5. Cylinder Collar
6. Hydraulic Fitting
7. Hydraulic Hose
8. Retaining Ring
9. Bolt
10. Bearing
11. Cylinder Collar Pin
12. Bearing
13. Grease Fitting

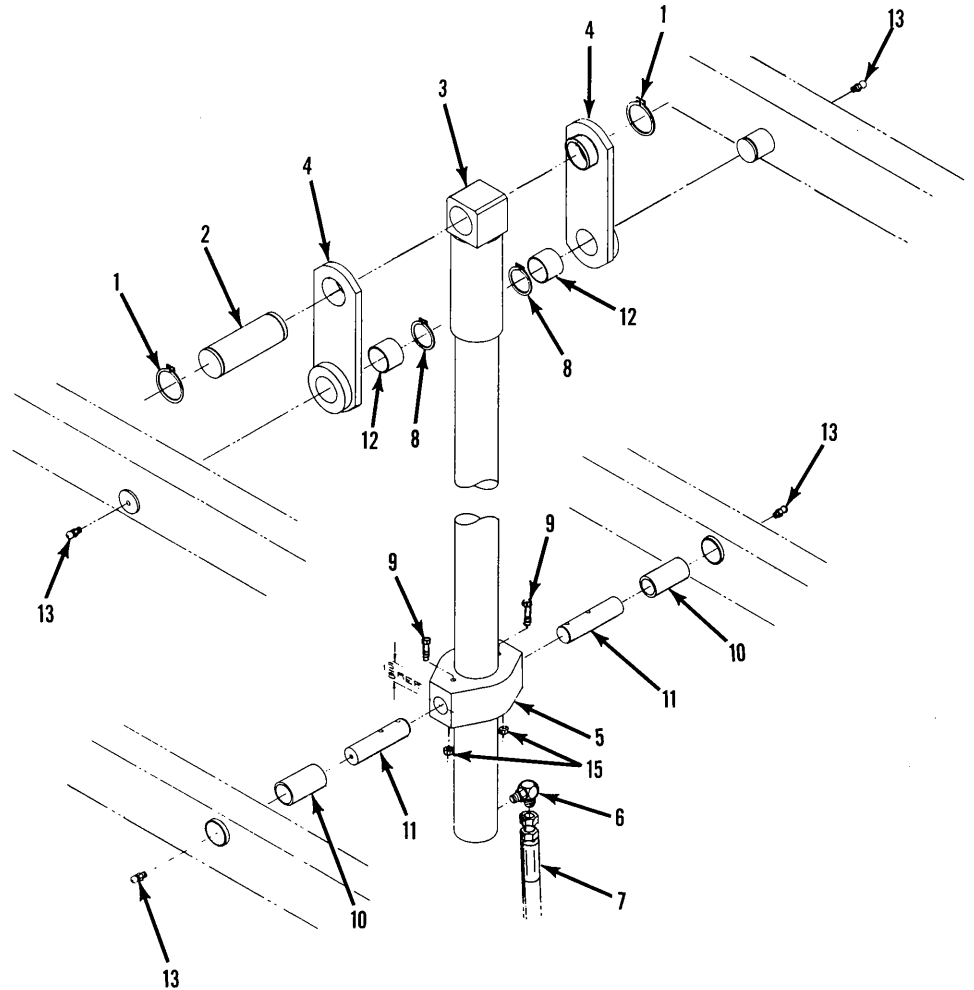

Figure 5-14. Lift Cylinder Removal

(5) Remove the O-ring, wear ring, rod seal, and rod wiper from the gland nut and discard.

(6) Remove the velocity fuse from the barrel tube.

c. **Cleaning and Inspection** (Figure 5-15).

- (1) Clean all the metal parts in cleaning solvent and blow dry with filtered compressed air.
- (2) Check the mating surfaces of the mount tube, barrel tube and rod tube for excessive wear or scoring.
- (3) Replace all parts found unserviceable.
- (4) Replace all seals and O-rings.

d. **Reassembly, For Welded Rod Construction** (Figure 5-15).

(1) Lubricate and install the rod seal, wear ring, rod wiper and O-ring in the gland nut.

NOTE

Vaseline petroleum jelly or equivalent lubricant should be used.

- (2) Place the gland nut installation ring in the grooves in the rod tube and lubricate.
- (3) Slide the gland nut onto the rod tube.

(4) Remove the gland nut installation ring and install the stop ring and wear ring in the rod tube.

NOTE

Wear ring is to be installed in groove nearest the end of rod tube.

- (5) Lubricate the rod tube and install in the barrel tube.
- (6) Thread the gland nut onto the barrel tube and tighten securely.
- (7) Install the bleeder screw assembly.
- (8) Install the velocity fuse into the barrel tube port.

e. **Installation** (Figure 5-14).

NOTE

Lubricate the cylinder pin with hydraulic fluid prior to installation.

- (1) Slice the lift cylinder into the cylinder collar.
- (2) Connect the hydraulic fitting and the hydraulic hose.
- (3) Raise the plates to align with the cylinder and install the cylinder pin.
- (4) Install the snap rings to each end of the cylinder pin.

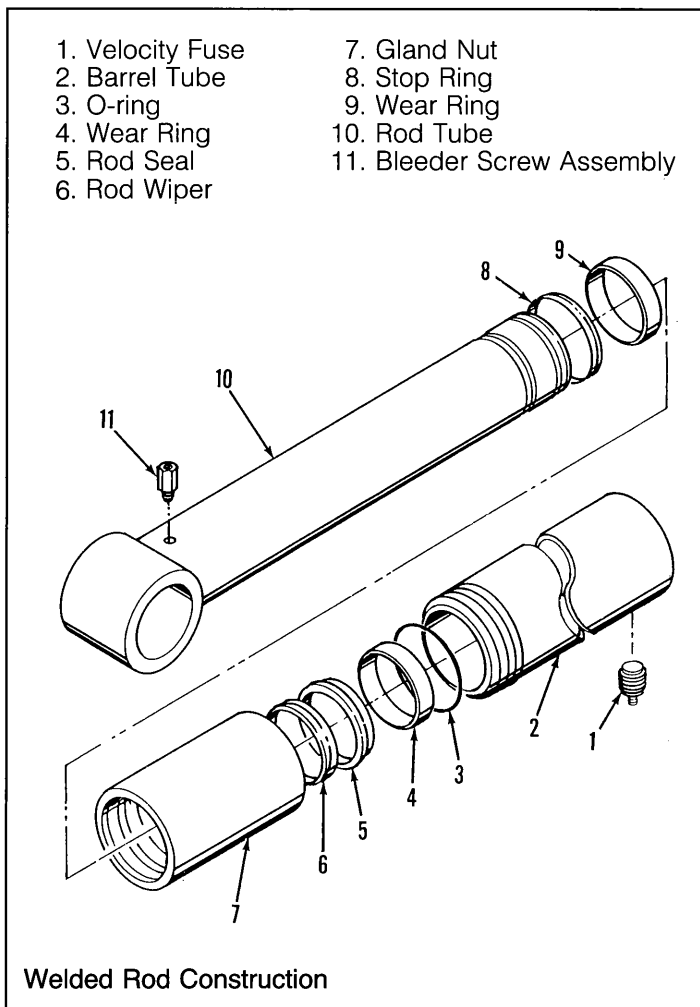

Figure 5-15. Lift Cylinder Disassembly

- (5) Operate the hydraulic lift circuit with the bleeder screw (Figure 5-15) loose to allow trapped air to escape the lift cylinder. Once hydraulic fluid flows continuously from bleed port, tighten the bleeder screw. Check for leaks.
- (6) Test with weight at the rated platform load to check system operation.

5-24. ELECTRIC MOTOR SERVICE (Figure 5-16). The permanent magnet motor differs from conventional D.C. motors in that the field winding has been replaced with ceramic magnet pole pieces. **Do not impact, drop, or squeeze the motors as this can cause damage to the ceramic pole pieces and will affect warranty considerations.** Care must be taken when the permanent magnet motor is disassembled, since the magnet pole pieces will attract ferrous metals. This fact dictates motors should be disassembled in an area free of ferrous metal chips.

a. Troubleshooting.

- (1) Read the nameplate to become familiar with the motor, especially the rated voltage.
- (2) Try to turn the shaft by hand. Keep motor leads separated while doing this. If the shaft turns freely go to item (3). If the shaft won't turn, proceed to item (2A).
- (2A) The shaft could be tight for a number of reasons. This check is to determine if the tightness is of a

temporary nature only. Obtain a power to produce the nameplate voltage. **Do Not Make A Permanent Connection.** First touch the motor leads quickly to the power supply just long enough to observe if the shaft turns. If it does turn, then hold the motor leads on the power supply for a longer time. If the motor sounds normal, go to item (3). If the motor sounds noisy, it should be taken apart as described in this bulletin.

- (3) If the motor turned freely, connect an ammeter in the circuit as shown in Figure 5-16 A. With rated voltage applied and the shaft running free, the ammeter should read less than 20% of the nameplate full load current. If the motor meets the above conditions then it can be assumed the original problem is external to the motor.

b. Disassembly.

- (1) Remove thru bolts.
- (2) Remove pulley end cover.
- (3) Pull the armature out of the assembly in one swift motion. **It is important that the pulling motion on the Armature be continuous. Do not pull part way out and release.** If this is done, the magnets will pull the armature back into the stator and cause severe damage.
- (4) Remove commutator end cover.

NOTE

Do not place the stator ring in any mechanical holding device during the disassembly or assembly operation. Permanent distortion or other damage will result.

c. Troubleshooting. Once the motor has been disassembled, go through the following check list steps to determine where the problem lies.

- (1) Bearings - Should spin smoothly and easily and have ample lubrication and be free of corrosion.
- (2) Armature - Check for grounds and shorted turns. Refinish commutator surface if pitted or excessively worn.
- (3) Brushes - Check brushes for wear and to ensure that they are free in the brush holders.

NOTE

Observe how brushes are assembled in brush holders and position of brush lead. New brushes must be installed in same manner. Brushes should be removed as follows:

- Remove brush spring clip from its mounting on brush assembly.
 - Lift brush assembly from brush holder.
 - Disconnect brush assembly lead.
 - New brush assembly to be installed by reversing above procedure.
- (4) Inspect wire harness and all connections for signs of damage due to overheating.
 - (5) Stator - Check magnets to see if they are securely mounted.

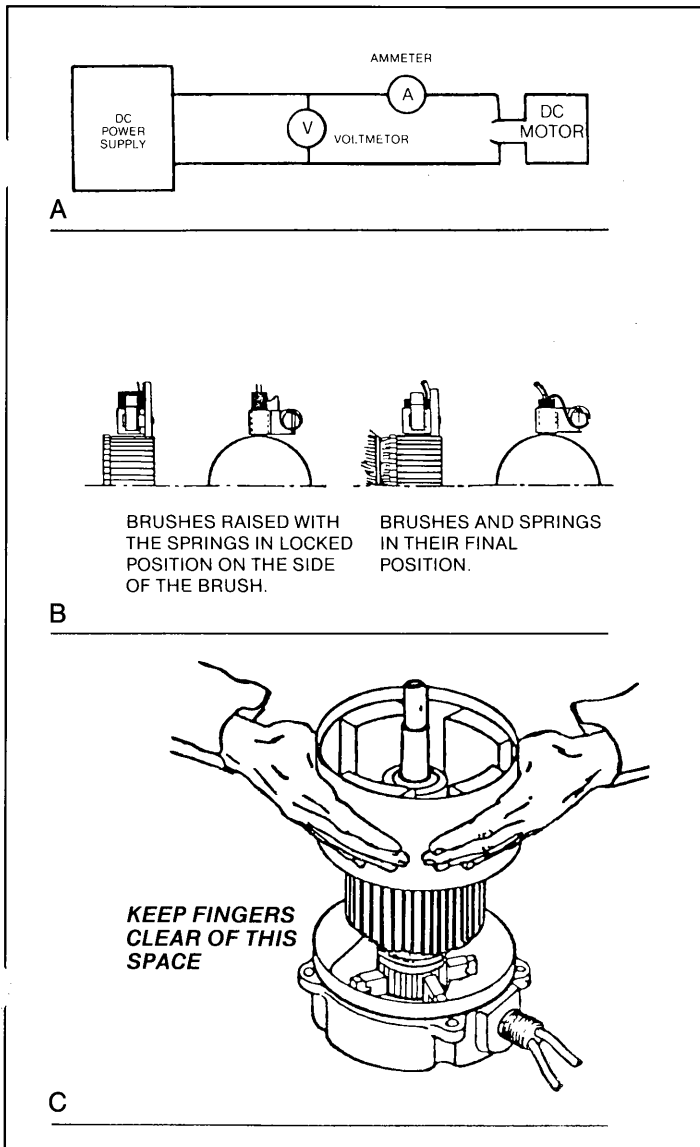

Figure 5-16. Electric Motor Service

d. Reassembly.

- (1) Install new brushes and be sure they are free in the holder. Install brush with the lead wires positioned as when received. Raise all brushes to the locked position. (See Figure 5-16 B and (3) in the Trouble Shooting segment).
- (2) Place commutator cover on a work bench with brush assembly facing upward.
- (3) Place the bearing spring into the bearing bore.
- (4) Take a complete armature assembly, including bearings, and insert commutator end bearing into the bearing bore.

NOTE

Do not re-use bearings which have been removed from armature shaft. Keep assembly in a vertical position. Use extreme care not to damage armature with bearing pullers. New bearings should be installed by pressing inner race of bearing onto proper position on armature shaft.

- (5) Set the brushes to final position as shown in Figure 5-16 B.

- (6) The next step is place the complete stator down over the vertical armature, and into position on the commutator cover.

CAUTION

Care must be exercised at this point. There is a strong magnetic attraction between the stator assembly and the armature, which tends to pull the stator assembly rapidly downward. It is important to have a firm grasp of the stator assembly and be sure fingers are free from the space between stator assembly and commutator cover (see Figure 5-16 C).

- (7) The stator assembly must be placed in a definite relationship with the commutator covers in order to obtain a neutral brush setting. There is a match-mark on both items. *These two marks must line up exactly. Rotate until they do.*
- (8) Assemble the pulley end cover in the proper relationship. Insert mounting bolts and tighten alternately to ensure a good mechanical alignment.
- (9) Spin the shaft by hand to see if it is free. Be sure motor leads (if used) are not touching together. If the leads are touching, a generator action will give the effect of friction in the motor. A no-load test can now be performed. At rated voltage, observe the no-load current. It should be less than 20% of the nameplate full load current. Anything higher indicates:
 - Brushes are not on neutral setting (check match-marks for exact alignment).
 - Faulty armature.

SECTION VI

DIAGRAMS

6-1. CONTENT. This section contains electrical diagrams, hydraulic power diagrams, and associated information for maintenance purposes.

6-2. USE. The diagrams are to be used in conjunction with Table 5-2 **TROUBLESHOOTING**. They allow understanding of the make-up and functions of the systems for checking, tracing, and fault-finding during trouble analysis.

6-3. INDEX OF DIAGRAMS. The diagrams appear in the following order:

Figure 6-1. Electrical Diagram.

Figure 6-2. Hydraulic Diagram.

6-4. DIAGRAM LEGENDS. The components that comprise the electrical and hydraulic systems are given a reference designation and are explained as to location and function in the following tables:

Table 6-1. Electrical Diagram Legend.

Table 6-2. Hydraulic Diagram Legend.

Table 6-1. Electrical Diagram Legend.

REFERENCE DESIGNATION	NAME	FUNCTION	LOCATION
B	Motor, Electric	Provides power to Drive Hydraulic Pump.	Front Center of Module.
BT	Batteries 6 volts	To store energy rear of Module platform.	Two per side
CR1	Motor Relay	Connects Batteries to Motor.	Right Front of Module.
D1	Diode	Provides power to Motor Relays when Steer Switch is activated RIGHT .	Between T1 and T2 on Fanning Strip.
D2	Diode	Provides power to Motor Relays when Steer Switch is activated LEFT .	Between T3 and T2 on Fanning Strip.
D3	Diode	Provides power to Motor Relay when Lift and Drive Switches are activated.	Between T2 and T5 on Fanning Strip.
D4	Diode	Provides power to Steering Bypass and Speed Range Switch when Drive Switch is activated FORWARD .	Between T4 and T5 on Fanning Strip.
D5	Diode	Provides power to Steering Bypass and Speed Range Switch when Drive Switch is activated REVERSE .	Between T6 and T5 on Fanning Strip.
D6	Diode	Provides power to Steering Bypass and Speed Range Switch when Lift Switch is activated UP .	Between T7 and T5 on Fanning Strip.

Table 6-1. Electrical Diagram Legend - Continued.

REFERENCE DESIGNATION	NAME	FUNCTION	LOCATION
F1	Fuse, 15 AMP	Provides over-load protection for the Control Circuit.	At rear of right Module.
HN	Alarm, Down	Provides warning sound when deck is lowering.	Left front of Module.
L1	Solenoid (coil)	Shifts Steer Valve to RIGHT turn position.	Right end of Spool Valve mounted on left top of Manifold Block.
L2	Solenoid (coil)	Shifts Steer Valve to LEFT turn position.	Left end of Spool Valve mounted on left top of Manifold Block.
L3	Solenoid (coil)	Shifts Drive Valve to FORWARD position.	Left end of Spool Valve mounted on right top of Manifold Block.
L4	Solenoid (coil)	Closes Steering Bypass Valve.	Top left of front of Manifold Block.
L5	Solenoid (coil)	Shifts Drive Valve to REVERSE position.	Right end of Spool Valve mounted on right top of Valve Manifold.
L6	Solenoid (coil)	Opens Lift Valve.	Top right Coil on front of Manifold Block.
L7	Solenoid (coil)	Closes Lift Bypass Valve.	Bottom Center Coil on front of Manifold Block.
L8	Solenoid (coil)	Opens Down Valve.	Central bottom of Manifold Block.
L9	Solenoid	Closes High Speed Valve.	Top center Coil of front of Manifold Block.

Table 6-1. Electrical Diagram Legend - Continued.

REFERENCE DESIGNATION	NAME	FUNCTION	LOCATION
S1	Switch, Guarded Emergency Stop.	Control Circuit shut off.	On Control Box right front.
S2	Switch, Key Mode	Supplies power to Lift, Drive and Steer switch.	On Control Box side.
S3	Switch, Lift	Supplies power to Lift or Lower Valve Solenoids.	On Control Box left center.
S4	Switch, Steer	Supplies power to Steer Valve Solenoids.	On Control Box left rear.

REFERENCE DESIGNATION	NAME	FUNCTION	LOCATION
S5	Switch, Drive	Supplies power to Drive Valve right rear. Solenoids.	On Control Box
S6	Switch, Speed Range	Supplies power to High Speed Valve Solenoids.	On Control Box left front.
S7	Switch, Chassis Lift	Supplies power to Lift or Lower Valve Solenoids.	Left front of Module.
S8	Switch, Platform Height Limit	Opens Lift Valve Solenoid Circuit when Deck is fully elevated.	Near left side Roller Track at center of work platform.

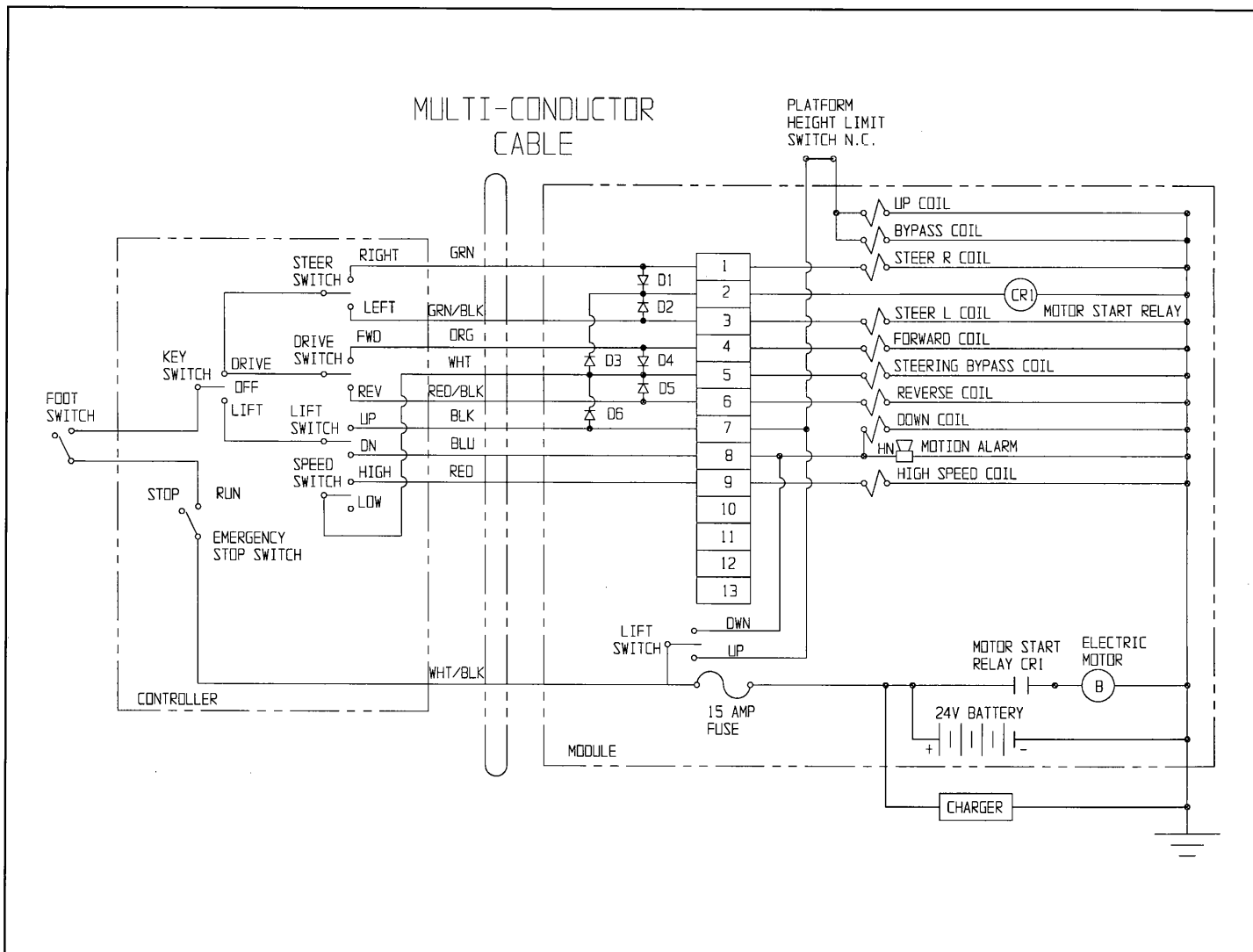

Figure 6-1. Electrical Diagram

Table 6-2. Hydraulic Diagram Legend

REFERENCE DESIGNATION	NAME	FUNCTION	LOCATION
ASSY1	Duplex Pump	Supplies hydraulic oil flow for Lift, Drive, and Steer.	On Electric Motor at left front of Module.
CV1	Check Valve	Prevents oil of both sections of Pump from combining.	Bottom front of left side of Manifold Block
CV2	Check Valve	Prevents oil of both sides of Pump from combining.	Top left of front of Manifold Block.
CV3	Check Valve	Prevents oil from flowing back through Lift Valve.	Top center of back of Manifold Block.
CV4	Check Valve	With platform down prevents oil from flowing to Tank in HIGH speed.	Back center of bottom of Manifold Block.
CV5	Check Valve	Allows Steering Valve to function at a higher pressure than drive.	Outer front of left side of Manifold Block.
CYL1	Cylinder, Steering	Provides force to turn front Wheels.	Center front of Chassis.
CYL2	Cylinder, Brake	Stops Machine from moving while parked.	Left rear side of Chassis.
CYL3	Cylinder, Lift	Provides force to lift Platform.	Inside the inner Scissors Frame Weldments.
FL1	Filter	Filters oil returning to Tank.	Right front of Module.
MOT1	Drive Motor	Provides tractive effort for work platform.	On left front Steering Spindle.
MOT2	Drive Motor (Optional)	Provides tractive effort for work platform.	On right front Steering Spindle.
ORF1	Orifice, Brake	Delays the engagement of the Brake Cylinder Shaft.	Bottom right of back of Manifold Block. surface.
ORF2	Orifice, Lift	Controls the platform rate of descent.	Center of back of Manifold Block.

Table 6-2. Hydraulic Diagram Legend - Continued

REFERENCE DESIGNATION	NAME	FUNCTION	LOCATION
SV1	Valve, Shuttle	Provides oil to Brake Cylinder when either Drive FORWARD or REVERSE are actuated.	Bottom center of right side of Manifold Block.
V1	Valve, Steer	Provides directional control for Steering Cylinder.	Left top of Manifold Block.
V2	Valve, Counterbalance FORWARD	Prevents machine from running away on slopes and cushions stops.	Right top of front of Manifold Block.
V3	Valve, Counterbalance REVERSE	Prevents machine from running away on slopes and cushions stops.	Right bottom of front of Manifold Block.
V4	Valve, Drive	Provides directional control of oil for drive functions.	Right top of Manifold Block.
V5	Valve, Velocity Fuse	Locks Lift Cylinders if lines break.	Inside Each Lift Cylinder port.
V6	Valve, Steering Bypass	Prevents oil from bypassing while driving and lifting.	Top left of Manifold Block.
V7	Valve, Lift	Provides oil flow to Lift Cylinders.	Top right Coil on front of Manifold Block.
V8	Valve, High Speed	Prevents oil from bypassing while driving and lifting.	Top center Coil on front of Manifold Block.
V9	Valve, Lift Bypass	Prevents oil from bypassing while lifting.	Bottom center Coil on front of Manifold Block.
V10	Valve, Emergency Lowering	Provides manual means of allowing oil to flow from Lift Cylinders to Tank.	Bottom center of front of Manifold Block.
V11	Valve, Down	Allows oil to flow out of Lift Cylinders to Tank.	Center of bottom of Manifold Block.
RV1	Valve, Main Relief	Provides over pressure protection to Pump.	Left front of Manifold Block.

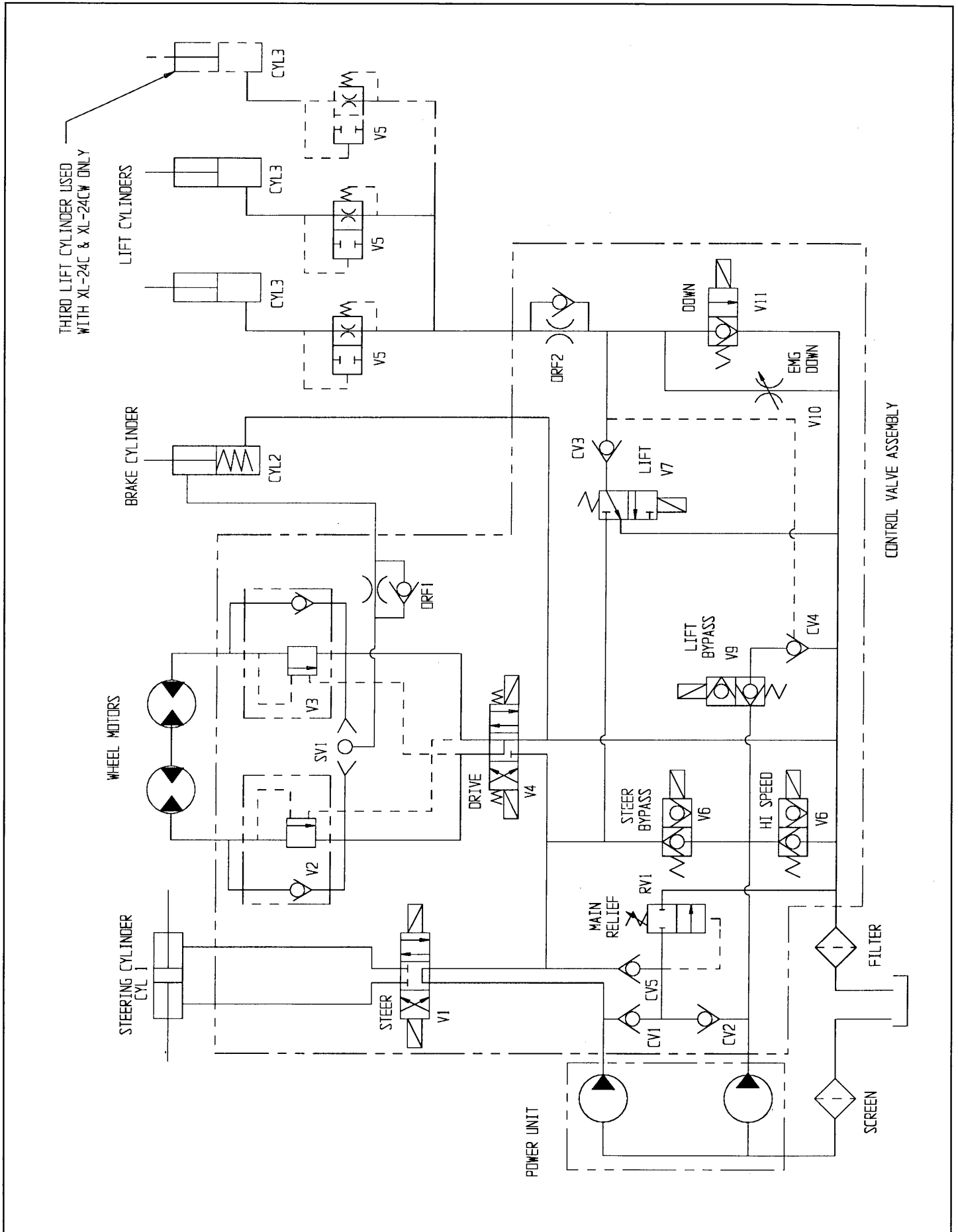

Figure 6-2. Hydraulic Diagram

SECTION VII

ILLUSTRATED PARTS BREAKDOWN

7-1. INTRODUCTION.

This section lists and illustrates the replaceable assemblies and parts of the XL-C SERIES Work Platform, as manufactured by UPRIGHT INC., Selma, California, 93662.

Each assembly is followed by its components parts indented to show their relationship to the assembly.

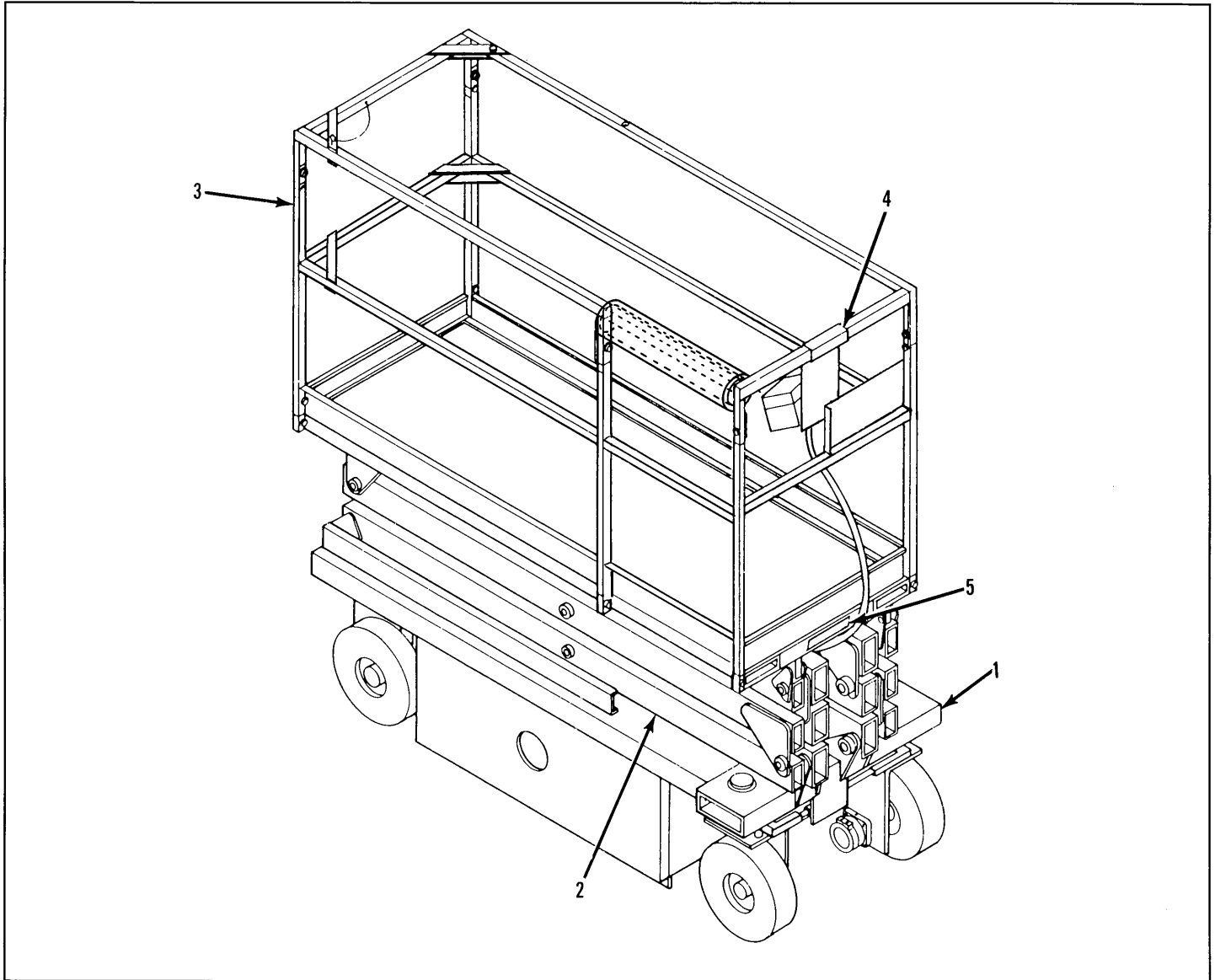

Figure 7-1. Work Platform, XL-19C

ITEM	PART	DESCRIPTION	QTY.
7-1	63500-000-00	WORK PLATFORM, XL-19C	1
-1	No Number	. CHASSIS ASSEMBLY. (See Figure 7-3)	1
-2	No Number	. SCISSORS ASSEMBLY (See Figures 7-16)	1
-3	No Number	. FOLD DOWN GUARDRAIL INSTAL- LATION (See Fig. 7-19)	1
-4	63404-000-00	. CONTROLLER ASSEMBLY (See Figure 7-21)	1
-5	61833-002-00	. DECAL KIT INSTALLATION (See Section II, Page 9)	1

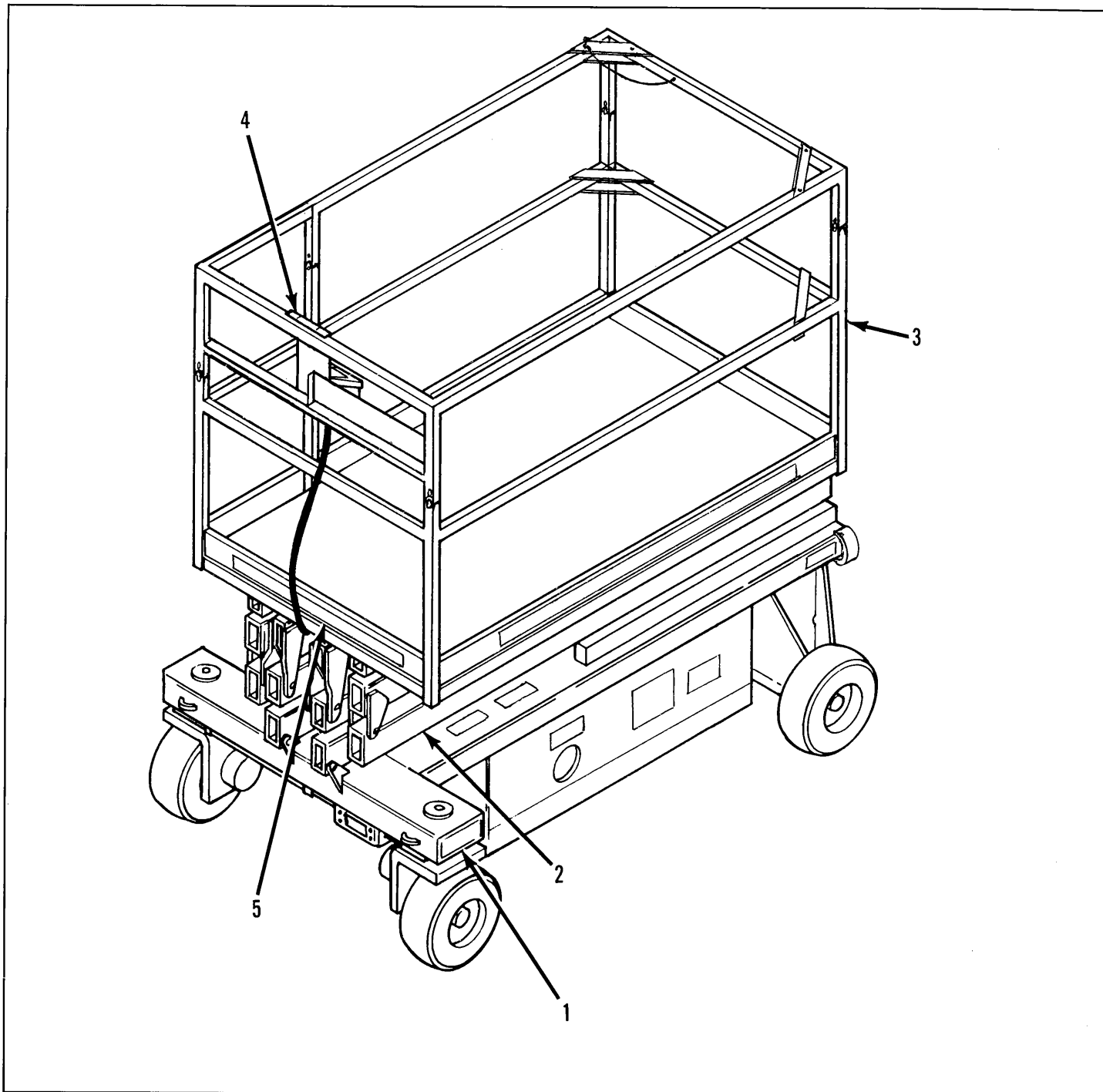

Figure 7-2. Work Platform, XL-19CW, XL-24C and XL-24CW

ITEM	PART	DESCRIPTION	QTY.
7-2	63600-000-00	WORK PLATFORM, XL-19CW	1
	63700-000-00	WORK PLATFORM, XL-24C	1
	63750-000-00	WORK PLATFORM, XL-24CW	1
-1	No Number	. CHASSIS ASSEMBLY. (See Figure 7-4)	1
-2	No Number	. SCISSORS ASSEMBLY (See Figures 7-16/17)	1

ITEM	PART	DESCRIPTION	QTY.
-3	No Number	. FOLD DOWN GUARDRAIL INSTALLATION (See Fig. 7-20)	1
-4	63404-000-00	. CONTROLLER ASSEMBLY (See Figure 7-21)	1
-5	61855-002-00	. DECAL KIT INSTALLATION XL-19CW (See Sec.II, page 10)	1
	61953-002-00	XL-24C (See Sec.II, page 10)	1
	61955-003-00	XL-24CW (See Sec.II, page 10)	1

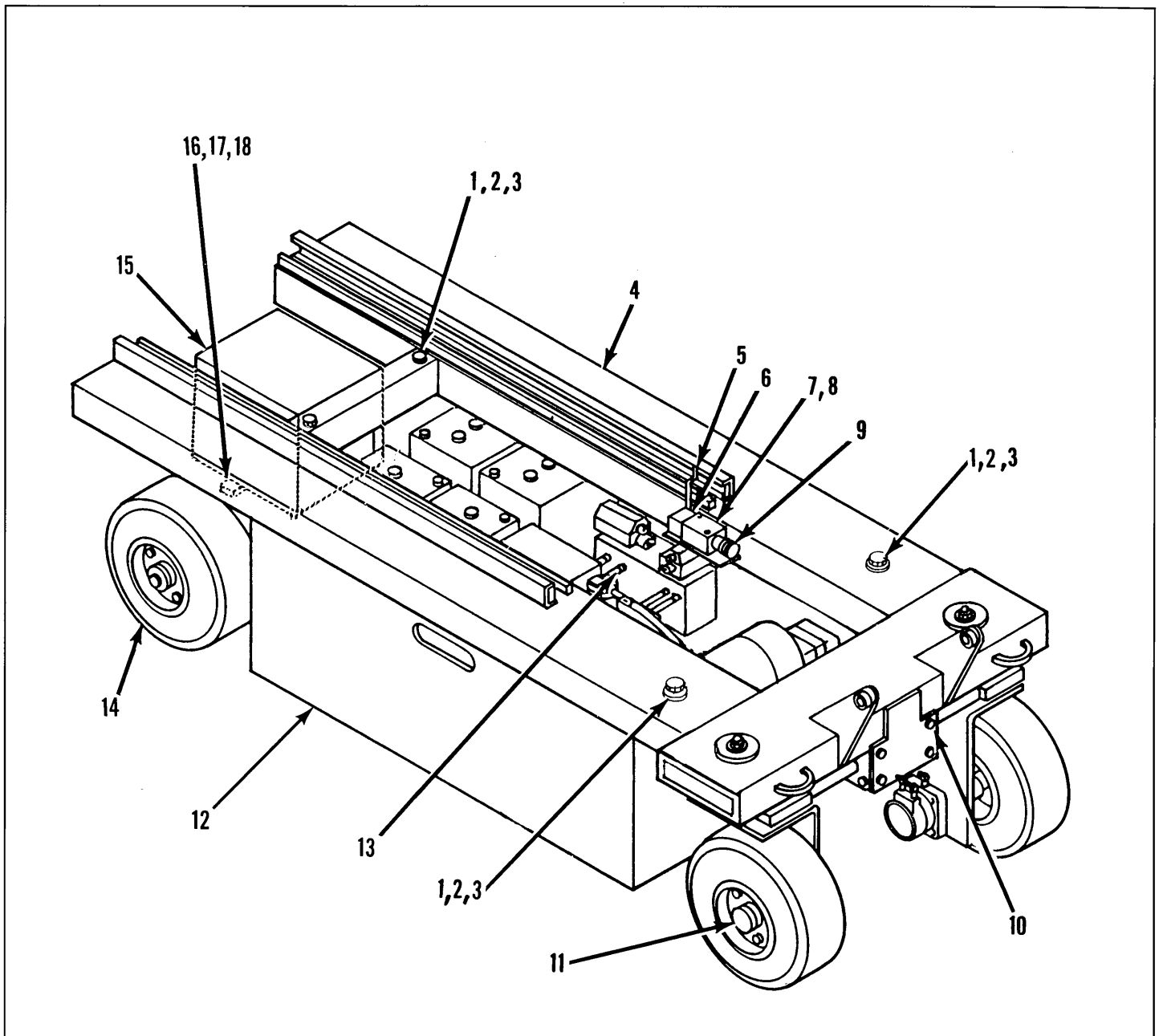

Figure 7-3 Chassis Assembly, XL-19C

ITEM	PART	DESCRIPTION	QTY.
7-3	No Number	CHASSIS ASSEMBLY, XL-19C	REF
-1	11254-032-00	. SCREW, HHC 3/8-16 UNC GR5 x 4	4
-2	1124-006-00	. WASHER, Flat 3/8 Dia.	8
-3	11248-006-00	. LOCKNUT, HEX 3/8-16 UNC	8
-4	61715-000-00	. FRAME WELDMENT	1
-5	61753-000-00	. WAND, Platform Height	1
-6	No Number	. SWITCH ASSEMBLY, limit	1
	15793-001-00	.. BODY, Switch	1
	15793-002-00	.. HEAD, Switch	1
	15793-004-00	... SWITCH	1
	15793-003-00	.. LEVER	1
-7	11709-016-00	. SCREW, RD HD MACH 10-24 UNC x 2	2
-8	11248-003-00	. LOCKNUT, HEX 10-24 UNC	2
-9	29925-000-00	. CONNECTOR	1

ITEM	PART No.	DESCRIPTION	QTY.
-10	No Number	. FRONT STEERING ASSEMBLY (See Figure 7-5)	1
-11	No Number	. DRIVE MOTOR/WHEEL ASSEMBLY (See Figure 7-7)	1
-12	No Number	. MODULE ASSEMBLY (See Figure 7-8)	1
-13	61805-000-00	. HOSE KIT/INSTALLATION (See Figure 7-14)	1
-14	No Number	. REAR WHEEL AND HUB ASSEMBLY (See Figure 7-12)	1
-15	63944-001-00	. CHARGE, Battery 60 HZ	1
-16	11252-008-00	. SCREW, HHC 1/4-20 UNC x 1	2
-17	11248-004-00	. LOCKNUT, HEX 1/4-20 UNC	2
-18	11240-004-00	. WASHER, 1/4 Dia. STD Flat	2

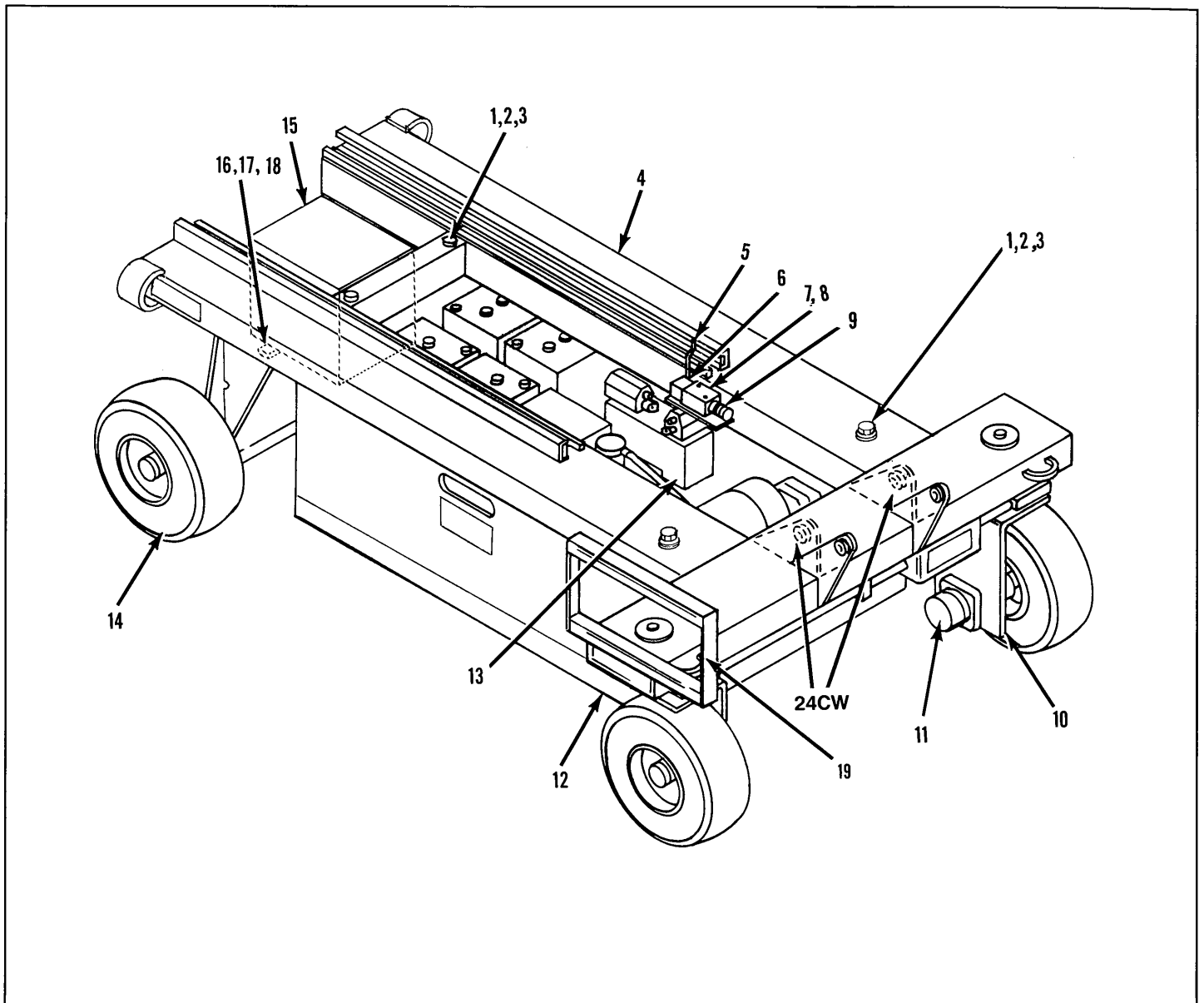

Figure 7-4 Chassis Assembly, XL-19CW, XL-24C and XL-24CW

ITEM	PART	DESCRIPTION	QTY.
7-4	No Number	CHASSIS ASSEMBLY, XL-19CW XL-24C and XL-24CW	REF
-1	11254-032-00	. SCREW, HHC 3/8-16 UNC GR5 x 4	4
-2	1124-006-00	. WASHER, Flat 3/8 Dia.	8
-3	11248-006-00	. LOCKNUT, HEX 3/8-16 UNC	8
-4	61857-000-00	. FRAME WELDMENT, XL-19CW & XL-24C	1
	63753-000-00	. FRAME WELDMENT, XL-24CW	1
-5	61753-000-00	. WAND, Platform Height	1
-6	No Number	. SWITCH ASSEMBLY, limit	1
	15793-001-00	.. BODY, Switch	1
	15793-002-00	.. HEAD, Switch	1
	15793-004-00	... SWITCH	1
	15793-003-00	.. LEVER	1
-7	11709-016-00	. SCREW, RD HD MACH 10-24 UNC x 2	2
-8	11248-003-00	. LOCKNUT, HEX 10-24 UNC	2
-9	29925-000-00	. CONNECTOR	1

ITEM	PART No.	DESCRIPTION	QTY.
-10	No Number	. FRONT STEERING ASSEMBLY (See Figure 7-6)	1
-11	No Number	. DRIVE MOTOR/WHEEL ASSEMBLY (See Figure 7-7)	1
-12	No Number	. MODULE ASSEMBLY (See Figure 7-8)	1
-13	61856-000-00	. HOSE KIT/INSTALLATION XL-19CW (See Figure 7-15)	1
	61961-000-00	. HOSE KIT/INSTALLATION XL-24C	1
	63767-000-00	. HOSE KIT/INSTALLATION XL-24CW	1
-14	No Number	. REAR WHEEL AND HUB ASSEMBLY (See Figure 7-13)	1
-15	63944-001-00	. CHARGE, Battery 60 HZ	1
-16	11252-008-00	. SCREW, HHC 1/4-20 UNC x 1	2
-17	11248-004-00	. LOCKNUT, HEX 1/4-20 UNC	2
-18	11240-004-00	. WASHER, 1/4 Dia. STD Flat	2
-19	61889-000-00	. LADDER WELDMENT XL-19CW/24C	1
	63752-000-00	. LADDER WELDMENT XL-24CW	1

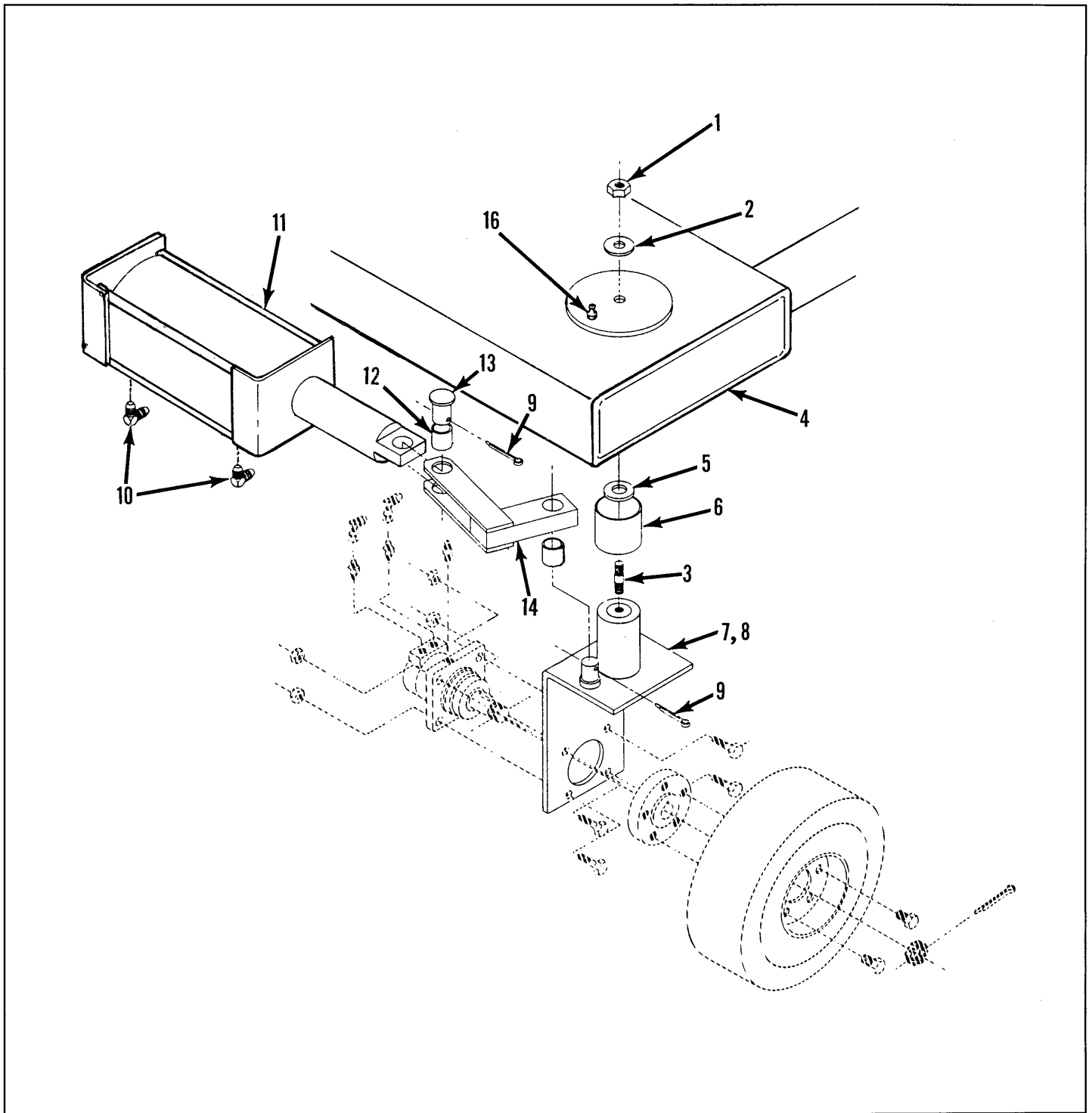

Figure 7-5. Front Steering Assembly, XL-19C

ITEM	PART	DESCRIPTION	QTY.
7-5	No Number	FRONT STEERING ASSEMBLY, XL-19C	REF
-1	11248-006-00	. LOCKNUT, HEX 3/8-16 UNC	2
-2	11240-006-00	. WASHER, Flat 3/8 Dia.	2
-3	15795-001-00	. STUD	2
-4	61715-000-00	. FRAME WELDMENT (See Figure 7-3)	REF
-5	11782-008-00	. BEARING, Thrust	2
-6	27931-032-00	. BEARING	2
-7	61712-000-00	. YOKE, R.H. (Not Shown)	1
-8	61713-000-00	. YOKE, L.H.	1

ITEM	PART	DESCRIPTION	QTY.
-9	11753-012-00	. PIN, Cotter	4
-10	11940-006-00	. FITTING, Elbow	2
-11	12802-000-00	. CYLINDER, Steering	1
	12802-008-00	. . END PLATE SET	1
	12802-014-00	. . SEAL KIT	1
-12	27931-029-00	. BEARING	4
-13	60741-000-00	. PIN	2
-14	61731-000-00	. STEERING LINK WELDMENT	2
-15	11752-016-00	. PIN, Cotter (Not Shown)	1
-16	11790-003-00	. FITTING, Grease	2

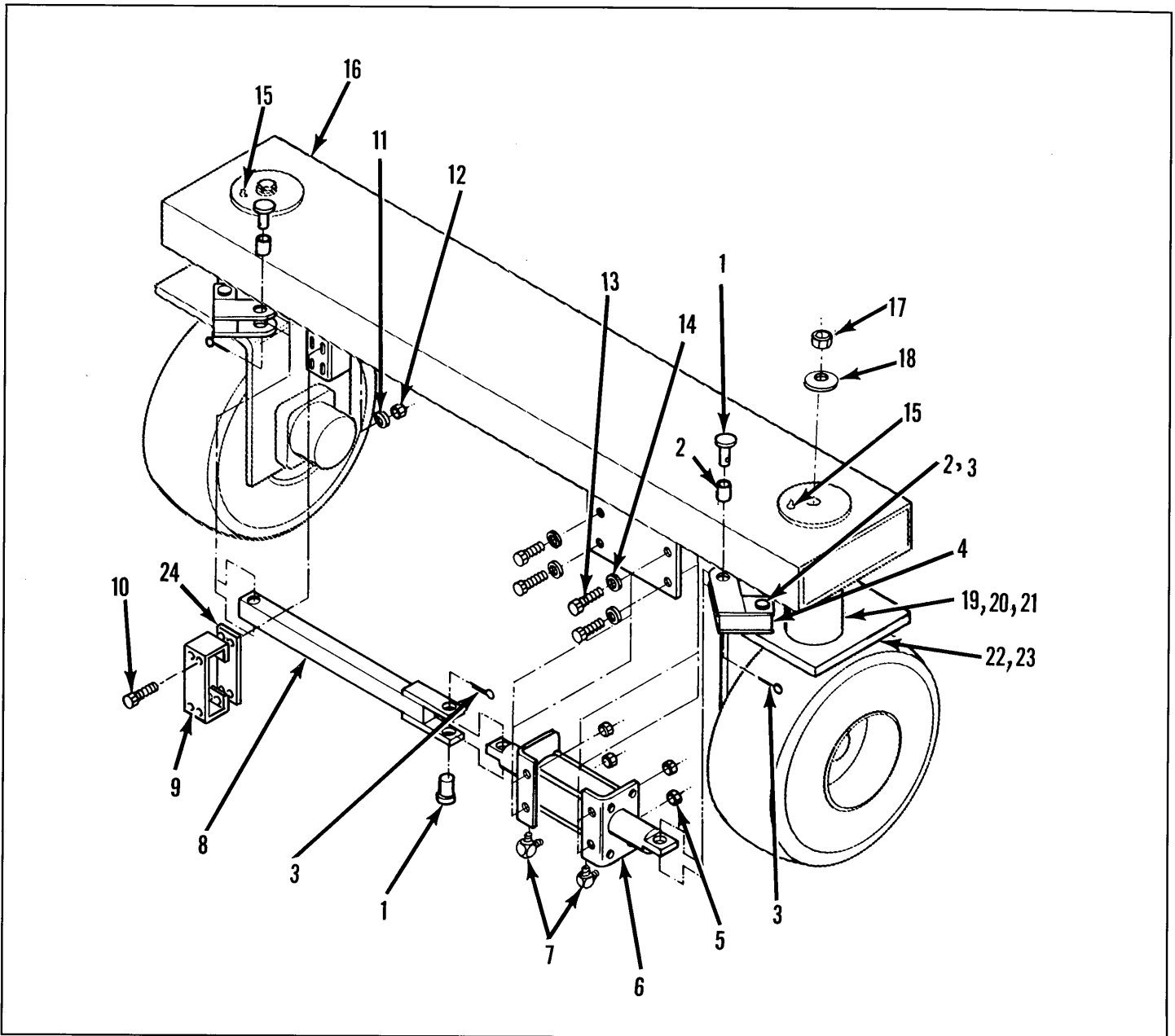

Figure 7-6. Front Steering Assembly, XL-19CW, XL-24C and XL-24CW

ITEM	PART	DESCRIPTION	QTY.
7-6	No Number	FRONT STEERING ASSEMBLY, XL-19CW, XL-24C & XL-24CW	REF
-1	60741-000-00	. PIN	3
-2	27931-029-00	. BEARING	5
-3	11753-012-00	. PIN, Cotter 1/8 x 1-1/2	7
-4	61731-000-00	. STEERING LINK	2
-5	11248-006-00	. NUT, 3/8-16 UNC ESNA	4
-6	61859-000-00	. CYLINDER, Steering	1
	12802-014-00	. SEAL KIT	1
-7	11940-006-00	. FITTING	2
-8	61860-000-00	. STEERING LINK WELDMENT XL-19CW & XL-24C	1
	63765-000-00	. STEERING LINK WELDMENT XL-24CW	1
-9	63353-000-00	. STEERING ARM GUIDE	1
-10	11252-022-00	. SCREW, HHC 1/4-20 UNC x 2-3/4	4

ITEM	PART No.	DESCRIPTION	QTY.
-11	11240-004-00	. WASHER, 1/4	4
-12	11248-004-00	. NUT, 1/4-20 UNC ESNA	4
-13	11254-012-00	. SCREW, HHC 3/8-16 UNC x 1-1/2	4
-14	11240-006-00	. WASHER, 3/8	4
-15	11790-003-00	. FITTING, Grease	2
-16	61857-000-00	. FRAME WELDMENT (See Figure 7-4) XL-19CW & XL-24C	REF
	63753-000-00	. FRAME WELDMENT XL-24CW	REF
-17	11248-006-00	. LOCKNUT, HEX 3/8-16 UNC	2
-18	11240-006-00	. WASHER, Flat 3/8 Dia.	2
-19	11782-008-00	. BEARING, Thrust	2
-20	27931-032-00	. BEARING	2
-21	15795-001-00	. STUD	2
-22	61712-000-00	. YOKE, R.H. (Not Shown)	1
-23	61713-000-00	. YOKE, L.H.	1
-24	63354-000-00	. WEAR PLATE	2

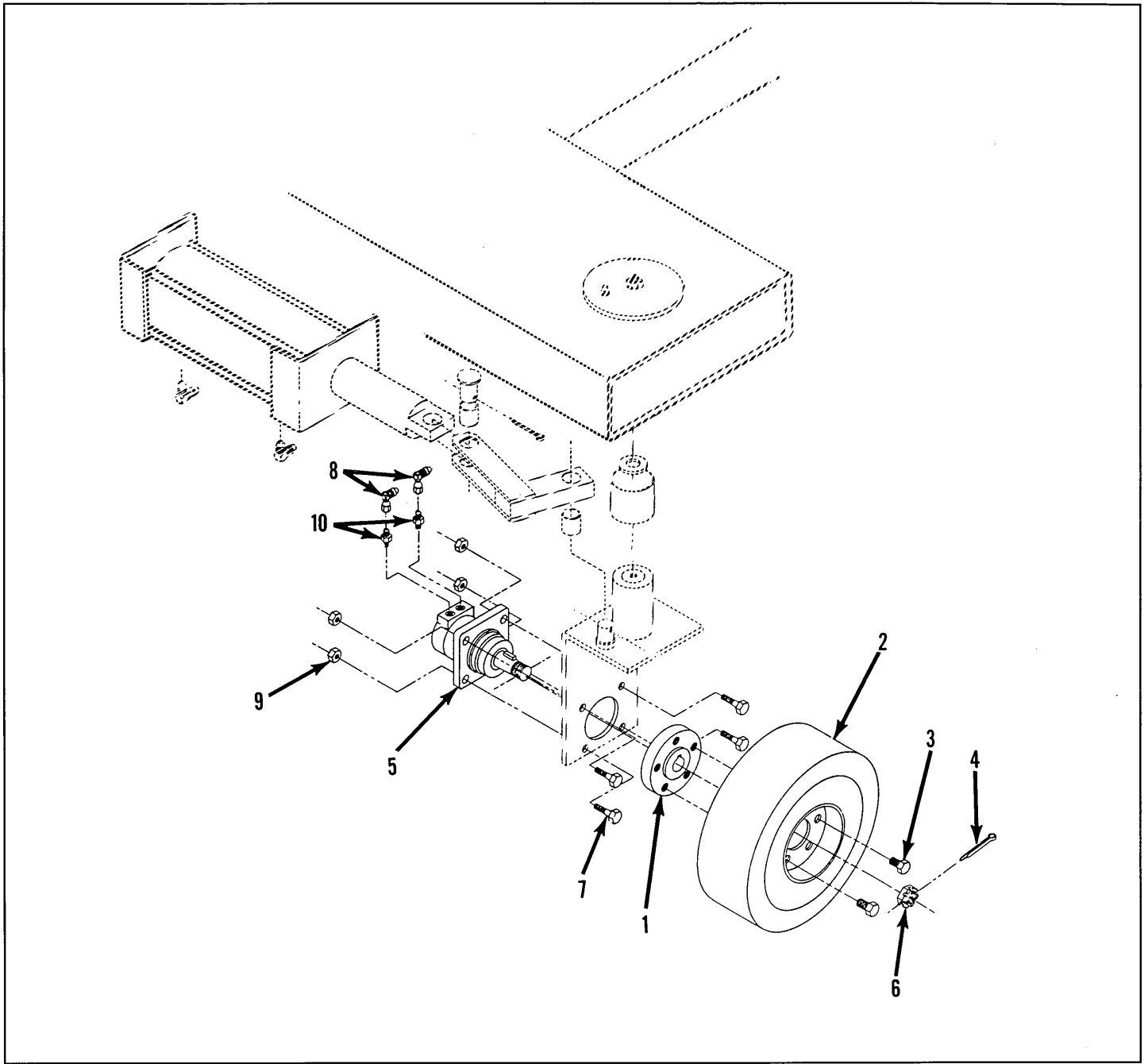

Figure 7-7. Drive Motor/Wheel Assembly, XL-C Series

ITEM	PART	DESCRIPTION	QTY.
7-7	No Number	DRIVE MOTOR/WHEEL ASSEMBLY XL-C Series	REF
-1	61840-000-00	. HUB	1
-2	61826-000-00	. WHEEL ASSEMBLY	2
-3	14122-001-00	. BOLT, Wheel	10
-4	11753-012-00	. PIN, Cotter	2
-5	61817-001-00	. MOTOR, Drive	2
	61817-010-00	. . SEAL KIT	1
-6	12795-002-00	. NUT, Castle 1-14 UNF	1
-7	11256-024-00	. SCREW, HHC 1/2-13 UNC x3	8
-8	11932-003-00	. FITTING, Elbow	2

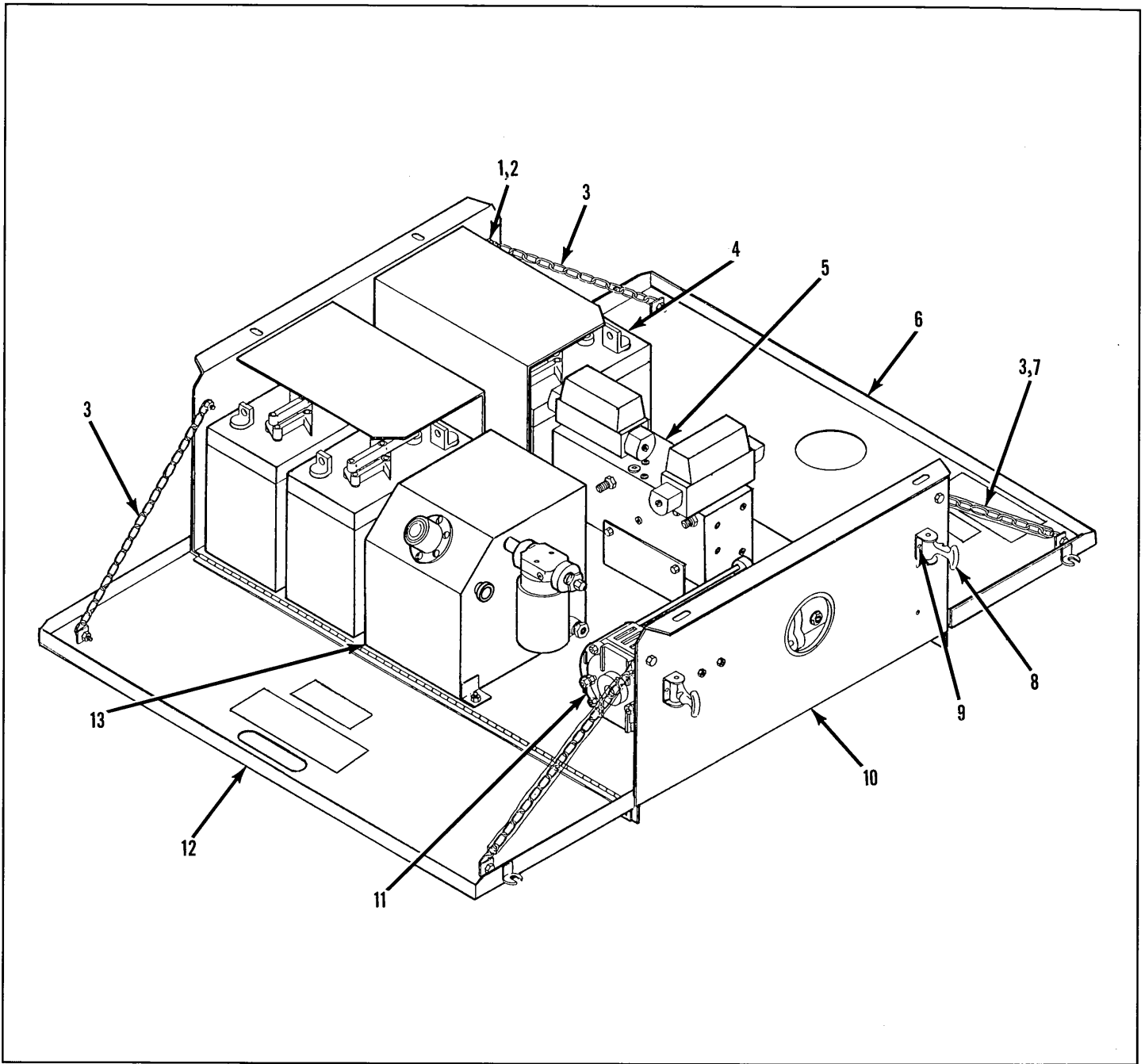

Figure 7-8. Module Assembly, XL-C Series

ITEM	PART	DESCRIPTION	QTY.
7-8	No Number	MODULE ASSEMBLY, XL-C Series	REF
-1	11252-006-00	. SCREW, HHC 1/4-20 UNC GR5 x 3/4	8
-2	11248-004-00	. LOCKNUT, HEX 1/4-20 UNC GR5 x 3/4	8
-3	15901-099-00	. CHAIN	4
-4	15796-000-00	. BATTERY, 6V 220 Amp.	4
-5	61847-000-00	. HYDRAULIC MANIFOLD XL-19C & XL-19CW (See Fig. 7-10)	1
	63233-000-00	. HYDRAULIC MANIFOLD XL-24C & XL-24CW (See Fig. 7-10)	1
-6	61824-000-00	. COVER WELDMENT, L.H.	1

ITEM	PART No.	DESCRIPTION	QTY.
-7	14495-099-00	. TUBE	2
-8	08783-002-00	. LATCH	4
-9	26553-002-00	. RIVET, Pop 3/16 Dia. .126-.250 Grip	8
-10	63504-000-00	. MODULE WELDMENT	1
-11	No Number	. PUMP/MOTOR AND ELECTRICAL COMPONENTS INSTALLATION (See Figure 7-9)	1
-12	60802-000-00	. COVER WELDMENT, R.H.	1
-13	No Number	. HYDRAULIC TANK INSTALLATION (See Figure 7-11)	1

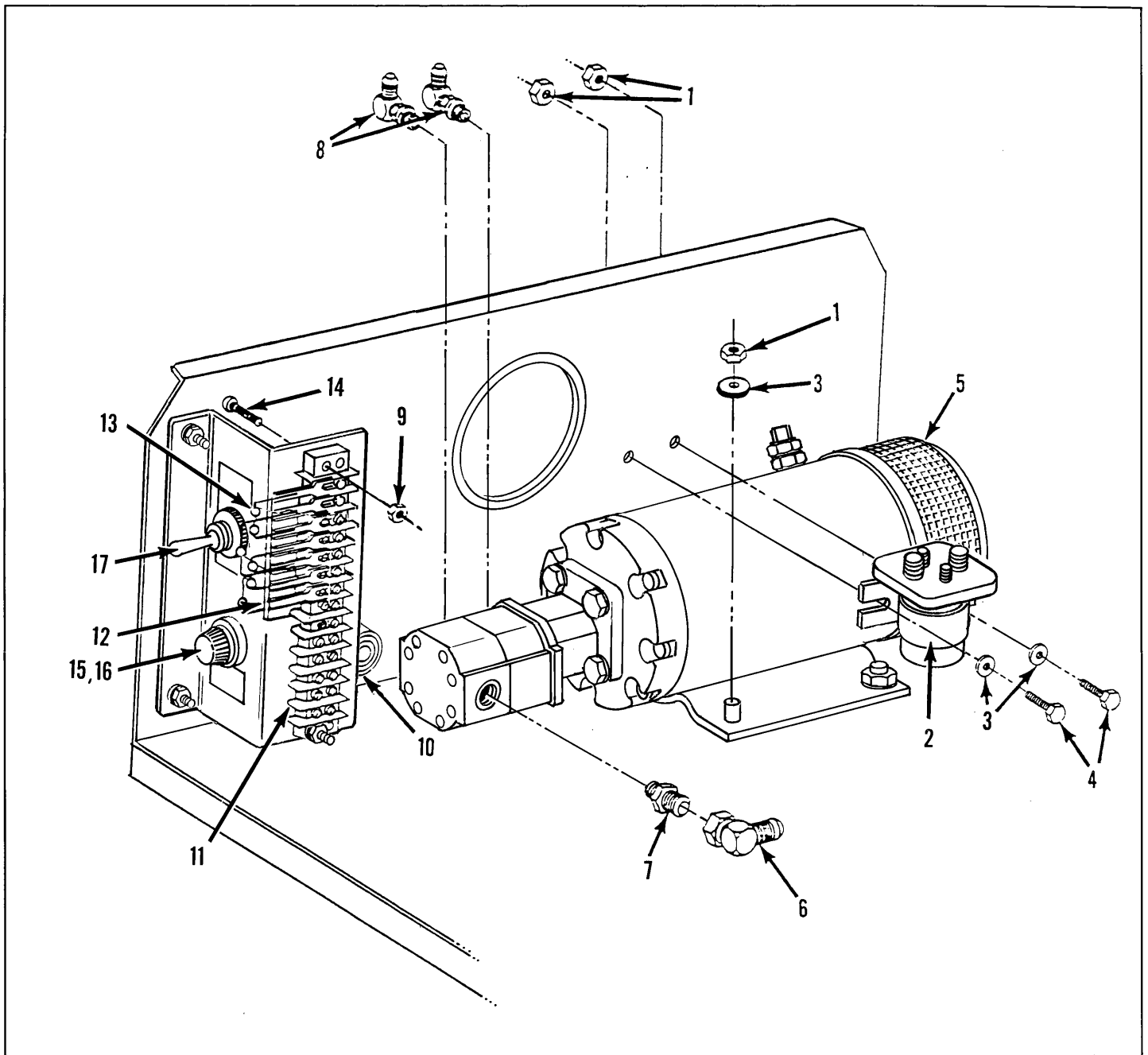

Figure 7-9. Pump/Motor and Electrical Components Installation, XL-C Series

ITEM	PART	DESCRIPTION	QTY.
7-9	No Number	PUMP/MOTOR AND ELECTRICAL COMPONENT INSTALLATION XL-C SERIES	REF
-1	11248-004-00	. LOCKNUT, HEX 1/4-20 UNC	8
-2	10122-000-00	. SOLENOID, 24 V	1
-3	11240-004-00	. WASHER, Flat	6
-4	11252-006-00	. SCREW, HHC 1/4-20 UNC GR5 x 3/4	4
-5	15797-000-00	. PUMP/MOTOR ASSEMBLY	1
	15797-001-00	.. PUMP	1
	15797-003-00	... SEAL KIT	1
	15797-002-00	.. COUPLING	1
	15797-004-00	.. MOTOR, Electric	1
	15797-005-00	... BRUSHES SET, MTE	1
	10145-001-00	... BRUSHES, Ohio	4

ITEM	PART No.	DESCRIPTION	QTY.
-6	11937-007-00	. FITTING, Elbow	1
-7	11941-012-00	. FITTING, Straight	1
-8	11934-000-00	. FITTING, Elbow	2
-9	11248-047-00	. LOCKNUT, HEX 6-32 UNC	2
-10	10189-000-00	. BUZZER	1
-11	29928-004-00	. BLOCK, Terminal	1
-12	61806-000-00	. STRIP, Fanning	1
-13	29825-002-00	.. DIODE	7
-14	11715-006-00	. SCREW, RD HD MACH 6-32 UNC x 3/4	2
-15	29701-000-00	. HOLDER, Fuse	1
-16	29704-015-00	. FUSE, 15 AMP	1
-17	12798-000-00	. SWITCH, Toggle	1
-18	63434-000-00	. BRACKET	1

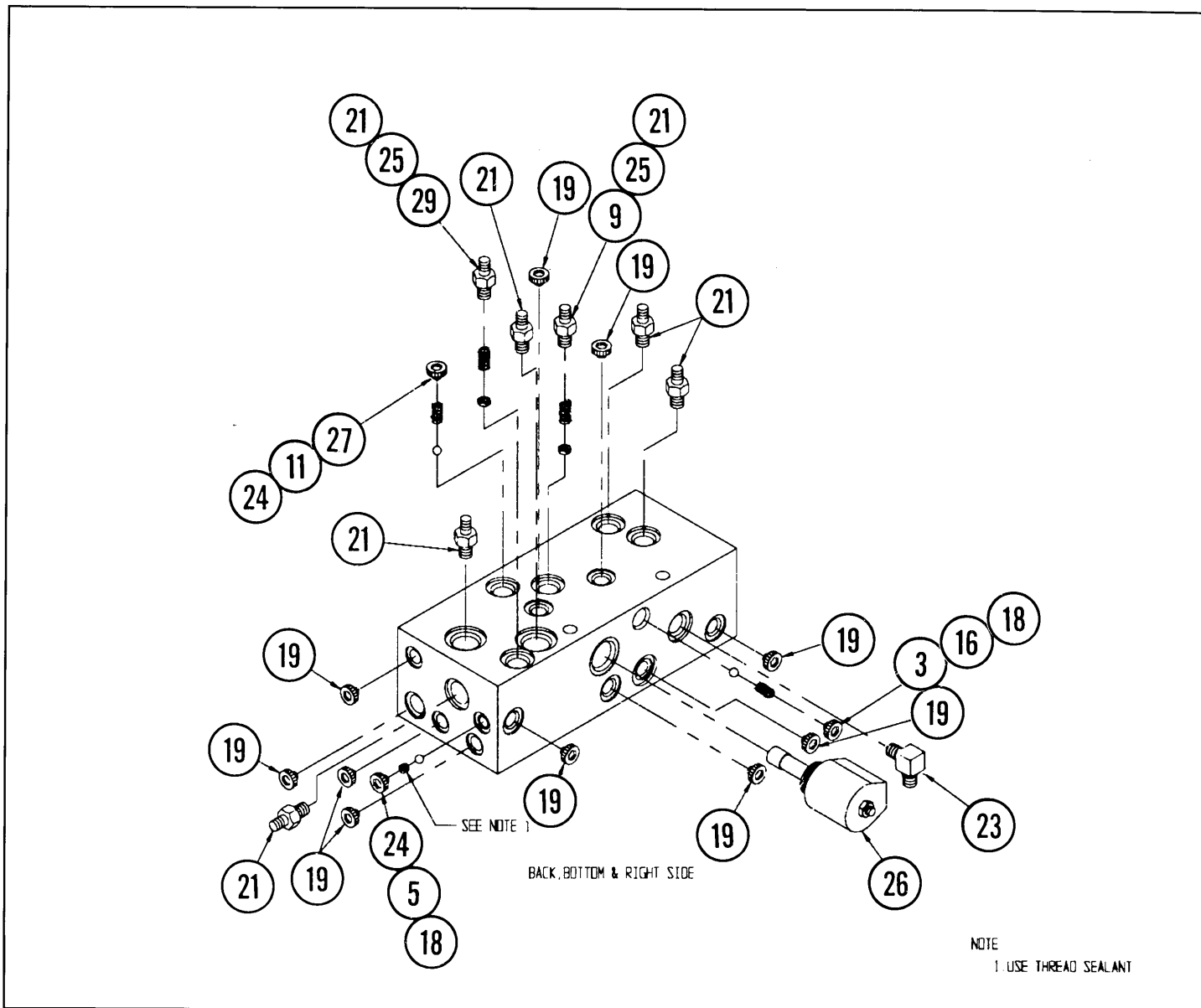

Figure 7-10. Hydraulic Manifold Assembly, XL-C Series

ITEM	PART	DESCRIPTION	QTY.
7-10	No Number	HYDRAULIC MANIFOLD ASSEMBLY, XL-C Series	REF
-2	63218-000-00	. VALVE, Manifold	1
-3	61827-000-00	. BALL, 7/16 Dia. STL	3
-4	61819-000-00	. PISTON ASSEMBLY	4
-5	61728-000-00	. ORIFICE	2
-6	60390-000-00	. CARTRIDGE, Relief Valve	1
-7	60388-000-00	. CARTRIDGE, Needle Valve	1
-8	29925-000-00	. CONNECTOR CABLE	2
-9	15919-000-00	. ORIFICE	1
-10	15900-000-00	. VALVE, Counterbalance	2
-11	15799-000-00	. SPRING, Compress	4
-12	61797-000-00	. VALVE, N.C. Lift Solenoid	1
-13	15763-000-00	. VALVE, Steering Solenoid	1
-14	15762-000-00	. VALVE, N.O. Solenoid	2

ITEM	PART No.	DESCRIPTION	QTY.
-15	15760-000-00	. VALVE, Drive Solenoid	1
-16	13987-005-00	. SPRING, Valve	2
-17	12004-008-00	. FITTING, Plug	1
-18	12004-006-00	. FITTING, Plug	2
-19	12004-004-00	. FITTING, Plug	21
-20	12004-002-00	. FITTING, Plug	3
-21	11941-005-00	. FITTING, Adaptor	7
-23	11934-004-00	. FITTING, Elbow	1
-24	05135-000-00	. BALL, 5/16 Dia. STL	5
-25	05133-000-00	. SPRING, Valve	2
-26	15764-000-00	. VALVE, Lower N.C. Solenoid	1
-27	20021-000-00	. FITTING, Plug	1
-28	63121-000-00	. VALVE, Steer Bypass Solenoid	1
-29	15919-000-00	. ORIFICE (XL-19C/19CW)	1
	15919-001-00	. ORIFICE (XL-24C/24CW)	1

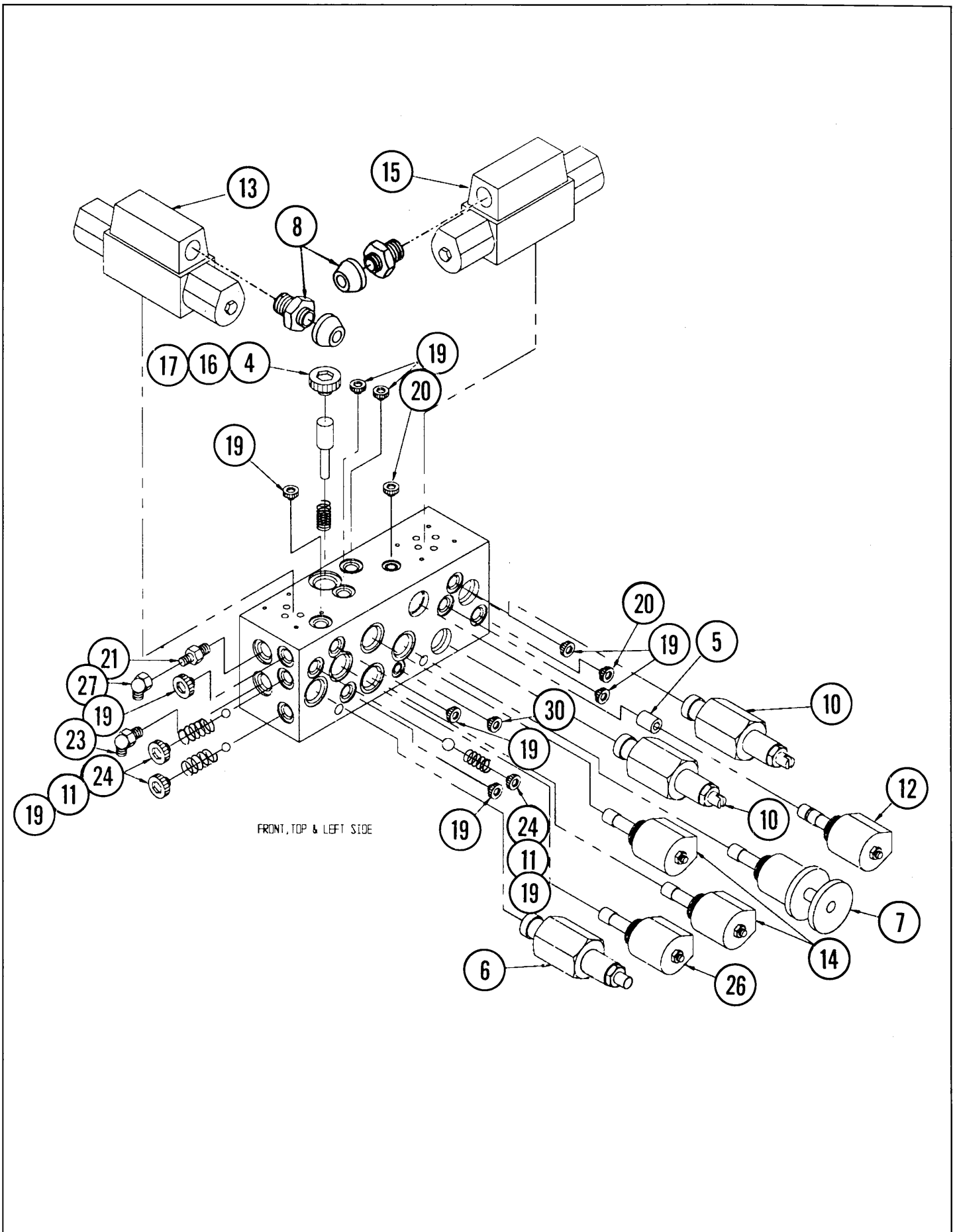

Figure 7-10. Hydraulic Manifold Assembly, XL-C Series

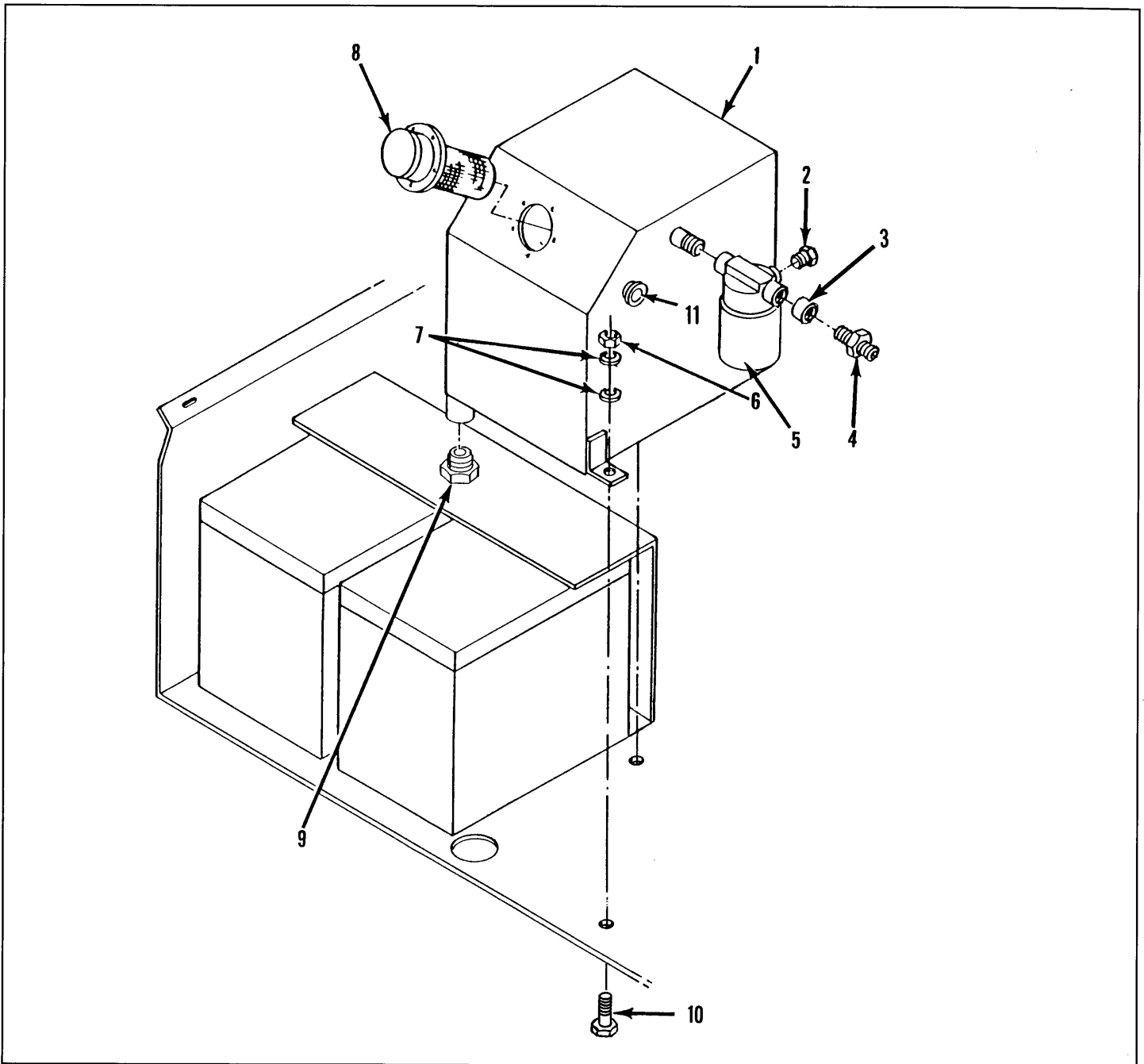

Figure 7-11. Hydraulic Tank Installation, XL-C Series

ITEM	PART	DESCRIPTION	QTY.
7-11	No Number	HYDRAULIC TANK INSTALLATION XL-C Series	REF
-1	63539-000-00	. HYDRAULIC TANK WELDMENT	1
-2	11920-000-00	. PLUG	1
-3	11661-000-00	. FITTING, Reducer	1
-4	11939-010-00	. FITTING, Straight	1
-5	05154-001-00	. FILTER	1
	05154-002-00	.. ELEMENT, Filter	1

ITEM	PART No.	DESCRIPTION	QTY.
-6	11248-000-00	. LOCKNUT, HEX 1/4-20 UNC	2
-7	11240-004-00	. WASHER, Flat 1/4 Dia.	4
-8	05963-000-00	. FILLER	1
-9	21305-006-00	. PLUG	1
-10	11252-008-00	. SCREW, HHC 1/4-20 UNC x 1	2
-11	63979-006-00	. SIGHT GUAGE	1

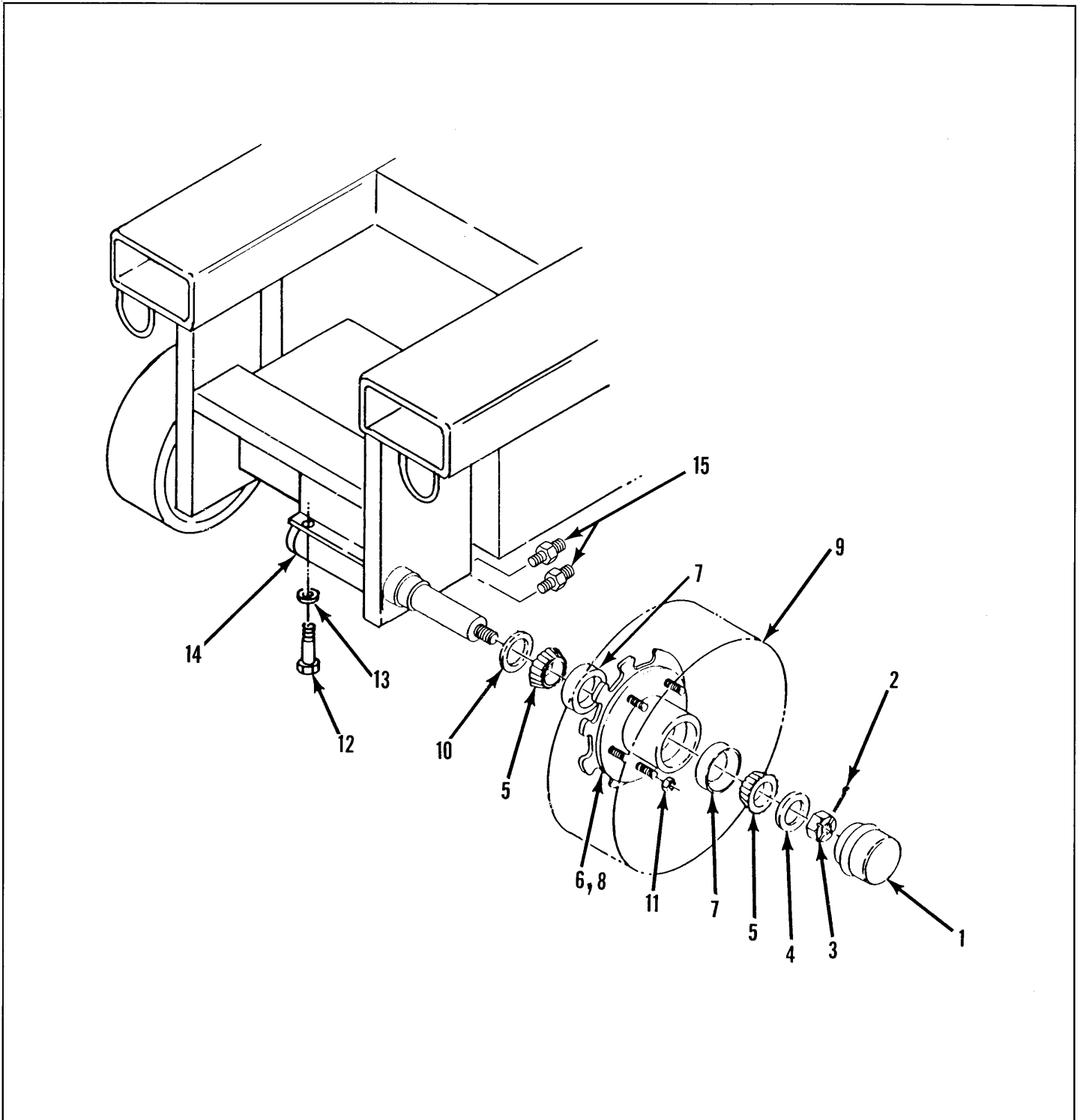

Figure 7-12. Rear Wheel and Hub Assembly, XL-19C

ITEM	PART	DESCRIPTION	QTY.
7-12	No Number	REAR WHEEL AND HUB ASSEMBLY, XL-19C (See Figure 7-3 for NHA)	REF
-1	05078-000-00	. CAP, Dust	2
-2	11753-012-00	. PIN, Cotter	2
-3	11274-016-00	. NUT, Slotted HEX 1-1/4 UNF	2
-4	11239-016-00	. WASHER, Flat 1 Dia. ASTM	2
-5	11775-011-00	. CONE, Bearing	4
-6	60742-000-00	. HUB AND ROTOR WELDMENT-R.H.	1
-7	11776-004-00	. CUP, Bearing	4

ITEM	PART No.	DESCRIPTION	QTY.
-8	05100-001-00	. HUB-L.H., (Not Shown)	1
-9	61826-000-00	. WHEEL ASSEMBLY	2
-10	05104-000-00	. SEAL, Grease	2
-11	05105-000-00	. NUT, Lug	10
-12	11254-010-00	. SCREW, HHC 3/8-16 UNC GR5 x 1-1/4	4
-13	11240-006-00	. WASHER, Flat 3/8 Dia.	4
-14	60479-000-00	. CYLINDER, Brake	1
	60211-014-00	. SEAL KIT	1
-15	11939-010-00	. FITTING, Straight	2

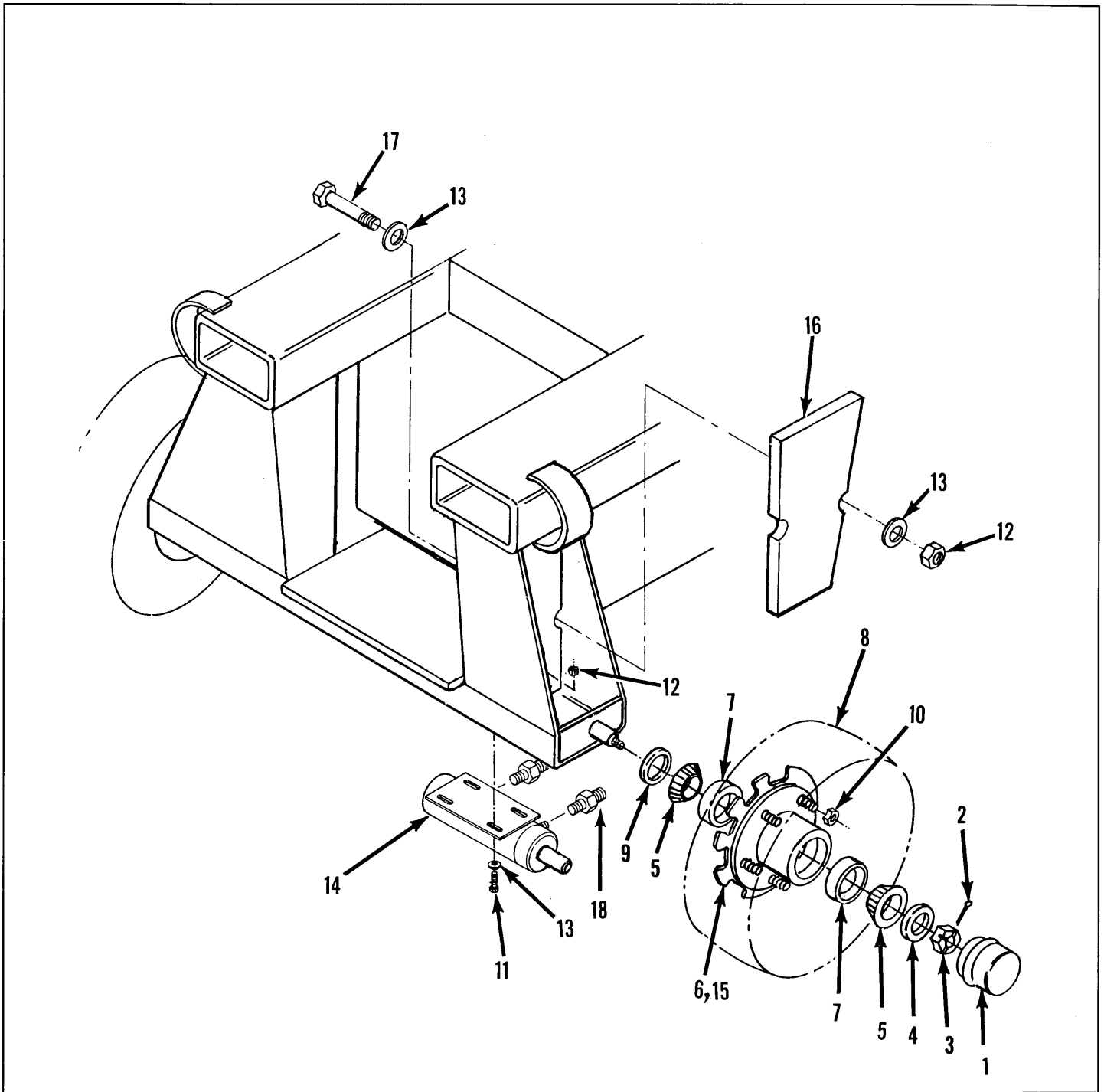

Figure 7-13. Rear Wheel and Hub Assembly, XL-19CW, XL-24C and XL-24CW

ITEM	PART	DESCRIPTION	QTY.
7-13	No Number	REAR WHEEL AND HUB ASSEMBLY, XL-19CW, XL-24C & XL-24CW	REF
-1	05078-000-00	. CAP, Dust	2
-2	11753-000-00	. PIN, Cotter	2
-3	11274-000-00	. NUT, Slotted HEX 1-1/4 UNF	2
-4	11239-016-00	. WASHER, Flat 1 Dia. ASTM	2
-5	11775-011-00	. CONE, Bearing	4
-6	60742-000-00	. HUB AND ROTOR WELDMENT-R.H.	1
-7	11776-004-00	. CUP, Bearing	4
-8	61826-000-00	. WHEEL ASSEMBLY	2
-9	05104-000-00	. SEAL, Grease	2

ITEM	PART No.	DESCRIPTION	QTY.
-10	05105-000-00	. NUT, 3/8-16 UNC ESNA	4
-11	11254-010-00	. SCREW, HHC 3/8-16 UNC ESNA	4
-12	11248-006-00	. NUT, 3/8-16 UNC GR5 x 1-1/4	4
-13	11240-006-00	. WASHER, Flat 3/8 Dia.	4
-14	60479-000-00	. CYLINDER, Brake	1
	60211-014-00	. SEAL KIT	1
-15	05100-001-00	. HUB-L.H., (Not Shown)	1
-16	61989-000-00	. BALLAST-Rear (XL-24C Only)	8
-17	11254-044-00	. SCREW, HHC 3/8-16 UNC GR5 x 5-1/2 (XL-24C Only)	
-18	11939-010-00	. FITTING, Staight	2

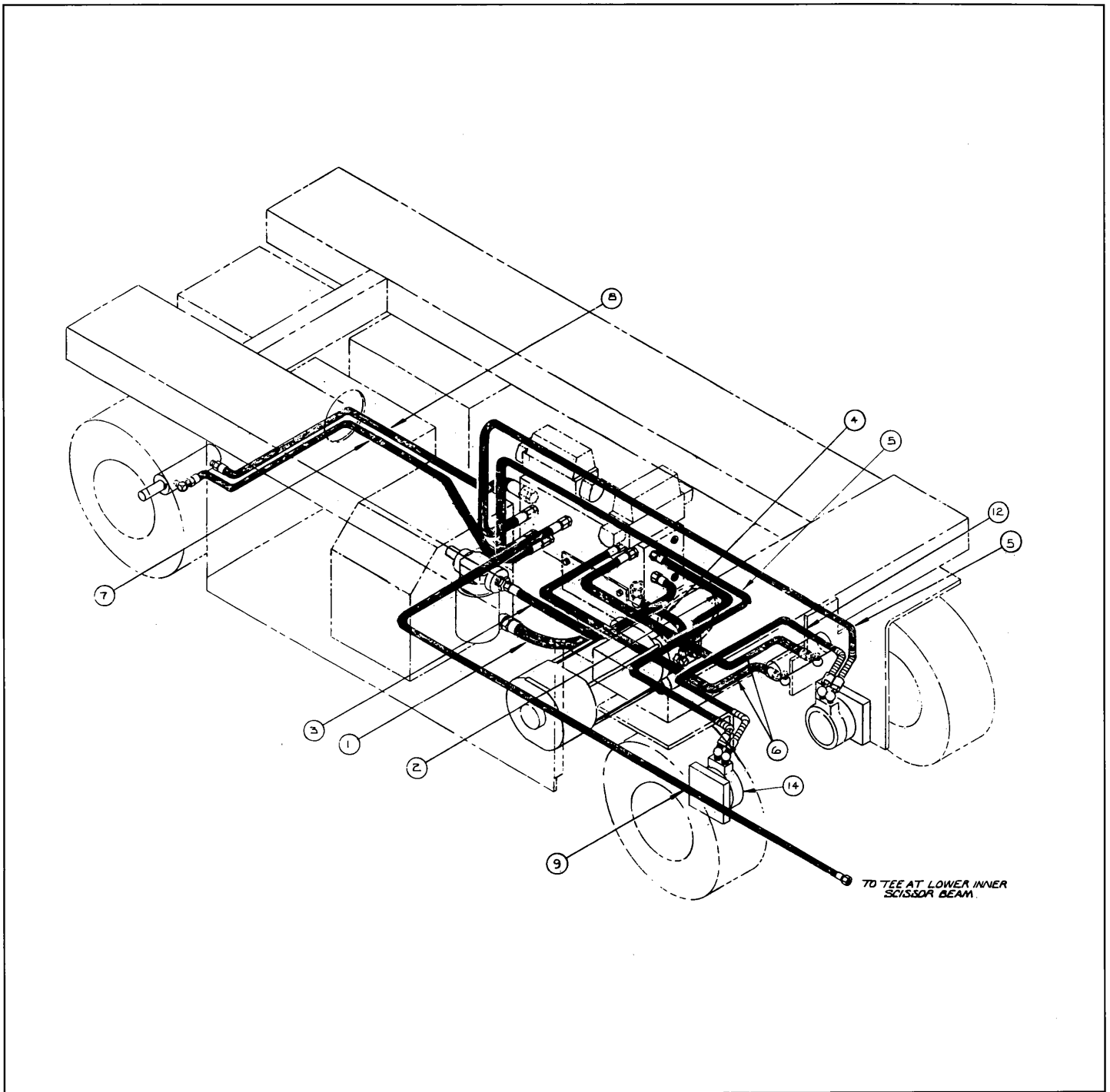

Figure 7-14. Hose Kit Installation, XL-19C

ITEM	PART	DESCRIPTION	QTY.
7-14	61805-000-00	HOSE KIT INSTALLATION, XL-19C	REF
-1	61789-001-00	.HOSE ASSY. 3/8 x 15-1/2 (Suction)	1
-2	61791-003-00	.HOSE ASSY. 3/8 x 14 (Steer Power)	1
-3	61791-004-00	.HOSE ASSY. 3/8 x 33-1/2 (Steer Return)	1
-4	60861-024-00	.HOSE ASSY. 3/8 x 17 (Lift/Drive Power)	1
-5	60889-005-00	.HOSE ASSY. W/ GUARD 3/8 x 50 (Drive)	2
-6	60861-026-00	.HOSE ASSY. 3/8 x 31 (Steer)	2

ITEM	PART	DESCRIPTION	QTY.
-7	60861-002-00	.HOSE ASSY. 3/8 x 42-1/2 (Brake)	1
-8	62192-006-00	.HOSE ASSY. 1/4 x 39 (Brake Return)	1
-9	60861-017-00	.HOSE ASSY. 3/8 x 100 (Lift)	1
-10	60861-027-00	.HOSE ASSY. 3/8 x 99-1/2 (Lift)	1
-11	60861-019-00	.HOSE ASSY. 3/8 x 22 (Lift)	1
-12	60889-006-00	.HOSE ASSY. 3/8 x 45 (X-Over)	1

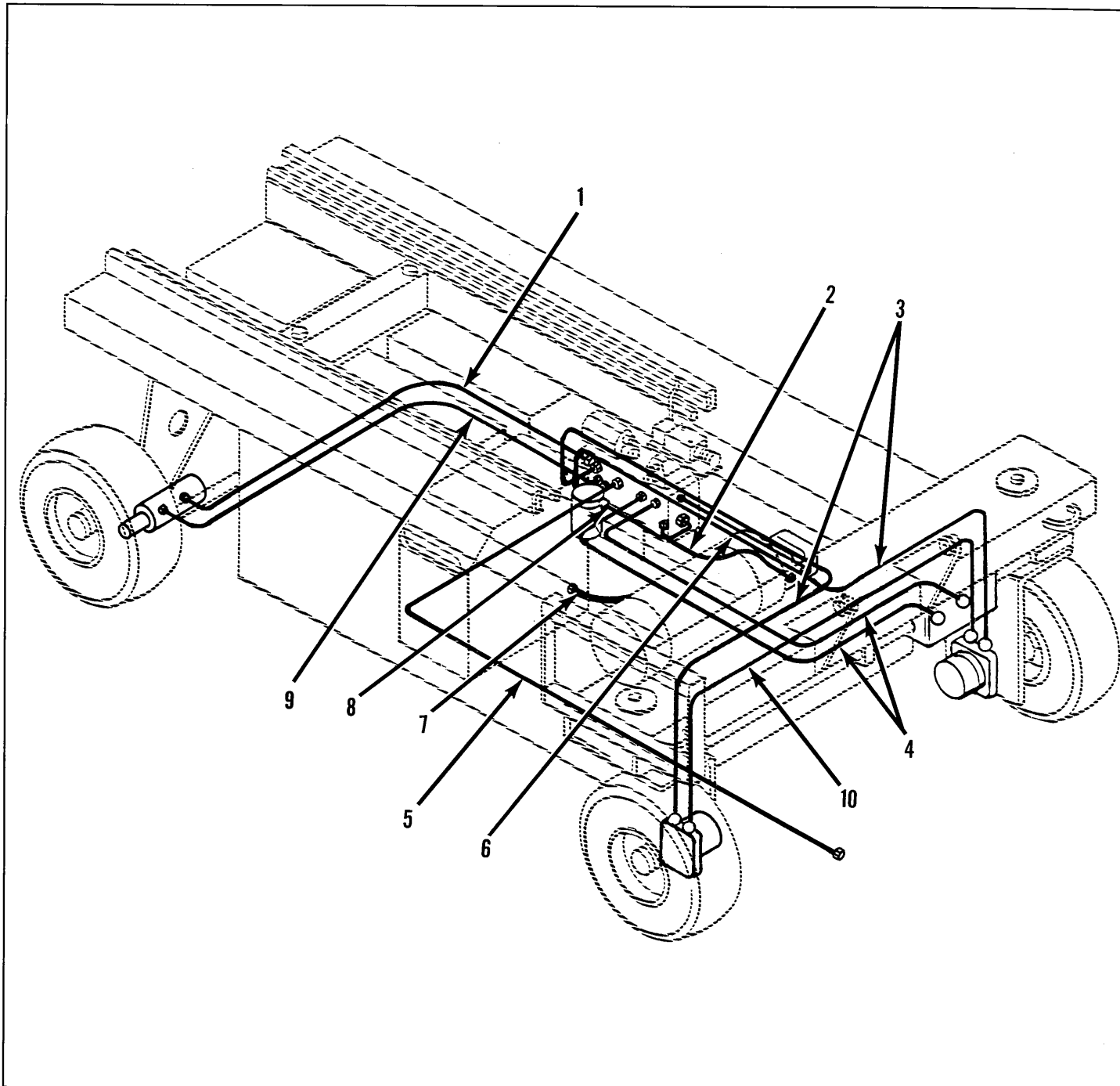

Figure 7-15. Hose Kit Installation, XL-19CW, XL-24C and XL-24CW

ITEM	PART	DESCRIPTION	QTY.
7-15	61856-000-00	HOSE KIT INSTALLATION, XL-19CW	REF
	61961-000-00	HOSE KIT INSTALLATION, XL-24C	
	63767-000-00	HOSE KIT INSTALLATION, XL-24CW	
-1	62192-008-00	. HOSE ASSEMBLY 1/4 x 50	1
-2	60861-024-00	. HOSE ASSEMBLY 3/8 x 17	1
-3	60889-007-00	. HOSE ASSEMBLY 3/8 x 60	2

ITEM	PART	DESCRIPTION	QTY.
-4	60861-003-00	. HOSE ASSEMBLY 3/8 x 39-1/2	2
-5	60861-043-00	. HOSE ASSEMBLY 3/8 x 103	1
-6	61791-003-00	. HOSE ASSEMBLY 3/8 x 14	1
-7	61789-001-00	. HOSE ASSEMBLY 3/8 x 15-1/2	1
-8	61791-004-00	. HOSE ASSEMBLY 3/8 x 33-1/2	1
-9	60861-047-00	. HOSE ASSEMBLY 3/8 x 54-1/2	1
-10	60809-008-00	. HOSE ASSEMBLY 3/8 x 64	1

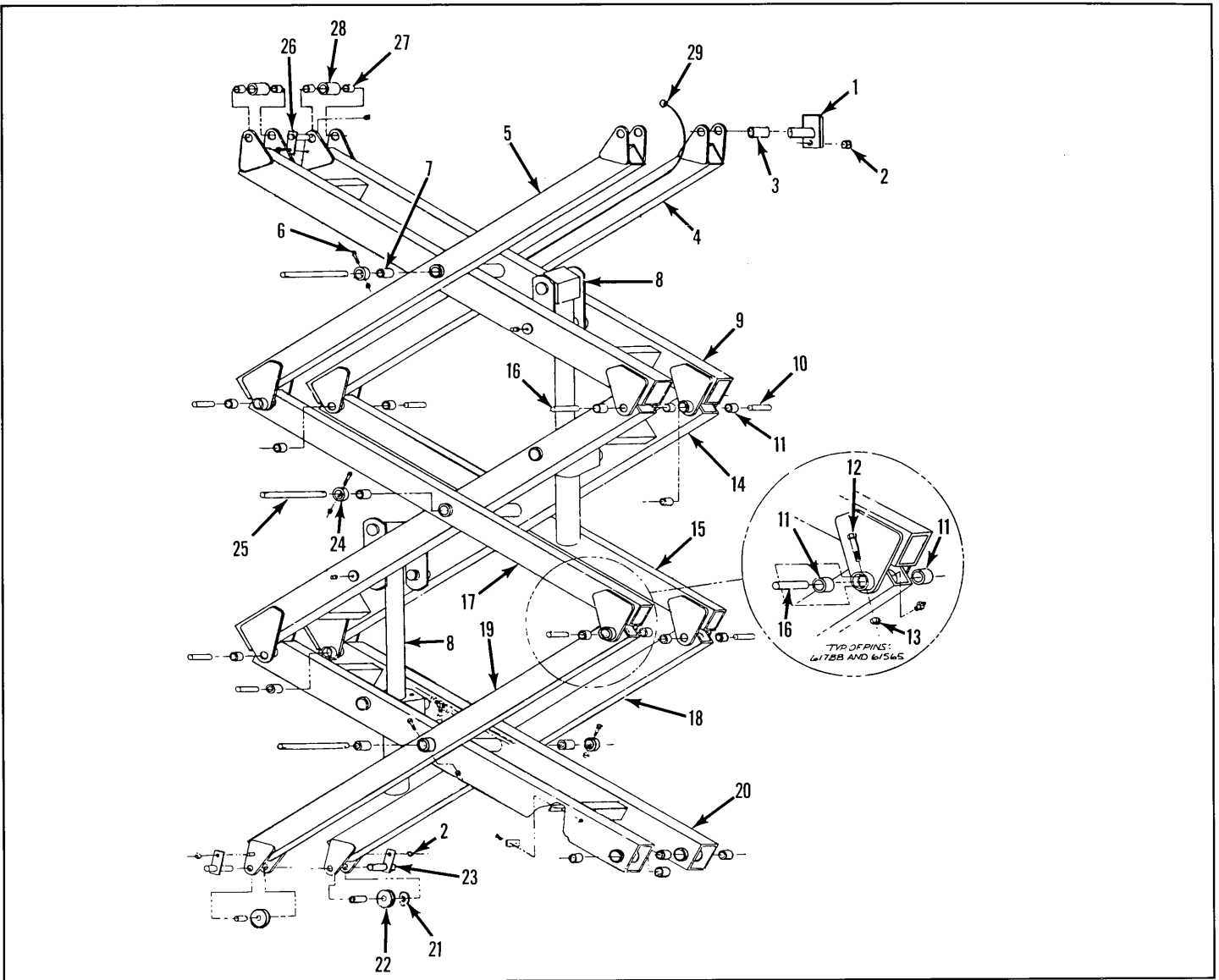

Figure 7-16. Scissors Assembly, XL-19C and XL-19CW

ITEM	PART	DESCRIPTION	QTY.
7-16	No Number	SCISSORS ASSEMBLY, XL-19C & XL-19CW	REF
-1	61506-000-00	. WELDMENT, Pin	2
-2	11248-006-00	. LOCKNUT, 3/8-16 UNC	10
-3	27931-012-00	. BEARING	4
-4	61756-000-00	. ARM WELDMENT, Upper-outer-L.H.	1
-5	61757-000-00	. ARM WELDMENT, Upper-outer-R.H.	1
-6	11254-022-00	. SCREW, HHC 3/8-16 UNC GR5 x 2-3/4	10
-7	27931-006-00	. BEARING	6
-8	No Number	. LIFT CYLINDER Installation (See Figure 7-18)	2
-9	61723-000-00	. FRAME WELDMENT, Upper-inner	1
-10	61565-000-00	. PIN	6
-11	11780-031-00	. BEARING	20
-12	11253-016-00	. SCREW, SCREW HHC 5/16-18 UNC GR5 x 2	8
-13	11248-005-00	. LOCKNUT, HEX 5/16-18 UNC	10
-14	61722-000-00	. FRAME WELDMENT, Center-inner	1

ITEM	PART No.	DESCRIPTION	QTY.
-15	61755-000-00	. ARM WELDMENT, Center-outer-L.H.	1
-16	61788-000-00	. PIN	4
-17	61754-000-00	. ARM WELDMENT, Center-outer-R.H.	1
-18	61459-000-00	. ARM WELDMENT, Outer-lower-L.H.	1
-19	61469-000-00	. ARM WELDMENT, Outer-lower-R.H.	1
-20	61758-000-00	. FRAME WELDMENT, Lower-inner	1
-21	61536-000-00	. WASHER	4
-22	60880-000-00	. WHEEL, Lower	2
-23	60788-000-00	. PIN WELDMENT	2
-24	61471-000-00	. COLLAR, Pin retainer	3
-25	61470-000-00	. PIN, Center Pivot	3
-26	61472-000-00	. PIN WELDMENT	2
-27	27931-012-00	. BEARING	4
-28	61473-000-00	. ROLLER	2
-29	60861-017-00	. HOSE ASSEMBLY 3/8 x 100	1
	60861-019-00	. HOSE ASSEMBLY 3/8 x 22	1
	60861-027-00	. HOSE ASSEMBLY 3/8 x 97-1/2	1

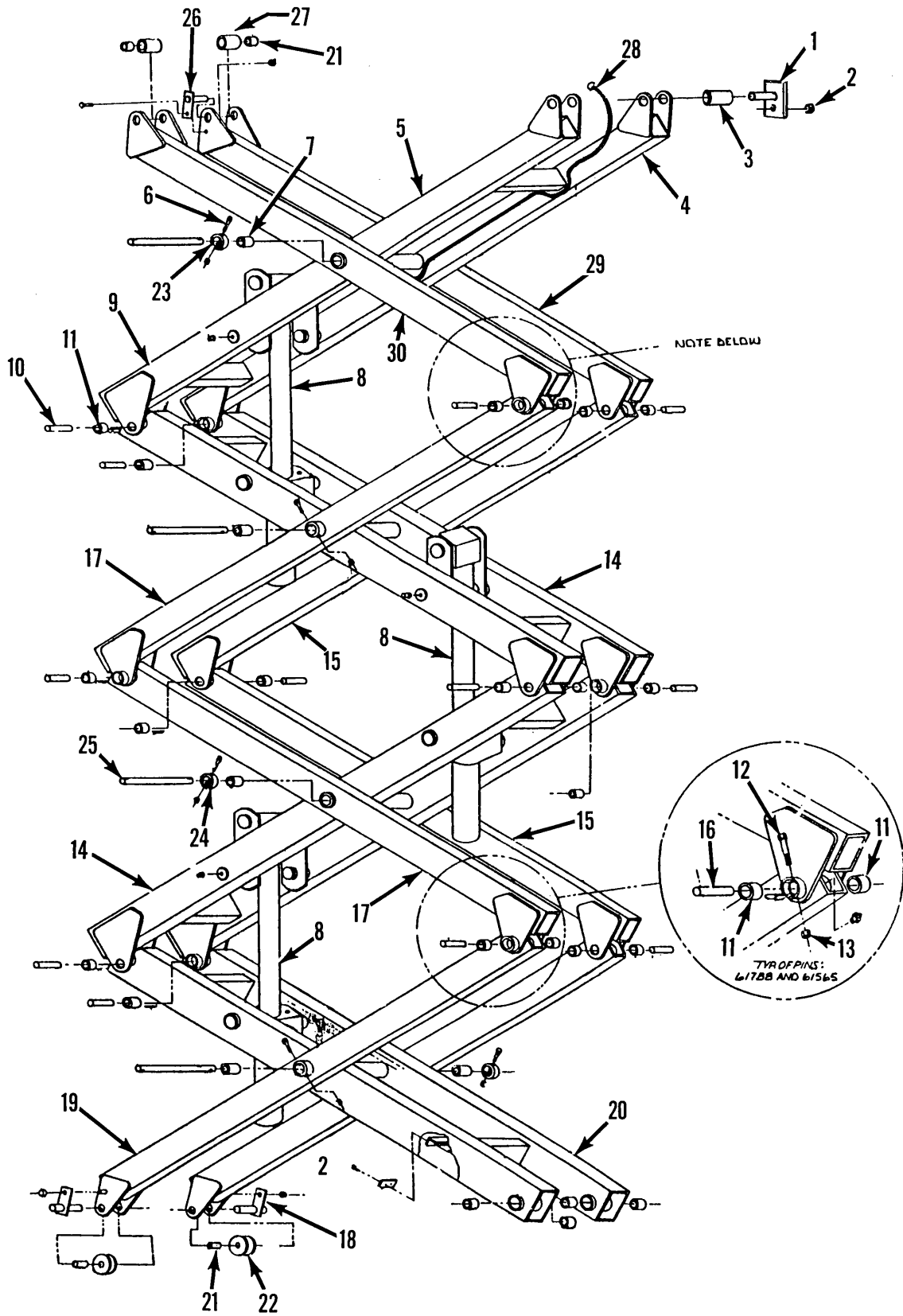

Figure 7-17. Scissors Assembly, XL-24C and XL-24CW

Figure 7-17. Scissors Assembly, XL-24C and XL-24CW

ITEM	PART	DESCRIPTION	QTY.
7-17	No Number	SCISSORS ASSEMBLY, XL-19C & XL-19CW	REF
-1	61506-000-00	. WELDMENT, Pin	2
-2	11248-006-00	. LOCKNUT, 3/8-16 UNC	10
-3	27931-012-00	. BEARING	4
-4	61756-000-00	. ARM WELDMENT, Upper-outer-L.H.	1
-5	61757-000-00	. ARM WELDMENT, Upper-outer-R.H.	1
-6	11254-022-00	. SCREW, HHC 3/8-16 UNC GR5 x 2-3/4	10
-7	27931-006-00	. BEARING	6
-8	No Number	. LIFT CYLINDER Installation (See Figure 7-18)	2
-9	61723-000-00	. FRAME WELDMENT, Upper-inner	1
-10	61565-000-00	. PIN	4
-11	11780-031-00	. BEARING	28
-12	11253-016-00	. SCREW, HHC 5/16-18 UNC GR5 x 2	12
-13	11248-005-00	. LOCKNUT, HEX 5/16-18 UNC	12
-14	61722-000-00	. WELDMENT, Frame Center-outer-L.H.	2

ITEM	PART No.	DESCRIPTION	QTY.
-15	61755-000-00	. ARM WELDMENT, Center-outer-L.H.	2
-16	61788-000-00	. PIN	4
-17	61754-000-00	. ARM WELDMENT, Center-outer-R.H.	2
-18	61459-000-00	. ARM WELDMENT, Outer-lower-L.H.	1
-19	61469-000-00	. ARM WELDMENT, Outer-lower-R.H.	1
-20	61758-000-00	. FRAME WELDMENT, Lower-inner	1
-21	27931-006-00	. BEARING	4
-22	61876-000-00	. WHEEL, Lower	2
-23	60788-000-00	. PIN WELDMENT	2
-24	61471-000-00	. COLLAR, Pin retainer	3
-25	61470-000-00	. PIN, Center Pivot	3
-26	61472-000-00	. PIN WELDMENT	2
-27	61947-000-00	. ROLLER	4
-28	60861-017-00	. HOSE ASSEMBLY, 3/8 x 100	1
	60861-019-00	. HOSE ASSEMBLY, 3/8 x 22	2
	60861-027-00	. HOSE ASSEMBLY, 3/8 x 97-1/2	2

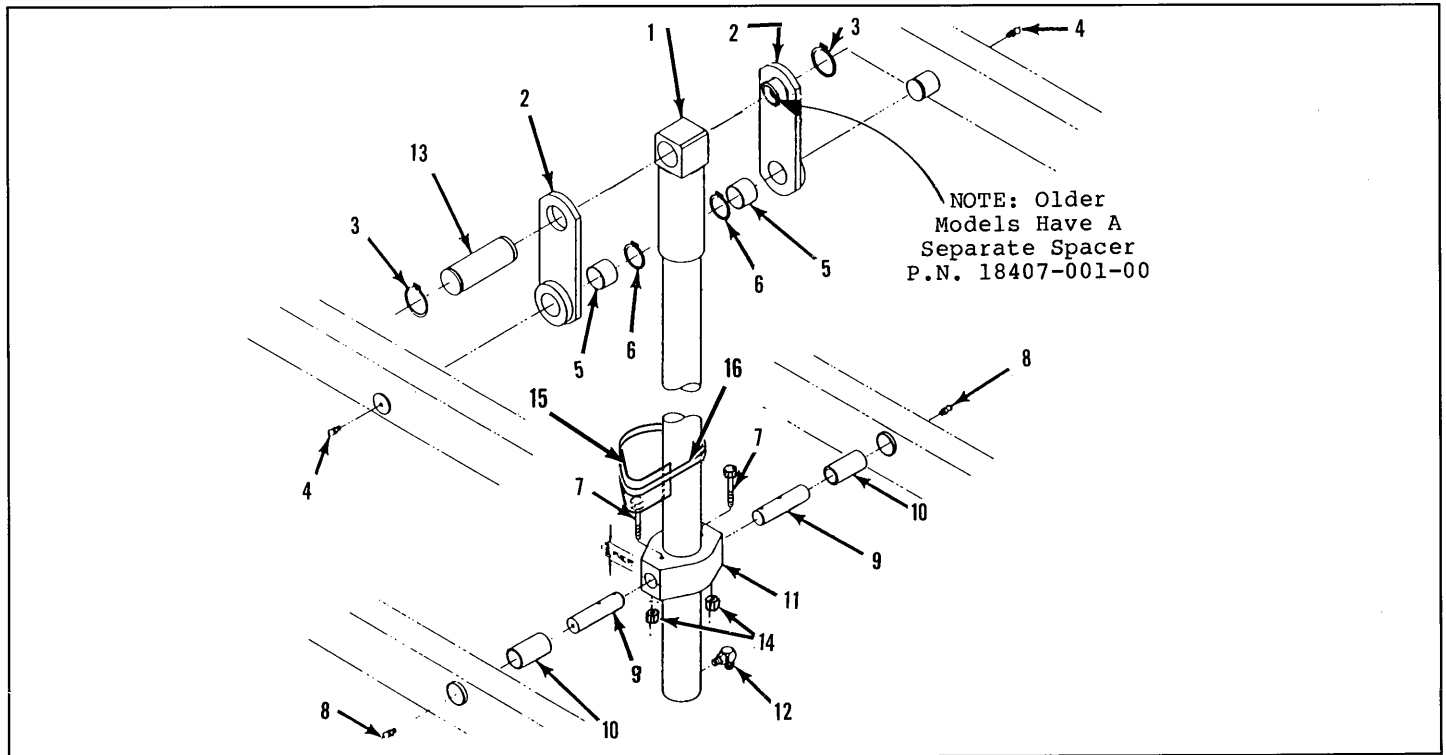

Figure 7-18. Lift Cylinder Installation, XL-C Series

ITEM	PART	DESCRIPTION	QTY.
7-18	No Number	LIFT CYLINDER INSTALLATION, XL-C Series	REF
-1	12794-000-00	. CYLINDER, Lift	2
	63249-000-00	. CYLINDER, Lift - Third (XL-24C & XL-24CW only)	1
	12794-014-00	. SCREW, Bleeder	1
	14413-001-00	. FUSE, Velocity	1
	12794-013-00	. SEAL KIT	1
-2	60844-000-00	. WELDMENT, Plate	4
-3	11764-034-00	. RING, Retaining	4
-4	13336-001-00	. FITTING, Grease 1/8-27 NPT	4
-5	60845-000-00	. BEARING	4

ITEM	PART	DESCRIPTION	QTY.
-6	11764-027-00	. RING, Retaining	4
-7	12553-028-00	. BOLT, 1/4-20 SOC HD GR5 x 3-1/2	4
-8	13336-011-00	. FITTING, Grease 1/4-28 UNF	4
-9	11783-008-00	. BEARING	4
-10	61468-000-00	. PIN, Pivot Cylinder Collar	4
-11	61474-000-00	. COLLAR, Cylinder	2
-12	11934-007-00	. FITTING, Elbow	2
-13	61467-000-00	. PIN, Cylinder	2
-14	11248-004-00	. LOCKNUT, HEX 1/4-20 UNC	4
-15	63247-000-00	. ANGLE, Cylinder	1
-16	20541-028-00	. CLAMP, Hose SAE #56	1

061799-001

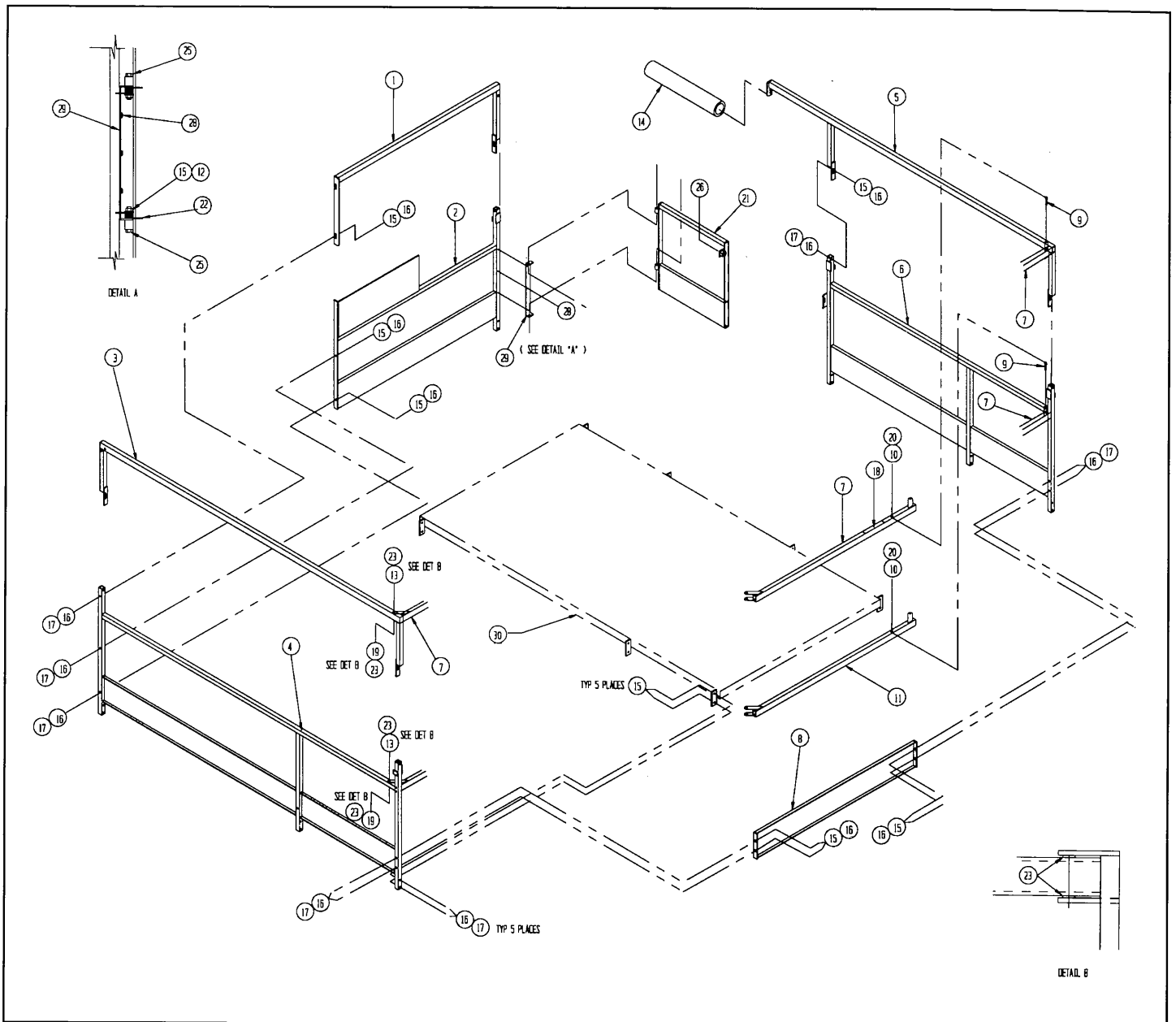

Figure 7-19. Fold Down Guardrail Installation, XL-19C

ITEM	PART	DESCRIPTION	QTY.
7-19	63576-000-00	FOLD DOWN GUARDRAIL INSTALL., XL-19C	REF
-1	63244-002-00	. GUARDRAIL, Front-upper Weldment	1
-2	61971-001-00	. GUARDRAIL, Front-lower Weldment	1
-3	61977-002-00	. GUARDRAIL, Upper L.H. Weldment	1
-4	61978-001-00	. GUARDRAIL, Lower L.H. Weldment	1
-5	63243-002-00	. GUARDRAIL, Upper R.H. Weldment	1
-6	61991-001-00	. GUARDRAIL, Lower R.H. Weldment	1
-7	63161-000-00	. GUARDRAIL, Rear Weldment	1
-8	63157-000-00	. TOEBOARD, Rear Weldment	1
-9	10414-000-00	. LOCKING PIN ASSEMBLY	2
-10	26553-000-00	. POP RIVET 3/16 x 3/8 Grip	2
-11	63272-000-00	. WELDMENT, Midrail	1
-12	14996-006-00	. WASHER, Flat 3/8 SAE	2
-13	11253-022-00	. SCREW, Cap HEX HD 5/16-18 x 2-3/4	2
-14	10191-001-00	. BUMPER	1

ITEM	PART No.	DESCRIPTION	QTY.
-14	10191-001-00	. BUMPER	1
-15	11248-006-00	. NUT, ESNA 3/8-16	26
-16	11240-006-00	. WASHER, Flat 3/8 Dia.	50
-17	11254-016-00	. SCREW, Cap HEX HD 3/8-16 x 2	25
-18	61787-000-00	. DECAL, Danger	1
-19	11248-005-00	. NUT, ESNA 5/16-18	2
-20	11240-003-00	. WASHER, Flat 3/16	2
-21	63271-000-00	. WELDMENT, Gate	1
-22	63270-000-00	. SPRING, Torsion	2
-23	11250-000-00	. WASHER, Flat 5/16 Dia.	4
-25	11254-022-00	. SCREW, Cap HEX HD 3/8-16 x 2-3/4	2
-26	03570-000-00	. PIN, Retaining Assembly	1
-27	11253-000-00	. SCREW, Cap HEX HD 5/16-18 x 2	1
-28	26527-004-00	. SCREW, Self Tap 1/4-20 x 1/2	3
-29	63315-000-00	. HINGE, Channel	1
-30	61718-000-00	. WELDMENT, Platform	1

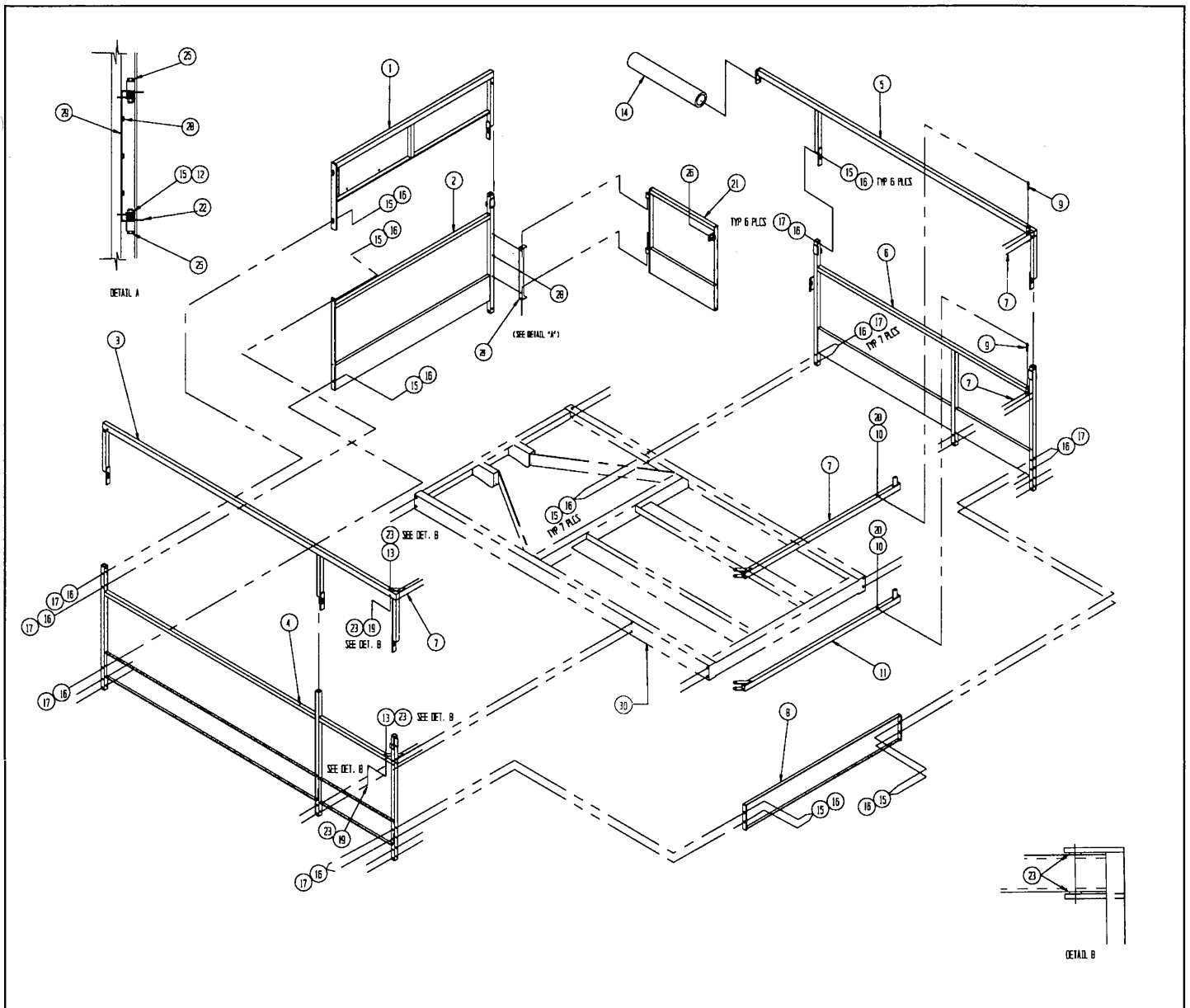

Figure 7-20. Fold Down Guardrail Installation, XL-19CW, XL-24C and XL-24CW

ITEM	PART	DESCRIPTION	QTY.
7-20	63775-000-00	FOLD DOWN GUARDRAIL INSTALL., XL-19CW, XL-24C and XL-24CW	REF
-1	63244-002-00	. GUARDRAIL, Front-upper Weldment	1
-2	61971-001-00	. GUARDRAIL, Front-lower Weldment	1
-3	61977-002-00	. GUARDRAIL, Upper L.H. Weldment	1
-4	61978-001-00	. GUARDRAIL, Lower L.H. Weldment	1
-5	63243-002-00	. GUARDRAIL, Upper R.H. Weldment	1
-6	61991-001-00	. GUARDRAIL, Lower R.H. Weldment	1
-7	63161-000-00	. GUARDRAIL, Rear Weldment	1
-8	63157-000-00	. TOEBOARD, Rear Weldment	1
-9	10414-000-00	. LOCKING PIN ASSEMBLY	2
-10	26553-000-00	. POP RIVET 3/16 x 3/8 Grip	2
-11	63272-000-00	. WELDMENT, Midrail	1
-12	14996-006-00	. WASHER, Flat 3/8 SAE	2
-13	11253-022-00	. SCREW, Cap HEX HD 5/16-18 x 2-3/4	2
-14	10191-001-00	. BUMPER	1

ITEM	PART No.	DESCRIPTION	QTY.
-15	11248-006-00	. NUT, ESNA 3/8-16	26
-16	11240-006-00	. WASHER, Flat 3/8 Dia.	50
-17	11254-016-00	. SCREW, Cap HEX HD 3/8-16 x 2	25
-18	61787-000-00	. DECAL, Danger	1
-19	11248-005-00	. NUT, ESNA 5/16-18	2
-20	11240-003-00	. WASHER, Flat 3/16	2
-21	63271-000-00	. WELDMENT, Gate	1
-22	63270-000-00	. SPRING, Torsion	2
-23	11250-000-00	. WASHER, Flat 5/16 Dia.	4
-25	11254-022-00	. SCREW, Cap HEX HD 3/8-16 x 2-3/4	2
-26	03570-000-00	. PIN, Retaining Assembly	1
-27	11253-000-00	. SCREW, Cap HEX HD 5/16-18 x 2	1
-28	26527-004-00	. SCREW, Self Tap 1/4-20 x 1/2	3
-29	63315-000-00	. HINGE, Channel	1
-30	63621-000-00	. WELDMENMT, Platform XL-19CW	1
	63773-000-00	. WELDMENMT, Platform XL-24C/CW	1

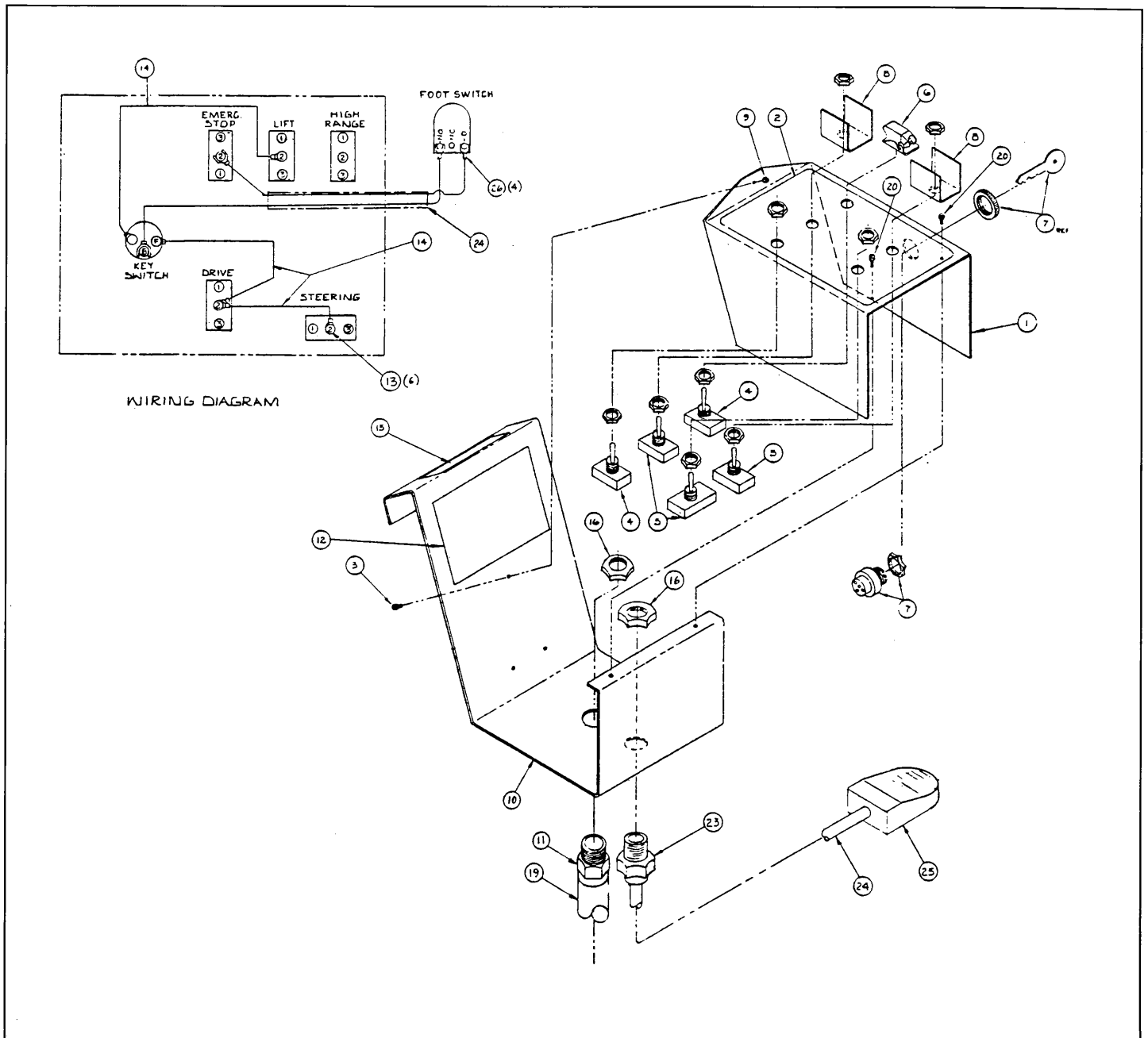

Figure 7-21. Controller Assembly

ITEM	PART	DESCRIPTION	QTY.
7-21	63404-000-00	CONTROLLER ASSEMBLY (See Figure 7-1 for NHA)	REF
-1	61809-000-00	. CONSOLE, Controller	1
-2	61813-000-00	. DECAL, Controller	1
-3	11708-000-00	. SCREW, UNC RD HD 8-32 x 1/2	1
-4	12797-000-00	. SWITCH, Toggle	2
-5	12798-000-00	. SWITCH, Toggle	3
-6	29936-006-00	. GUARD, Switch	1
-7	15935-000-00	. KEYSWITCH	1
	10155-000-00	.. KEYSWITCH	1
	10155-001-00	.. KEY Only	1
-8	08271-000-00	. GUARD, Toggle Switch	2
-9	11248-002-00	. LOCKNUT, UNC HEX 8-32	1

ITEM	PART No.	DESCRIPTION	QTY.
-10	63452-000-00	. HANGER, Controller	1
-11	29925-003-00	. CONNECTOR, Cable	1
-12	60865-000-00	. DECAL, Before Operating	1
-14	29456-000-00	. WIRE, 16 AWG THHN STRD COP YEL	38in.
-15	61515-000-00	. DECAL, Lift Here	1
-16	29939-002-00	. LOCKNUT	2
-20	14073-006-00	. SCREW, Self Tap UNC HEX 8-32 x 3/4	2
-21	63088-000-00	. CONTROLLER, Channel	1
-22	26553-004-00	. RIVET, Pop 3/16 Dia.	2
-23	29925-000-00	. CONNECTOR	1
-24	29495-099-00	. CABLE 14-3	6ft.
-25	63906-000-00	. FOOT SWITCH	1
-26	29610-000-00	. CONNECTOR, Fork Terminal 10-12	4

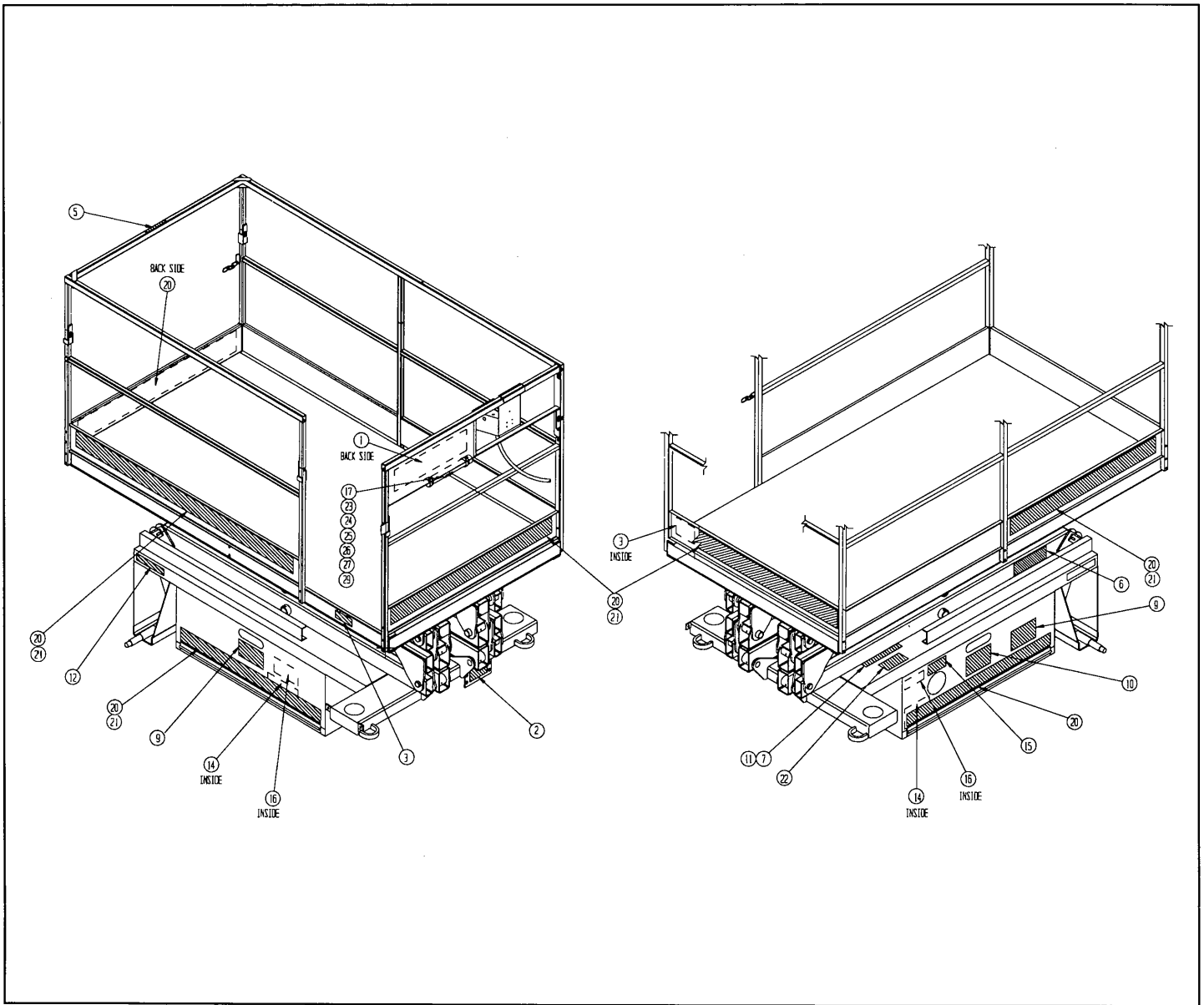

Figure 7-22. Decal Kit Installation, XL-C Series

ITEM	PART	DESCRIPTION	QTY.
7-22	61833-002-00	DECAL KIT INSTALLATION, XL-19C	REF
	61855-002-00	DECAL KIT INSTALL., XL-19CW	REF
	61953-002-00	DECAL KIT INSTALL., XL-24C	REF
	61953-003-00	DECAL KIT INSTALL., XL-24CW	REF
-1	61750-000-00	. DECAL, Danger Safety Rules	1
-2	61531-000-00	. DECAL, Caution	1
-3	61520-000-00	. DECAL, Max Load 550 Lbs. XL-19C	2
	08442-003-00	. DECAL, Max Load 1000 Lbs. XL-19CW & XL-24CW	2
	08442-006-00	. DECAL, Max Load 750 Lbs. XL-24C	2
-5	61787-000-00	. DECAL, Danger Guardrails	1
-6	63255-000-00	. DECAL, Scissors Brace	1
-7	61205-000-00	. DECAL, Name Plate	1
-9	27993-000-00	. DECAL, Lower Platform	2
-10	27992-000-00	. DECAL, Caution Do Not Adjust	1
-11	26551-000-00	. RIVET, Pop 1/8 .188-.250 Grip	4

ITEM	PART	DESCRIPTION	QTY.
-12	14222-003-99	. DECAL, Fork Lift Here	2
-14	5225-000-00	. DECAL, Danger Hydrogen Gas	2
-15	05223-000-00	. DECAL, Emergency Down Valve	1
-16	05221-000-00	. DECAL, Battery Fluid	2
-17	03610-000-00	. DECAL, Operating Instruct. Storage	1
-20	61836-000-00	. DECAL, XL-19C/CW	4/6
	61948-000-00	. DECAL, XL-24C/CW	6
-21	61837-000-00	. DECAL, XL-19C	2
-22	61220-000-00	. DECAL, ANSI Requirements	1
-23	03613-002-00	. TUBE, 1-1/2" O.D. x .062 WALL x 11-15/16"	1
-24	11248-004-00	. LOCKNUT, 1/4-20 UNC HEX	2
-25	11252-006-00	. SCREW, 1/4-20 UNC HHC x 3/4"	2
-26	20398-012-00	. CLAMP, Hose	2
-27	03612-000-00	. CAP	2
-29	61999-002-00	. USER MANUAL XL-C Series	1

SECTION VIII

ILLUSTRATED PARTS BREAKDOWN FOR OPTIONS

8-1. INTRODUCTION. This section lists and illustrates the optional assemblies and parts available for XL-C Series machines, as manufactured and/or provided by Up-Right, Inc.

NOTE

Although not shown, foam filled tires are available as an option for the XL-19CW and XL-24C models. Part number 61899-000-00 should be used when ordering these tires.

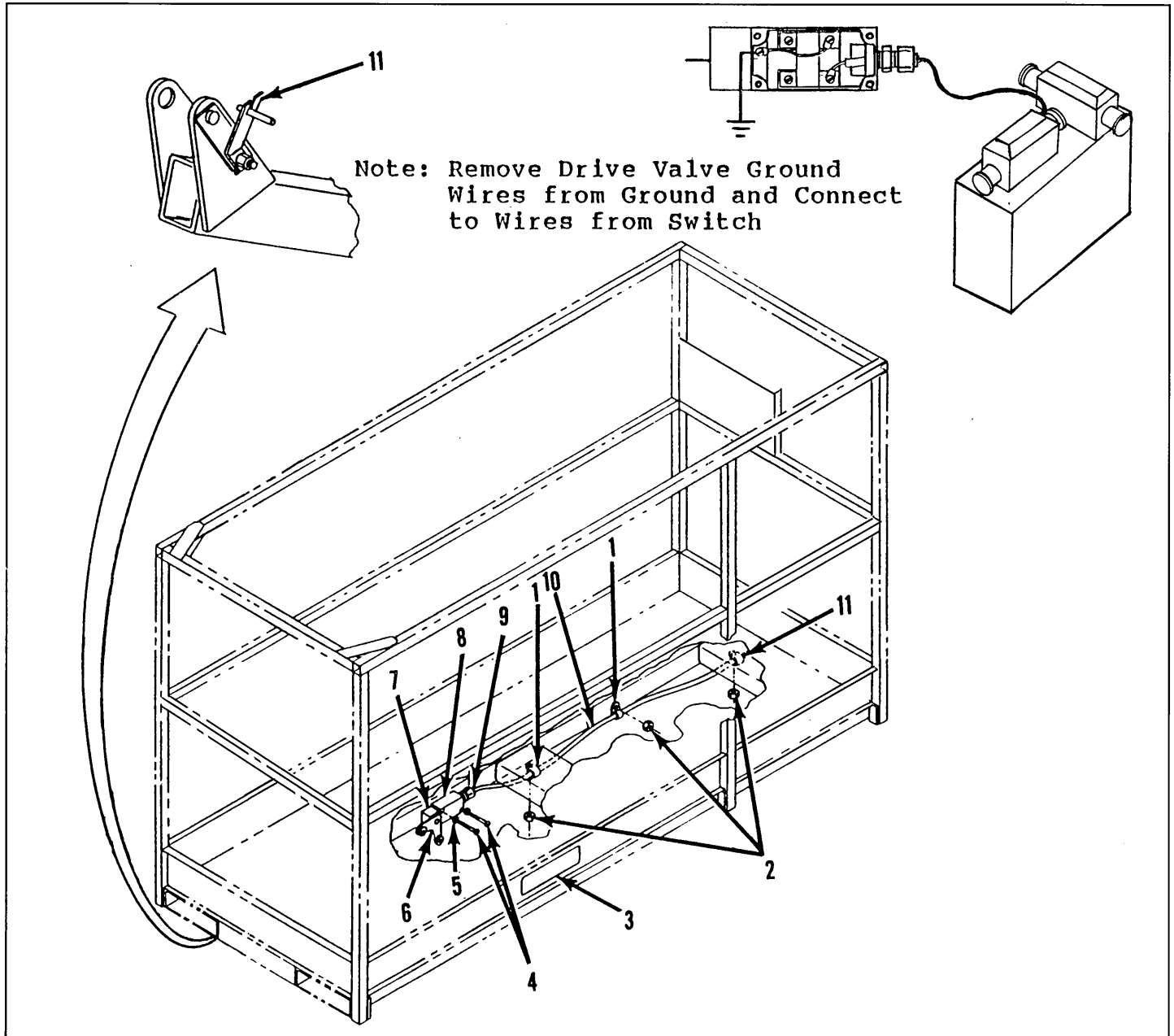

Figure 8-1. 750 LB. Capacity Option, XL-19C

ITEM	PART	DESCRIPTION	QTY.
8-1	61580-000-00	750 LB CAPACITY OPTION, XL-19C	REF
-1	13919-004-00	. CLAMP, Hose	3
-2	11248-004-00	. LOCKNUT, HEX 1/4-20 UNC	3
-3	08442-006-00	. DECAL, 750 LBS	2
-4	11709-012-00	. SCREW, RDHD MACH 10-24 UNC x 1-1/2	2
-5	11238-002-00	. LOCKWASHER, Split 10 DIA.	2
-6	15793-006-00	. LEVER	1

ITEM	PART	DESCRIPTION	QTY.
-7	15793-005-00	. HEAD, Switch	1
-8	15793-001-00	. BODY, Switch	1
	15793-004-00	.. SWITCH	1
-9	29925-000-00	. CONNECTOR, Cable	1
-10	29496-099-00	. CABLE, 2 COND 16 GA	35 FT
-11	61644-000-00	. ACTUATOR WELDMENT	1

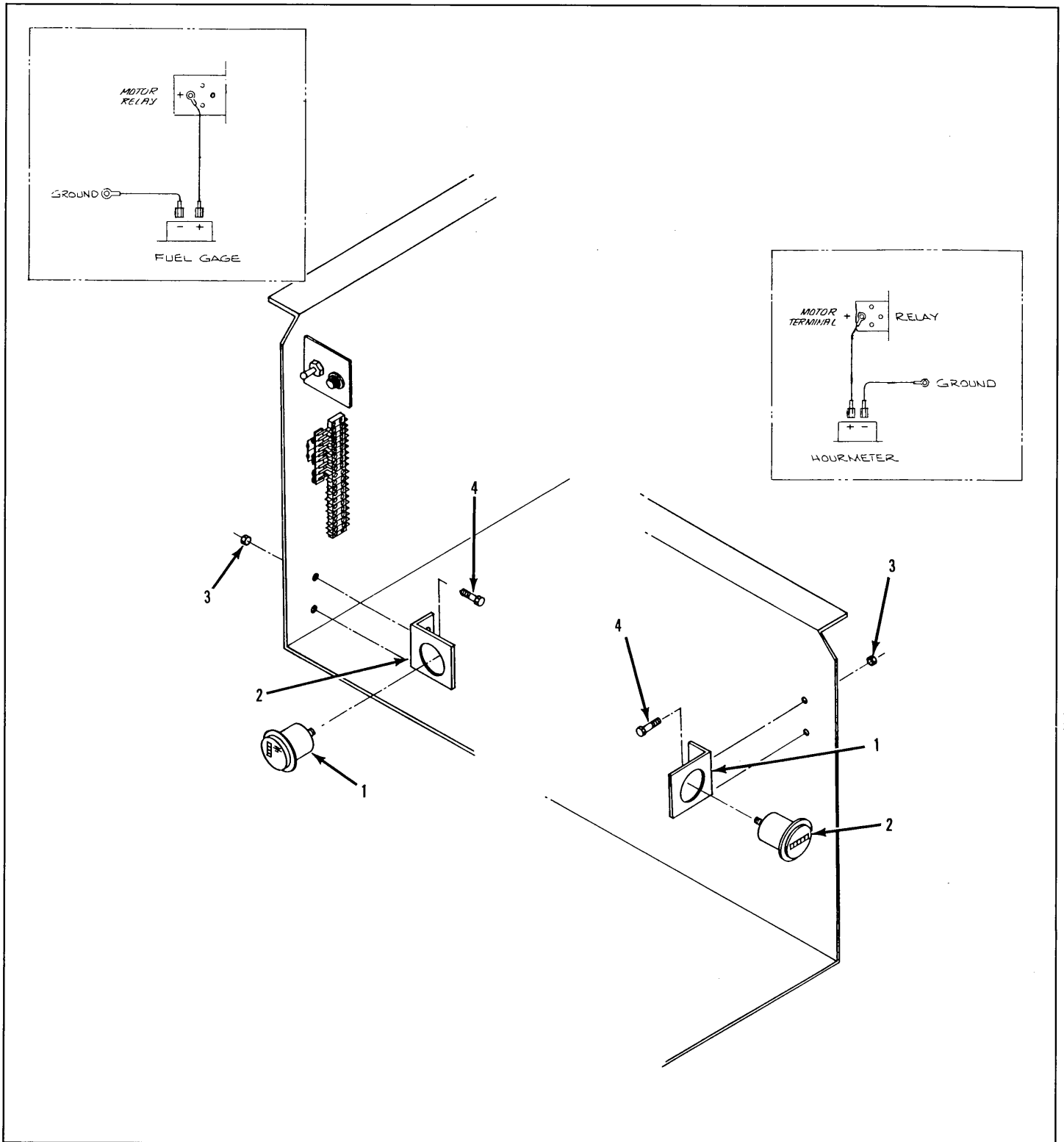

Figure 8-2. Battery Charge Indicator/Hourmeter Option, XL-C Series

ITEM	PART	DESCRIPTION	QTY.
8-2	61576-000-00	BATTERY CHARGER INDICATOR OPTION, XL-C Series	REF
-1	29959-000-00	. INDICATOR/HOURMETER Low Volt.	1
-2	61647-000-00	. BRACKET	1
-3	11248-004-00	. LOCKNUT, HEX 1/4-20 UNC	2
-4	11252-008-00	. SCREW, HHC 1/4-20 UNC x 1	2

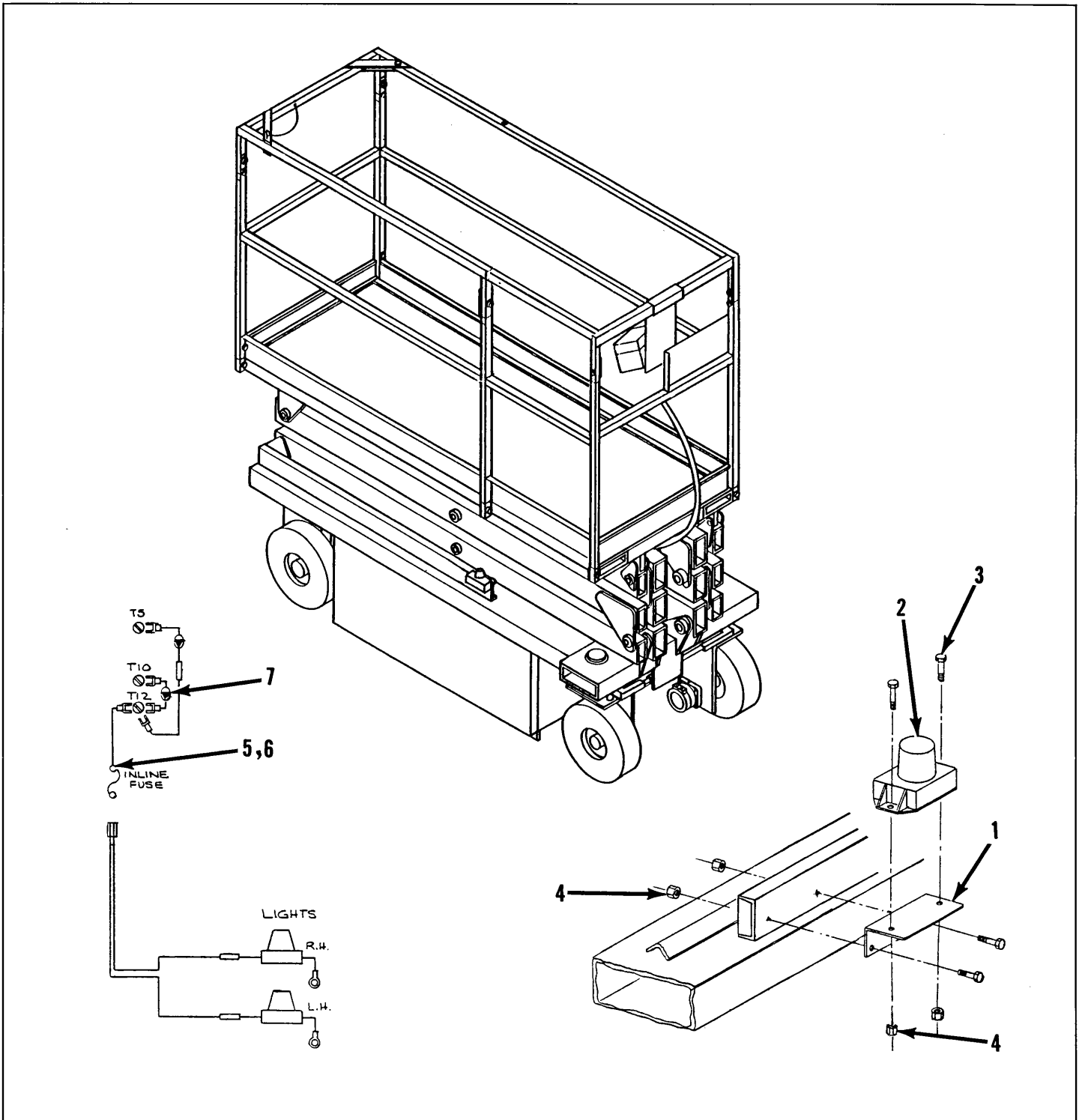

Figure 8-3. Flashing Amber Light Option, XL-C Series

ITEM	PART	DESCRIPTION	QTY.
8-3	61918-000-00	FLASHING AMBER LIGHT OPTION, XL-C Series	REF
-1	63193-000-00	. MOUNT, Light	2
-2	12848-004-00	. LIGHT	2
-3	11826-008-00	. SCREW, RD HD MACH 10-32 UNF x 1	4
-4	11249-003-00	. LOCKNUT, HEX 10-32 UNF	4
-5	29704-002-00	. FUSE, 2 AMP	1
-6	29702-000-00	. HOLDER, FUSE	1
-7	29825-003-00	. DIODE, 3 AMP	2

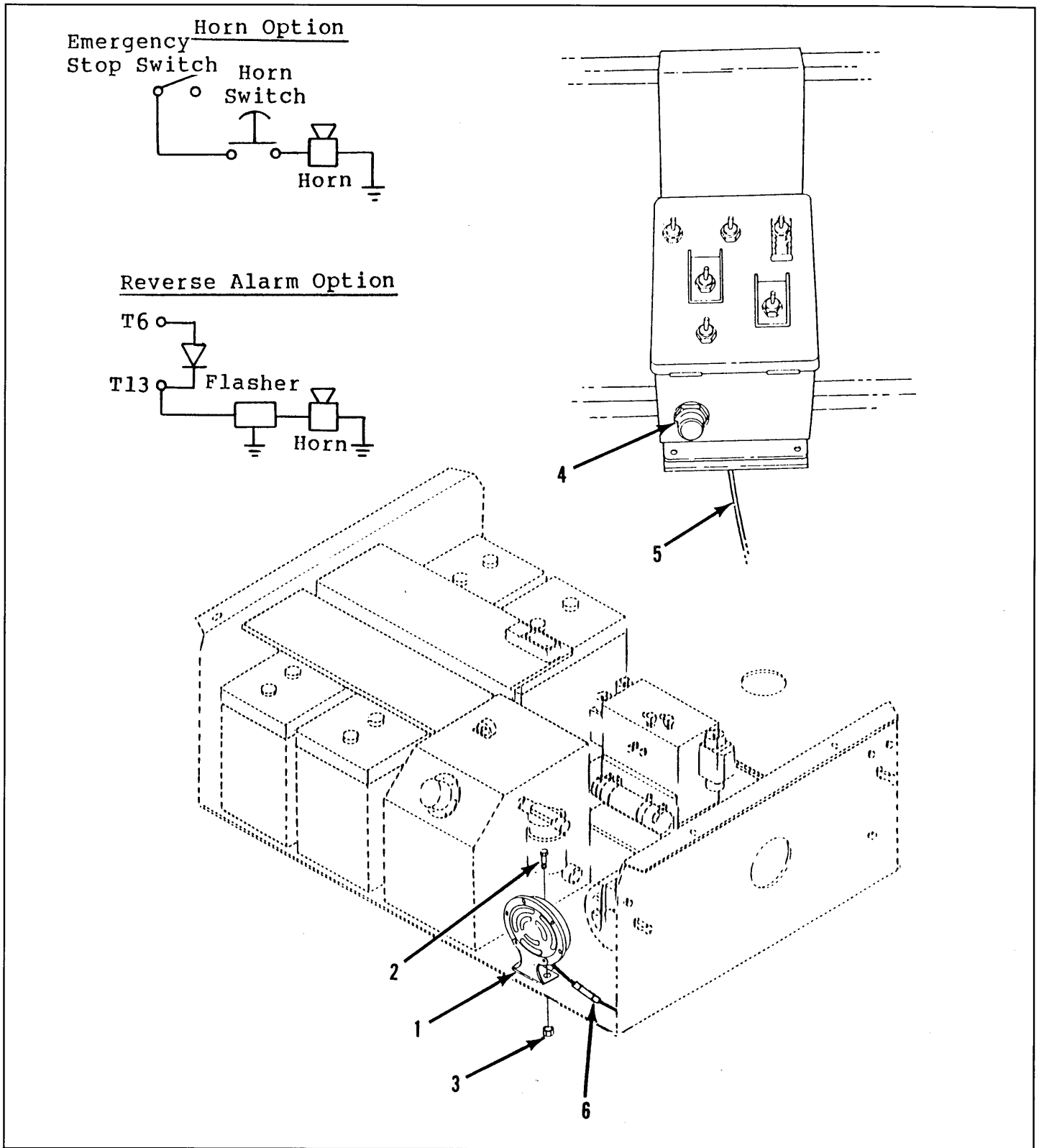

Figure 8-4. Horn and Reverse Alarm Option, XL-C Series

ITEM	PART	DESCRIPTION	QTY.
8-4	61917-000-00	HORN OPTION, XL-C Series	REF
-1	29958-000-00	. HORN	1
-2	11252-008-00	. SCREW, HHC 1/4-20 UNC x 1	2
-3	11248-004-00	. LOCKNUT, HEX 1/4-20 UNC	2
-4	13129-000-00	. PUSHBUTTON	1
-5	29496-099-00	. CABLE, 2 COND. 16 AWG	32 FT

ITEM	PART No.	DISCRIPTION	QTY.
8-4	61587-000-00	REVERSE ALARM OPTION, XL-C Series	REF
-1	29958-000-00	. HORN	1
-2	11254-008-00	. SCREW, HHC 3/8-16 UNC x 1	2
-3	11248-006-00	. LOCKNUT, HEX 3/8-16 UNC	2
-6	08903-000-00	. FLASHER	1

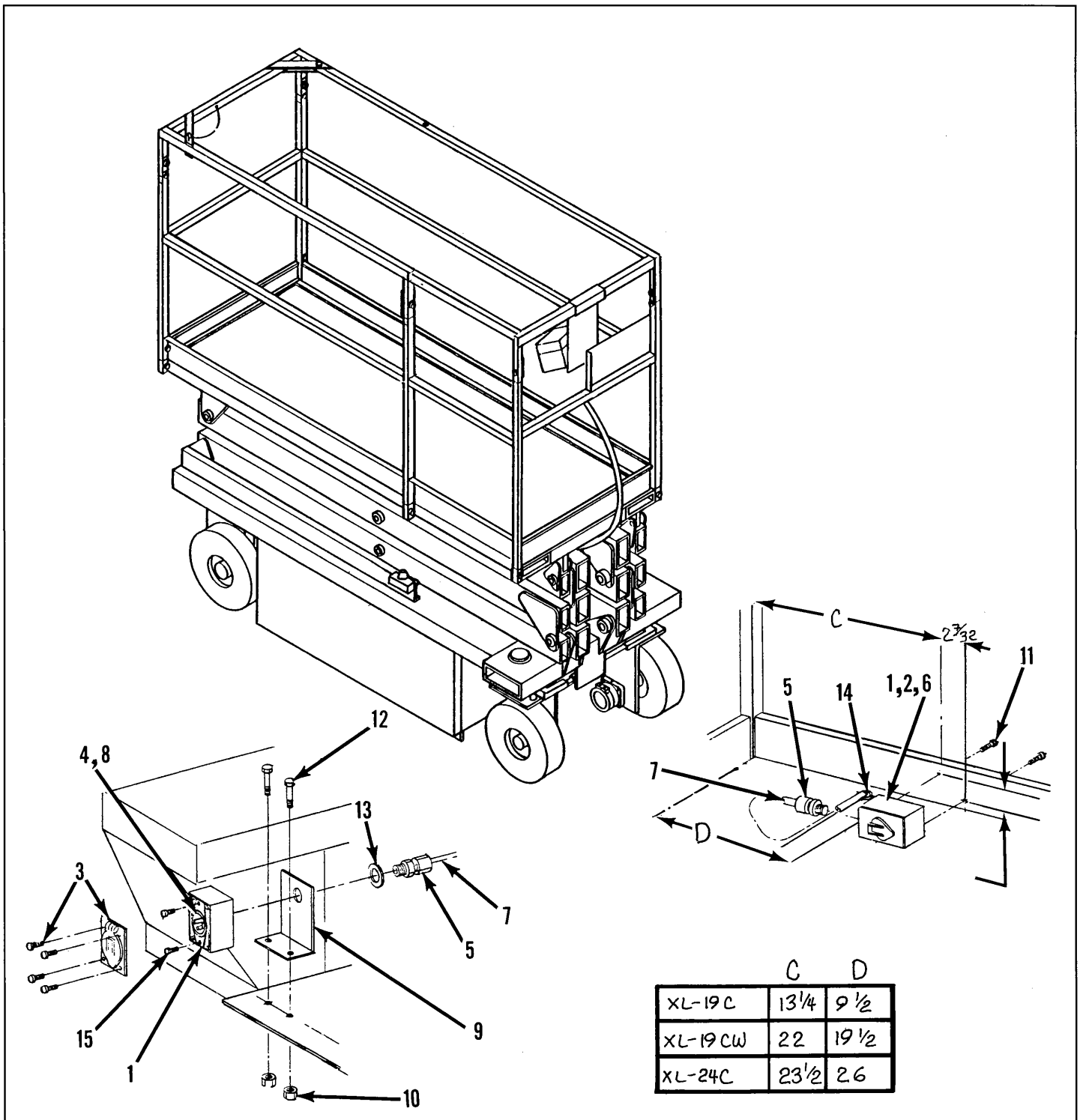

Figure 8-5. Power to Platform Option, XL-C Series

ITEM	PART	DESCRIPTION	QTY.
8-5	61913-000-00	POWER TO PLATFORM OPTION, XL-C Series	REF
-1	15769-000-00	. BOX	2
-2	08942-000-00	. RECEPTACLE	1
-3	29962-000-00	. COVER, Box	1
-4	29961-000-00	. FLANGE, Inlet	1
-5	29925-003-00	. CONNECTOR, Cable	2
-6	26611-002-00	. COVER, Box	1
-7	29495-099-00	. CABLE, 3 COND 14 AWG	41FT.

ITEM	PART	DESCRIPTION	QTY.
-8	15788-000-00	. SUBPLATE	1
-9	61914-000-00	. BRACKET	1
-10	11249-003-00	. NUT, 10-32 UNF	2
-11	11811-006-00	. SCREW, RD HD 6-32 UNC x 1/2	4
-12	11826-008-00	. SCREW, RD HD 10-32 UNF x 1	2
-13	11240-014-00	. WASHER, Flat 7/8 DIA.	1
14	12956-010-00	. GROMMET	2
-15	11715-004-00	. SCREW, RD HD MACH 6-32 UNC x 1/2	2

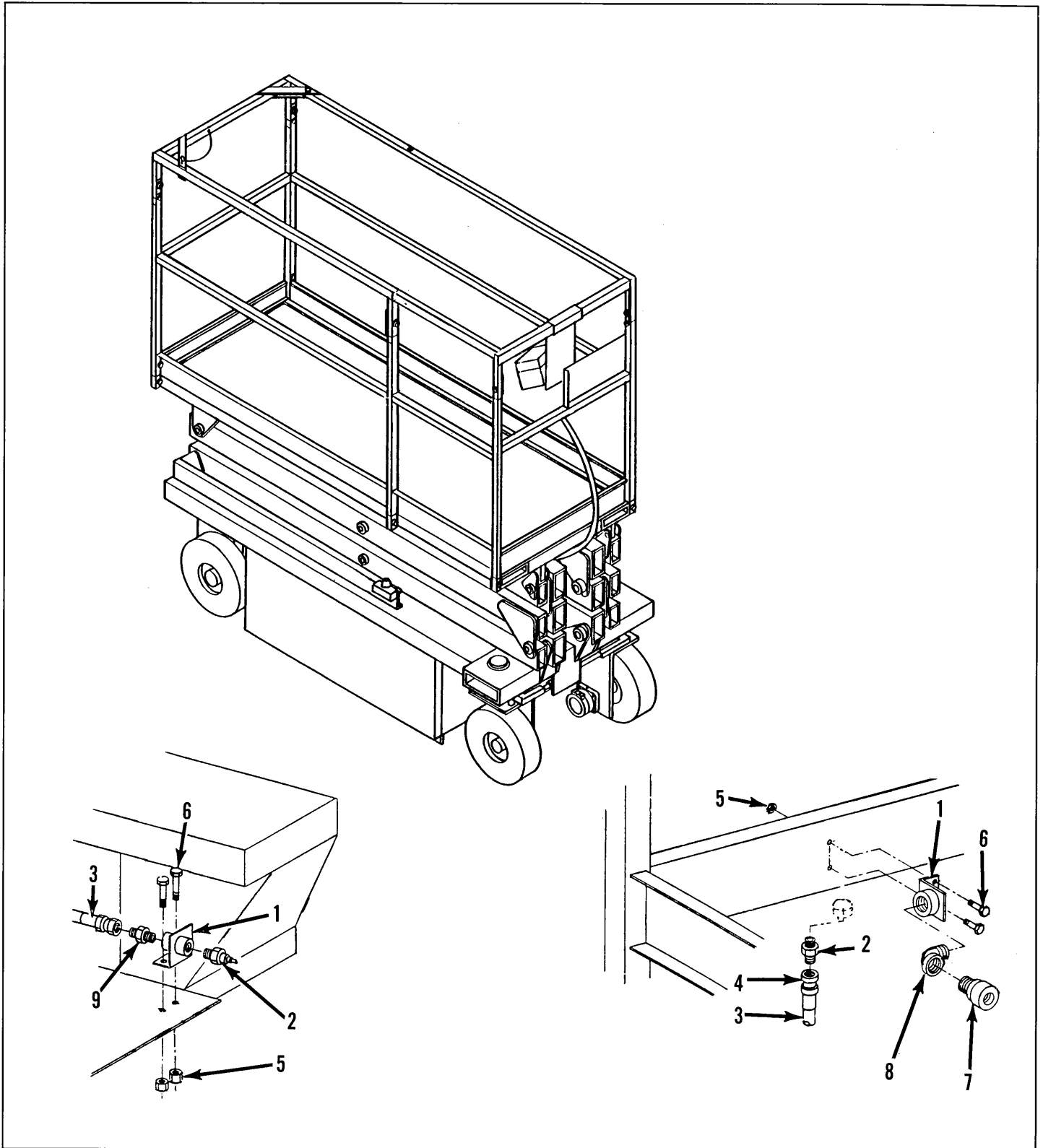

Figure 8-6. Air to Platform Option, XL-C Series

ITEM	PART	DESCRIPTION	QTY.
8-6	61919-000-00	AIR TO PLATFORM OPTION, XL-C Series	REF
-1	63191-000-00	. BRACKET	1
-2	12728-000-00	. COUPLING, Male	1
-3	15770-099-00	. HOSE, 3/8 (XL-19, XL-19CW)	28 FT
		. HOSE, 3/8 (XL-24)	34 FT

ITEM	PART	DESCRIPTION	QTY.
-4	15773-005-00	. END, Hose	2
-5	11249-003-00	. NUT, HEX 10-32 UNF	4
-6	11826-005-00	. SCREW, RD HD 10-23 UNF x 1	4
-7	12729-003-00	. COUPLING, Male	1
-8	11917-007-00	. FITTING, Elbow	1
-9	13487-004-00	. FITTING, Straight	1

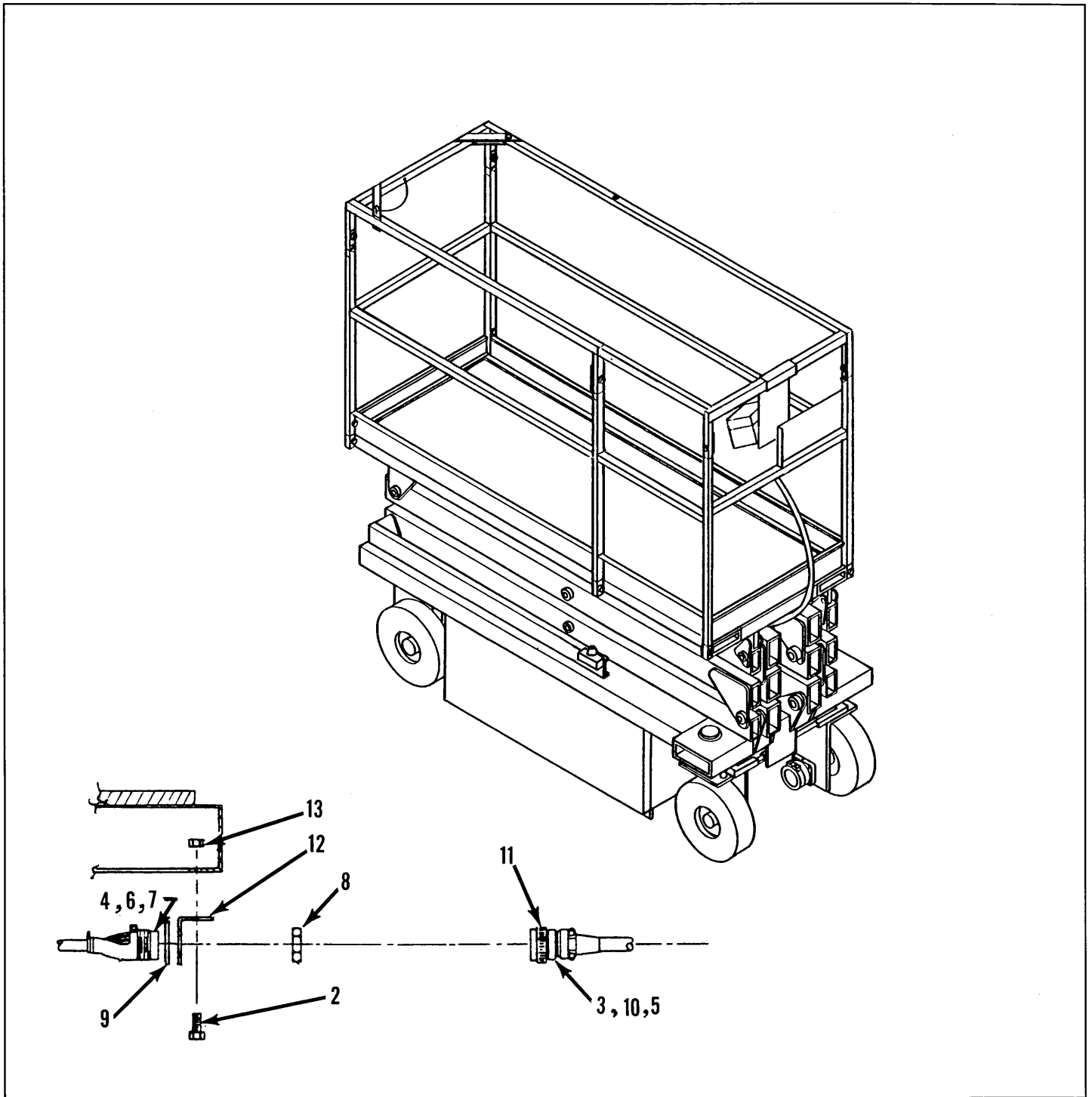

Figure 8-7. Removable Controller Option, XL-C Series

ITEM	PART	DESCRIPTION	QTY.
8-7	61898-000-00	REMOVABLE CONTROLLER OPTION, XL-C Series	REF
-1	61804-000-00	. CONTROLLER	REF
-2	11252-026-00	. SCREW, HHC 1/4-20 UNC x 3-1/4, (XL-19C)	1
	11252-006-00	. SCREW, HHC 1/4-20 UNC x 3/4, (XL-19CW & XL-24)	1
-3	28800-001-00	. PLUG, Connector	1
-4	28800-002-00	. RECEPTICAL	1
-5	28800-004-00	. PIN, Contact	12

ITEM	PART	DESCRIPTION	QTY.
-6	28800-005-00	. SOCKET	12
-7	28800-007-00	. STRAIN RELIEF	1
-8	28800-013-00	. NUT, Panel	1
-9	28800-014-00	. LOCKWASHER	1
-10	28800-015-00	. PLUG, Sealing	11
-11	29904-008-00	. CLAMP, Cable	1
-12	61839-000-00	. BRACKET, Cable	1
-13	11248-004-00	. LOCKNUT, 1/4-20 UNC	2

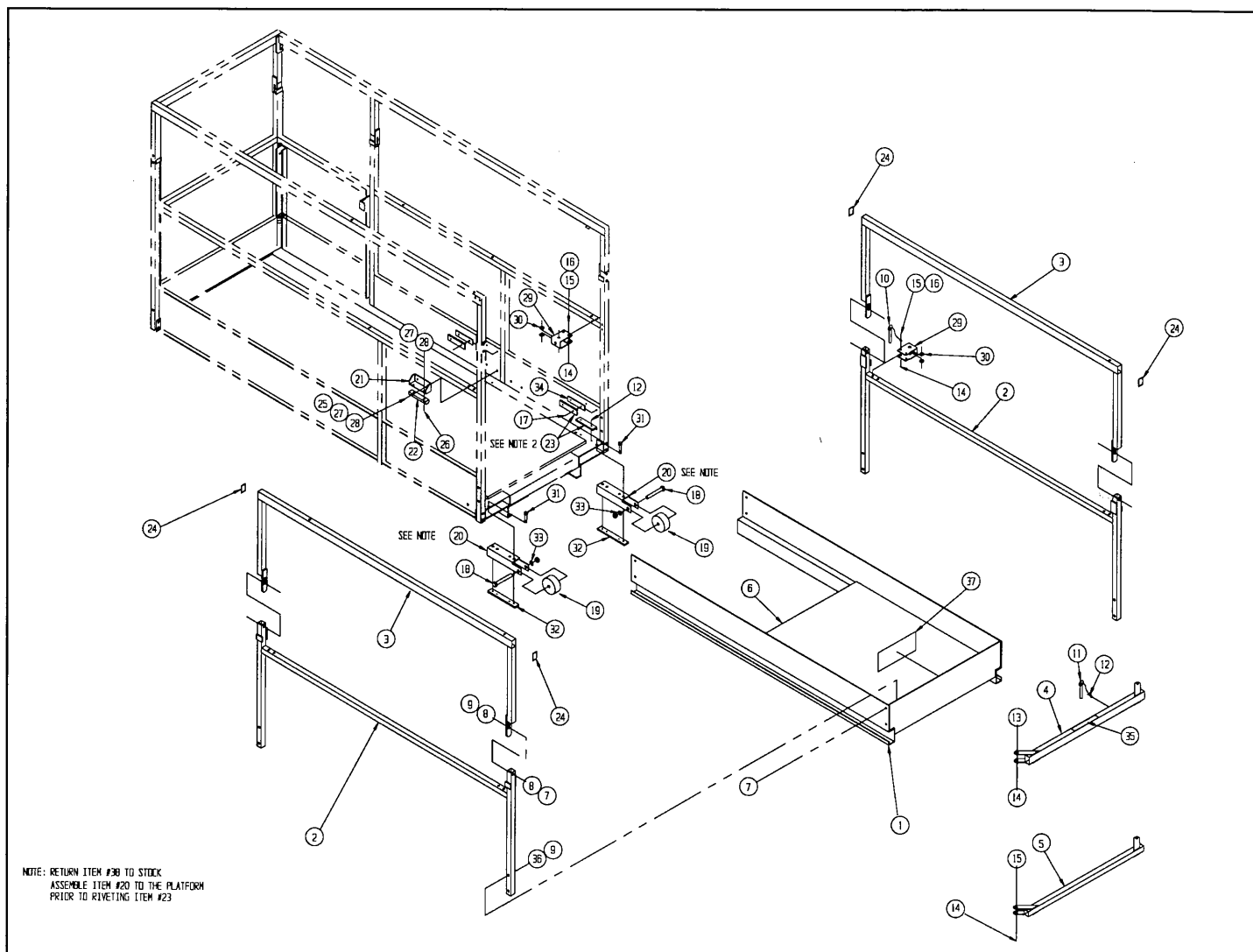

Figure 3-8. Slideout Deck Assembly, XL-19C

ITEM	PART	DESCRIPTION	QTY.
8-8	63575-000-00	SLIDEOUT DECK ASSEMBLY, XL-19C	REF
-1	63478-000-00	. WELDMENT, Deck	1
-2	63722-000-00	. WELDMENT, Rail	2
-3	63723-000-00	. WELDMENT, Rail	2
-4	63482-000-00	. TOP RAIL	1
-5	63483-000-00	. MIDRAIL	1
-6	24611-010-00	. PLYWOOD 1/2 EXT. A/C 23-5/8 x 33-3/4	1
-7	11254-016-00	. SCREW HEX HD CAP 3/8-16 x 2	12
-8	11240-006-00	. WASHER, Flat 3/16	8
-9	11248-006-00	. ESNA NUT, 3/8-16	12
-10	61786-000-00	. LOCKING PIN ASSEMBLY	2
-11	10414-000-00	. LOCKING PIN ASSEMBLY	1
-12	26553-004-00	. RIVET, Pop 3/16 x 3/8 Grip	5
-13	11253-022-00	. SCREW HEX HD CAP 5/16-18 x 2-3/4	1
-14	11248-005-00	. ESNA NUT 5/16-18	11
-15	11253-016-00	. SCREW HEX HD CAP 5/16-18 x 2	10
-16	11240-005-00	. WASHER Flat 5/16	16
-17	26553-009-00	. RIVET, Pop 3/16 x 5/8 GRIP	8
-18	63990-001-00	. AXLE	2

ITEM	PART	DESCRIPTION	QTY.
-19	63989-001-00	. WHEEL	2
-20	63490-000-00	. BRACKET, Wheel Mounting	2
-21	63726-000-00	. BRACKET, Slide	2
-22	63727-000-00	. BLOCK, Slide	2
-23	63728-000-00	. BLOCK, Slide	6
-24	63926-002-00	. PLUG, Tube	4
-25	11252-006-00	. SCREW HEX HD CAP 1/4-20 x 3/4	4
-26	11253-008-00	. SCREW HEX HD CAP 1/4-20 x 1	4
-27	11248-004-00	. ESNA NUT 1/4-20	8
-28	11240-004-00	. WASHER Flat 1/4	8
-29	63729-000-00	. GUARDRAIL CLIP	4
-30	63730-000-00	. SLIDE BUTTON	12
-31	11254-008-00	. SCREW HEX HD CAP 3/8-16 x 1	4
-32	63578-000-00	. BLOCK, Retaining	2
-33	11240-008-00	. WASHER, Flat 1/2	2
-34	63571-000-00	. SPACER	4
-35	61787-000-00	. DECAL, Danger	1
-36	11254-014-00	. SCREW HEX HD CAP 3/8-16 x 1-3/4	8
-37	05652-000-00	. DECAL, MAX. LOAD 250 LB	1

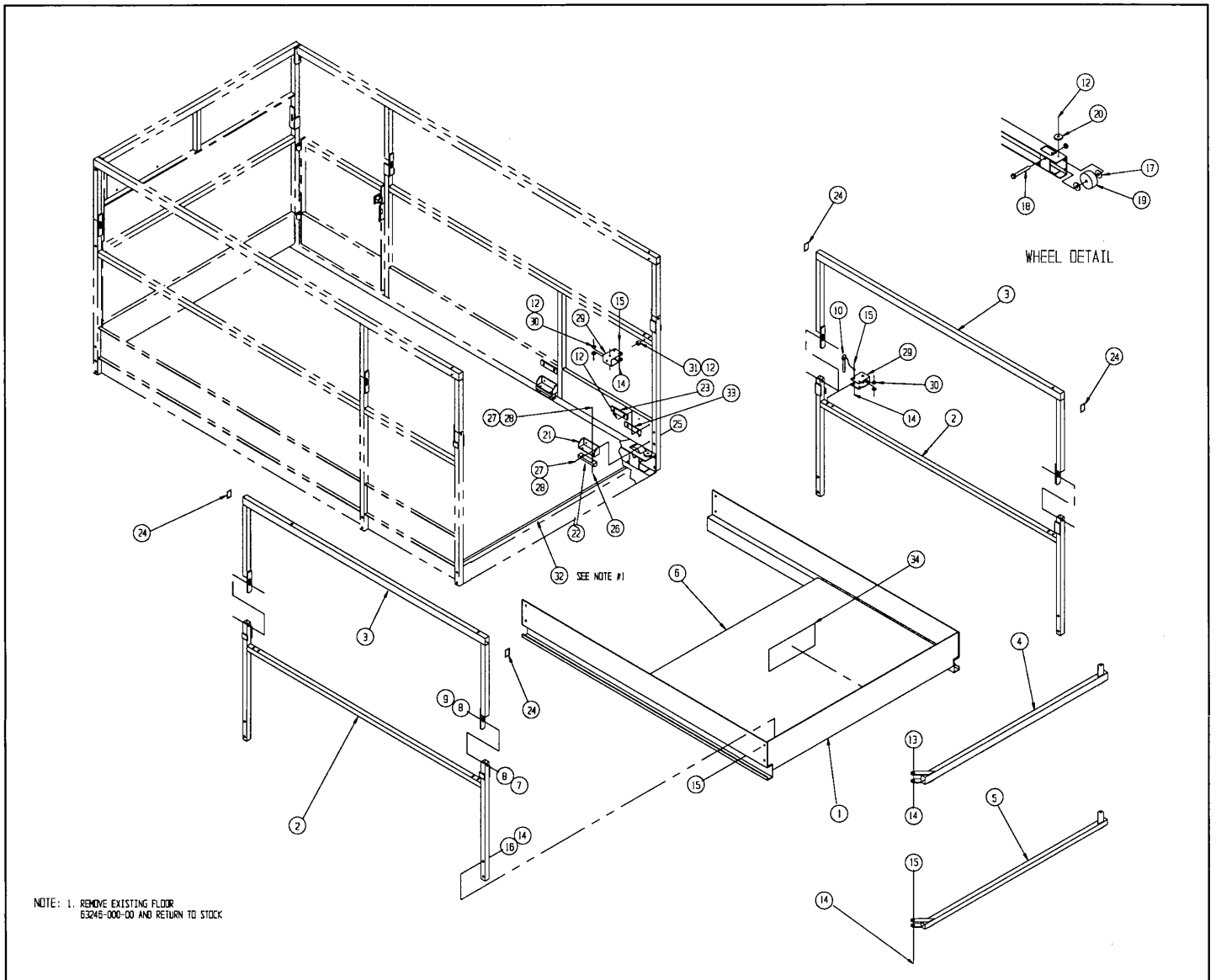

Figure 8-9. Slideout Deck Assembly, XL-19CW, XL-24C and XL-24CW

ITEM	PART	DESCRIPTION	QTY.
8-9	63720-000-00	SLIDEOUT DECK ASSEMBLY, XL-19CW, XL-24C and XL-24CW	REF
-1	63721-000-00	. WELDMENT, Deck	1
-2	63722-000-00	. WELDMENT, Rail	2
-3	63723-000-00	. WELDMENT, Rail	2
-4	63724-000-00	. TOP RAIL	1
-5	63725-000-00	. MIDRAIL	1
-6	24611-009-00	. PLYWOOD 1/2 EXT. A/C 44-1/4 x 34	1
-7	11254-016-00	. SCREW HEX HD CAP 3/8-16 x 2	12
-8	11240-006-00	. WASHER, Flat 3/8	12
-9	11248-006-00	. ESNA NUT, 3/8-16	12
-10	61786-000-00	. LOCKING PIN ASSEMBLY	2
-11	11240-003-00	. WASHER, Flat 3/16	2
-12	26553-004-00	. RIVET, Pop 3/16 x 3/8 Grip	16
-13	11253-022-00	. SCREW HEX HD CAP 5/16-18 x 2-3/4	1
-14	11248-005-00	. ESNA NUT 5/16-18	10
-15	11253-014-00	. SCREW HEX HD CAP 5/16-18 x 2	9
-16	11240-006-00	. WASHER Flat 5/16	10

ITEM	PART	DESCRIPTION	QTY.
-17	63991-001-00	. WASHER, Thrust	4
-18	63990-001-00	. AXLE	2
-19	63989-001-00	. WHEEL	2
-20	63771-000-00	. BEARING, Slide	2
-21	63726-000-00	. BRACKET, Slide	4
-22	63727-000-00	. BLOCK, Slide	4
-23	63728-000-00	. BLOCK, Slide	6
-24	63926-002-00	. PLUG, Tube	4
-25	11252-006-00	. SCREW HEX HD CAP 1/4-20 x 3/4	8
-26	11253-008-00	. SCREW SOCKET HD CAP 1/4-20 x 1	8
-27	11248-004-00	. ESNA NUT 1/4-20	16
-28	11240-004-00	. WASHER Flat 1/4	16
-29	63729-000-00	. GUARDRAIL CLIP	4
-30	63730-000-00	. SLIDE BUTTON	12
-31	63731-000-00	. SLIDE BUTTON	2
-32	63246-001-00	. PLATFORM FLOOR (See Note #1)	1
-33	63571-000-00	. SPACER	4
-34	05652-000-00	. DECAL, MAX. LOAD 250 LBS	1

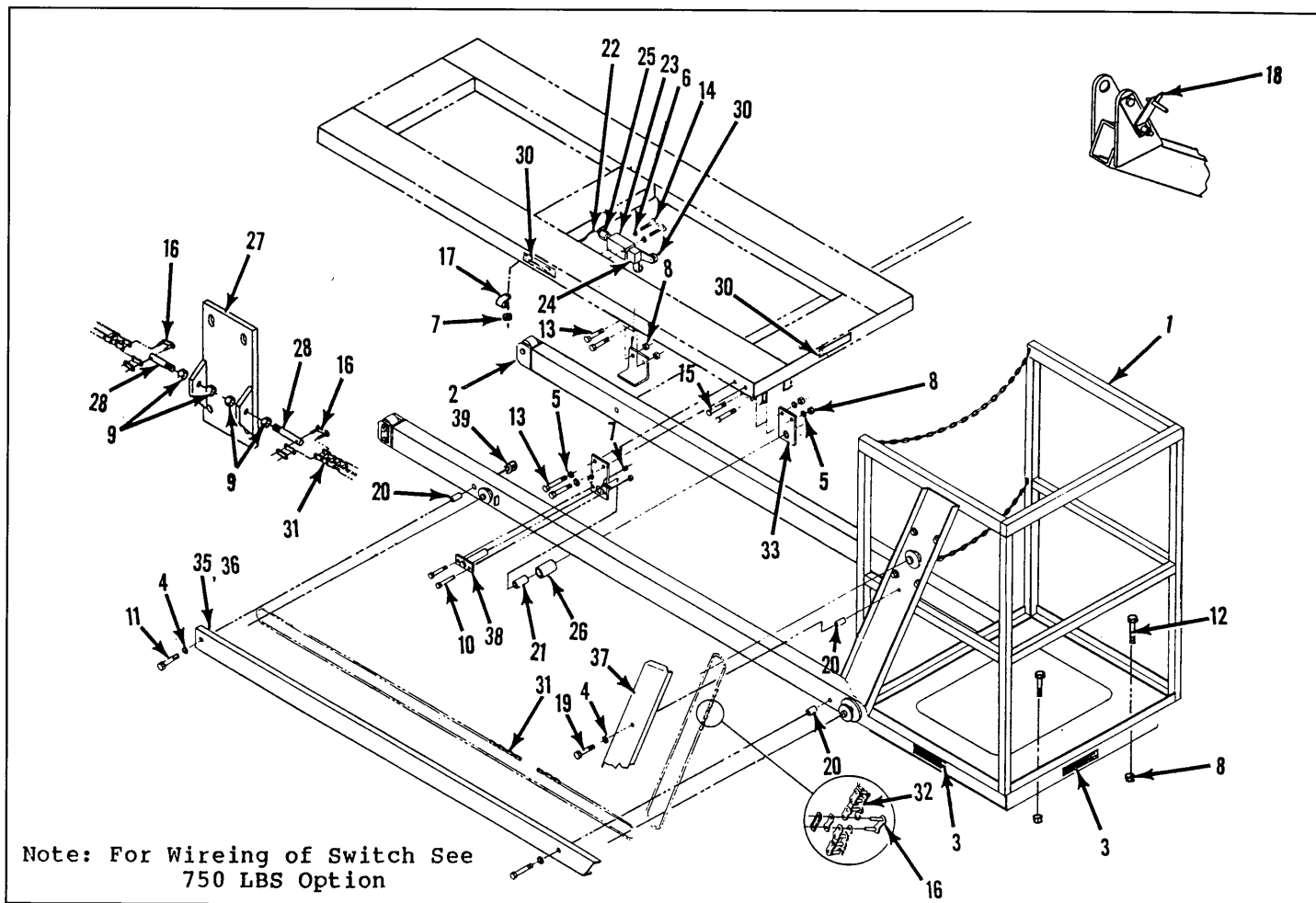

Figure 8-10. Cantilever Cage Option Installation, XL-19C

ITEM	PART	DESCRIPTION	QTY.
8-10	61582-000-00	CANTILEVER CAGE OPTION INSTALLATION, XL-19C	REF
-1	61601-000-00	. CAGE ASSEMBLY (See Figure 8-15)	1
-2	61602-000-00	. ROLLING FRAME ASSEMBLY (See Figure 8-17)	1
-3	05652-000-00	. DECAL, Max Load 250LBS	3
-4	11240-004-00	. WASHER, Flat 1/4 DIA.	8
-5	11240-006-00	. WASHER, Flat 3/8 DIA.	8
-6	11238-002-00	. LOCKWASHER, Split 10 DIA.	2
-7	11248-004-00	. LOCKNUT, HEX 1/4-20 UNC	13
-8	11248-006-00	. LOCKNUT, HEX 3/8-16 UNC	12
-9	11250-004-00	. NUT, HEX 1/4-20 UNC	8
-10	11252-008-00	. SCREW, HHC 1/4-20 UNC	4
-11	11252-030-00	. SCREW, HHC 1/4-20 UNC x 3-3/4	4
-12	11254-008-00	. SCREW, HHC 3/8-16 UNC x 1	4
-13	11254-010-00	. SCREW, HHC 3/8-16 UNC x 1-1/4	8
-14	11709-012-00	. SCREW, RDHDMACH 10-24 UNC x 1-1/2	2
-15	11741-010-00	. SCREW, Flat HD SOC 3/8-16 UNC 4 x 1-1/4	4
-16	11884-003-00	. LINK, Connecting	5
-17	13919-004-00	. CLAMP, Hose	3
-18	61644-000-00	. ACTUATOR WELDMENT	1

ITEM	PART	DESCRIPTION	QTY.
-19	11252-016-00	. SCREW, HHC 1/4-20 UNC x 2	2
-20	17404-002-00	. SPACER	5
-21	27931-010-00	. BEARING	4
-22	29496-099-00	. CABLE, 2 COND 16 AWG	32 FT
-23	15793-001-00	. BODY, Switch	1
	15793-004-00	. SWITCH	1
-24	15793-005-00	. HEAD, Switch	1
-25	29925-000-00	. CONNECTOR, Cable	1
-26	61617-000-00	. ROLLER	2
-27	61318-000-00	. BRACKET WELDMENT	2
-28	61322-000-00	. SCREW, Chain Adjustment	4
-29	61355-000-00	. SAFETY WALK	1
-30	15793-006-00	. LEVER	1
-31	05641-015-00	. CHAIN x 285 Pitches	2
-32	05641-012-00	. CHAIN x 195 Pitches	1
-33	61609-000-00	. BRACKET	2
-34	61610-000-00	. RETAINER	2
-35	61611-000-00	. GUARD, LH	1
-36	61612-000-00	. GUARD, RH	1
-37	61613-000-00	. GUARD	1
-38	61615-000-00	. PIN	2
-39	11246-004-00	. LOCKNUT, HEX Thin 1/4-20 UNC	4

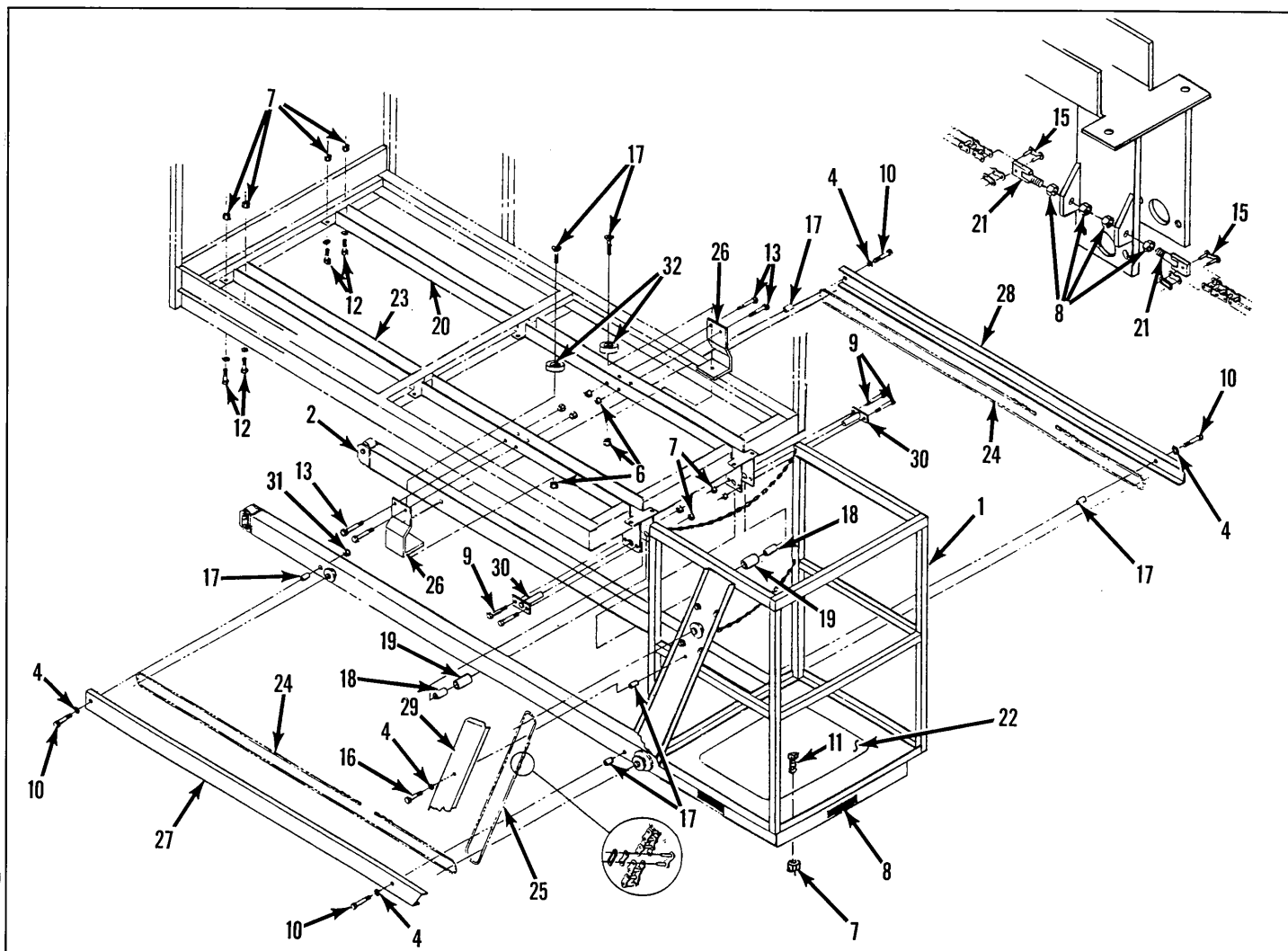

Figure 8-11. Cantilever Cage Option Installation, XL-19CW

ITEM	PART	DESCRIPTION	QTY.
8-11	61951-000-00	CANTILEVER CAGE OPTION INSTALLATION, XL-19CW	REF
-1	61921-000-00	. CAGE ASSEMBLY (See Figure 8-13)	1
-2	61922-000-00	. ROLLING FRAME ASSEMBLY (See Figure 8-15)	1
-3	05652-000-00	. DECAL, Max Load 250 LBS	3
-4	11240-004-00	. WASHER, Flat 1/4 DIA.	10
-5	11240-006-00	. WASHER, Flat 3/8 DIA.	12
-6	11248-004-00	. LOCKNUT, HEX 1/4-20 UNC	4
-7	11248-006-00	. LOCKNUT, HEX 3/8-16 UNC	24
-8	11250-004-00	. NUT, HEX 1/4-20 UNC	8
-9	11252-008-00	. SCREW, HHC 1/4-20 UNC	4
-10	11252-030-00	. SCREW, HHC 1/4-20 UNC x 3-3/4	4
-11	11254-008-00	. SCREW, HHC 3/8-16 UNC x 1	4
-12	11254-010-00	. SCREW, HHC 3/8-16 UNC x 1-1/4	10
-13	11254-032-00	. SCREW, HHC 3/8-16 UNC x 4	4
-14	11828-008-00	. SCREW, Flat HD SOC 1/4-20 UNC x 1	2

ITEM	PART	DESCRIPTION	QTY.
-15	11884-003-00	. LINK, Connecting	5
-16	11252-016-00	. SCREW, HHC 1/4-20 UNC x 2	2
-17	17404-002-00	. SPACER	5
-18	27931-010-00	. BEARING	4
-19	61617-000-00	. ROLLER	2
-20	61964-000-00	. TRACK CHANNEL, RH	1
-21	61322-000-00	. SCREW, Chain Adjustment	4
-22	61355-000-00	. SAFETY WALK	1
-23	61980-000-00	. TRACK CHANNEL, LH	1
-24	05641-011-00	. CHAIN x 291 Pitches	2
-25	05641-012-00	. CHAIN x 195 Pitches	1
-26	61930-000-00	. GUIDE, Cantilever Cage	2
-28	61612-000-00	. GUARD, RH	1
-29	61613-000-00	. GUARD	1
-30	61615-000-00	. PIN	2
-31	11246-004-00	. NUT, ESNA 1/4-20 Thin	4
-32	60643-000-00	. BEARING, Round Slide	2

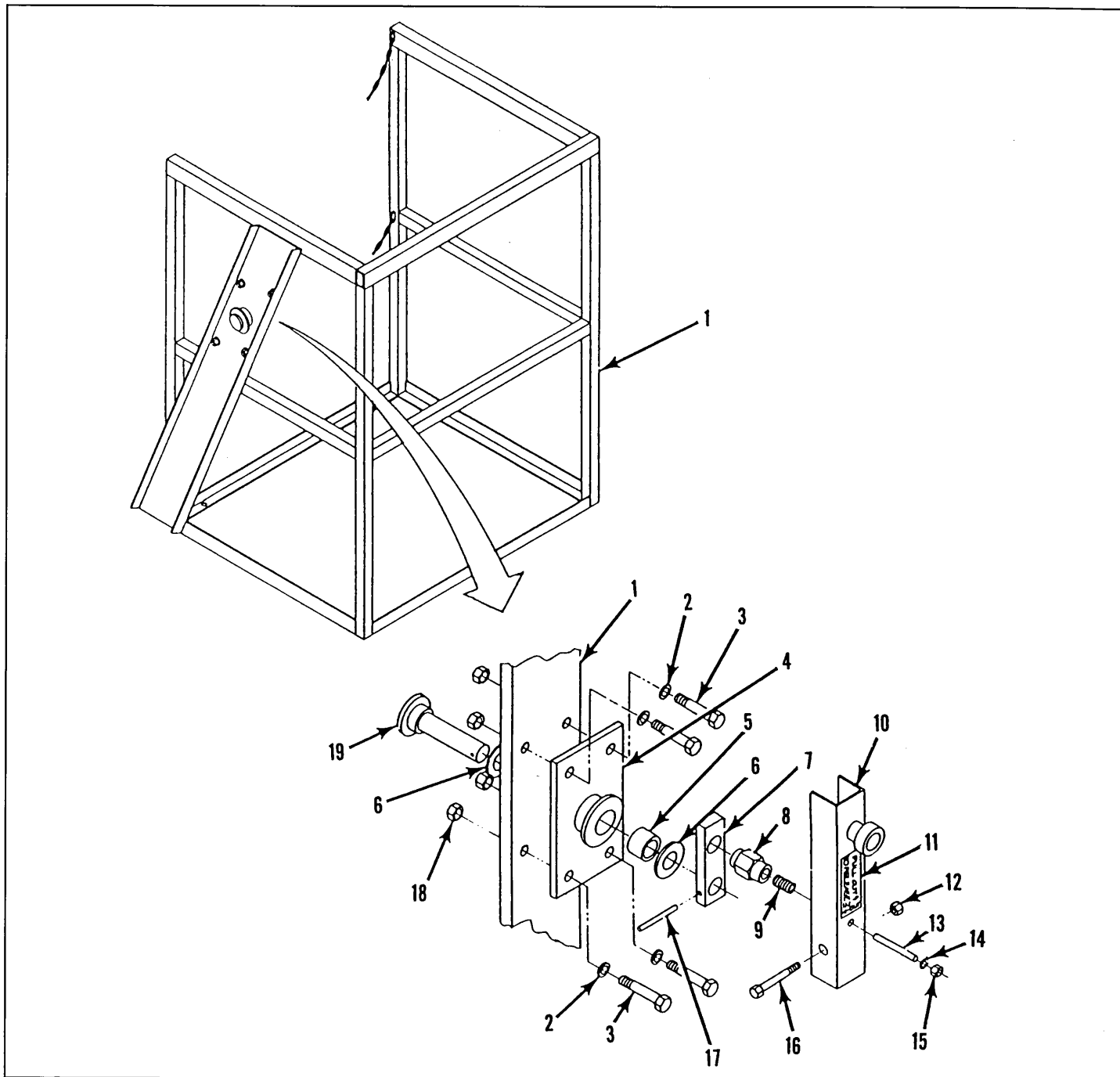

Figure 8-12. Cage Assembly, Canilever Cage Option, XL-19C

ITEM	PART	DESCRIPTION	QTY.
8-12	61601-000-00	CAGE ASSEMBLY, Cantilever Cage Option, XL-19C (See Figure 8-11 for NHA)	REF
-1	61603-000-00	. CAGE WELDMENT	1
-2	11240-006-00	. WASHER, Flat 3/8 DIA	4
-3	11254-008-00	. SCREW, HHC 3/8-16 UNC GR5 x 1	4
-4	61316-000-00	. PLATE WELDMENT	1
-5	27931-018-00	. BEARING	1
-6	06452-000-00	. BEARING, Thrust	2
-7	05346-000-00	. ARM	1
-8	03443-001-00	. HOUSING	1

ITEM	PART	DESCRIPTION	QTY.
-9	05376-000-00	. SPRING	1
-10	61353-000-00	. HANDLE	1
-11	61352-000-00	. DECAL, Pull Out	1
-12	11248-005-00	. LOCKNUT, HEX 5/16-18 UNC	1
-13	05373-000-00	. PIN, Retaining	1
-14	11240-004-00	. WASHER, Flat 1/4 DIA.	1
-15	11246-004-00	. LOCKNUT, HEX 1/4-20 UNC	1
-16	11253-014-00	. SCREW, HHC 5/16-18 UNC x 1-3/4	1
-17	11735-020-00	. PIN, Roll	1
-18	11248-006-00	. LOCKNUT, HEX 3/8-16 UNC	4
-19	61307-000-00	. SHAFT	1

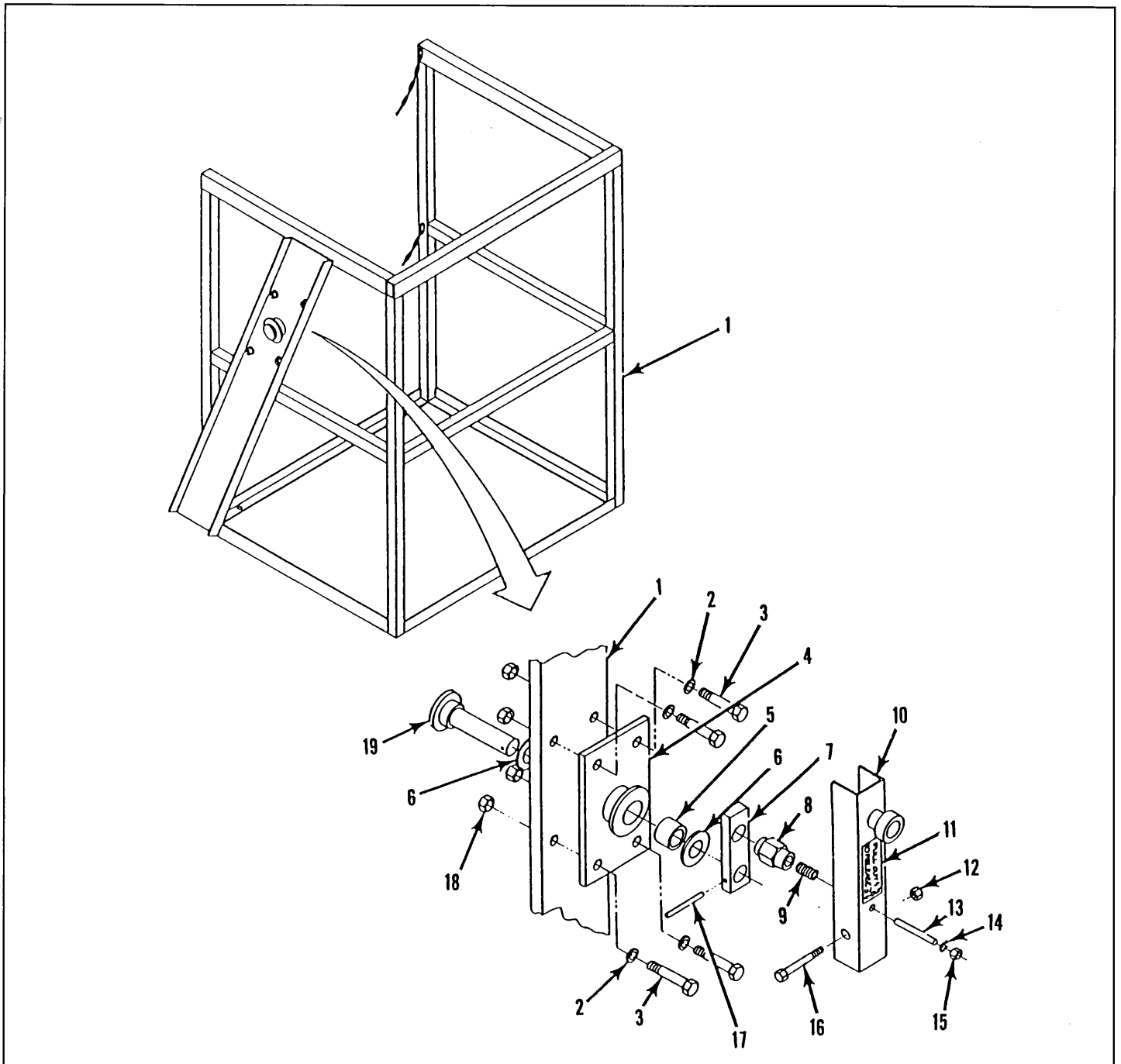

Figure 8-13. Cage Assembly, Cantilever Cage Option, XL-19CW and XL-24C

ITEM	PART	DESCRIPTION	QTY.
8-13	61921-000-00	CAGE ASSEMBLY, Cantilever Cage Option, XL-19CW & XL-24C (See Figure 8-11 for NHA)	REF
-1	61923-000-00	. CAGE WELDMENT	1
-2	11240-006-00	. WASHER, Flat 3/8 DIA.	4
-3	11254-008-00	. SCREW, HHC 3/8-16 UNC GR5 x 1	4
-4	61316-000-00	. PLATE WELDMENT	1
-5	27931-018-00	. BEARING	1
-6	06452-000-00	. BEARING, Thrust	2
-7	05346-000-00	. ARM	1
-8	03443-001-00	. HOUSING	1

ITEM	PART	DESCRIPTION	QTY.
-9	05376-000-00	. SPRING	1
-10	61353-000-00	. HANDLE	1
-11	61352-000-00	. DECAL, Pull Out	1
-12	11248-005-00	. LOCKNUT, HEX 5/16-18 UNC	1
-13	05373-000-00	. PIN, Retaining	1
-14	11240-004-00	. WASHER, Flat 1/4 DIA.	1
-15	11246-004-00	. LOCKNUT, HEX 1/4-20 UNC	1
-16	11253-012-00	. SCREW, HHC 5/16-18 UNC GR5 x 1-1/2	1
-17	11735-020-00	. PIN, Roll	1
-18	11248-006-00	. LOCKNUT, HEX 3/8-16 UNC	4
-19	61307-000-00	. SHAFT	1

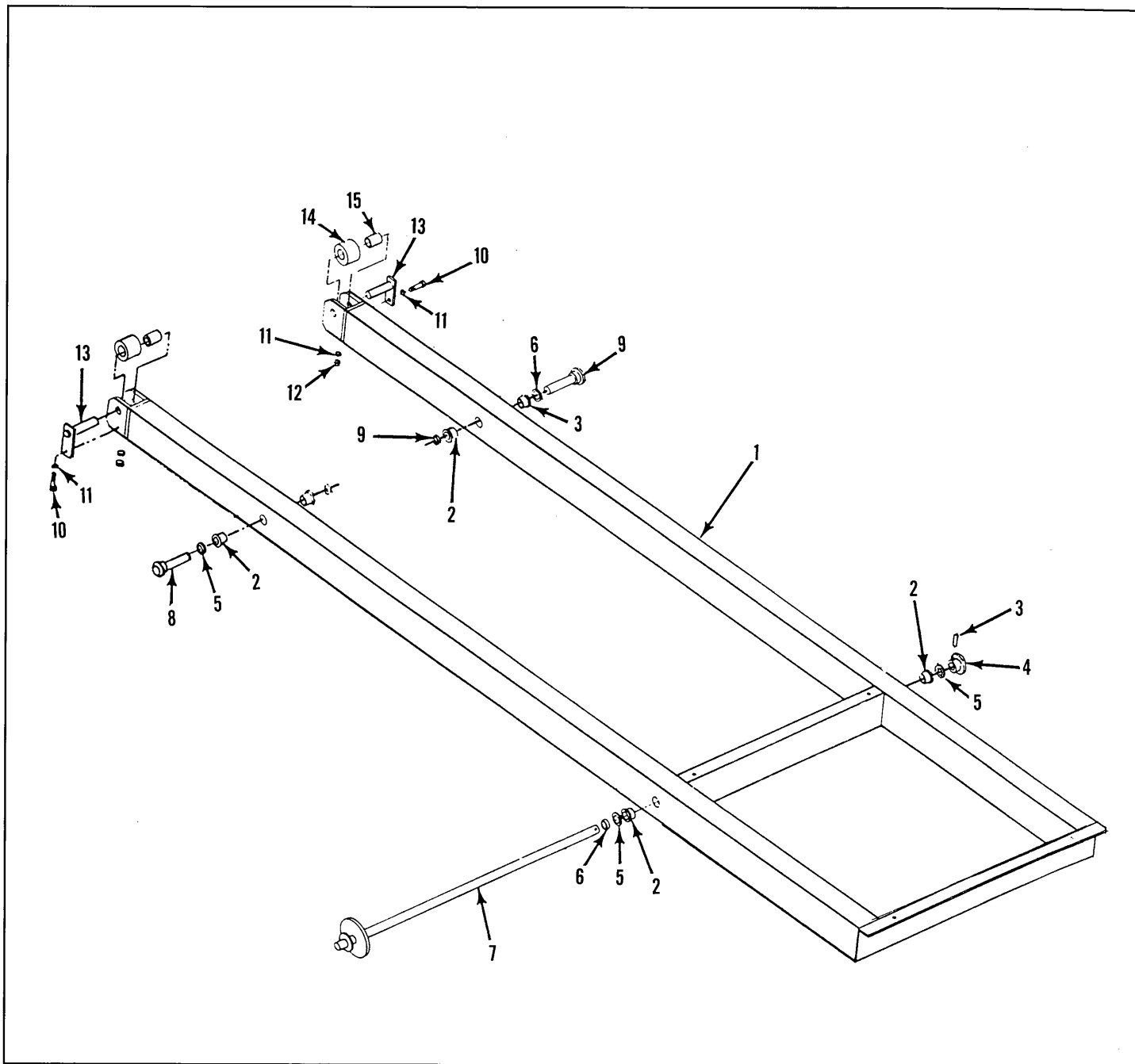

Figure 8-14. Rolling Frame Assembly, Cantilever Cage Option, XL-19C

ITEM	PART	DESCRIPTION	QTY.
8-14	61602-000-00	ROLLING FRAME ASSEMBLY, Cantilever Cage Option, XL-19C (See Figure 8-10 for NHA)	REF
-1	61604-000-00	. ROLLING FRAME	1
-2	00173-000-00	. BEARING	6
-3	11735-020-00	. PIN, Roll	1
-4	61359-000-00	. SPROCKET	1
-5	06452-000-00	. BEARING, Thrust	4
-6	61340-000-00	. SPACER	1

ITEM	PART	DESCRIPTION	QTY.
-7	61313-000-00	. SHAFT WELDMENT	1
-8	61310-000-00	. SHAFT WELDMENT	2
-9	11764-012-00	. RING, Retaining	2
-10	11252-008-00	. SCREW, HHC 1/4-20 UNC GR5 x 1	2
-11	11240-004-00	. WASHER, Flat 1/4 DIA.	4
-12	11248-004-00	. LOCKNUT, HEX 1/4-20 UNC	2
-13	61304-000-00	. PIN WELDMENT	2
-14	61336-000-00	. ROLLER	2
-15	27931-010-00	. BEARING	2

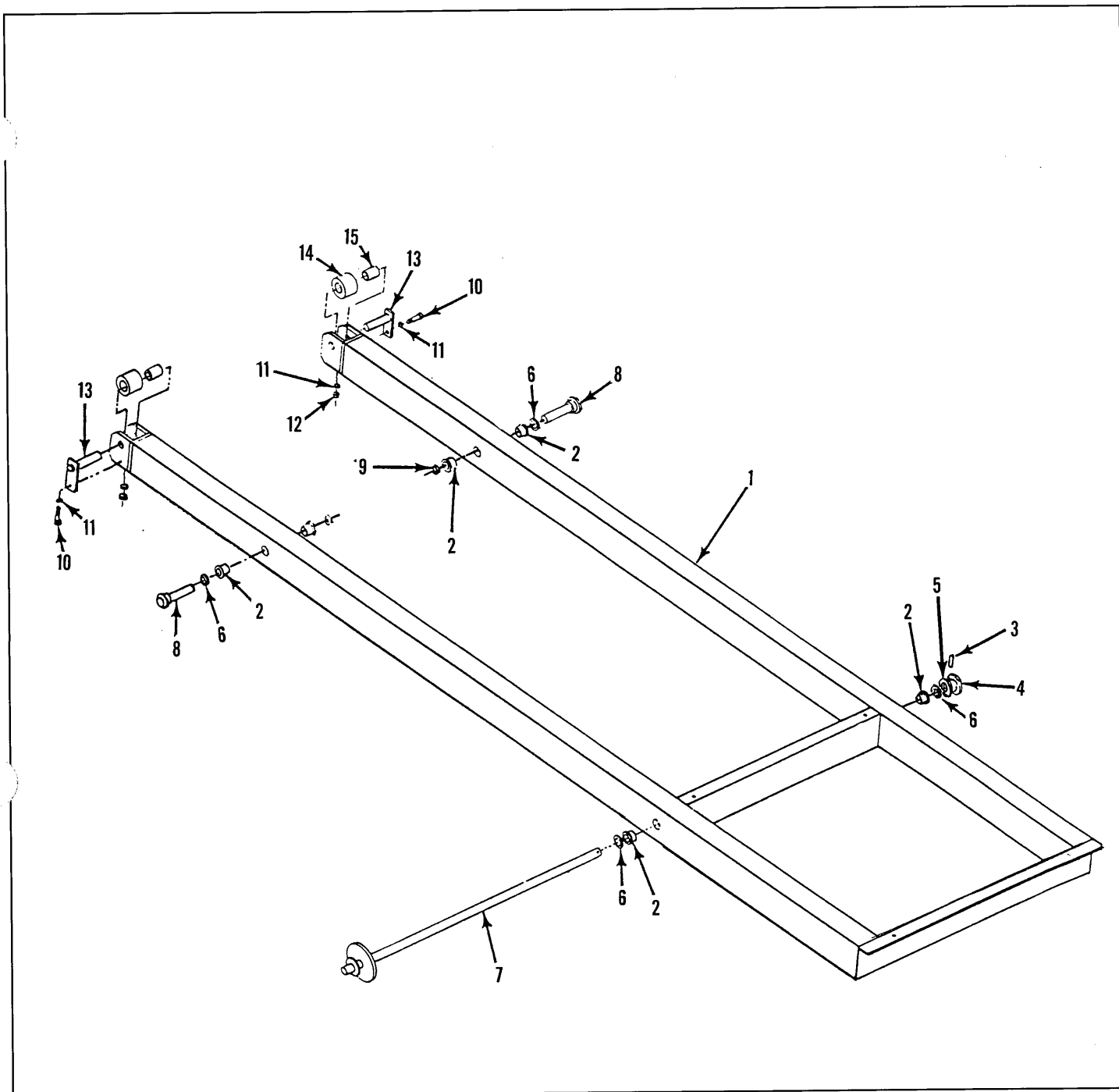

Figure 8-15. Rolling Frame Assembly, Canilever Cage Option, XL-19CW & XL-24C

ITEM	PART	DESCRIPTION	QTY.
8-15	61922-000-00	ROLLING FRAME ASSEMBLY, Cantilever Cage Option, XL-19CW & XL-24C (See Figure 8-11 for NHA)	REF
-1	61924-000-00	.ROLLING FRAME	1
-2	00173-000-00	.BEARING	6
-3	11735-020-00	.PIN, Roll	1
-4	61359-000-00	.SPROCKET	1
-5	06452-000-00	.BEARING, Thrust	4
-6	61340-000-00	.SPACER	1

ITEM	PART	DESCRIPTION	QTY.
-7	61927-000-00	.SHAFT WELDMENT	1
-8	61310-000-00	.SHAFT WELDMENT	2
-9	11764-012-00	.RING, Retaining	2
-10	11252-008-00	.SCREW, HHC 1/4-20 UNC GR5 x 1	2
-11	11240-004-00	.WASHER, Flat 1/4 DIA.	4
-12	11248-004-00	.LOCKNUT, HEX 1/4-20 UNC	2
-13	61304-000-00	.PIN WELDMENT	2
-14	61336-000-00	.ROLLER	2
-15	27931-010-00	.BEARING	2

UpRight

UpRight, Inc.
1775 Park Street
Selma, California 93662
TEL: 209/896-5150
FAX: 209/896-9012

Canada
108 Industrial Drive
Whitby, Ontario, Canada L1N5Z8
TEL: 416/668-7701

Call Toll Free

1-800-926-LIFT

P/N 61799-001-00